

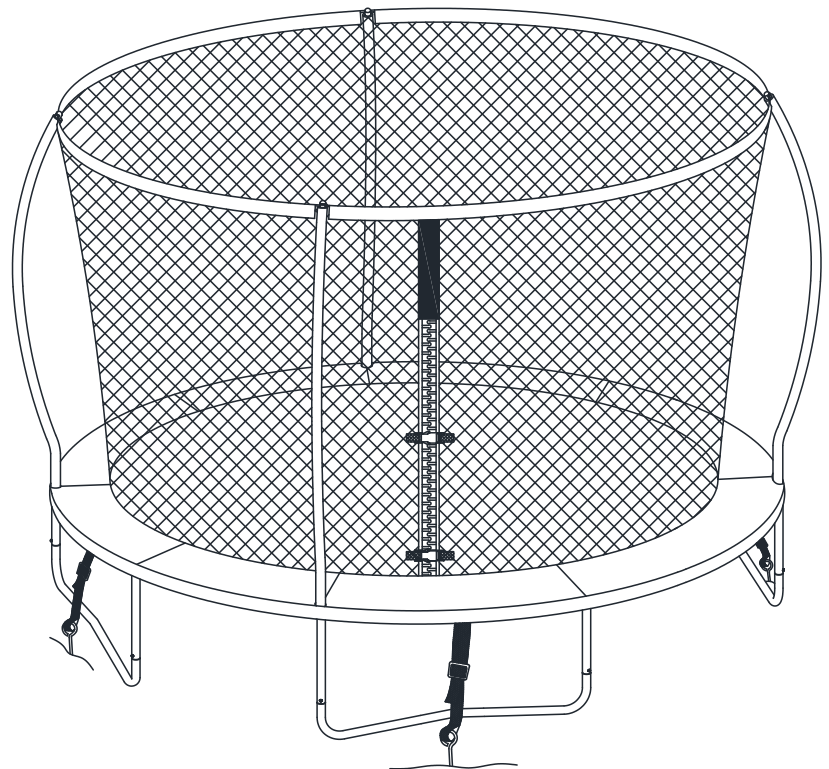

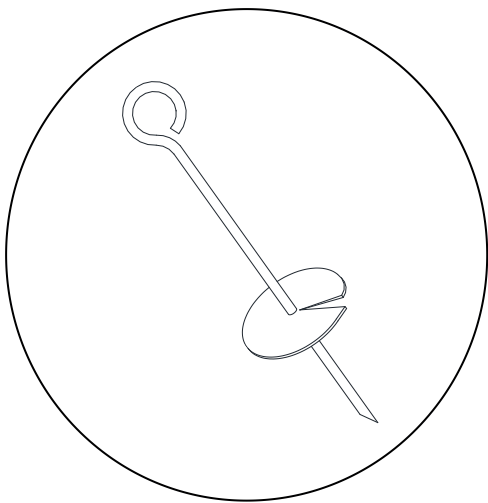

## TRAMPOLINE TIE DOWN KIT USER MANUAL



### **WARNING**

- THIS KIT IS DESIGNED TO HELP SECURE YOUR TRAMPOLINE DURING WINDY CONDITIONS. HOWEVER, IF EXTREME CONDITIONS ARE FORECAST, WE WOULD STILL RECOMMEND MOVING YOUR TRAMPOLINE TO A SHELTERED AREA OR DISASSEMBLING.
- ANCHORS WILL PROTRUDE OUT OF THE GROUND; AS SUCH THIS KIT MUST NOT BE USED ON A TRAMPOLINE WITHOUT A SAFETY ENCLOSURE FITTED AS FALLING OFF THE TRAMPOLINE ONTO AN ANCHOR COULD RESULT IN SERIOUS INJURY.
- WHILST THE STRAPS ON THIS TIE DOWN KIT HAVE BEEN TESTED TO A LOAD STRAIN OF 150KG ZERO GRAVITY CANNOT FORSEE SOIL AND WEATHER CONDITIONS THAT CAN AFFECT THEIR PERFORMANCE. ZERO GRAVITY DOES NOT STATE, GRANT OR IMPLY ANY GUARANTEES AS TO THE PERFORMANCE OF THIS TIE DOWN KIT.

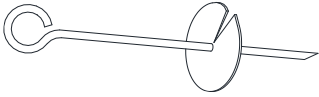
## Parts List

Part Number	Diagram	Description	Quantity
TD1A		Anchors	4
TD2		Hasp & Strap	4

## Step 1 - Where to use?

**⚠ ENSURE NO UNDERGROUND UTILITIES SUCH AS WATERPIPES, ELECTRICITY CABLES ETC ARE PRESENT WHERE YOU INTEND TO FIT THE ANCHORS.**

- Using a long screw driver or a rod-shape tool, insert into the ground to a depth of about 10 inches (25cm) where you intend to place the anchors. If you hit a stone, retry in a new location.

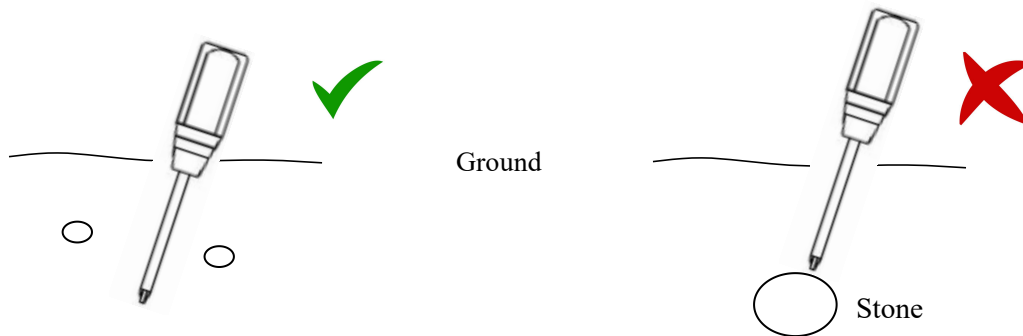

- Each anchor should be located approximately 6 inches away from the edge of the trampoline and should be evenly spread around the trampoline.

## Step 2 - How to anchor?

- Screw the anchor into the ground in a clockwise direction, using a strong screw driver or similar to provide extra leverage. Continue until only the eye of the anchor protrudes above the ground.
- The open end of the eye should be facing away from the trampoline.

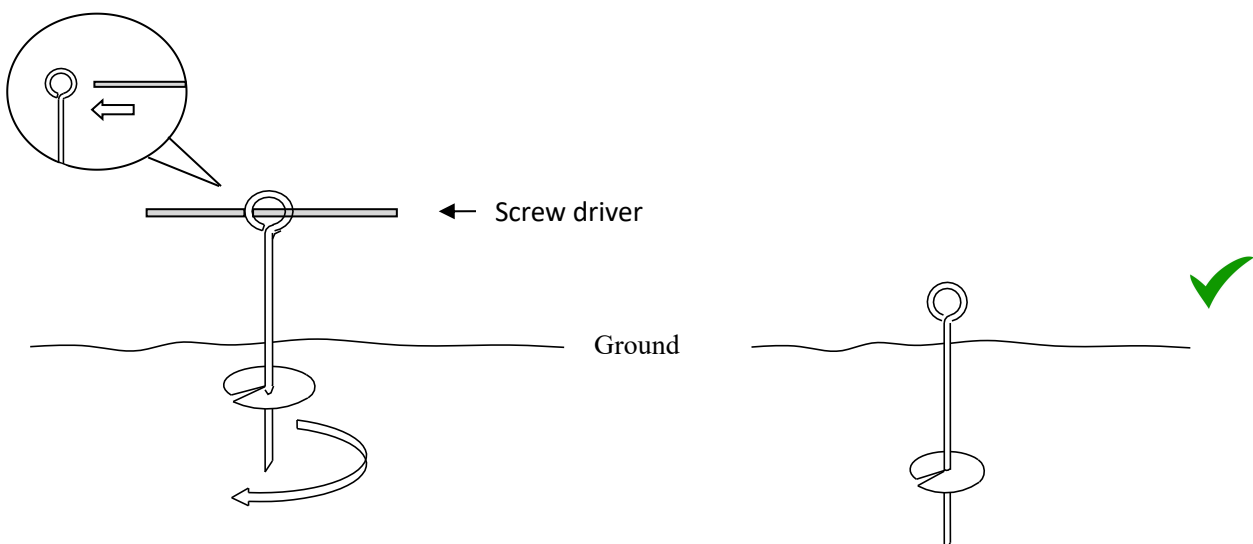

## Step 3

Follow the steps from 3-1 to 3-5.

**3-1 Connect loop onto the eye of the anchor.**

**Feed the strap under and then over the main frame of the trampoline.**

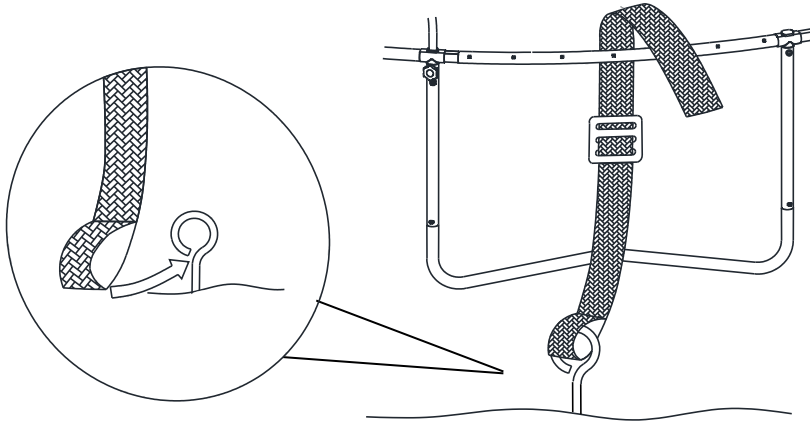

**3-2 Feed the end of the strap through the top slit in the buckle...**

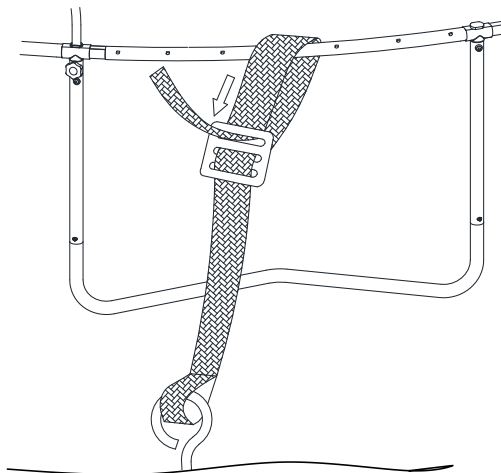

**3-3 ...and then through the bottom slit of the buckle.**

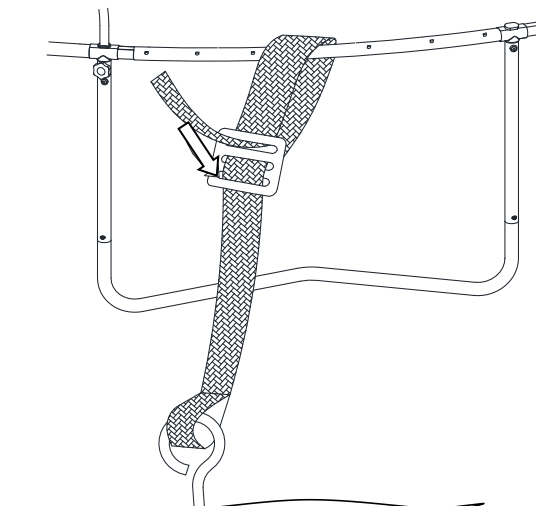

**3-4 Adjust the strap so that it is taut to complete installation.**

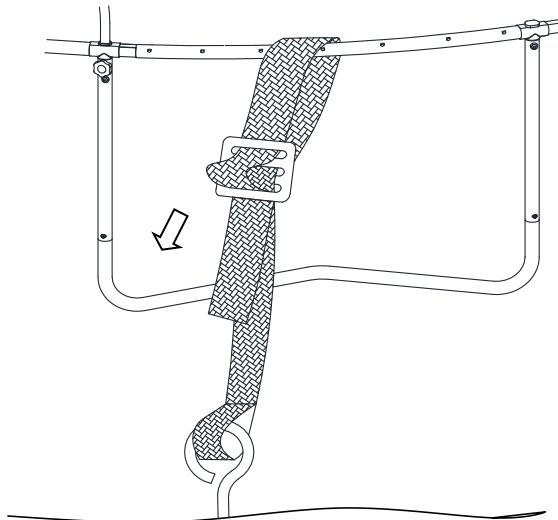

**3-5**

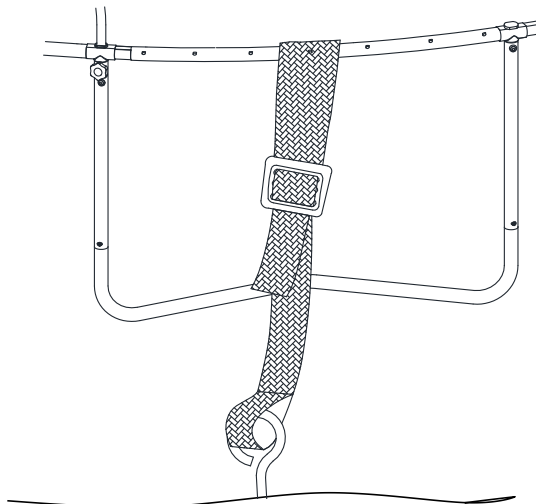

**HAVING PROBLEMS WITH INSTALLATION OR MISSING PARTS**

**THEN PLEASE CALL OUR CUSTOMER SERVICE TEAM ON**

**01264 771247**

**OR VISIT**

**[WWW.ZEROGRAVITYTRAMPOLINES.COM](http://WWW.ZEROGRAVITYTRAMPOLINES.COM)**