



USER GUIDE

WWW.MORETRACTION.COM

Copyright © 1999-2014 Davis Technologies, LLC.

All rights reserved.

Information in this document is subject to change without notice. Other products and companies referred to herein are trademarks or registered trademarks of their respective companies or mark holders. Any components shown are for illustration or instructional purposes only.

Publication and redistribution of this manual over the Internet or in any other medium without prior written content is expressly forbidden. In all cases this copyright notice must remain intact and unchanged.



Davis Technologies, LLC.

PO Box 8250

Asheville, NC. 28787

(828) 645-1505

E-mail: support@moretraction.com

Web: www.MORETRACTION.com

Trademarks

All trademarks used herein are the property of their respective owners.

Racepak® is a registered trademark of Competition Systems, Inc.

MSD® & Power Grid® are registered trademarks of Autotronic Controls Corporation.

Speedwire™ is a registered trademark of Speedwire Systems

V100215 10/15

Contents

Module 1: Introduction.....	1-1
1.0 How Does It Work?	1-2
1.0.1 Traction Control.....	1-2
1.0.2 Bump Box.....	1-3
1.0.3 Self-Learn Traction Control.....	1-3
1.0.4 Why You Should Purchase Self-Learning!.....	1-4
1.0.5 Pro-Axe	1-4
1.0.6 Programmable “Events” Functions.....	1-4
1.0.7 Self Diagnostics.....	1-5
Module 2: Installation.....	2-6
2.0 Profiler Kit Components	2-6
2.1 Software Installation	2-8
2.1.1 Important SD Card & License Information	2-13
2.2 COM Port Driver Installation	2-13
2.2.1 Windows XP	2-14
2.2.2 Windows Vista & Windows 7	2-14
2.2.3 Windows 8 and 8.1	2-14
2.2.4 Updating to Latest Firmware.....	2-14
2.2.5 Profiler Default File Structure.....	2-15
2.3 Profiler Front Panel	2-17
2.3.1 Overview.....	2-17

2.3.2 Bottom of Profiler Case	2-18
2.4 Hardware Installation.....	2-20
2.5 Wiring.....	2-21
2.5.1 Driveshaft Sensor.....	2-21
2.5.2 Davis Sensor Ring/Sensor Installation Notes.....	2-22
2.5.3 Installation to Racepak V300	2-24
2.5.4 Installation to Racepak V300SD.....	2-24
2.5.5 8 Magnet vs 4 Magnet Caveats	2-24
2.5.6 Pin Extractor Tools.....	2-24
2.5.7 In-Car Wiring.....	2-27
2.5.8 Profiler Basic Wiring Diagrams	2-29
2.5.9 Other Wiring Installation Notes.....	2-33
2.5.10 Plug Wiring Pin-Out Tables.....	2-34
Module 3: Initial Testing & Setup	3-1
3.0 Touch Screen Menu Trees.....	3-3
3.1 Diagnostics – Test First.....	3-3
3.2 Test Outputs.....	3-4
3.3 Stationary Test	3-4
3.4 Your First Profiler Run(s)	3-5
Module 4: Profiler Editor	4-1
4.0 UI Navigation.....	4-1
4.0.1 Main Tool Bar	4-2
4.0.2 Maximizing Screen Windows.....	4-16

4.0.3 Timing Window.....	4-17
4.0.4 Control Tab	4-21
4.0.5 Settings Tab	4-27
4.0.6 Events	4-35
4.0.7 Help Tab.....	4-43
4.0.8 Davis Technologies Support	4-44
4.1 Exporting Logger Data	4-45
4.1.1 Importing Driveshaft Files	4-47
4.1.2 Building a Profile.....	4-49
4.2 Timing Relationships	4-56

Module 5: Profiler Tips5-1

Appendix 1 License & SD Card Information 1

Appendix 2 Windows XP COM Driver Install 3

Appendix 3 Windows 7 COM Driver Install 7

Appendix 4 Windows 8 COM Port Install13

Appendix 5 Windows 8.1 COM Port Install18

Appendix 6 Integration With Racepak V30025

Appendix 7 Integration With Racepak V300SD27

Appendix 8 Touch Screen Menu Trees.....28

Appendix 9 Events Setup & Examples44

Appendix 10 Installing Bump Box & Trans-Brake.....49

Appendix 11 Speedwire Systems™ Integration.....51

Appendix 12 Disclaimer54

Contact Information.....56

Module 1: Introduction

We would first like to thank you for your purchase of our product. We believe it is the best system available to you on the market today. This revolutionary system balances effectiveness with ease of installation, broad field of uses, and cost.

As with all technical devices such as engines, shocks, carburetors, clutches etc., **the product's performance is based largely on your ability to use it properly.** Testing in controlled circumstances will help you determine the proper settings for your application and your situation. Testing is very important since it will help you utilize this product to its full potential.

Please carefully read all of the instructions and information thoroughly before attempting to install or use this product.

FOR RACING PURPOSES and OFF ROAD USE ONLY!

1.0 How Does It Work?

The Davis Technologies **Profiler** is a revolutionary multi-functional platform that combines multiple products in one compact, lightweight enclosure. By design, the enclosure is identical in size to the MSD 7730 Grid ignition controller so can be conveniently mounted on top of the Grid module with the supplied hardware, 4 2½" 6/32 stainless screws and spacers.

Currently the available Profiler modules are:

- Traction Control
- Bump Box
- Self-Learn TC
- ProAxe
- Events (programmable voltage outputs)

The Profiler was engineered to be the base platform for multiple option modules as well as new one's in the future.

This product differs somewhat from the other Davis Technology products in that the **traction control** portion of the Profiler uses a Windows PC based user interface for programming and transferring files to and from the user's computer to the Profiler through a standard USB connection or wireless Bluetooth connection to upload and download driveshaft curves. It is accurate to 1 RPM and samples driveshaft revolutions at 1000 per second! In addition it has the capability to **add** timing as well as take it away.

The built in licensed modules are currently accessed through the Profiler color touch-screen interface or the PC based software.

1.0.1 Traction Control

If you are familiar with some of the other Davis Technology traction control devices, the Profiler applies the newest technology that gives you features and functions that no other product currently on the market can provide. You now have the "baddest of the bad". With

the easy to use Windows interface, you will be able to import driveshaft log files from data loggers and use them as a baseline to program new curves (profiles) that have engine timing properties associated with them. The Profiler will use these curves and compare them with live driveshaft RPM data to **Retard** or **Advance** timing as the car goes down the track. This is unique in the traditional world of traction control. The Profiler samples the driveshaft data and analyzes it every 1/1000th of a second! Being able to react so quickly means it only has to make small corrections in timing to keep the driveshaft speed under control.

You are able to create and store multiple “profiles” for different tracks or conditions, etc. Again, a significant feature of the Profiler is that it not only can take power away through engine retards or selectively dropped cylinders, but can also add power by advancing timing as required.

1.0.2 Bump Box

The Profiler includes another module that was previously only available in a separate stand-alone Davis Technologies product, the Bump Box. It has now been incorporated into the Profiler and accessed through the built in touch-screen. The Bump Box function is the only device of its kind on the market today. By controlling the trans-brake with a high speed micro-processor, the car can be bumped into the beams with precision and control. This will allow you to focus on the tree, not worry about rolling the beams. This is NOT just for turbo cars, it works well for naturally aspirated and other power adders as well. See the videos on the Davis web site at www.moretraction.com.

1.0.3 Self-Learn Traction Control

Up until now, Self Learn Traction Control was only available in the Drag-Pro series of products from Davis Technologies.

By monitoring the average rate of acceleration of the drive shaft, and reacting to any sudden increases in that rate. The Profiler will automatically adjust to changing conditions, keeping the internal settings at optimal levels. The user can adjust the overall sensitivity of unit to achieve the desired results.

The Profiler is designed for the pro level racer who wants the most advanced Self-Learning technology, combined with enhanced adjustability and multi stage corrections to cut power more precisely than a single stage unit.

These units are perfect for racers looking for the unmatched precision of our Self-Learning units to get more aggressive with their tune ups, utilizing all of the adjustability that the Profiler has to offer.

1.0.4 Why You Should Purchase Self-Learning!

You may be asking yourself why you should want this option. The Profiler gives you the flexibility to program driveshaft RPM and time based profiles along with associated Zones with timing correction parameters. Once a run has started, if for any reason you pedal the car, it disrupts the time cycle so now your pre-programmed profile is not going to be accurate. The big advantage of using the Self Learning Traction Control is that it responds dynamically as described above, so you still have a layer of wheel speed management working all the way down the track whether you pedal or not. Again, this is because it works independently from time, only driveshaft speed, and not influenced by time parameters.

1.0.5 Pro-Axe

The Pro-Axe module is a built in delay box. It is completely digital, simple to adjust, and has .001 second accuracy. Being as it's now incorporated into the Profiler system, it has solid state reliability. It can be triggered on positive or negative signal.

1.0.6 Programmable “Events” Functions

Built into the Profiler platform is a robust set of programmable logic based, outputs than can be used for a multitude of race car functions.

- 4 – 30A solid state outputs
- 4 - 750mA solid state outputs

Examples of typical applications might be: Control an electric or air shifter, shift light, blower fuel lean-out, turn on water injection,

converter charge pressure solenoids, etc. The high power outputs can be pulsed (adjustable duty cycle), so could be used for controlling and progressing a nitrous kit, or any other solenoid based application.

The **Button** and **TPS** event trigger options provide a deeper level of flexibility and power to the Profiler platform. You can now have one button control multiple functions depending upon the programmed logic you enter. Bump in the beams with the button and use the same button after launch to short shift the car, turn on a nitrous kit, energize a converter charge pressure solenoid, or any number of other options.

The TPS (throttle position) options can be used to control how activated events react based upon if the car is pedaled during the pass, i.e. do they start over, resume from the point the car was pedaled, etc.

1.0.7 Self Diagnostics

The Profiler also contains a robust, easy to use, set of self-diagnostic tools to check if everything is as it should be. These are a huge aid in configuring and testing the system before getting on the track.

Test Outputs

- High Power circuits including Trans-Brake
- Low Power circuits
- Timing
- SmartDrop™

Test Inputs

- Trans-Brake
- Arm/Aux
- Driveshaft Sensor

Stationary Test

Module 2: Installation

Installation of the Profiler is straight forward but it's extremely important to do it correctly the first time! Improper installation could result in poor system performance or damage to the system.

Keep all wires away from any spark plug wires, coils, or other sources of electrical noise and heat.

2.0 Profiler Kit Components

The Profiler is shipped with several packages of hardware, pin extractor tools, wiring etc.



You should have:

- Profiler module
- Wiring harnesses
- Various terminated loose wires
- Mounting hardware (mounts on top of Grid module)
- Special connector pin extractor tools (2)
- Extra pins (2 styles)
- Profiler software or download link
- SD memory card with your Profiler licensing information
- SD memory card reader adapter
- Wiring connector Pin-Out data sheets (2)
- USB cable for connecting to Profiler from PC
- Davis Technology decals



2.1 Software Installation

You will load the Profiler software on your Windows PC. Put the software files in a folder on your PC. To begin loading the software, double click the **Profiler_setup** icon .



Profiler_setup

If you get the warning message box asking “Do you want to allow the program from an unknown publisher to make changes to this computer?” Select **>Yes**

You should then see the following screen popup:

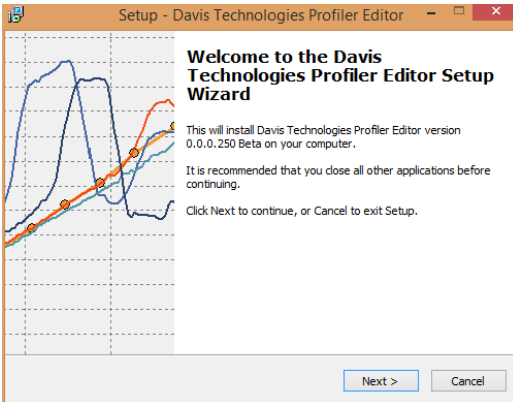

Select **>Next**

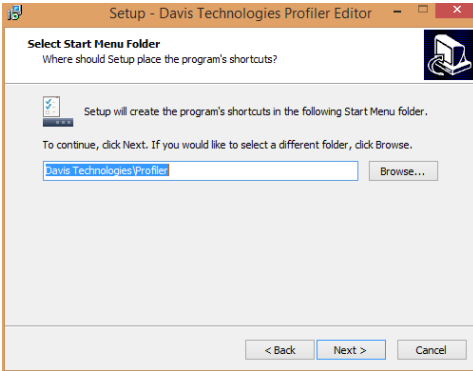

If you wish to load the software into a different folder than shown, browse to where you want install it. Otherwise Select **>Next**.

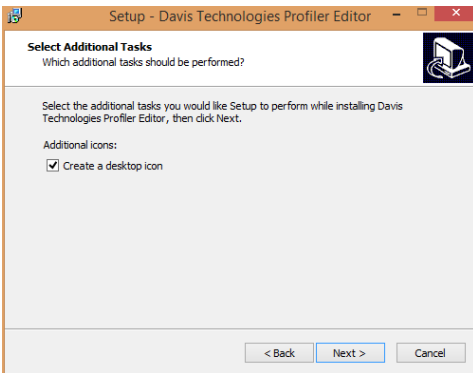

If you wish to have the Installer generate a Profiler desktop icon for you, check the box (recommended).

Select **>Next**.

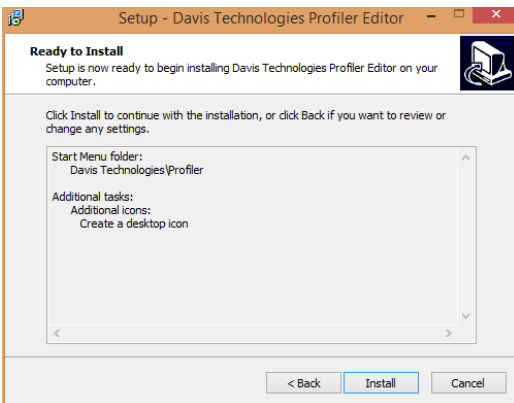

This is simply an installer summary screen of what software will now be loaded.

Select **>Install**.

After a few seconds, the following window appears:

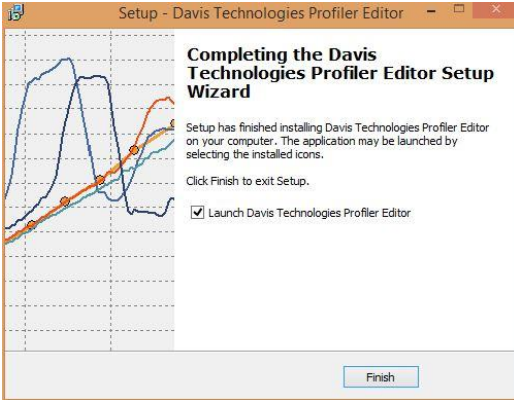

It is recommended to launch the Profiler software after the install is completed as you will be checking to ensure you have the latest software version.

Select **>Finish**. The Profiler Editor program with default Profile will launch.

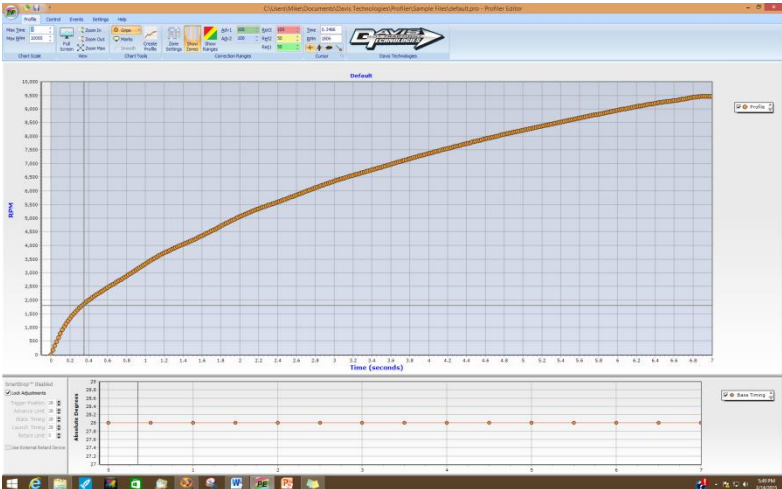

Congratulations, you have successfully loaded the Profiler software!

Next, ensure the latest version of Profiler software is loaded.

In the upper portion of the Profiler window you will see a menu bar section that looks like this:

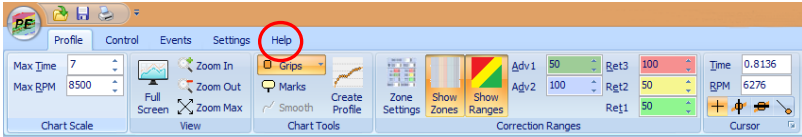

Select the “Help” tab.

NOTE: Ensure your PC has Internet access for this next step as the system will check the Davis Technologies website for any software updates that might be available.

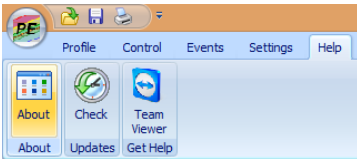

Select >Check Updates

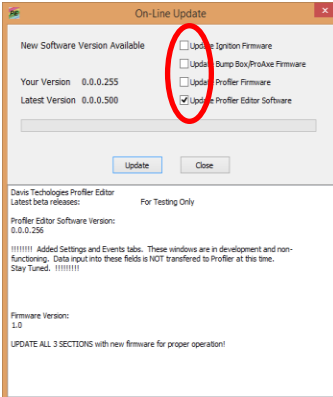

Once the system connects to the Davis Technologies server the following window will appear:

As you can see in this example, it indicates that there is a newer version of software available. It shows the current version level as well as the newer level.

Since you are NOT connected to the Profiler module yet, you will only be updating the **Profiler Editor** Software.

For now, **uncheck** all the boxes **except** the bottom one shown above.

Select >Update

Once the new software was downloaded you will see the following window:

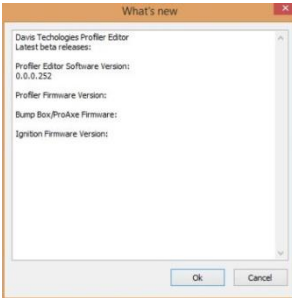

Select >OK

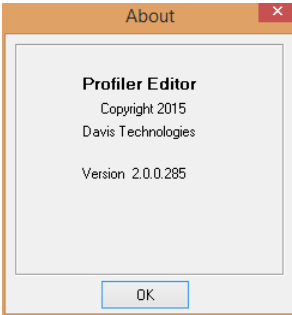

Select >OK.

Once the new version is loaded and launches the Profiler Editor application, software installation is complete!

You will return after the hardware installation and ensure the firmware in the Profiler is the latest version. It will be basically the same process only you will be checking the option boxes you unchecked during the software installation.

Note that you must be certain the Davis COM Port driver is loaded and working in order to download firmware as well as be able to

upload and download files to the Profiler. See **Section 2.2** on how to check if the driver has installed successfully.

NOTE: After updating the firmware, you must always reset the box or power it Off and On again

2.1.1 Important SD Card & License Information

Your Profiler license information resides on the SD card. The licensing is an encrypted file stored on a specifically formatted card that is all locked to your Profiler box. If you try to use another SD card and copy your license file to it, it's not going to work on your Profiler or anyone else's.

NOTE: *If any of the Profiler touch screen buttons are black, that indicates the function is disabled because it has not been licensed.*

Click >**Appendix 1** if:

- Lost or damaged your SD Card
- Accidentally erased your license file
- Left your USB cable at home or damaged it
- Damaged the Micro USB port on the Profiler
- Can't get normal file transfer to work

2.2 COM Port Driver Installation

Successful installation of the USB COM Port driver is critical to using the Profiler. The only way to transfer files in and out the Profiler are via the USB port or by Bluetooth.

Davis Technologies has validated the USB COM Port driver with Windows Vista, Windows 7, and Windows 8 & 8.1. Please see the appropriate Operating System section below to install and verify installation.

2.2.1 Windows XP

If you are running Windows XP Click >**Appendix 2**

2.2.2 Windows Vista & Windows 7

If you are running Windows 7

Click >**Appendix 3**

2.2.3 Windows 8 and 8.1

Important NOTE: As of 6/2015 the Davis COM port driver is certified as a Windows compliant signed driver so should automatically install without any problems.

If for some reason you run into an issue, follow the procedure links outlined below. These will take you through step by step to disable the driver signing checks in Windows if need be. Again, with the latest software you should *not* have to perform the process.

If you are using **Windows 8** Click >**Appendix 4**

If you are using **Windows 8.1** Click >**Appendix 5**

2.2.4 Updating to Latest Firmware

Once you have the COM port working and your PC is communicating with the Profiler, you can do the On-Line Update checking the Firmware options. In most cases your Profiler is shipped with the latest firmware already loaded. As updates are released, you will use this tool to download and update your firmware.

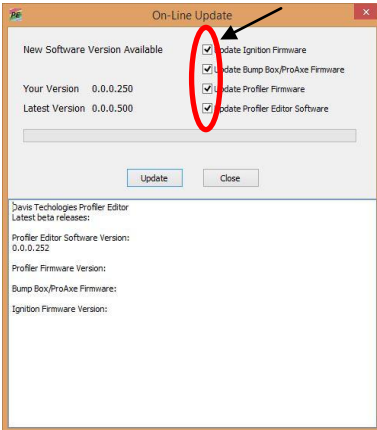

Once the update is complete the Profiler application will open. At this point the main software suite is loaded and functional. Next, you will need to know where the various file folders have been installed on your computer.

During the installation, the system installed a Profiler icon on your desktop for launching the application.





Profiler Editor desktop icon.

2.2.5 Profiler Default File Structure

It is important to understand how the Profiler software structures the folders where the various types of files will be stored on your PC.

During the software installation, the default location for the Profiler folder is C:\Users*UserName*\Documents\Davis Technologies (*unless you changed the default installation directory*)

Within the directory you will see some 2 sub-folders



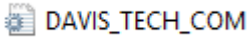

-  Drivers
-  Profiler

Within the Drivers folder is the Profiler Com port driver



In the “Library” folder there is a set of sub-folders

Name

-  BaseTiming
-  Corrections
-  Profiles
-  Runs
-  Zones

There may be a **Sample Files** folder that has a “default” profile stored there. Later if you wish to keep some sample profiles to practice with etc. this would be a good place to store them.

Once you begin to use the software to create data files, each file type will be stored in the associated folder for easy access through the Profiler user interface. At this point the file folders will be empty. *What’s important to remember is the location of the folders on your computer so you can find them once you begin using the system.*

2.3 Profiler Front Panel

The Profiler product has built in touch screen and user interface. Several previous standalone modules have been combined into the product and are accessible through the touch screen on the front of the unit. Additional controls are available here as well helping eliminate connecting to a PC to perform some common functions such as turning traction control On/Off as well as other functions.



2.3.1 Overview

Indicator LED's

Status - The status lamp indicates power is on.

Arm – The Arm lamp indicates that the Arm switch was activated. (External switch to be wired in)

Launch – The Launch lamp indicates a run has begun. (Release of the trans-brake)

Bluetooth – Indicates an active Bluetooth connection. Blue LED will blink if box is configured to use a Bluetooth connection and will glow steady when a connection is established.

Touch Screen UI

The Profiler has a built in touch screen interface that provides convenient functionality without having to connect to a PC device.

As mentioned in a previous section, if any of the touch screen buttons are black, it indicates that function is disabled because it must be licensed.

2.3.2 Bottom of Profiler Case

26 Pin Main Harness 6 Pin High Power SD Card Micro-USB

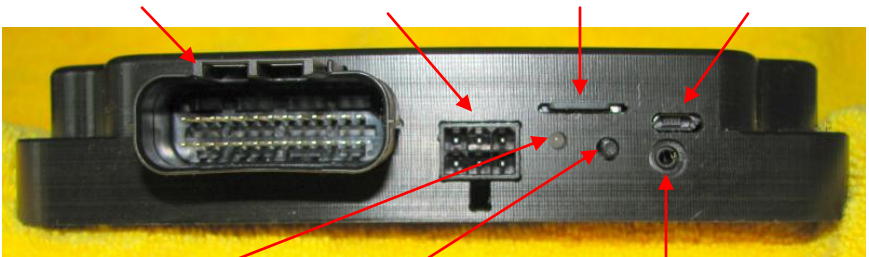

Crank
Trigger Pulse LED Reset Button Remote Touch Screen Port

LED

On the bottom of the Profiler case there is a recessed LED that will blink every crank trigger pulse. (good diagnostic tool)

SD Card

The Profiler uses a common SD memory card for data & license information storage. Without this card inserted, your Profiler will only function for a limited time. The card can store up to six “Profiles” that are accessed using the touch-screen menus.

USB Port

A standard Micro-USB port is used for connecting a PC to the Profiler for the purpose of firmware updates and file upload/download functions. The USB cable is supplied with the kit.

Reset Button

There is a Reset button on the bottom of the unit. **Use this to escape out of “Test Mode”** after running a test.

Remote Screen Port

A 1/8” jack port is for plugging in a remote touch screen so a driver or crew member can easily and quickly change to a different stored profile while in the staging lanes.



2.4 Hardware Installation

Before beginning installation of the hardware and wiring, ensure you have everything required. Whatever you need should be packaged in the kit except for the basic wiring tools.

Mounting

Before mounting the Profiler, its a good idea after loading the Profiler PC software to use the USB supplied cable to connect your PC to the Profiler box. When you do this, the Profiler will be powered up and the splash screen becomes active.



Before units are shipped, each one is configured with the licensed customer's name. When powered up the Profiler will display your name in the upper left corner of the screen. When a Profile file has been loaded, the name of the file that is currently loaded is displayed, a very nice feature. (your unit may indicate a test Profile has been loaded prior to shipping)

If everything appears to be working, go ahead and mount the box. You will be doing some installation setup, so wherever you mount it, be sure you can clearly see and access the screen. Sometimes it's easier to mount it permanently **after** the main configuration is completed.

If you have a MSD Grid system in your car, the kit comes with 4 phenolic spacers and 4 2½” stainless screws. Use the hardware kit to install the Profiler on top of the Grid controller as shown.



2.5 Wiring

Depending upon what kind of power adder and ignition system you are using will dictate what the installation wiring is.

The Profiler kit includes a wiring **Pin-Out data sheet** to use for reference. It's also located in Section **2.5.10** of this guide.

2.5.1 Driveshaft Sensor

A standard 8 magnet driveshaft collar and Hall Effect sensor will work in most cases with the Profiler, however for the ultimate resolution; it is recommended that a sensor from Davis Technologies be installed. The Davis sensor assembly uses a same or similar mounting location; however the collar ring contains machined steel teeth that are picked up by the Davis sensor which is far more

accurate than using a magnetic field type sensor. If you have questions, call Davis Technologies for help.

We know that the sensor is going to trigger on the machined edge, not here versus there because one magnet is stronger than the other.

NOTE: There are other driveshaft sensors and data logger inputs so you may need to follow some of the alternative installation notes that follow.

The Davis sensors have multiple outputs so that one ring sensor can trigger three or four things, be it the Davis box, the engine management system, a Racepak and other systems. One sensor can trigger them all.

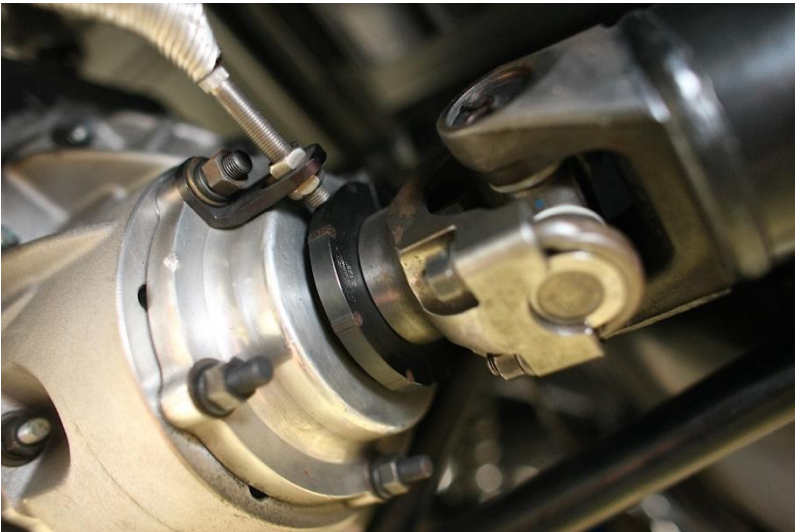

2.5.2 Davis Sensor Ring/Sensor Installation Notes

It is crucial that the driveshaft sensor ring be installed correctly.

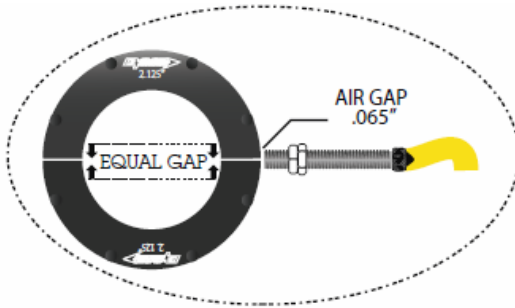

Take care to insure the gap is equal where the two halves meet as it can affect accuracy. **DO NOT over tighten the sensor jam nuts!**

DS Sensor Wiring

The driveshaft sensor should be wired as shown below.

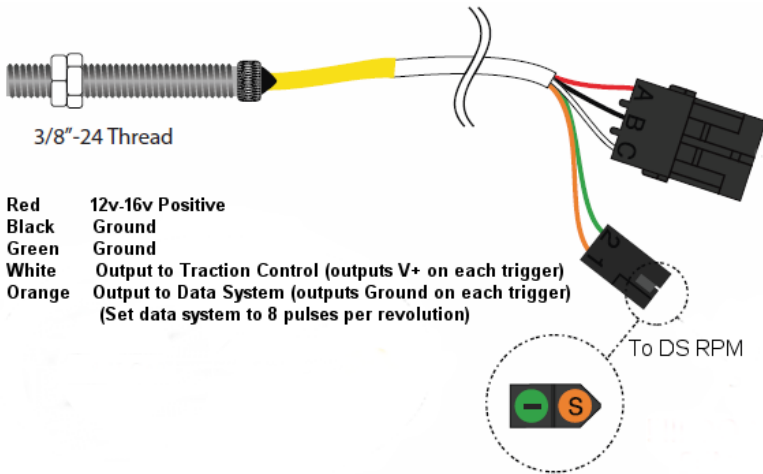

For other vendor collars and sensors, follow their installation instructions. Integration to data loggers may vary slightly as discussed below.

Use an 8 magnet collar to ensure good data resolution and accuracy.

2.5.3 Installation to Racepak V300

If you are integrating with a Racepak V300

Click >**Appendix 6**

2.5.4 Installation to Racepak V300SD

If you are integrating with a Racepak V300SD

Click >**Appendix 7**

2.5.5 8 Magnet vs 4 Magnet Caveats

Some data logging systems will accept up to 8 pulses per revolution and some only allow 4 pulses maximum. In most cases, 'Follows Input' will work unless your logger or EFI system requires something specific.

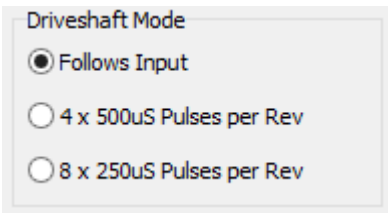

2.5.6 Pin Extractor Tools

You may need to extract or add wire/pins from time to time so you will need the pin extractor tools that are **included** in the kit. There are two tools, one that is flat and straight, and one that has an end that looks like a pair of tweezers. The straight tool is used for the big 26 pin plug and the other is used on the small 6 pin connector that has the 16 Gauge wires for powering and switching external components.

Using the Large Plug Pin Extractor

First you will need to remove the orange plastic end of the connector. Using the flat extractor tool with the two “fangs” facing towards the connector, you will want to position them so they are **inside** the little tabs on each end of the orange piece.



Gently push the tabs towards the ends (outwards) to release them and lift the orange piece upward.

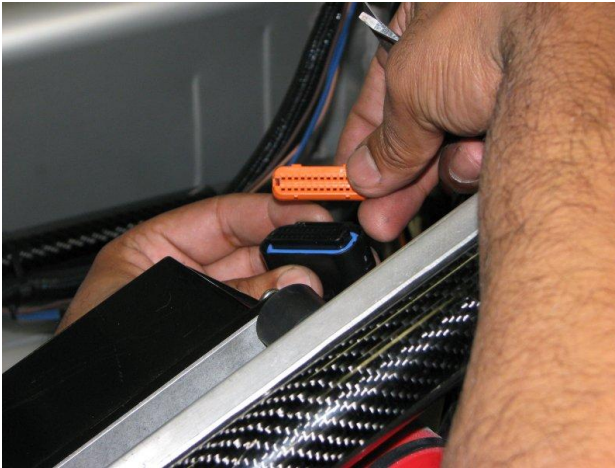

Once you remove the orange end piece, the end of the connector will look like the picture below. Use either end of the tool to extract pins as shown.

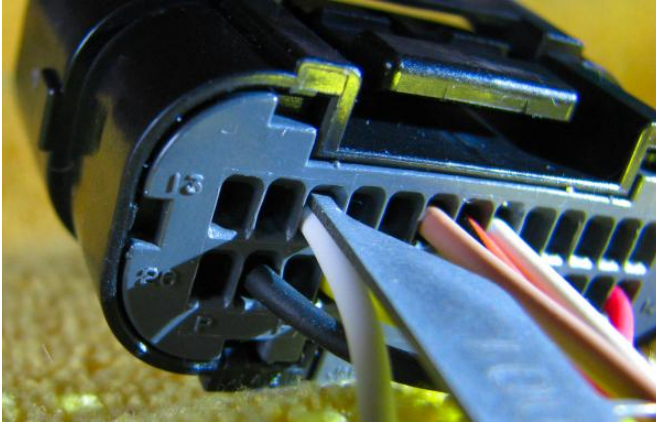

Orient the plug as shown so the pin number markings are right side up. Stick one of the pointed ends of the tool into the wire end hole that corresponds to the pin you wish to remove (on top of the wire as shown). While holding the wire, gently pull it out a little, and then remove the tool before pulling the wire/pin all the way out.

Install any other wires as required for your applications and replace the orange cap on the pin end of the plug by pushing it back on.

Using the Small Plug Pin Extractor

The smaller 6 pin plug takes a different pin extractor tool, the one that has a “tweezers” like end is included in the kit.



The pins in this plug have two locking tabs.



To release the pin in the plug, slide the tool down each side of the pin as shown below to release the tabs and gently pull the wire/pin out from the back side of the connector.

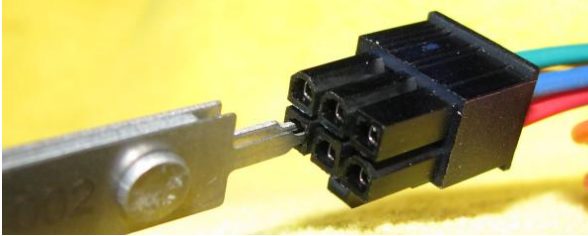

To re-install, push the wire/pin into the connector from the other end.

2.5.7 In-Car Wiring

Next you will install the (harness shown is for a MSD Grid) ignition controller. This harness goes between the ignition box controller and the ignition in the case of a MSD Grid and 7720 system. A car using a magneto can be hooked directly to pins 12 and 13 per the connector pin-out sheet. **When you ordered the Profiler you should be supplied with the correct harness assembly for your application.**

The big Profiler plug will have both **Yellow** and **White** wires terminated with plugs to match up with the **Yellow** and **White** wires in this harness, plug them together.

The **Black** and **Red** terminated wires are for the Profiler power. Plug it into the Profiler Red/Black wires that have a matching plug on the end.

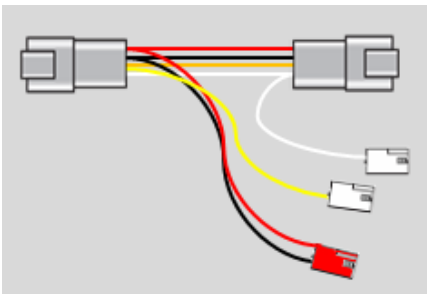

Davis supplied Ignition Harness.

Run a white wire (Driveshaft Sensor Signal) to the rear of the car where you installed the DS sensor “Y” harness.

Run the **Tan** wire to a switch that will arm the Profiler just prior to staging the car. You can install one in the car or put one on the rear of the car if you have someone turn on your data logger already. Any small toggle type switch will work.

NOTE: A momentary switch will NOT work. If you already have some type of “arming” switch such as for nitrous installations, you can simply tie into that instead of using a separate switch.

See the next section for detailed wiring instructions. The basic wiring is quite straight forward. Wiring for various other components and connectivity is also located in the next section.

2.5.8 Profiler Basic Wiring Diagrams

The following diagrams illustrate the Profiler basic wiring. For more options refer to the option tables below and the pin out tables in Section 2.5.10.

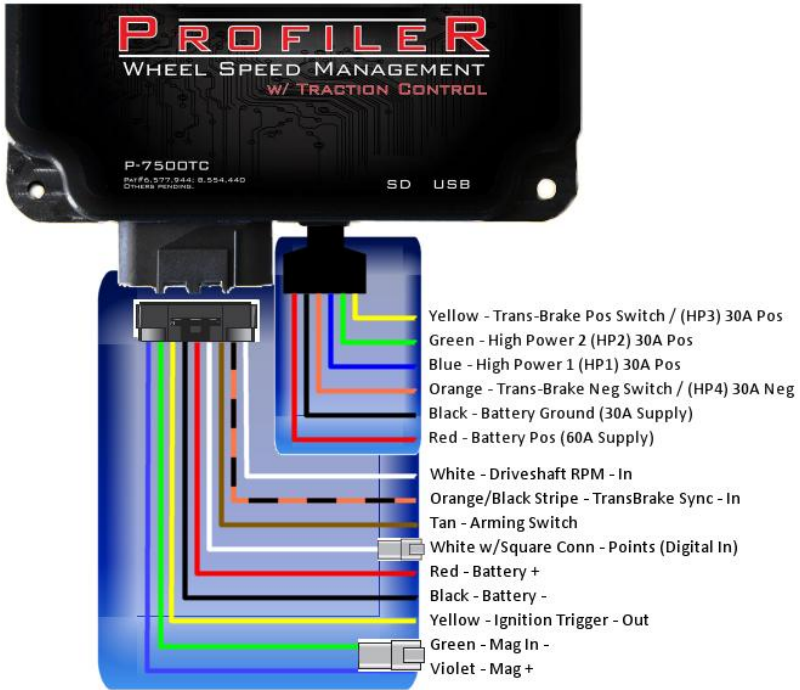

If you are going to use the Profiler for any of the following functions add these wires to the plug. These are suggestions to consider.

Function	Color Wire	Pin
Trans-Brake	Orange/Black Stripe	7
Bump Box Trigger	Pink	10
Magneto -	Green	12
Magneto +	Violet	13

Tach – Timing Out 750mA Neg (LP6)	Gray	18
DS RPM Out 750mA Neg (LP5)	Orange	19
Launch Sync Trigger Out 750mA Pos or Neg	Blue Active only if Profiler is armed & TB ON	20
Shifter Control (HP1 or HP2) 30A Pos	Blue or Green	1 or 2
Fuel Lean Out (HP1 or HP2) 30A Pos	Blue or Green	1 or 2
Water Injection (HP1 or HP2)30A Pos	Blue or Green	1 or 2
Converter Charge Press Solenoid (HP1 or HP2)30A Pos	Blue or Green	1 or 2
Trans-Brake Pos (HP3) 30A Pos	Yellow (16ga)	3
Battery Pos 60A Supply	Red (14ga)	4
Battery Ground 30A Supply	Black (14ga)	5
Trans-Brake Neg (HP4) 30A Neg	Orange (16ga)	6
Racepak sensor to log Profiler timing corrections (See overview in this section)	Light Green	21

Option: Use Racepak to Log Profiler Timing Corrections



Even though the Profiler logs downloadable runs and timing corrections, you may wish to have the timing corrections included in your Racepak logs along with your other data. It's nice to see the corrections along with other data. If so, follow the directions below. This is an **option**, not a requirement.

It's a very straight forward solution and installation. You will need to purchase a Racepak part # **230-VM-5VDIFF 0-5V** Differential Input sensor. Wire this sensor to the Profiler pin 21 (Light Green wire) which is the analog timing correction output. This wire is NOT installed in the big plug but is loose in the wiring package included with the Profiler.

Install the new sensor per the Racepak installation instructions. Enter the following Linear Conversion parameters. Your actual values to enter will depend upon the range of degrees of Advance and Retard. In the example below, the Advance would be a maximum of 4 degrees and Retard a maximum of -10 degrees. Enter yours accordingly to match your Profiler timing settings.

Raw data value value A: **0** will become **4**

Raw data value B: **5** will become **-10**

Minimum result value: **-10** maximum **4**

Display **3** digits before decimal point **2** after

Smoothing you can leave at default of 1

Once you make a run with the Profiler Timing sensor in place, you will notice that when you open both the ProfilerTiming and EngineTiming Racepak channels, notice that they are independent of each other. Having both channels in the Racepak log makes it much easier to see how the two relate to each other during a run.

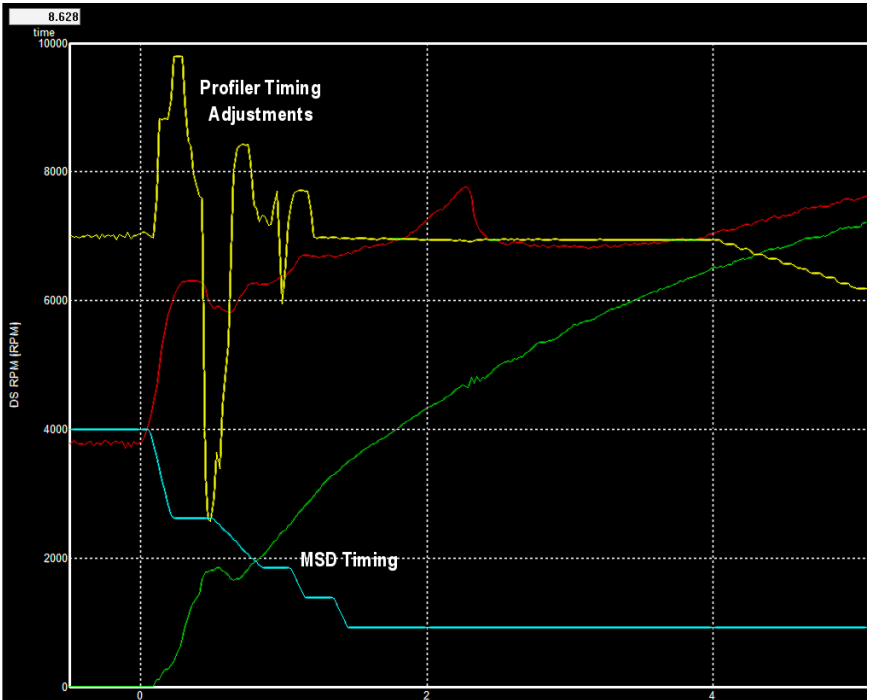

2.5.9 Other Wiring Installation Notes

Here are just a few examples of how you might use the Profiler to control multiple functions in your race car.

It is recommended you use the Profiler to control your Trans-Brake as there is an advantage. A typical relay controlled solenoid circuit has voltage surge as the magnetic field of the coils collapse which can cause a small delay. The Profiler uses solid state switching (no relays) that eliminates any delay which means your TB will deactivate faster.

In addition, once you have the Trans-Brake wired in, you have the option to use the **Pro-Axe** launch delay controller that is integrated into the Profiler. To use it, just Select **>Settings>ProAxe** in the top menu bar of the software and enter the amount of delay you wish to use. You can also access it through the touch screen menu by Touching **>Main>ProAxe** and entering the value.

HP1 and HP2 High Power circuits are positive (+) switched circuits however can also be pulsed if needed. This means you may well use them as a progressive nitrous kit controller or perhaps to progressively control a converter charge pressure solenoid as two examples.

There are 4 low power circuits that are all Neg (-) outputs rated at 750mA each and have thermal fuse protection. **You must turn the Profiler OFF, and then back ON to reset a tripped fuse.**

The High Power Events are very accurate, **1 RPM** for Driveshaft or Engine RPM triggers! If you want precise shift points for your automated shifter or any other device, use this!

It's easy to understand, the Profiler is far more than just a Wheel Speed Management device! It's a platform for many functions now as well as expanded in the future. Use your imagination and let it manage and automate functions for you to minimize wiring, without the need for additional modules. All that potential, automation, integration, and accuracy, is in a small 11oz box!

2.5.10 Plug Wiring Pin-Out Tables

Large connector

Pin	Color	Function
1**	White w/Blk Stripe	Drive Shaft RPM VR Sensor Input -
2**	Green	Drive Shaft RPM VR Sensor Input +
3**	Orange w/White Stripe	Analog Input
4**	Green w/White Stripe	Analog In for Pass Through
5	Pink w/Black Stripe	TPS Input
6	White	Drive Shaft RPM In
7	Orange w/Black Stripe	Trans Brake Synch In – (configured either + or -)
8	Tan	Arming Switch
9**	Yellow w/Black Stripe	Serial RX
10*	Pink	Bump Box Trigger Button
11	White w/Square Conn	Points (Digital In)
12	Green	Main In -
13	Violet	Main In +
14	Red	Battery Positive
15		Battery Positive
16*	Black w/White Stripe	Low Power Event 8 (LP8) 750mA -
17*	Brown w/White Stripe	Low Power Event 7 (LP7) 750mA -
18	Gray	Tach-Timing Output (LP6) 750mA -

19*	Orange	DS RPM Output (LP5) 750mA -
20*	Blue	Launch Sync Trigger Out 750mA (+ or -)
21*	Light Green	Correction Analog Out
22**	Yellow w/White Stripe	Serial TX
23	Yellow	Ignition Tripper Output
24		Battery Ground
25	Black	Battery Ground
26		Battery Ground

Small Connector (16Ga)

Pin	Color	Function
1	Blue (16Ga)	High Power 1 (HP1) 20A Pos (Unprotected)
2	Green (16Ga)	High Power 2 (HP2) 20A Pos (Unprotected)
3	Yellow (16Ga)	Trans-Brake Positive Switch/(HP3) 20 A Pos (Unprotected)
4	Red (14Ga)	Battery Pos (60 Amp Supply)
5	Black (14Ga)	Battery Ground (30 Amp Supply)
6	Orange (16Ga)	Trans-Brake Neg Sw/(HP4) 30A Neg (Unprotected)

* Included but not installed in connector

** Optional / Future use

Module 3: Initial Testing & Setup

You will now power the unit up by turning on your Ignition system.

You should see the screen light up along with the status LED's on the left side of the screen.



Installing Latest Firmware

You want to ensure the Profiler has the latest version of firmware. It should have the latest version when it was shipped to you but there will be updates later. You can check to see what firmware version you have by touching the flash screen at Power On. You will see the screen below.



If a function is enabled, the button is **Green**, if turned off, it will be **Red**, if the function is NOT licensed it will be **Black**.

If there is a Profile loaded its name will display as shown here.

Touch the **Main** button.



Touch the **Utilities** button.

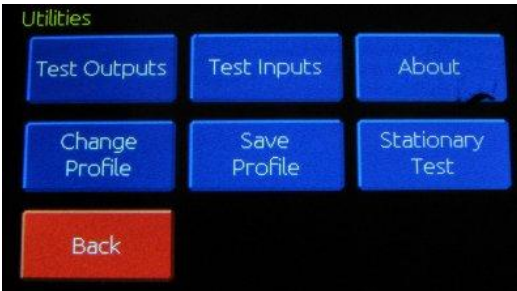

Touch the **About** button.

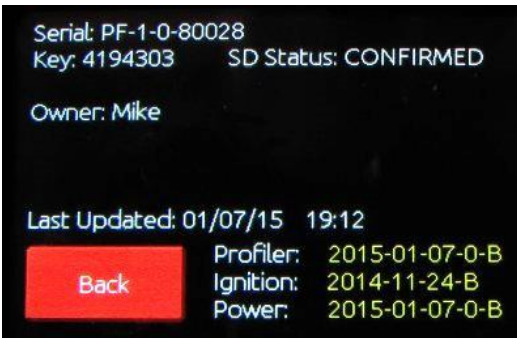

This screen shows the Profiler serial number, owner, last update date, and firmware version level.

3.0 Touch Screen Menu Trees

All of the Profiler touch screen menus are in an Appendix section at the back of the User Guide. You can use these as reference. Using the touch screen will get you familiar with navigating the menus and settings.

Click >**Appendix 8**

3.1 Diagnostics – Test First



Before you run the car you will want to verify the input and output circuits are functioning as expected **before** taking the car down the track!

The Profiler has a robust set of built in diagnostic tools to ensure everything is set and functioning correctly.

From the touch screen:

- Select >**Main**
- Select >**Utilities**
- Select >**Test Inputs**

There are 3 menu options:

- **Transbrake/Sync** – Activate the transbrake button and see if the white dot displays in the box.
- **Arm/Aux** – Turn the Arm switch on to verify the white dot displays in the box.
- **Driveshaft** – If the car is on jacks, turn the Profiler on, turn the Arm switch on, activate the transbrake and release it,

manually rotate the rear tires to see if the white dot indicator blinks On/Off as it picks up each sensor pulse.

Once you enter the Test Input utility, in order to resume operation, you must press the **Reset** button on the bottom edge of the case.

3.2 Test Outputs

From the touch screen:

- Select >**Main**
- Select >**Utilities**
- Select >**Test Outputs**

You will have menu options to test:

- HP - Touch whichever buttons you have something connected to the Output (HP1-HP4) to ensure it activates.
- LP – Touch whichever buttons you have something connected to the Output (LP5-LP8) to ensure it activates.
- Timing – Touch the button and you will see a self-test followed by returning to the menu.
- Smart Drop™ – Touch the button and you will see a self-test run through a sequence of cylinders (1-4). It will indicate the test is complete and return to the menu.

3.3 Stationary Test

The Stationary Test is used to cycle the Profiler through a simulated run using a loaded (active) Profile. If you want to see everything except timing corrections, run the car on jacks and simulate a run. Download the run after the test and you should see driveshaft RPM, timing, etc. as you would for a normal run. Check timing with a light to ensure what you see on the balancer matches your Static Timing setting.

Note that timing corrections are automatically **disabled** during this test and will be turned back on at the next power up.

After running all these tests, you should feel comfortable that everything is working normally.

3.4 Your First Profiler Run(s)

It is recommended you create a “Test” Profile that has timing corrections minimized in order to eliminate the possibility of engine damage as well as getting a good idea of how the Profiler is responding to your driveshaft curve (Profile).

Adjust Zone settings so advance and retards are at minimums of .25 or .5 degrees. The idea is to make a run, download the data and see where corrections are being made. You may find you have to adjust your Profile up or down in certain areas to minimize corrections. For instance, the track may just not take a given level of power or some places it may take more.

After a few runs you will see the Profiler showing you what and where it wants adjustments. In areas where it consistently advances timing you will want to move your Profile line up, in areas where it consistently retards timing, move the Profile down a little. Once you feel like you have it dialed in pretty well, go ahead and adjust your Advance and Retard Zone values to where you want them and let it eat!

Experience shows if you import some reasonably good driveshaft curves from your logger prior to the Profiler installation, it will only take 2-3 passes and you are well on your way to consistent, quick runs.

Module 4: Profiler Editor

Now that you have installed the Profiler hardware and software, this is where the fun begins! Let's tap into its potential and start going quicker and faster.

4.0 UI Navigation

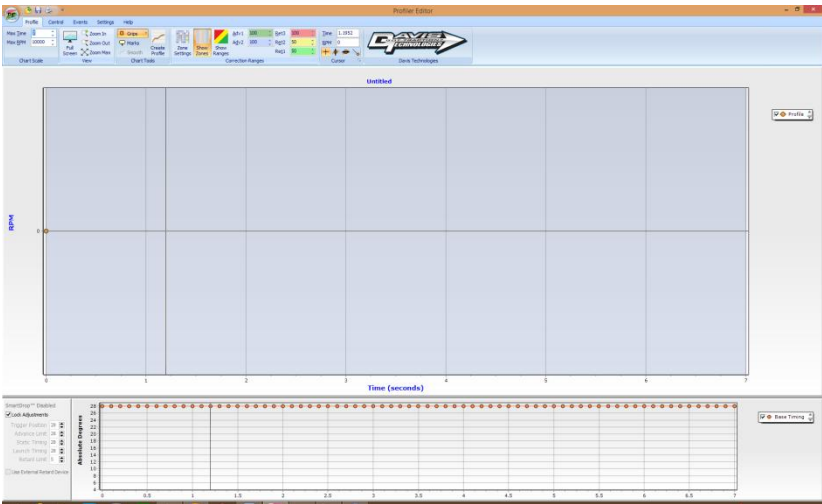

Open the program by selecting the Profiler Editor icon that was installed on your PC desktop. The program will launch and you see the main.

The main screen consists of three main sections:

- Main tool bar
- Plotting (Profile) section in the middle
- Timing section on the bottom

4.0.1 Main Tool Bar

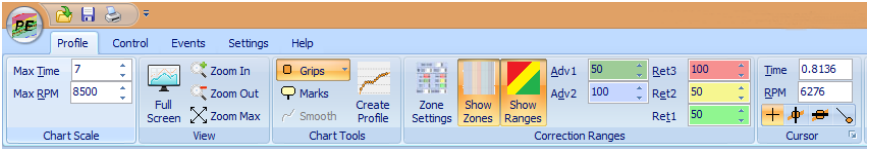

The **Profiler Editor** icon in the upper left corner of the screen provides access to several functions. Click on the icon to see what functions are available.

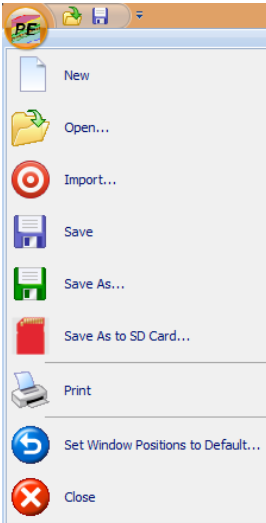

These options provide common functions most PC programs use.

- **New** to create a new Profile
- **Open** to open an existing Profile
- **Import** run data
- **Save** to save file
- **Save As** to save copy or rename
- **Save As to SD Card**
- **Print** to print the Profile screen

Note: To Save to SD card, it must be taken out of the Profiler and inserted into a SD card reader or the supplied adaptor. See **Appendix 1**



The file folder and disk icons perform the same basic function as other PC programs. Selecting the folder on the left opens a dialog box that allows you to name and store a Profile that you have created.

Selecting the disk icon allows you to store a Profile on a drive such as a thumb drive for example.

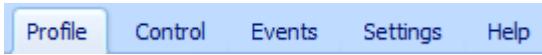

The top portion of the main tool bar contains a series of “Tabs”. When the Profiler Editor main screen opens it will default to the “Profile” tab as shown above. This displays the main tool bar.

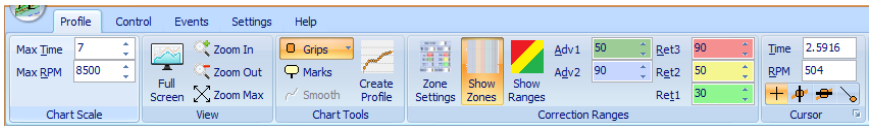

This main tool bar is separated into 5 sections

- Chart Scale
- View
- Chart Tools
- Correction Ranges
- Cursor

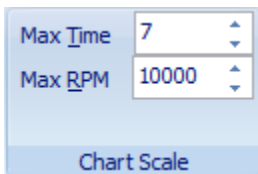
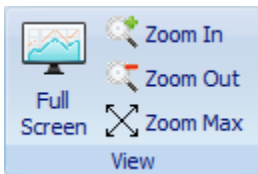

Chart Scale will be the basis of the plotting area scaling parameters for run length and driveshaft RPM. Set these parameters to match your car’s typical run data.



View lets you Zoom In and Zoom Out and will adjust the view to whichever section of the screen is selected. Selecting **Zoom Max** will return the view to it was before the zoom function was used.

Full Screen maximizes the view to the screen size of your monitor.

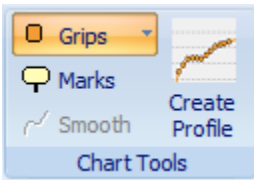
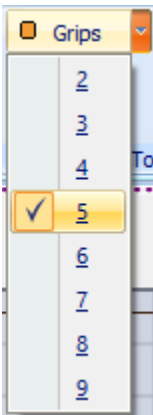
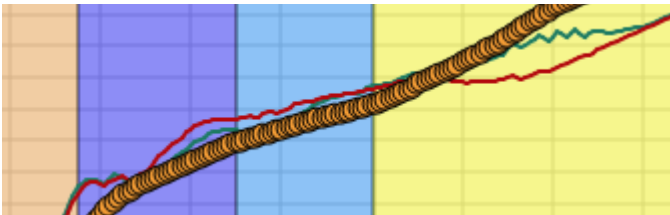

Chart Tools are used for plotting the Profile graphing. **Grips** is a term that is used in the Profiler to describe individual data points. A **thousand** Grips are typically used to plot a driveshaft curve.

This is what Grips look like when plotted. Each individual Grip can be moved, or a range of Grips can be selected and moved, curved, smoothed, etc.



The display size of the Grips can be changed. The default setting is 5 which seems to work well. The larger the number, the larger each grip will visually display.



Think of **Marks** as labels that show the Time and RPM

values at each data point. In the Timing window, marks show time and timing values. Marks can be toggled on and off for both the Profile window as well as the Timing window areas of the screen.

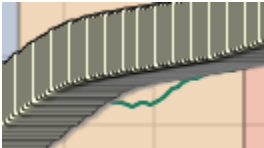

Profile Marks On. Display shows both Time & Driveshaft RPM along the Profile curve. Notice in full screen view there are so many that you must use **zoom** to be able to see the individual marks and data.

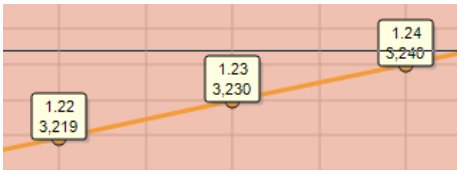

Timing - Marks on. Display shows Time and Timing settings at that point in time. Each Mark displays both the time line and timing degrees for each data point

Zoom view of the **Marks**.

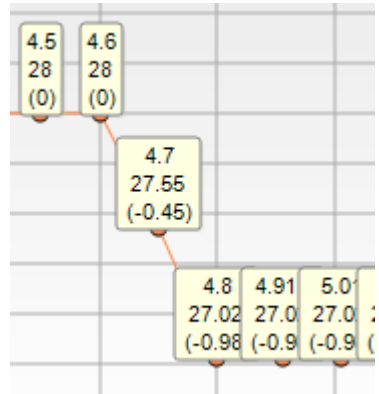

These are the Timing Marks using Zoom which makes it easier to see. Notice that when the timing was ramped down one degree, the data points in-between reflect the exact timing, in this case at 4.7 seconds the retard was -.45 degree.

The Profiler gives you precise control over engine timing!

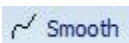

When a grouping of Grips is selected, the **Smooth** function becomes available. This is a powerful tool. If an imported driveshaft curve has some spikes, dips etc., the Smooth

tool will automatically perform a smoothing function to the grouping that was selected. Each time the mouse clicks on Smooth it will smooth the selected grips a little more.



Groups of Grips are selected using the keyboard and mouse. In this example notice some of the Grips are orange and a group of them is red. Once selected, they can be manipulated to create the desired driveshaft curve. This is effective in that you can fine

tune precise portions of the driveshaft profile that you want. It typically takes a little practice to get the hang of selecting groups of Grips.

To select a group of grips, place the mouse pointer over one end of the Grips you want to start with. Select **Ctrl >left mouse click** on the starting point. You should see the Grip change color to **red**. Next **Shift >left mouse click** the end point of Grips you want to select. Now the Grips between those two points are selected and will appear red which indicates they are now a “group”. If you want to unselect the grouping for some reason, press the **>Esc** key. At this point in time there is no Undo option once you move them.



Create Profile is applied after importing driveshaft data from Racepak. The driveshaft curve or curves that are imported are utilized to create the series of Grips that make up a Profile. A Profile can be created from either a single set of driveshaft data or from multiple driveshaft curves. This is another impressive feature of the Profiler as it can use several passes of driveshaft data and create a single profile by averaging all of them together, it’s that easy! From that point you can customize the profile as you wish.

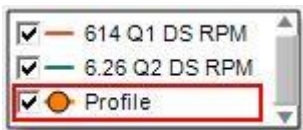

On the far right side of the Profiler window there is Legend window that displays the imported runs that have been imported along with the current

Profile. You can select or de-select the runs you choose to display.

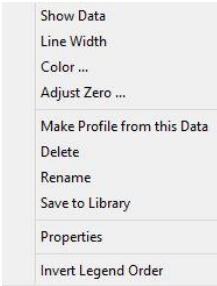

By right mouse clicking on any of the imported runs, you will see this popup window appear. This provides you with several options. Most of these options are self-apparent as to their function so we will only discuss the one's that aren't.

#	Time	RPM
0	0.00	2
1	0.01	2
2	0.02	2
3	0.03	2
4	0.04	2
5	0.05	2
6	0.06	241
7	0.07	483
8	0.08	429
9	0.09	372
10	0.1	465
11	0.11	561

Show Data displays 1,000 driveshaft data points of an imported data logger run.

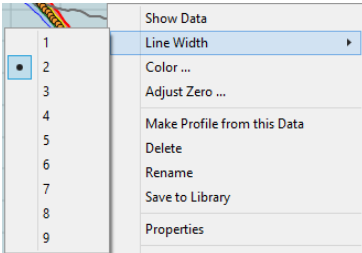

The **Line Width** option gives you control over the line width of each data set you have imported. The default setting is 2.

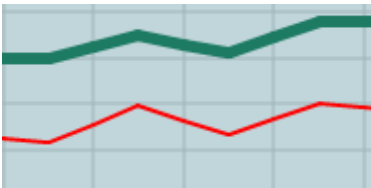

In this example, the **red** line is at the default setting of 2 and the **green** line was adjusted to a setting of 6.

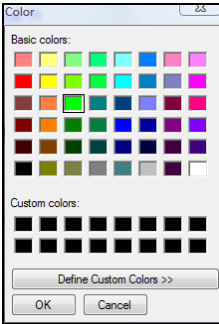

Select > **Color** option will present you with a color pallet to choose from for the chart data you selected.

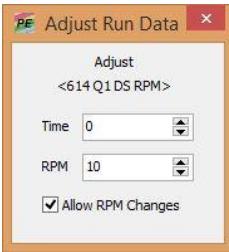

Select >**Adjust Zero** option allows you to fine-tune the zero position of the imported run you selected.

Select >**Make Profile from this Data** option will immediately create a Profile from the selected run. When you select this option a warning popup window will appear.

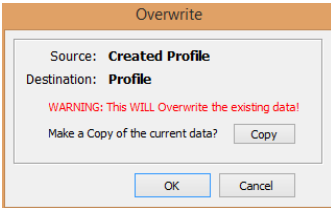

NOTE: You cannot have more than one Profile open at a time. Run data is NOT a Profile, a Profile is created from run data.

This is warning you that if you proceed, it will overwrite any existing Profile this is currently on the screen. It does give you the option to have the system make a copy of the current data if you wish to keep.

If you don't copy the currently displayed profile or Save it, it will be gone as there are NO un-do options available at this time. A good habit is to frequently perform Save's or Copy if you want to revert back to previous changes.

The **Save to Library** option will store the selected run data into the \Library\Runs folder where data logger and previously saved runs are stored.

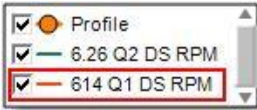

Selecting the **Invert Legend Order** reverses the order of the items displayed in the legend window.

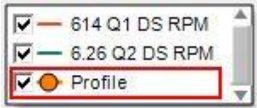

The **Profile** entry in the Legend window has its own set of properties...

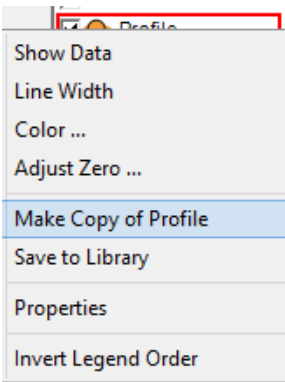

>Right Mouse Click on the Profile in the Legend box and it gives you an option to **“Make Copy of Profile”**. It is suggested you use this to make a copy and name it **“AsRun011215Q1”** as an example. If you make changes for the next run, use this Profile copy to tweak so you always know what Profile was used for what pass. It’s very easy to get confused and not really know what Profile went with which pass.

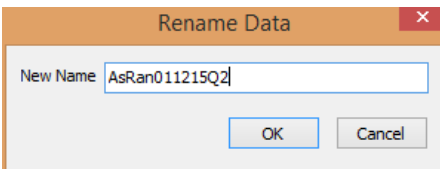

Use a meaningful name like the one shown, that easily identifies what run(s) were used with this Profile.

The **Correction Ranges** partition is shown below.

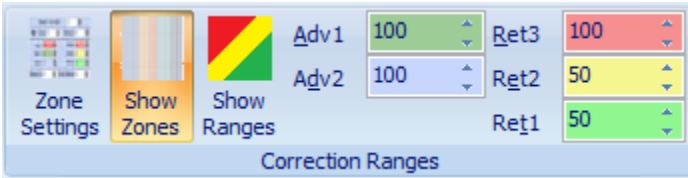

Zone Settings is a strong feature of the Profiler. Each Zone will make corrections in timing as the car goes down the track. This allows you to program multiple “zones” in your Profile, and then apply settings to each zone. An example might be your first zone may be from launch to 1.5 seconds into the run. You can apply a set of parameters for that first 1.5 seconds, and then apply a different set of parameters from 1.5 to 3 seconds for example.

Clicking > **Zone Settings** icon toggles **the Zone Settings** window On and Off.

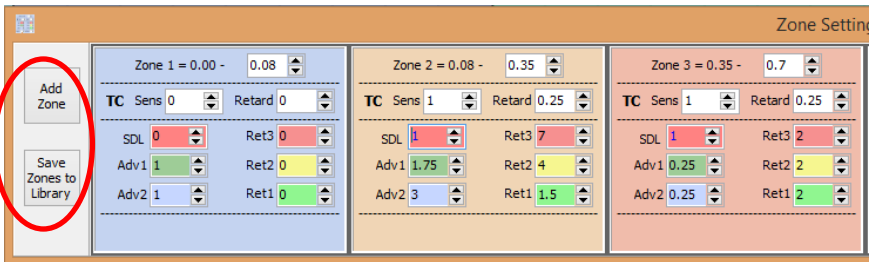

In this example there are three separate zones set up. Each zone has its own range of settings you can program. You can also add, delete, or save zones to the library **Zones** folder using the on-screen buttons in the left side of the window.

Zone 1 will always be there by default. Notice it begins at the start of a run, 0.00. The option is to set the end time, as in the example above Zone 1 is from launch to .08 second. Zone 2 is from .08 second to .35 seconds and so on.

TC (Self-Learning Traction Control) has a sensitivity setting adjustable from 0-5. With a setting higher than zero , sensitivity is increased proportionally. The **Retard** range available is **0 to a maximum of the number of degrees of timing you enter in Ret3.** (Whatever the **TC Retard** value is set to, it cannot pull more than the value of **Retard 3**)

SDL (Smart Drop™ Limit) is a unique Profiler feature that will “smartly” drop random, (never the same twice) cylinders to create small reductions in power if required (Setting of 1 = approximately 12%). The setting range is **0-4**, with 0 being it will not drop any cylinders and 4 being the maximum it will drop.

Note: With a Smart Drop™ Limit setting of 1, when the driveshaft RPM reaches approximately 76% of the **Red Correction Range** zone it will become active. If the setting is 2 it will become active when **DS RPM** reaches approximately 52% of the Red Correction Range setting.

Another of the Profiler’s unique features is it has the ability to dynamically **advance** timing if the driveshaft RPM drops below the Profile RPM threshold that is created. The advance function has two ranges of timing advancement, **Adv 1** and **Adv 2**. Each has a minimum of 0 degrees to a maximum of 20 degrees.

If the driveshaft RPM exceeds the Profile threshold there are three timing retard ranges available to correct the slip. These are **Ret1, Ret2, & Ret3**. Each has a range of **0 to -20** degrees of retard.

Ramp In (*Implemented in software release Version 2.1.0.293*). The range of settings is 0-500. The **Ramp In** function gives you the ability to control the rate at which the Profiler ramps the timing back in after a correction. This makes for a smoother application rate of correction.

The Timing Corrections log below shows corrections without Ramp In.

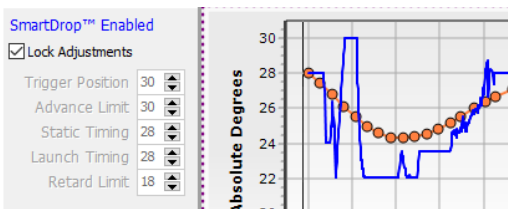

The next log shows what the corrections look like with the Ramp-In feature turned on. You can see the difference in the rate that timing is ramped back in.

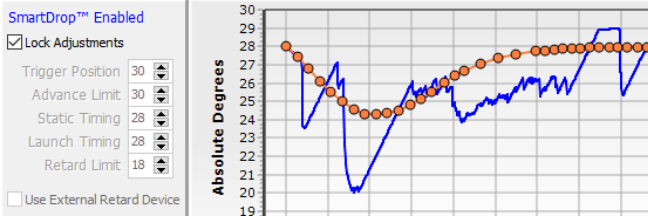

At the present time, to implement Ramp In, it is accessed through the Profiler touch screen only. From the main flash screen, Select **>Profiler**

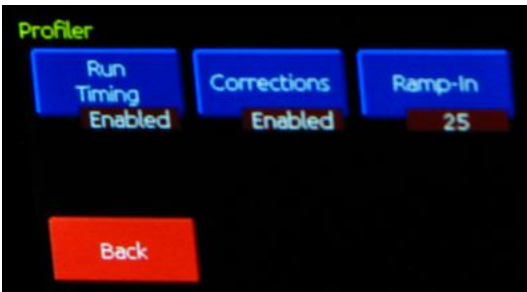

Select **>Ramp-In**

Enter the Ramp-In value you wish to use.

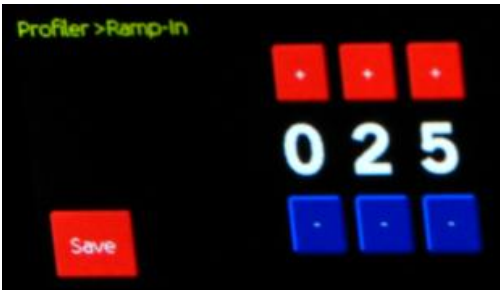

As a “rule of thumb” it is suggested to start with a value 10X your maximum Zone retard values. For instance, if you have a maximum retard value of 2.5 degrees, set the Ramp-In Value to 25 and so on.

Zone Blend (Not Yet Implemented). The setting range is 0-25.

Once your zones are programmed, the **Show Ranges** button will display the **Zone Settings** along with the Profile trace.

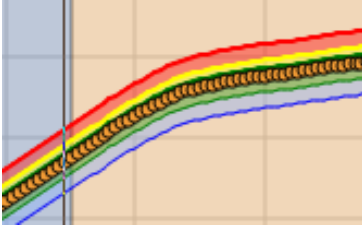

Zooming in, you can see much greater detail of how the zones appear in comparison with the Profile.

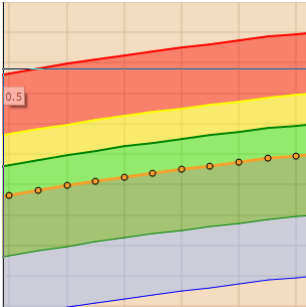

Each color corresponds to the colors in the **Zone Settings** window. The line with the orange Grips is the actual Profile line.

Each Zone has its own set of Properties. Right Hand click with the mouse inside the Zone you wish to change. You will see the properties drop-down menu

appear.

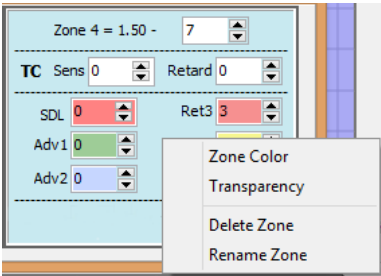

Zone Color allows you to change the color of each zone. Selecting it will pop up a color palette to choose from.

Transparency changes the zone color saturation transparency level of all the zones on the PC display.

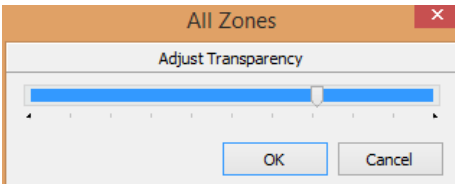

The slider adjusts the level. Set to what appeals to you.

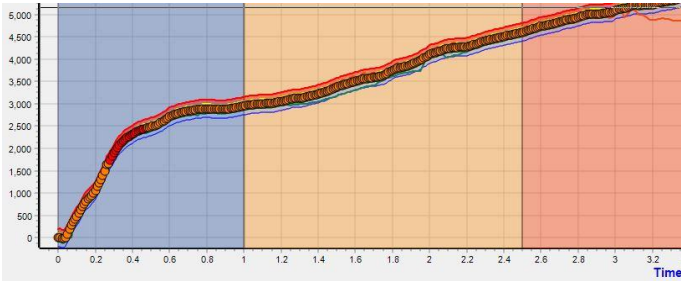

Example of Zones in the Profile window.

The **Delete Zone** and **Rename Zone** functions are self-explanatory.

Each Zone has a set of parameters for timing Advance and Retard as to the amount of timing that will be added or retarded plus you can set the RPM range for each as to how many driveshaft RPM above and below the Profile curve they are applied. It's like a zone within a zone so to speak.

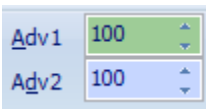

There are two driveshaft RPM setting ranges for timing Advance.

Advance 1 range is 0-1000 RPM.

Advance 2 range is 0-3000 RPM.

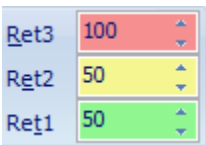

The Retard function has three driveshaft RPM ranges or "bands" for timing corrections. These are default but can be changed to what you find works best for your car.

Retard 1 range is 0-1000 RPM.

Retard 2 range is 0-1000 RPM.

Retard 3 range is 0-3000 RPM.

The **Cursor** section provides some nice cursor tools for navigating the Profiler user interface.

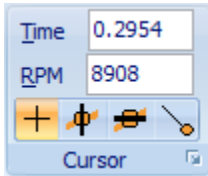

The **Time** and **RPM** boxes provide real time feedback from the mouse cursor positioning in the Profile window. The cursor options give the user a choice of how they wish the cursor to respond to mouse movement as far as alignment etc. We would suggest you simply try the various options to see how they look and feel on your PC. You will notice that if the cross hairs cursor is selected, there are two other options that work in conjunction with it, one for X axis and one for Y axis. If the cross hair cursor is not selected, those two options will be greyed out (not available)

NOTE: If the crosshairs cursor is selected, and you have both the Profile window and Timing windows displayed, moving the cursor will provide a reference line simultaneously.

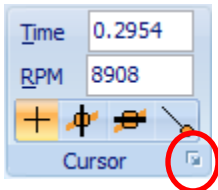

Clicking in the lower right corner of the Cursor section will result in a pop-up Cursor box to appear on the screen.

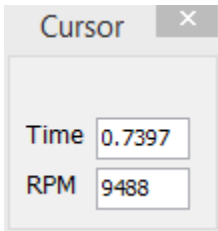

The **Cursor** box can be moved anywhere within the Profiler screen area and provides real time feedback from the mouse movement in the Profile screen for Time and driveshaft RPM.

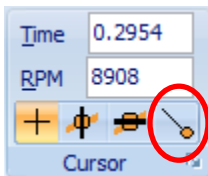

Selecting the cursor shown gives you some unique capability when developing your Profile. It will show you the difference in time and RPM between your Profile graph and other Run

graphs.

Let's take a look at an example.

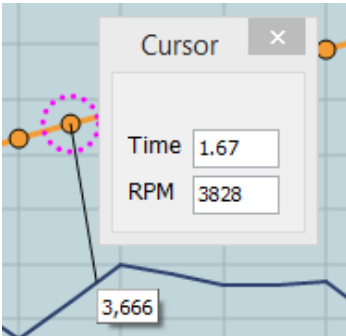

In this case, the orange line is your current Profile and the green line is a Run graph. The red circle will automatically follow your Profile line and the end of the handle is what you move with the mouse to the other point you wish to use as a reference.

To see the difference in RPM between the current Profile at any given point along the line and another run that is displayed, drag the handle down to the Run line and the RPM of the Run line will pop-up. Now you can see **both** the RPM of the Profile at that point and another run at the same point in time.

This can be useful to know how far above or below your Profile is from other Run lines or Profile lines that are being displayed.

4.0.2 Maximizing Screen Windows

There will times you choose to maximize the size of the Profile window and minimize the Timing window portion of the screen.

Profile Window

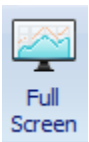

With the Profile portion of the window selected, Select >**Full Screen**.

Return to normal screen size Select >**Full Screen** again.

Timing Window

With the Timing Window portion of the window selected, Select >**Full Screen**. Return to the normal screen size, Select >**Full Screen** again.

4.0.3 Timing Window

The **Timing** window can be toggled in and out of the main screen. You will see a Timing tab on the UI. When the Timing section is toggled Off, the Profile screen will expand to full screen.

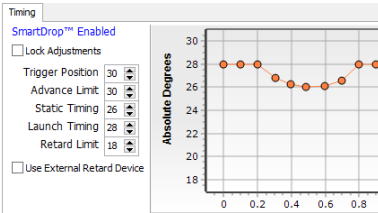

The Timing window is shown here.

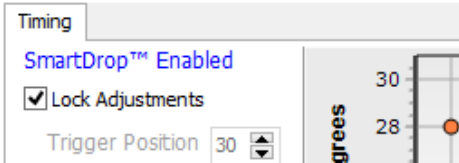

Lock Adjustments locks the settings options below it so they can't be changed. It *does not* affect timing.

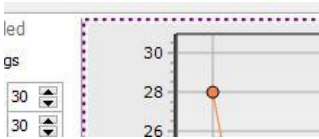

Notice that whichever window (Profile or Timing), the active window will have a purple dotted line frame indicating this window is active.

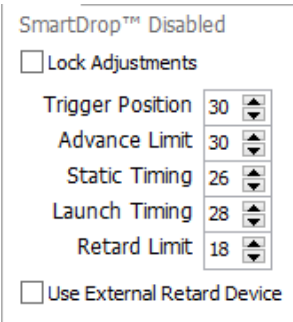

The baseline Timing parameters are located at the left side of the Timing window.

It will indicate whether a Smart Drop™ parameter was used in the Zone settings. In this example, Smart Drop™ was NOT used so indicates "Disabled"

If the **Lock Timing Settings** box is checked, parameters in the options boxes will not be available to edit.

Trigger Position

This is a reference point for the highest amount of timing you want to run the engine. (with the Profiler turned **OFF**, set this with your timing light), i.e. as the example above set timing to 30°.

Advance Limit

This is the highest timing reference you want with maximum timing Profiler will advance. (up to the **Trigger Position** setting)

Static Timing

Set Static Timing to your desired crank trigger timing. (when Profiler is turned **On** it will retard timing to this setting. Profiler turned **OFF** and timing will be at the **Trigger Position** setting)

Launch Timing

Set this value to the amount of timing you want for Launch.

Retard Limit

Set this value to the minimum number of degrees timing you want the Profiler to retard from your Static Timing. Example, if static timing is 28° and you set your Retard Limit to 18°, the Profiler can pull out up to 10° maximum timing retard.

NOTE: In a nitrous application, you will be pulling timing for each nitrous kit. To calculate minimum timing, you must **ADD** your total retard being pulled by your ignition system **PLUS** the amount of retard you set the Profiler limit at.

EXAMPLE: If you normally run your engine with all the nitrous kits on at 5° that only leaves you with 5° more timing to pull to get to 0, so use caution!

Use External Retard Device

You can send the 0-5v timing signal out to an external retard device, like a Digital 7 (7531), Lahey Command Module, or others.

More Clarification

In the example above, the crank trigger timing is **26° and the Trigger Position** (Reference Point) is **30°**

Since the **Advance Limit** was set to **30°** the Profiler will be able to Advance timing up to **4°**.

Since the **Retard Limit** was set to **21°** the Profiler will be able to Retard timing up to **5°**.



It is crucial you understand these settings! If not, you

could possibly cause engine damage from too much timing with incorrect parameter settings.

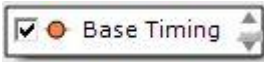

The **Base Timing** region of the screen has it's own Legend. Right mouse clicking on any entry will open a property window similar to the one for Profile.

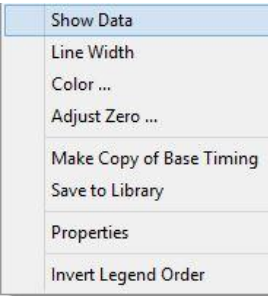

Selecting **Show Data** will display the timing data in a table format like the Driveshaft data in the Profile window.

#	Time	Degrees
0	0	28
1	0.1	19.99
2	0.19	19.99
3	0.3	20.06
4	0.39	19.99
5	0.5	16.01
6	0.57	16.09
7	0.64	16.09
8	0.71	16.09
9	0.82	12.04
10	0.92	12.04

The **Base Timing** window displays both Time and Degrees of timing. The data can be edited if desired in the table to make exact time & timing changes.

There are several other Tabs at the top of the Profiler window. The **Profile** tab you just discovered is where most of the work is done to build driveshaft and timing profiles.

Adding Profile and Timing Grips

When you are editing the Profiles moving Grips around, you will see the space between grips increase. To increase the resolution of the data you will want to **add** grips in the area(s) where there is a lot of space such as the example below.

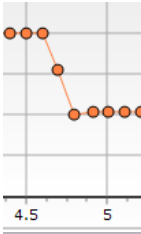

To add grips in the area selected use the same process as you used earlier to select a range of grips:

Ctrl >Left mouse click

Shift >Left mouse click

Now **Ctrl >Right** click which will then open the window below.

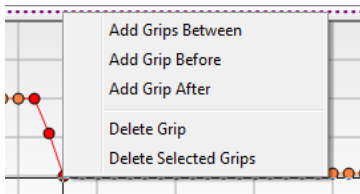

In this case “**Add Grips Between**” was selected.

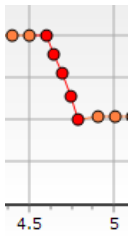

You can see where the Profiler added grips between the points selected. As mentioned, this will increase the resolution of the data the profiler is working with, making it more accurate, making timing adjustments in smaller increments resulting in an overall smoother application of timing retard or advance.

4.0.4 Control Tab

The **Control** tab is shown below. There are three functions within this section.

The **Download** and **Upload** functions are used to load Profiles, download **run** files, and make Settings changes.

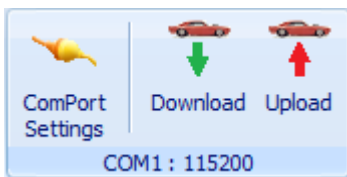

For several functions, you must be able to communicate to the Profiler from your computer through its communications port. The settings will likely only need to be during the installation of the system. Please notice that in the screen above, the window displays which Comm port is selected and the associated Baud rate. Clicking on **ComPort Settings** will open the screen below:

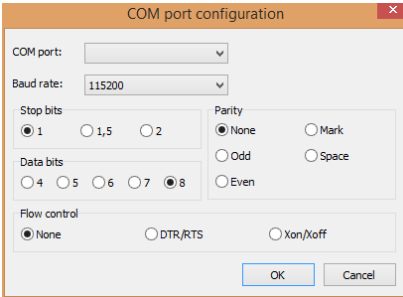

These default settings work well. You will want to make sure your PC Port settings match these. Normally they will default to the same as this example. See the **Appendices** for Davis COM port installation on your PC's operating system.

Uploading Profiles to Profiler

Once you build Profiles, you will need to Upload a Profile in order to use it for a run. From the main Profiler screen, go to the menu bar **Control** tab and Select **>Upload**

See the Software Installation section for proper Com port driver installation and troubleshooting if you are having issues communicating between your PC and the Profiler.

The screen below will open.

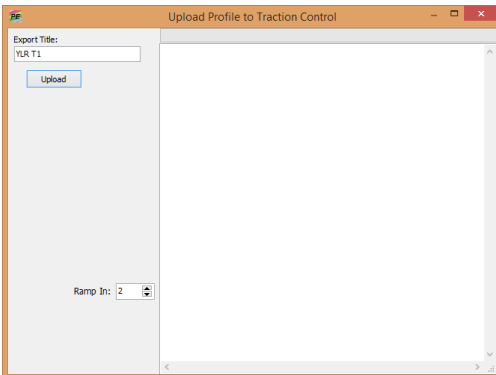

The name of whatever Profile you have active on your screen, should populate the **Export Title** field.

Select **>Upload** and you will see data transferring (scrolling) within the window until it's complete. You will get a "Upload Finished" when complete.

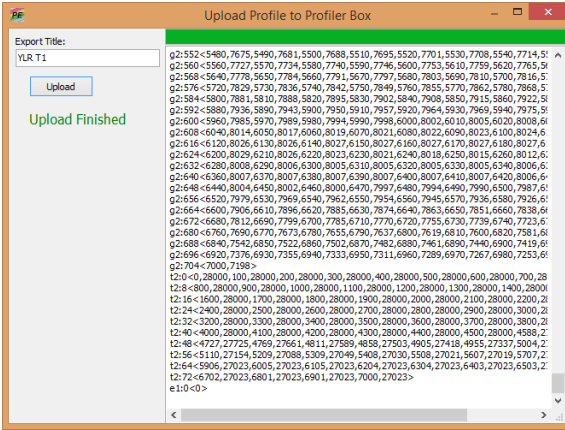

NOTE: If you keep getting an Upload Error and no data will transfer, check that there are **NO** Profile grips below 0 RPM. This is a common error people make.

Loading and Selecting Multiple Profiles

The Profiler can store up to 6 Profiles that can quickly be loaded through the touch screen utility.

If track conditions change, you maybe want to try a quicker Profile because you ended up getting a single run at the last moment, etc. you can easily change to one of the different Profiles you stored.

To load multiple Profiles first save the Profile that is currently loaded by selecting **Main >Utilities >Save Profile** on the touch screen. It will then display the screen that has the buttons for up to six Profiles. Select the button location you want to store the Profile and you will see it save the Profile. To load more Profiles, send the next Profile from your PC to the Profiler and repeat the process until you have the one's you want loaded.

After completing the process, to change to a different Profile, select the **Change Profile** button on the main menu of the touch screen, the screen that has the 6 Profile buttons will open, then select the Profile you wish to load. You can load and store new Profiles which will overwrite the file linked to the button you select for storage.

Downloading Run Data

Once you have made a run, you will want to download the **Run** data and **Corrections** data so you can analyze and save it.

You will be presented with multiple Save options. Typically you will download **ONLY** the Run since you already have a Profile and its associated information for Events, Zones, System Options, etc. The only time you may want everything downloaded is if you would be sending the information to someone else such as Davis Technologies so they could look at what all the Profile settings are.

Selecting **>Run Data** will download Run Data and Corrections data.

You will see the data saving indicator for 10 seconds or so on the Profiler touch screen. Once the data is saved, turn the power back off, and connect your PC to the Profiler with the USB cable.

Connect your PC to the Profiler using the USB cable or Bluetooth.

Open the **Profiler Editor** application on your PC

Select **>Control** tab on the top menu bar

Select **>Download** and you will see the window below.

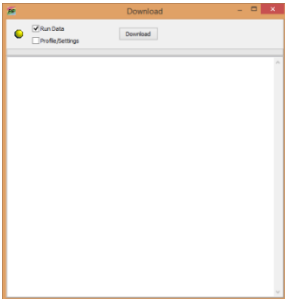

There are only two options when downloading files from the Profiler. You may choose not to download the settings which makes the download quicker.

- **Run Data**
- **Profile Settings**

Select **>Download**

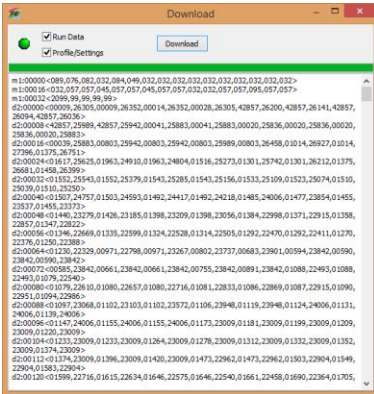

Once data begins transferring, you will see the data scrolling in the window until complete.

When the download is complete you will see the last run driveshaft RPM profile in the top(driveshaft RPM) window and the timing corrections appear in the lower (timing) window.

Important...You will want to name each of these new files, again,

something meaningful such as the same name as the data logger file for instance. As mentioned multiple times, the naming is critical in keeping track of all these files.

Rename & Save the **Run Data** in the **Davis Technologies/Profiler/Library/Runs** folder and the timing corrections data in the **/Corrections** folder. Good, consistent, file organization can't be stressed enough for future reference and reviewing of files.

The following is a sample of downloaded timing corrections data.

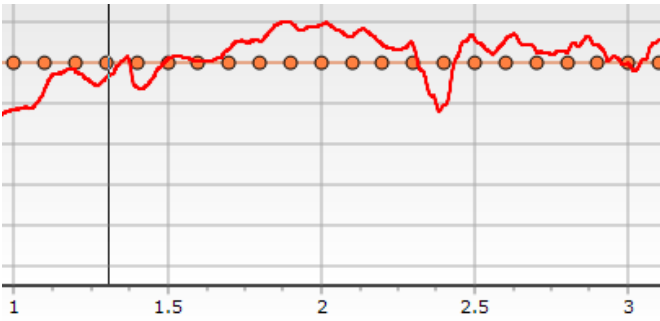

You can see the base timing profile Grips as well as the downloaded data timing corrections. Anything above the base timing profile is where the Profiler added timing and everything below is where it retarded timing. You can load multiple correction runs into the window for comparison. Once you get a few runs of data, you will want to customize your base profile to minimize the amount of

corrections required to optimize performance and minimize timing changes and smooth power application.

One of the Properties (Right Click >File Name in the legend window) is to **Make Base Timing from this Data**. If you select this option, it will ask if you wish to save the current base timing profile. If you want to save it, do it now otherwise it will be overwritten. If you proceed, the software will build a new timing profile based on the current run data.

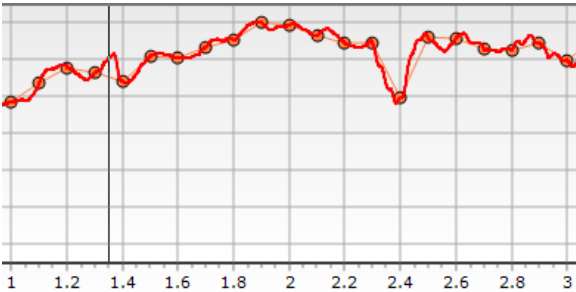

From this point, use the new profile but use the tools discussed previously to smooth it out some as shown below. Over time you will likely refine it more as you get more data.

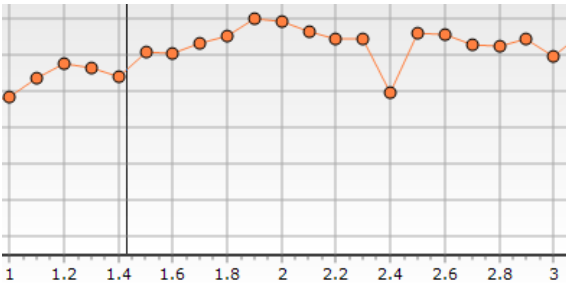

What quickly becomes apparent is the Profiler is telling you what your car wants to go quicker and faster which is a huge plus in tuning your engine and chassis. The Profiler once again demonstrates it's an impressive tool in many respects.



Notice more grips were added in this area, in addition to the smoothing to increase the data resolution.

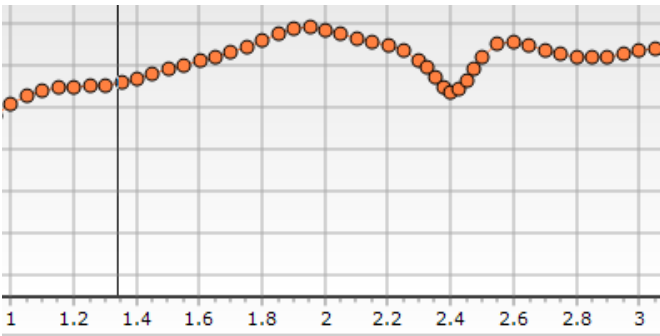

4.0.5 Settings Tab

The **Settings** tab provides access to configure **Profiler** modules. Selecting the tab will open the window below:

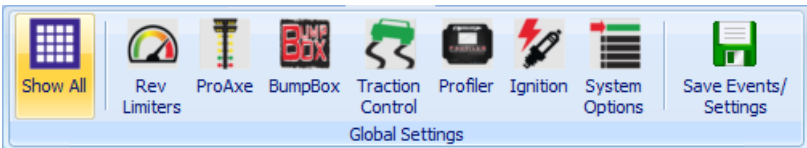

The **Show All** button opens the windows for all of the options with one click if you need to access all of them. Otherwise you can open the one's you want individually.

- **Show All** – Shows all the module option settings with one click.

- **Rev Limiters** – Sets Pre-Launch and upper Rev Limits.

If you wish to use your current Rev Limiter solution, set both of these settings **higher** than your ignition box limit settings.

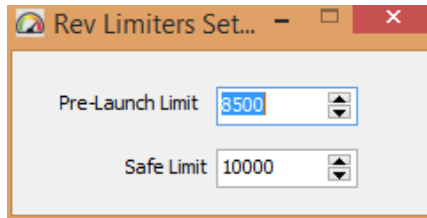

- **ProAxe** – Basically it's a delay-box with an adjustment range of 0 to 9.999 seconds.

Set it to 0 if you are not using it or if you are NOT using Profiler to control the Trans-Brake

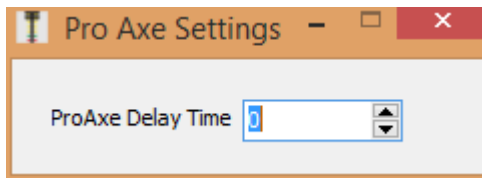

- **Bump Box** – The Bump Box setting controls the aggressiveness of each "bump". A setting of .040 is a good starting point. The higher the setting the more aggressive.

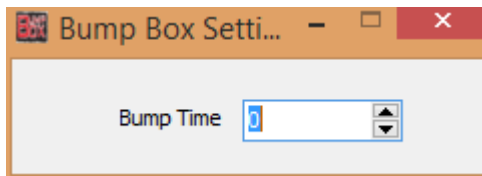

- **TC Settings** – You can enable or disable Traction Control using this window.

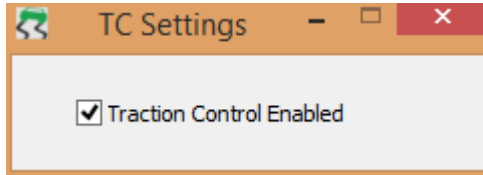

- **Profiler Settings** – Use this window to enable or disable using the Profile and toggling whether timing corrections are enabled or disabled.

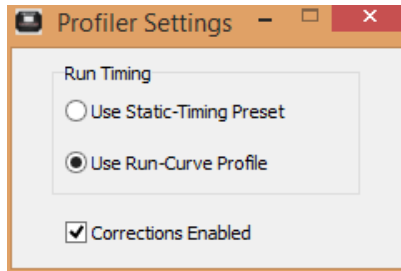

NOTE: If you choose to run the car with the Profiler timing curve & corrections disabled use the following settings:

1. **Uncheck** Use Run Curve Profile and Corrections Enabled
2. **Check** Use Static-Timing Preset
3. Upload the Profile or use the Profiler touch screen menu >**Main>Profiler** to make the changes.

The car will now run using the **Static Timing** value you entered in the Timing window. (NOT the actual crank trigger setting)

- **Ignition Settings** – This window is for setting the ignition options or not using the Profiler for ignition. Also the **Smart Drop™** option can be enabled or disabled here.

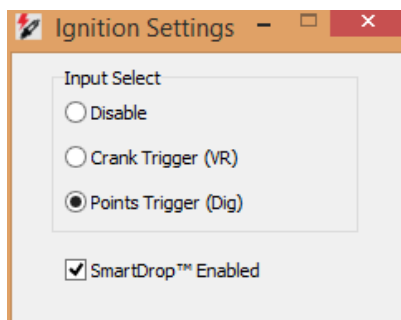

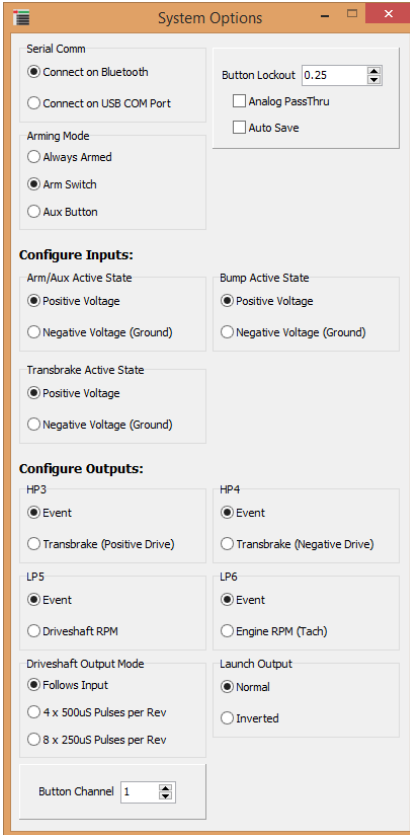

System Options

Serial Comm – Sets whether you will connect to the Profiler via Bluetooth or a USB cable

Arming Modes:

Always Armed - The Profiler will be armed any time there is power applied.

Arm Switch – A toggle switch is being used.

Aux Button – A separate button is being used.

NOTE: Momentary switches must NOT be used at this time.

Analog Pass Thru – (future use)

Auto Save – Run data is saved after a run when power is applied again.

Configure Inputs:

Arm/Aux Active State - Set to either a Positive or Negative Voltage.

Bump Active State - Set to either a Positive or Negative Voltage.

Sync (Transbrake) Active State – Set to either Positive or Negative Voltage.

Configure Outputs:

HP3 – Set to either Event or Transbrake (Pos Drive)

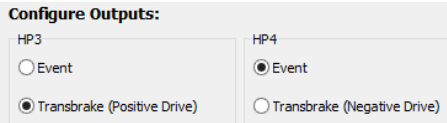

In this example, the **HP3** Event is set to Transbrake (Positive Drive)

When you select **Events >HP3** this message will now display:

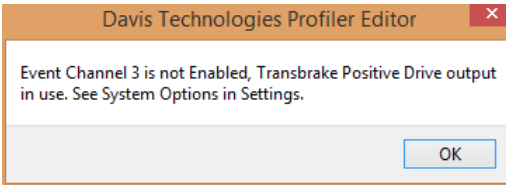

HP3 is now dedicated to the Transbrake function. The same would occur if you configure HP4 for the Transbrake.

HP4 – Set to either Event or Transbrake (Neg Drive)

LP5 – Set to either Event or Driveshaft RPM

LP6 – Set to either Event or Engine RPM (Tach)

Launch Output – Set to **Normal** (+) or **Inverted** (-) depending if you want the output to be + voltage or a ground (-). Use this if you have some component that requires a + or – to activate while on the Trans-Brake as an example.

NOTE Speedwire Systems™ Users:

If you have a **Speedwire Systems™** setup in your car, there is an input on their 8 circuit car controller board that activates the trans-brake circuit. That input wire needs to be Negative when activated. That is the Profiler Blue wire Pin 20.

Speedwire Systems™ Integration see **Appendix 11**

Driveshaft Mode – Some systems such as Big Stuff 3 only support 2, 4, or 40 pulse inputs so use this function to configure what is required. **The 4 and 8 pulses options are only used when sending driveshaft RPM to an external device such as BS3 etc.**

- Follows Input (default)
- 4 x 500uS pulses per revolution

- 8 x 250uS pulses per revolution



Button Channel – This allows you to select one of the 8 Events Channels to use the Button trigger option. The BumpBox wire (Pink) can be used to activate any of the 8 **Events** in addition to the BumpBox.

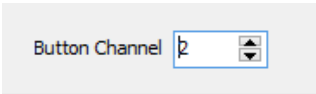

Whatever Channel is selected will be made active by pressing the button at any time the Profiler is powered up

prior to trans-brake and run.

For example: You might want to shift the transmission during the burnout or activate some other Event you have programmed prior to staging and launch. In this case pushing the button prior to the trans-brake/launch sequence would trigger Event 2. After launch the same button can be used to trigger any of the 8 Events as long as the Event Trigger Condition is set to **Button** only or **Button or RPM**.

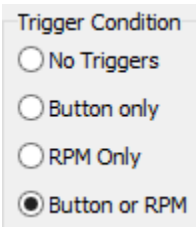

Setting **Button only** will only trigger the Event by pressing the button (Pink wire-BumpBox input).

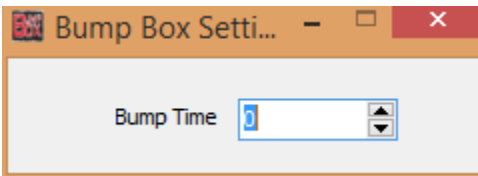

You do NOT have to use the BumpBox in order to utilize this function, simply set it's parameter to 0 and it will do nothing.

Setting to **Button or RPM**; pressing the Button before the RPM setting is reached will trigger the Event or once the RPM setting is reached it will trigger it.



Save Events/Settings – This option allows you to save your Profile Events & Settings into the Profiler Library so you can import them into another Profile without having to input all the settings again.

NOTE: These Settings will transfer with the uploaded Profile's from your PC. You can verify by using the touch screen menu's to view current settings. If you make a change on the Profiler using the touch screen, and you download a Profile, those changes will be reflected in the file.

4.0.6 Events

The Profiler provides 3 high power (30 Amp) **Positive** and 1 **Negative** programmable outputs for your use. It also has 4 low power (750 mA) **Negative** outputs. See the **Wiring Plug Pinouts** table in Section **2.5.10** for the detailed connection information.

(Notice **Red** icons are + outputs, **Green** icons are – outputs)

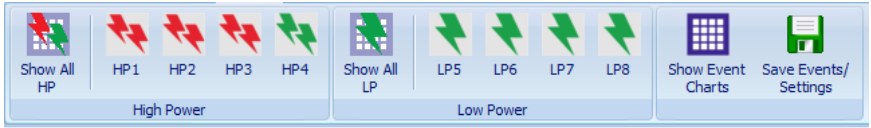

Below is the parameter window for **HP1** as an example. Each output has options for up to 8 different “Event” settings.

How “Events” Work

Think of power Events with multiple “triggers” i.e. On, Stay On, Off, etc. With 8 Event sub-actions available it provides plenty of options to turn things on, off, back on, ramping, etc. Events can be triggered by Driveshaft RPM, Engine RPM, or Button.

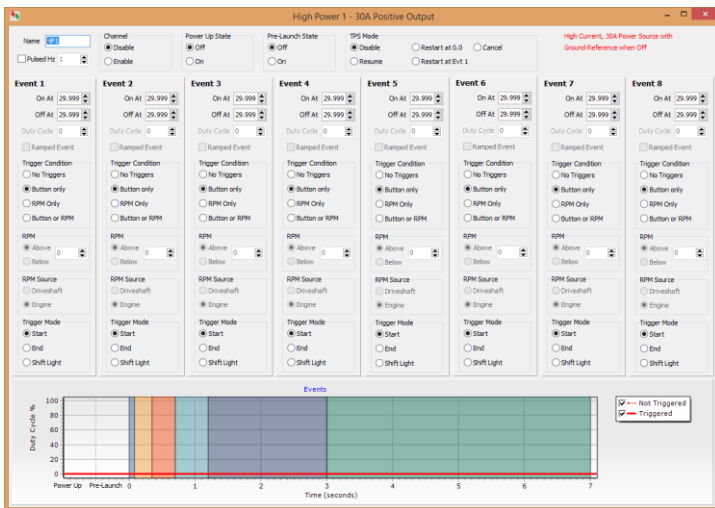

The screen capture above is for one of the high power events. As you can see, there is also a chart below that reflects the programmed settings. The one shown is using default settings.

The screenshot shows the configuration panel for 'Event 1'. At the top, the 'Name' field is set to 'HP1'. Below it, the 'Pulsed Hz' checkbox is checked and set to '1'. The 'Event 1' section contains: 'On At' and 'Off At' spinners both set to '29.999'; 'Duty Cycle' spinner set to '0'; 'Ramped Event' checkbox is unchecked; 'Trigger Condition' section has radio buttons for 'No Triggers', 'Button only' (selected), 'RPM Only', and 'Button or RPM'; 'RPM' section has radio buttons for 'Above' (selected) and 'Below', with a spinner set to '0'; 'RPM Source' section has radio buttons for 'Driveshaft' and 'Engine' (selected); 'Trigger Mode' section has radio buttons for 'Start' (selected), 'End', and 'Shift Light'.

Name the event

Pulsed Hz setting if needed. (0 = 100%)

Event range “windows” are set with **On AT** or **Off At** at specific times up to 29.99 seconds. Events will occur inside the window range you set. If set to 0 it will become active immediately.

Duty Cycle is available for Pulsed Hz

Ramped Event is available for Pulsed Hz (0=0% 100=100%)

Trigger Condition:

- No Triggers
- Button only
- RPM Only
- Button or RPM

RPM:

- Above
- Below

Below acts as On >Inverted (-) when triggered.

RPM Source

- Driveshaft
- Engine

Trigger Mode

Start – Upon release of the trans-brake

End – End of the run

Shift Light – Activation of the shift light

Start – Power ON at specified parameters

End will end an event at the specified parameters.

Shift Light Mode indicates the Event will trigger then turn off immediately.

An event ramping function is available. Ramping can **Disabled** or **Enabled**

Note: If Event is set to “**Start**” and Ramped Event is selected, the event will ramped **Up**. If the Event is set to “**End**” and Ramped Event is selected, the event will be ramped **Down**.

The screenshot shows a configuration panel for an event named 'HP1'. It includes several sections:

- Name:** HP1
- Channel:** Radio buttons for 'Disable' (selected) and 'Enable'.
- Power Up State:** Radio buttons for 'Off' (selected) and 'On'.
- Pre-Launch State:** Radio buttons for 'Off' (selected) and 'On'.
- TPS Mode:** Radio buttons for 'Disable' (selected), 'Resume', 'Restart at 0.0', and 'Restart at Evt 1'. There is also a 'Cancel' button.
- Pulsed Hz:** A checked checkbox and a dropdown menu set to '1'.

Channel

- **Disable** makes Event channel unavailable.
- **Enable** makes Event available.

Power Up State

- **Off** will do nothing when Main power is switched On to the Profiler.
- **On** will make event happen as soon as Main power is applied to the Profiler.

Pre-Launch State

- **Off** will do nothing when Trans-Brake is applied.
- **On** will be active when Trans-Brake is applied.

TPS Mode (throttle position)

- **Disable** ignores the throttle position activity.
- **Resume** means if the car is pedaled, it will resume the Event from the point it was interrupted once full throttle is applied again.

- **Restart at 0.0** means if the car is pedaled, it will restart the Event from the beginning once full throttle is applied again.
- **Restart at Evt 1** means if the car is pedaled it will restart back at **Event 1** (the beginning) once full throttle is applied again.
- **Cancel** will cancel any TPS related Events after pedaling.

The TPS Mode can be used in conjunction with controlling a multi-kit nitrous system for example. Once again this shows the power and flexibility of the Profiler multi-function platform.

Event Behavior Graphic Display

The screenshot displays two event configuration panels, Event 1 and Event 2, within a software interface. At the top, a 'Name' field contains 'Shifter' and a 'Channel' section has 'Enable' selected. Below this are two main event configuration areas. Event 1 is set with 'On At' 1.1, 'Off At' 2, and 'Duty Cycle' 100. Its 'Trigger Condition' is 'Button or RPM', 'RPM' is set to 'Above 7200', 'RPM Source' is 'Engine', and 'Trigger Mode' is 'Shift Light'. Event 2 is set with 'On At' 2.3, 'Off At' 3, and 'Duty Cycle' 100. Its 'Trigger Condition' is 'RPM Only', 'RPM' is set to 'Above 7600', 'RPM Source' is 'Engine', and 'Trigger Mode' is 'Shift Light'. Both events have 'Ramped Event' unchecked.

When you program an event, at the bottom of window you will see a graphic representation of your parameter entries to help you validate your settings.

In this case it's programmed to control a three speed shifter. A "window" was set from 1.2 to 2 seconds, with Engine RPM 7200 or above and controlled either with a Button **or** RPM trigger. This allows the driver to short shift the transmission with a Button **or** automatically shift at 7200 RPM.

The 2nd gear shift has a window from 2.3 to 3 seconds and will shift with RPM **only** at 7600 RPM. Shift Light means is a one pulse voltage (On-Off) that triggers the shifter.

Below is the graphic depicting the programmed Shifter Events.

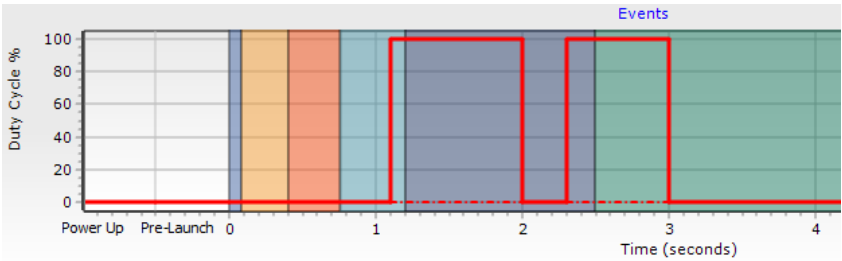

For examples of how to program different types of events and how they work see **Appendix 9**



Save Events/Settings – This option allows you to save your Profile Events & Settings into the Profiler Library so you can import them into another Profile without having to input all the settings again.

Show Event Charts

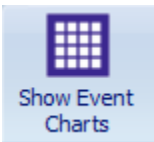

Show Event Charts will display a summary of all your programmed Events. You can select which one’s you choose to see.

In the example below it shows 3 Events:

- Event HP1 to control the shifter
 - 1-2 gear change from **Button** or **RPM** at 7200
 - 2-3 gear change from **RPM** at 7600

- Event HP2 to turn on the water injection at .7 seconds and ramp it to 1.3 seconds to 100% the rest of the run.
- Event 3 to activate the air chutes with the Button beginning at 5 seconds to the end of the run.

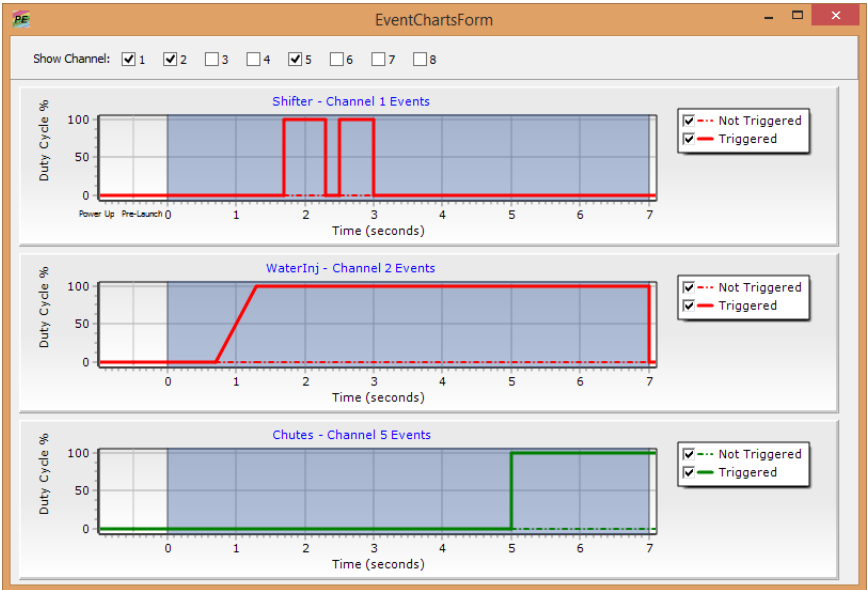

Before configuring and using Events, you must understand the following information.

A "connected" event (event within an event) is defined as an event that **starts** at the exact time at which the previous event **ended**. Any difference (even 1mS) between previous-end and current-start means it's unconnected and it will be handled differently.

Name <input type="text" value="HP1"/>		Channel <input type="radio"/> Disable <input checked="" type="radio"/> Enable	
Pulsed Hz <input type="text" value="20"/>			
Event 1		Event 2	
On At <input type="text" value="0"/>		On At <input type="text" value=".5"/>	
Off At <input type="text" value=".5"/>		Off At <input type="text" value="1.5"/>	
Above RPM <input type="text" value="1000"/>		Above RPM <input type="text" value="1000"/>	
Duty Cycle <input type="text" value="75"/>		Duty Cycle <input type="text" value="75"/>	
RPM Source <input type="radio"/> Driveshaft <input checked="" type="radio"/> Engine		RPM Source <input type="radio"/> Driveshaft <input checked="" type="radio"/> Engine	
RPM Mode <input checked="" type="radio"/> Start <input type="radio"/> End <input type="radio"/> Shift Light <input type="radio"/> Shift Light Inverted		RPM Mode <input type="radio"/> Start <input checked="" type="radio"/> End <input type="radio"/> Shift Light <input type="radio"/> Shift Light Inverted	
Ramped Event <input type="radio"/> Disable <input checked="" type="radio"/> Enable		Ramped Event <input type="radio"/> Disable <input checked="" type="radio"/> Enable	

Connected Event Example

“**Connected**” meaning Event 1 & Event 2 are interacting directly with each other.

Example: In this case if Event 1 ended at .5, Event 2 has to begin at .5 to be connected.

- Notice that Event 1 >Off At is **Green** and Event 2 >On At is **Green**. This indicates the two Events are Connected. If Event 2 On At was .51, it would no longer be a Connected Event and would be **black** text.

A connected event that is ramped will always ramp from the duty cycle where the last event ended to the duty cycle specified in the new event. In this example Event 1 ramped to 75% duty cycle so Event 2 has to begin at 75% duty cycle.

Unconnected, ramped events **must always be ramp-UP events**. They will start at zero and ramp up to the specified duty cycle.

If you want an unconnected event to ramp down, you must connect it to an event that sets the duty cycle for it to ramp down from. This can be a short (2mS), non-ramped event.

The duty cycle setting becomes the "target" duty cycle in all cases.

If you want a connected event to ramp down to off, you must set the duty cycle to zero.

If Events are NOT connected, you could have 8 separate events within one Output channel.



Button Event Trigger



The Button trigger is a unique function that should be considered. It can be used in conjunction with RPM for an "either or" activation scenario to trigger programmed Events.

A single button on the steering wheel could now be used to shift the car during the burnout, trigger the Bump Box while staging, then use the same button to short shift the transmission if there's tire shake, trigger a converter charge pressure solenoid, or activate a nitrous kit or activate the chutes as examples.

It enables you to have a single, programmable, multi-functional button that triggers multiple component control functions, all programmed and controlled within the Profiler. Use your imagination with this feature, there can be lots of uses for this. The button connects via the Pink Profiler wire.

4.0.7 Help Tab

As with any product after sale Support is the key to happy customers. The **Help** tab functions provide you with the ability to connect live to Davis Technologies for support through an Internet connection, download current software updates, view the current Editor software level, and view the latest **Profiler User Guide**.



Select **>About** icon will show you the current version of Profiler software that you are currently using.

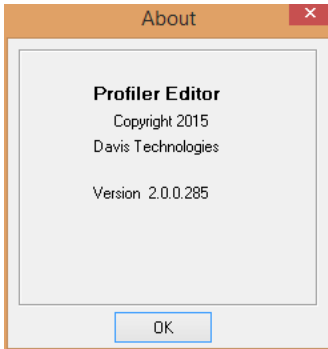

You used the “**Check Updates**” function when you installed the Profiler software. Check from time to time for updates or when directed by Davis Technologies to update.

Updates are in the form of software for your PC device and firmware for the Profiler hardware. **You MUST reboot or power Off/On after updating the firmware.**

4.0.8 Davis Technologies Support



Other than a phone call, the **“Team Viewer”** is your direct on-line connection to Davis Technologies for support. Once you are directed by Davis to activate your Team Viewer, you will have a direct live Internet connection that you and Davis can share desktops, video camera, etc.

This is a huge time saver in diagnosing, consulting, and working through various situations you may run into at the track etc.

When you click on Team Viewer, a pop-up window may appear asking if you want this program to make changes to your computer. Select Yes and the Team Viewer login window will appear.

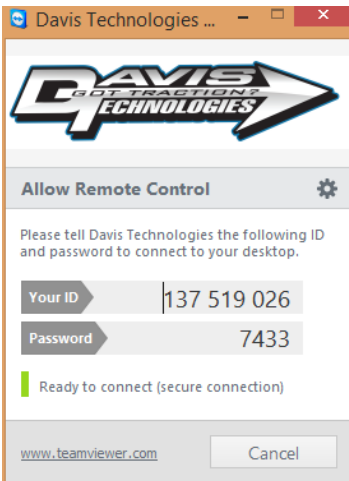

The Davis Technologies representative will ask you for the ID and Password showing in your window.

This is a fantastic support tool.

It’s as easy as that!

Click on either one of these pictures and it will download TeamViewer to your PC.



4.1 Exporting Logger Data

In order to build custom Profiles, you must load driveshaft data files into the Profiler as a starting point. This is much easier than having to manually build a driveshaft curve as a starting point. Racepak log files will be used in the following example.

- Open the file you wish to use in the Racepak DataLink II software.
- Zero the run with the MSD Launch or Trans-Brake event
- Turn all channels displaying **OFF EXCEPT for DS-RPM**

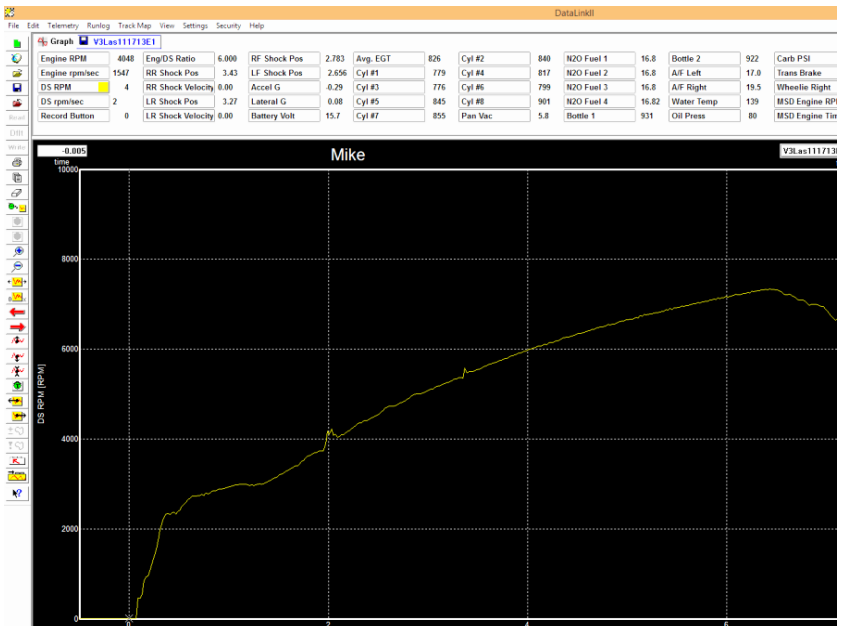

Select **>File**, then **>Print/Save Ascii Data** from the menu.

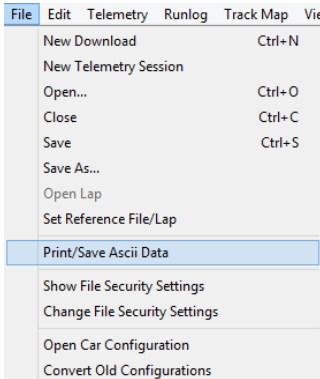

This window will display.

Select **>Print/Save Ascii Data**

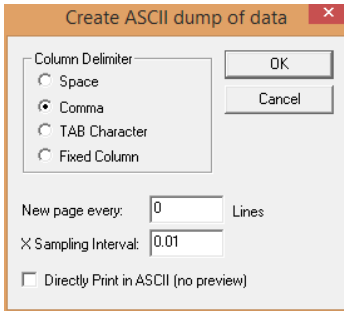

Select **Comma** and set

Set **>X Sampling Interval >0.01** as shown in this example.

Select **>Ok**

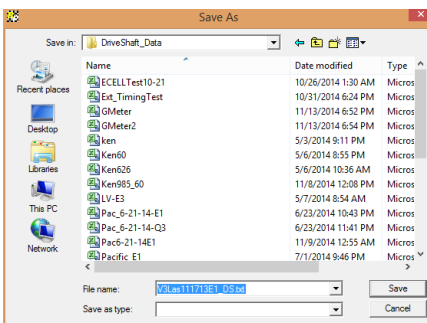

This window will open asking you to name the file and its location to be stored on your computer.

Since you will likely be doing this process and storing many driveshaft data files, it is highly suggested to **create a new file folder on your PC** to store them in. Create a location and name it so that

will be easy to remember and access frequently. In this case it is named **DriveShaft_Data**. Name your file something meaningful such as the data logger file name that was used.

Name the files you are saving something meaningful so you will know what it is at a later point in time when you import them into the Profiler application.



The name must be followed by a file extension of either

.csv or **.txt** or it will not export correctly. Either one will work. You **do not** need to select a “Save as type”.

Select **>Save**. If you saved it using a **.csv** extension, Windows Excel may open, or if you saved it with a **.txt** extension, Windows Notepad may open. Simply close whichever one opens.

Note: Any data logger that will output to a **.csv** or **.txt** file can be used; you are not limited to using a Racepak system. Most data logger systems have the ability to output those formats.

4.1.1 Importing Driveshaft Files

Start the Profiler software and open an existing **.pro** file or start one.

Select **>TC** button in the upper left corner of the Profiler screen.

Select either an existing **.pro** file or Select **>New** to start a new Profile.

NOTE: After you build your first Profile and run the car, the Profiler will record driveshaft data so in reality you should not need to import very many driveshaft curves from your logger.

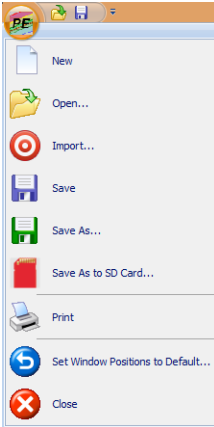

Select >**Import** to bring in the data logger driveshaft data file you exported.

Note: Once you make a run with the Profiler logging the data, you can use that data from the Run folder as well to create a new Profile.

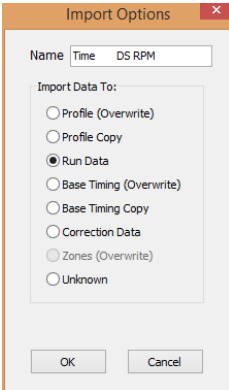

Enter a name you choose to use for this data. Again, make it a meaningful name. It does not carry the file name over from the imported file. Select >**Run Data**

Note: It's a good idea to name the data something meaningful such as the same name as the data logger file for example. Otherwise it's difficult to remember what was what once you start importing multiple files.

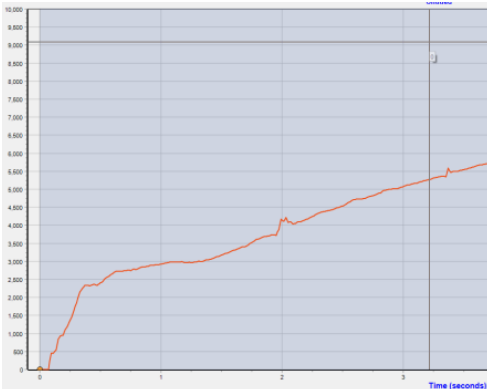

You now see the run you imported on the screen.

Other Import Options

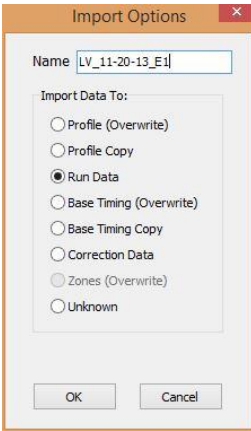

Profile (Overwrite) will overwrite whatever Profile is currently in the window.

Profile Copy will make a copy of a selected existing Profile and import it.

Base Timing (Overwrite) will import a saved timing Profile & overwrite the one on the screen.

Base Timing Copy will copy a selected existing timing Profile and import it.

Correction Data will import run data corrections from a pass that shows actual corrections that were made while running Profiler.

Unknown is a place holder for future use.

4.1.2 Building a Profile

Now that you have learned the basics of where everything is, let's build a sample Profile so you get the idea of the workflow. As with anything new, it will take a little practice until you get proficient.

Open the Profiler application and import a data logger driveshaft data file. You can import multiple files if you choose. One of the unique attributes of the software is you can import multiple driveshaft files and have the Profiler software create a Profile by averaging all of them together. In some cases this may be more realistic scenario to start with instead of only your fastest pass.

Now that you have the imported driveshaft curve or curves, it's time to put the Profiler to work. The following will get you started but will not touch on every single option available.



Select **>Create Profile** icon in the tool bar.

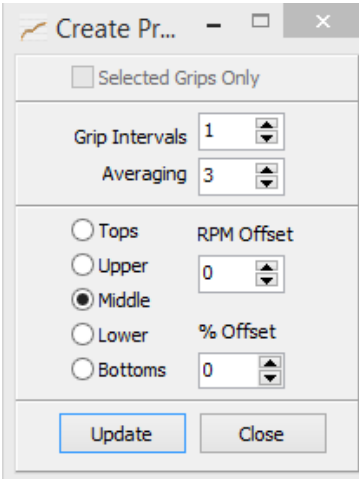

The “Create Profile” window has some options to choose from. The settings shown are a good starting point. The location options (Tops, Upper, etc.) are typically used if you have several runs open and you want the Profile to be created at the upper or lower range of those files as it averages them. You can try changing the settings to get a feel of how it works. **RPM Offset** will offset in 10 RPM increments. If you want to move more than 10, select “Cancel” on the Warning popup

menu until you get where you want, then select “Ok” and the adjusted Profile will be displayed. You can also **Offset** by a % value if you choose.

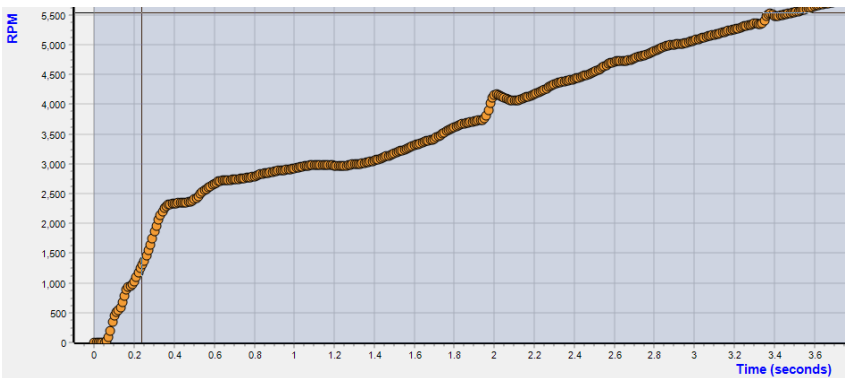

You can see there’s a dip in driveshaft speed in this example at .5 seconds. You might want to smooth that out a bit to have a smoother driveshaft RPM.

To do this, there are a couple of methods you can use. The first step is to select the “grips” in the range of the dip. Start at .3 seconds,

hold down the **Ctrl >left click** the mouse over the grip you want to select. The grip will now be red in color indicating it's selected.

Next, hold down the **Shift >left click** the mouse over one of the grips at .6 seconds. If all went well, all the grips between those two points should be red indicating the range of grips you selected.

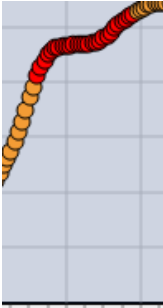

The section of grips you selected should look like the image on the left. If not, try again. Learning this selection method is critical in manipulating Profile curves.

At this point, you have a couple of choices of how to smooth this dip, one is manual, the other uses one of the powerful features of the Profiler which is **“Smoothing”**.

You can use the mouse to smooth by holding down the left mouse button on the bottom of the dip and moving the selected grips to wherever you choose. You will get a feel of how to move it once you try this method.

Allowing the software automatically do the smoothing works very nicely. When the grips are selected simply click on the smoothing icon, the more times you click, the smoother the line will be.

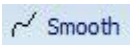

The Smoothing function is only available when a group of grips is selected, otherwise it's greyed out.



This result was achieved by clicking the Smoothing button about 20 times. If you want the curve smoother, click it more times or so. That area may require adjustment after a pass is made depending upon how much “correction” is required to clean up that area of the run. You can see where the original curve was as well as the

“smoothed” portion. The **Esc** key will de-select the grips.

If you toggle the Profile option in the legend box on the right side, it will turn off the grips and show you the driveshaft line that was created compared to the original one that was imported.

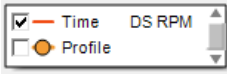

The Profiler software makes this easy. Toggle the grips back on by selecting the Profile in the legend box.



Toggle the grips back On by selecting the Profile in the legend box.

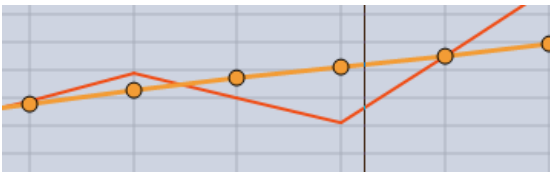

You can zoom in on a section of grips by holding down the right mouse button and drawing a

rectangular box around the area you wish to see. To return to the full view again, select the Zoom Max button in the tool bar.

Offsetting Selections of Grips

You may wish to offset a particular section of the driveshaft Profile up or down some RPM. You can select the range of grips you wish to adjust and manually move them as described earlier, however there’s another more automated way to do it.

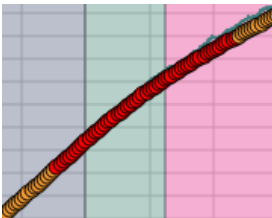

Select the range of grips you want to adjust.

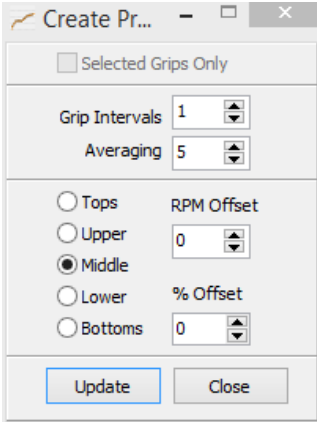

Select **>Create Profile** from the upper Chart Tools menu. The system will ask you if you wish to make a copy of the Profile before proceeding. It's usually a good idea to do this in case you want to revert back to the original. Notice that at the top of the popup window **"Selected Grips Only"** is now available.

You can either enter your desired offset in the **RPM Offset** box or use the up and down arrows which will show positive or negative values in 10 RPM increments.

You also have the option to use **% Offset**. Enter a % or use arrows for plus or minus .1% increments.

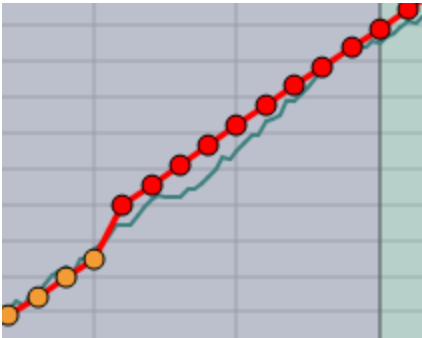

Here is the result of Offsetting the selected grips. You can then use the Smoothing function to blend this section in with the surrounding grips.

Next, let's add some **zones** which is a powerful feature of Profiler. As described earlier, multiple zones can be applied to a Profile, each with its own set of properties.

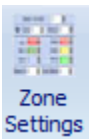

To view Zones, click on the **Zone Settings** icon in the tool bar.

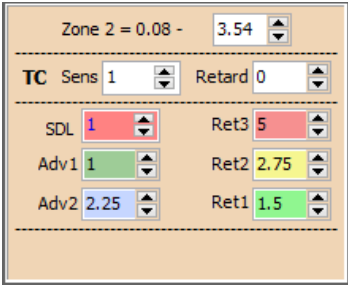

The **Zone** window will appear with a single zone with default settings. A description of the settings was described earlier in this User Guide. As you can see, Zone 2 is set from 0.08 (launch) to 3.54 seconds. You can manage the different parts of the run different than the rest of the run (maybe more aggressively for example). This is the power and flexibility of the Profiler platform.

To add another zone simply Select **>Add Zone** button.

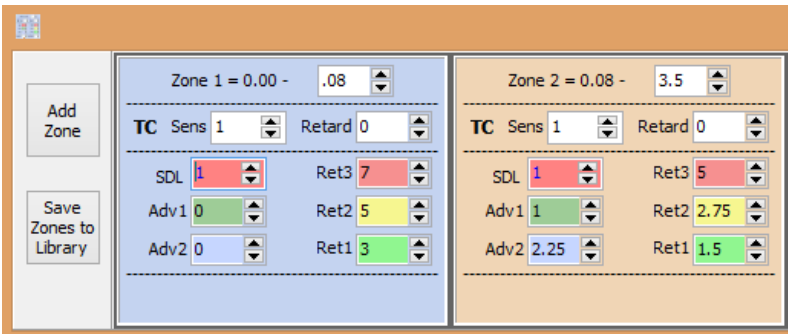

Notice each **zone** has its own color (which can be changed). Also notice that your Profile screen now has the associated zone colors dividing the time that you entered.



Next, Select **>Show Ranges** icon in the tool bar.

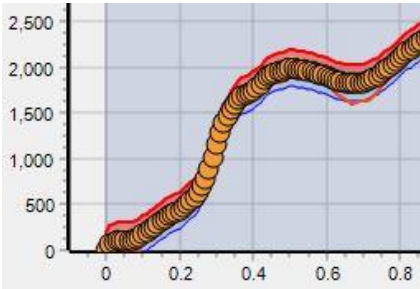

You now visually see the various RPM ranges for the Advance & Retard functions. If you forgot what these are, they are covered previously in this guide. The **Range** settings are in the **Correction Ranges** section of the tool bar.

Notice that the range colors correspond to the colors of the **Advance & Retard** settings in each **Zone**. If you choose to see the zones in more detail, zoom in on the Profile curve.

Try adjusting the **Correction Ranges** and see how the display changes accordingly. A larger range will make the zone color band wider.

Try changing the cursor settings in the tool bar and observe how it reacts as you move the mouse across the screen.

Reminder – In the current software, there is **no Undo or Back** function. Get into the habit of doing **File/Save** or **Make Copy of Profile** frequently or before you make changes so if you make a mistake or want to revert back you can.

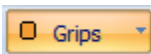

Try changing the size of the grips by selecting the pull-down arrow by the Grips icon in the tool bar.

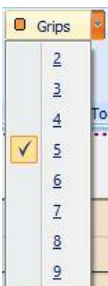

The higher the number you select, the bigger the grips will appear on the screen. This gives you options as to what size you feel most comfortable working with.

4.2 Timing Relationships

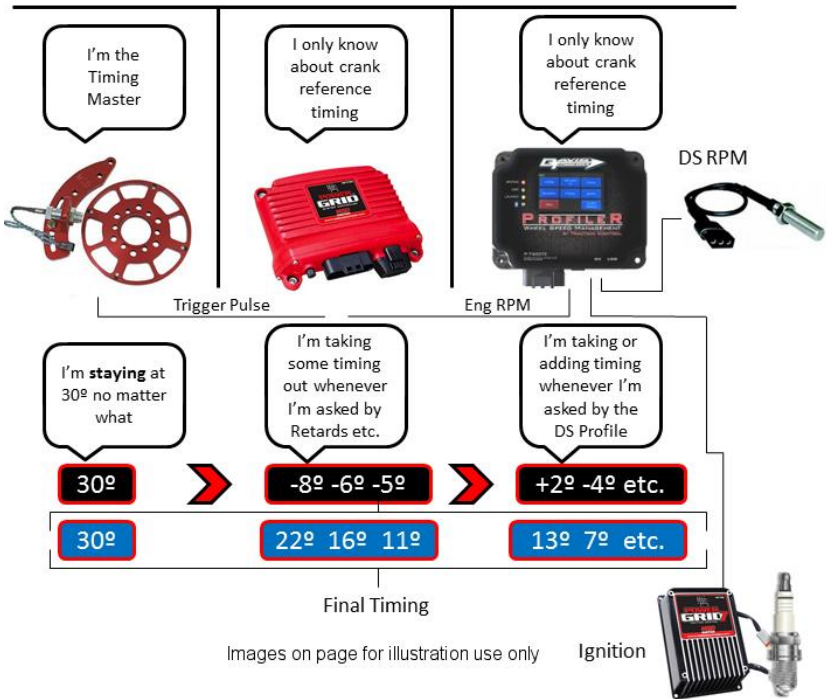

It is critical for you to understand the timing relationship between the various ignition components. With nitrous this is crucial when defining your Profiles as you will be using Step Retards at various points during a run as well as timing advance and retard with the Profiler. The Profiler has no idea of what the ignition controller is doing. All it knows is if the driveshaft speed is above or below our plotted Profile curve it's going to advance or retard timing.

NOTE: In this case if you put your timing light on the balancer with the **Profiler OFF**, you should see 30° timing. With it ON and you

have your **Static Timing** set to **26°**, you should see **26°** on the balancer. Again, in this scenario, when the Profiler is powered ON, it's pulling 4° of timing from the crank trigger setting.

This is what gives you 4° of timing window you can advance during a run.

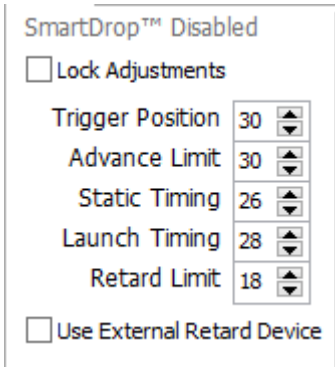

Again, in the scenario above, this will give up to 4° of timing Advance and up to 8° of timing Retard to work with.

It's easy to get yourself very confused and easy to chase your tail as to where timing is really at. If for some reason you decide to run your car with the Profiler turned OFF, your crank timing is going to be different than where it is with the Profiler turned ON.

This one of the reasons the Profiler is wired so whenever the ignition is on, the Profiler is on. Start the car and with a timing light, your timing should equal your Static Timing setting.

With nitrous applications you also have to take into consideration all the retards you have programmed into your ignition box as well as the Profiler settings.

As mentioned previously, you must understand this clearly to avoid possible timing issues that result in engine damage.

Module 5: Profiler Tips

The Davis Technologies Profiler is a powerful tool, not a miracle worker. As with many products, it still requires input from the user to work from. Here are some tips that might help get you going quicker and faster sooner.

- Base your initial Profile on some of your best passes. Import several logger driveshaft data runs and let the Profiler average them to create your first profile as a starting point.
- Be realistic with your base timing numbers. The Profiler can add timing as well as retard it. Keep the timing numbers realistic, especially with nitrous cars, to keep the intake on and pistons in one piece. (upper & lower timing limits)
- Use the **Zones** to build different parameters into different areas of the run. From 2-3 seconds into a run, you may not need the timing corrections that you use early in the run.
- You will find in most cases the **Smart Drop™** is your friend. Once your upper timing correction range (Red) reaches 76%, the Smart Drop™ function becomes active if it was enabled in a Zone. Depending upon what level it is set at, it will drop a random cylinder(s) and never the same one twice. With a nitrous engine a setting of **1** is recommended which has proven very effective. The higher the setting the more cylinders it will drop.
- **Insure NO grips are below zero!** If the Profiler sees a grip below zero, the Profile will not upload from your PC to the Profiler. If you keep getting error messages or file upload issues, go back and check your Profile near the zero time point. Zoom in the view on the first few Grips to check.
- The width of your correction ranges will affect how aggressive the corrections will happen. The wider the correction range, the less aggressive it will be and the

narrow the ranges are, the more aggressive it will be. If you double your degrees of timing correction and also double your range, it will react with the same aggressiveness. The default ranges are a good starting point.



- Once you fine tune your system, you will likely narrow the correction ranges down.
- When you import run files, it is **important** that you name them something meaningful or you will quickly find that it's impossible to make heads or tails of what each file is. There are driveshaft runs, base timing files, corrections files, zone files, and Profiles that all are saved into the Profiler libraries. Make copies of the files and name them something like "XXX As Run Q3" for instance or use the same naming scheme as your data logger files so they can all be related to each other.

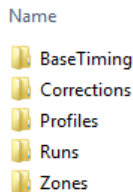

- The Profiler software does not currently have a "Back" or "Undo" feature, so it is suggested to "Save" and "Save" often to insure you don't lose your settings.
- After downloading the Corrections data, as with any run data, pay attention to what it's telling you. If the Profiler made a timing advance and the car responded favorably, you will likely want to adjust your Profile curve up a little in that area. If it rattled the tire or upset the car, you may want to lower it a little as maybe that's all the tire or track will take. In the case below, the Profile line is above the actual run. If the car will only run as shown, you would

probably want to adjust the Profile down since it the car just will not run faster even with timing being added.

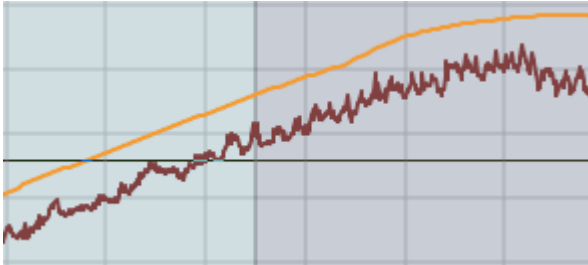

- If the corrections data show consistently that a lot of correction is required in one area, you may have to adjust your base timing curve (Absolute Timing) in order to minimize the amount of corrections. In the example below, you can see that the Profiler added timing from .2 to .8 in the run. In this case, you may want to adjust the base timing curve up in that area to minimize corrections.

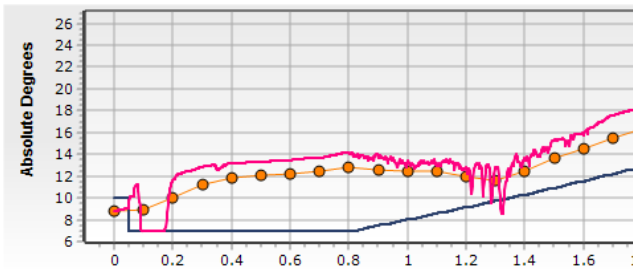

- When altering the Timing profile curve, you may notice that sometimes the grips become further apart, leaving noticeable gaps in between them. It's advisable to add grips in those areas. Follow the procedure that is documented in this User Guide to do this. Increasing the number of grips will increase the resolution of your data the Profiler will follow.
- Study your data carefully, the Profiler will show you what your car wants. Once you fine tune your Profiles, you will find your runs are very repeatable under similar track and weather conditions. Typically only slight adjustments are

required from that point on unless something drastically changes.

- The Profiler has the **Events** functions for controlling other devices in your car such as shifters, fuel leanouts, water injection, trans-brake etc. Take advantage of these to save money, space, & weight of multiple controllers. A trans-brake connection is especially nice as it eliminates basically any delay in the release time compared to the typically method of using a relay type circuit.
- The Bluetooth feature for uploading and downloading files is available, however be aware data transfer is a little slower compared to using a USB cable.
- On the bottom edge of the Profiler case, there is a jack next to the USB port. This is for a future option of plugging in a small LCD touchscreen so the driver or crew can make easy option changes. A future enhancement will allow storing multiple Profiles in memory so it will be possible to select another Profile without uploading a new one from a PC device.
- Don't forget about the small recessed LED on the bottom edge of the Profiler. Use this as a diagnostic tool to see if the box is seeing crank trigger pulses. It should pulse every crank trigger signal.
- Air shifters such as the Biondo or Precision Performance Products use solenoids that have very little current draw (typically 400mA or so) which lends itself to using the Low Power Event options **LP7** or **LP8** that can support up to 750mA Neg . Check with your shifter vendor to see how much current their solenoids draw. If it's more than 750mA you can always use one of the High Power Event circuits.
- The micro USB ports can sometimes get damaged if you aren't somewhat careful plugging them in and out but accidents can happen when you are in a hurry. To eliminate the possibly of damaging them you can procure panel mount USB pass-through modules for less than \$10 like the ones in the picture below. These are USB A female on each end so the idea is to use a short USB pigtail that is Micro Male to A Male to go in-between your Profiler (and

Grid) if you have one and one end of the panel mounted USB pass-through plug. This eliminates having to ever plug or unplug the Micro USB port in the box(es). You then use a standard USB A Male to USB A Male cable from your PC to the panel mount.

These can be sourced from DataPro www.datapro.net with part number CCP-USB2 for \$7.95 ea.

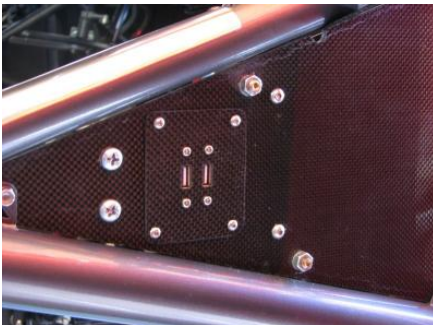

- When you setup your Chart Scale parameters for Time and RPM, set time for about 1 second longer than your typical pass. If you only run 1/8 mile for instance and set the Time parameter accordingly, it will shorten your file transfer times considerably as it eliminates unnecessary data.
- It is recommended you make **Zone 1** from 0 to approximately .08 seconds with minimal timing corrections. It takes a revolution or two of the driveshaft to gather data to use to follow the Profile and make corrections.

- Increase capacity of your Profiler Low Power Event controls or other car circuits by adding the Davis Technologies **HSD4** solid state relay module. This will provide you with 4 50 amp capacity outputs that can be activated by Ground triggers or + (Pos) triggers on 2 circuits. It's only 3¼"L x 1¼"H x 1¼"W, very compact and lightweight.

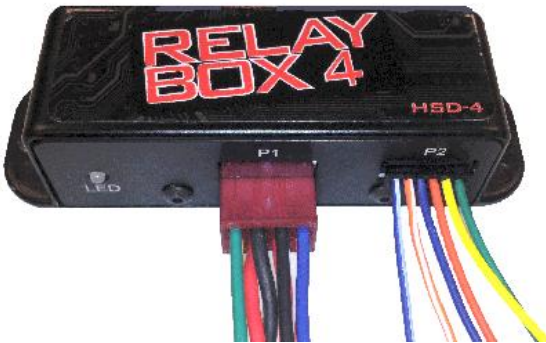

- Experience has shown that sometimes adjusting the profile curve to try to get the minimum number of corrections doesn't always yield quicker runs. Sometimes it is actually better just letting the Profiler do its thing, and make all the corrections it needs to. The corrections log may not be the smoothest looking, but the ET slip says in many cases it may be quicker.
- Try the "Ramp In" feature. This lets you control how fast timing will be ramped back in after a correction. The result is an overall smoother timing control. See the Ramp In section previously covered in this guide on page 4-12.

Appendix 1 License & SD Card Information

SD Card is Lost or Damaged?

If you should happen to lose your card, break it, or for whatever reason no longer works, don't panic, your Profiler will work fine for a period of time to get you through a race or two. Call Davis Technologies for a replacement card.

Backup License File

When your software is installed, you will see a **License** folder in the same directory as your other Profiler files. In the folder is a **LICENSE.BIN** file. This is a copy of your encrypted licensing file that is locked to you and your Profiler box serial number.

USB Cable Lost or USB Connector Damaged?

If you should forget your USB cable, accidentally damage the cord or box connector, again don't panic, you can still race and transfer profiles, download, etc. **To create an "emergency" file, use the File > Save As to SD Card function.**



It will ask you to name the file. It will be saved as a .emr file and stored in the Profiler Libraries >Profiles folder.

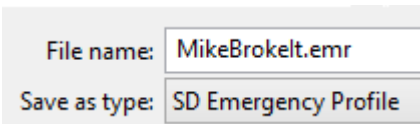







Remove the card from the Profiler housing by gently pushing it in to release it and pull it out. Insert the card into the Adapter supplied in the Profiler kit or if you have a SD card reader. Connect or insert into your PC. Open the Removable Disk with Windows File Explorer to see the files on the card.

DO NOT delete your License file! But, if you accidentally do, copy the backup LICENSE.BIN file onto this card.



Name

You will see three file types on the card:

-  01052027.PRR
 -  01072250.PRR
 -  LICENSE.BIN
 -  PROFILE3.PRB
 -  PROFILE4.PRB
 -  PROFILE5.PRB
 -  PROFILE6.PRB
- .PRR files are run data files
 - **LICENSE.BIN** is your Profiler License file
 - .PRB files are Profiles

On your PC, go to the **Profiler Library >Profiles** and select the .emr file you just created.

Copy that .emr file to your Profiler SD card which will load the Profile. Put the SD card back into your Profiler and it will recognize the emergency file you created.

Appendix 2 Windows XP COM Driver Install

To verify if the Davis COM Port was automatically installed during the software installation, perform the following checks below.

NOTE: You MUST have Windows XP Service Pack 3 installed or the driver will NOT load.

To check if it is loaded or not, follow this process:

Select >**Start**

Select >**My Computer**

Select >**View System Information**

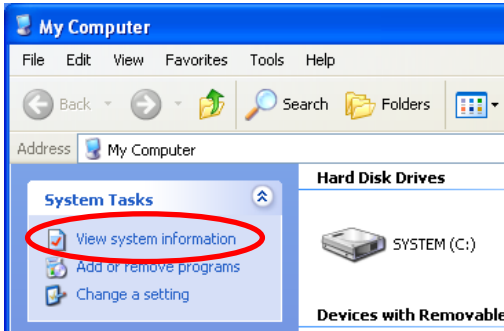

If you don't have Service Pack 3 installed, the driver **will not work**.

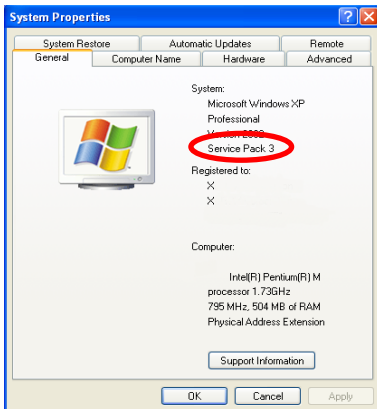

Go to the Microsoft web site and download Windows XP Service Pack 3. Windows XP is not supported any longer but the driver is still available.

1. **Connect** the USB cable from your PC to the Profiler.
2. Select **>Computer**
3. Select **>View system information**
4. Select **>Hardware**
5. Select **>Device Manager**
6. Select **>Ports**
7. Click on the + sign to expand the Ports levels

You should see the Davis COM Port (COM2) or whatever port it found free.

If there is a yellow exclamation point next to the driver name, Right Mouse Click **>Update Driver**.

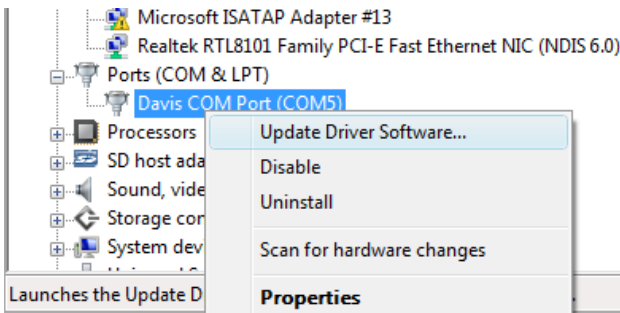

If there is nothing indicating something is incorrect, it has loaded correctly and your driver should be operating normally. **Remember the COM number as you will need to set that in the Profiler.**

If the driver looks Ok, Stop here, otherwise perform the steps below.

If it **did not** load correctly, **Right Mouse Click** on the Port

You will see a pop up box op, Select **>Update Driver**

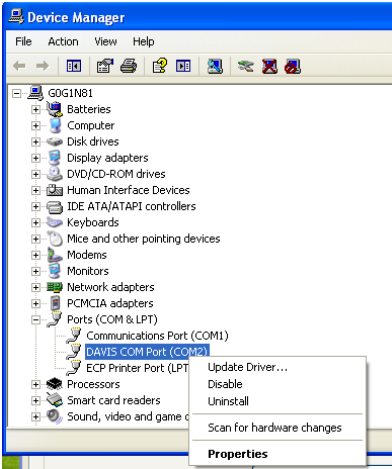

A new window will open asking where you want to source the driver from.

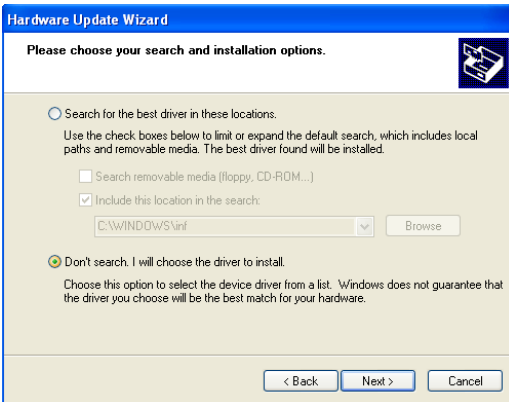

Select the option Don't search, I will choose the driver to install.

Select **>Next**

Another window will open showing you a list of drivers available.

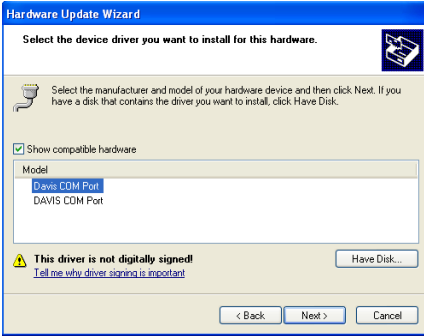

Select > **Davis COM Port**

Select >**Next**

You will likely get a Compatibility window open.



Select >**Continue Anyway**

Once the driver has installed successfully you should see the window below.

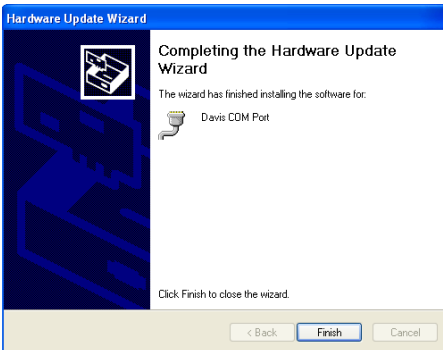

Select >**Finish**

Appendix 3 Windows 7 COM Driver Install

To verify if the **Davis COM Port** was automatically installed during the software installation, perform the following checks below.

1. **Connect the Profiler to your PC** via the supplied USB cable. The splash screen should light up signifying its got power.
2. On your PC, Select **>Computer > System Properties**



3. Select **>Device Manager**

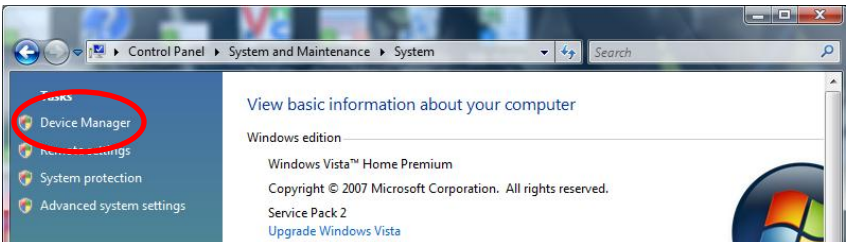

4. Look down the list of devices and you should see **Ports**. If you see one labeled **Davis COM Port (COMx)**, the driver has installed correctly and has loaded.

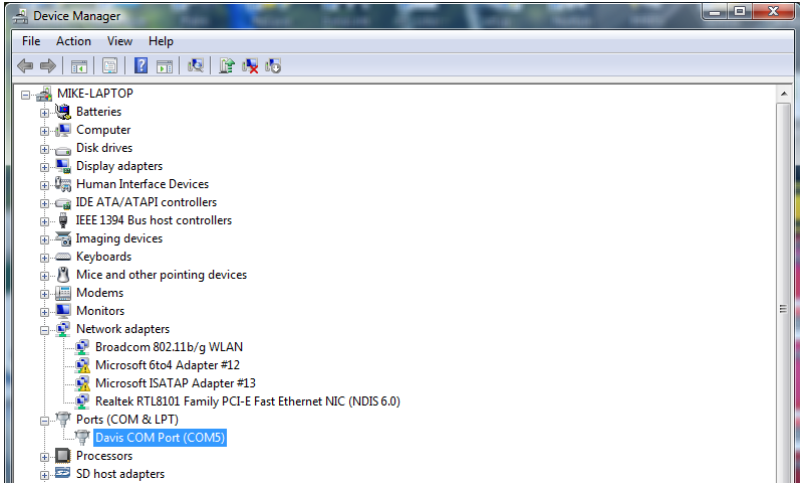

5. If you see an **exclamation point with a yellow background** next to the port, it hasn't loaded correctly. Follow one of the two options described next.
6. Right mouse Click on the port. You will see a pop-up window with an option "**Update Driver Software...**"

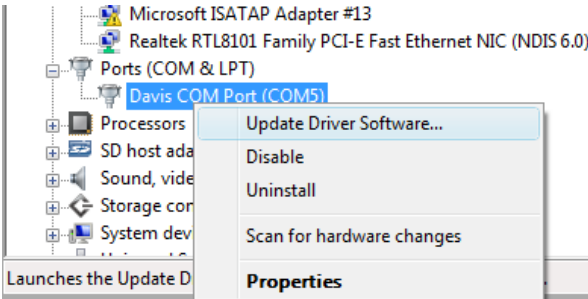

7. Select **>Update Driver Software**

8. Select >**Browse my computer for driver software**

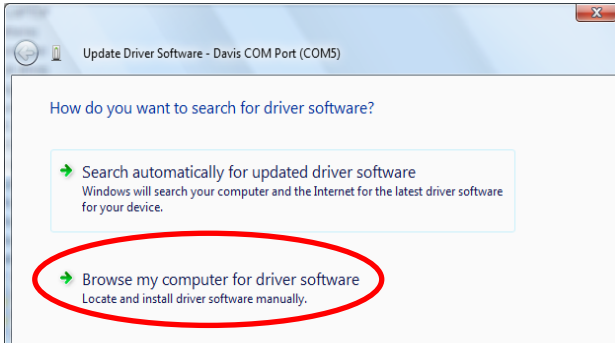

9. You will see the window below. Enter > **C:\Windows\inf** and Click >**Next**

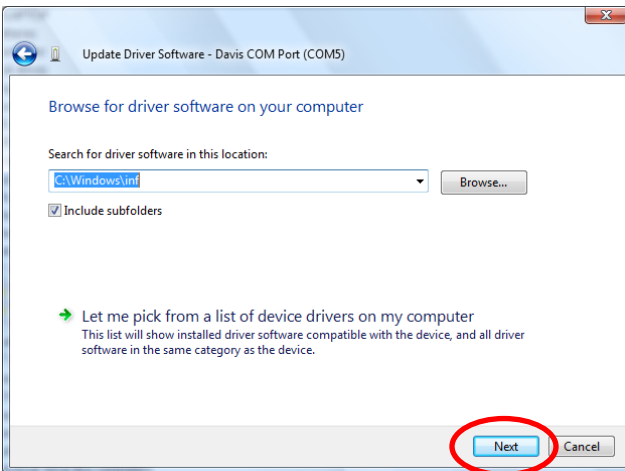

If the driver is in the directory, it should load automatically and tell you the DAVIS COM Port is installed and loaded.

Alternative Method

1. An alternative method is to use Windows Explorer and go to the **C:\Windows\inf** directory and scroll to the file **DAVIS_TECH_COM**

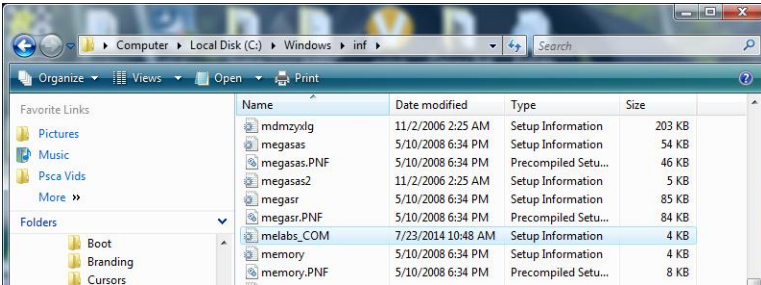

2. Right mouse Click and then Click **>Install**
3. You should get a confirmation that the driver installed and loaded.
4. Once the driver is verified it's installed and loaded, it's a good idea to go to the **Device Manager**, find the **Davis COM Port** and check the settings. The **default** COM port settings will work with the Profiler.

Right Click on the **Davis COM Port** name to get the **Properties** menu.

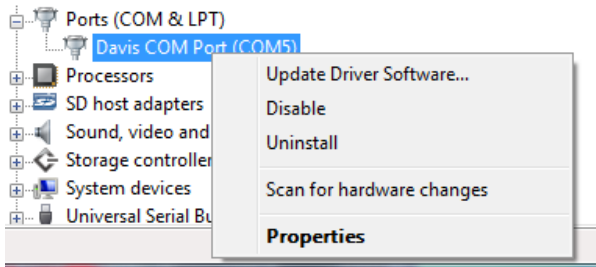

5. Select >”Port Settings”

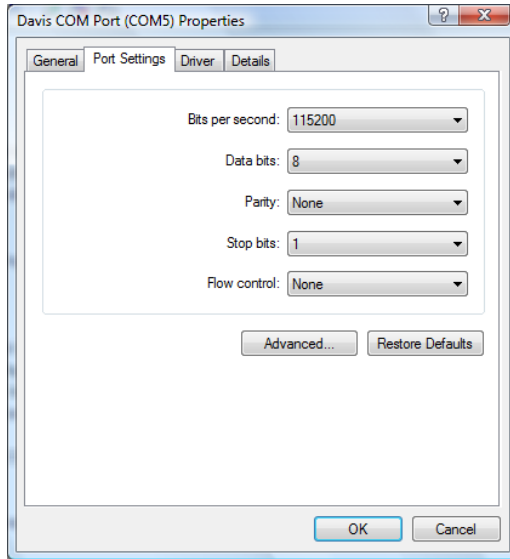

Alternative Method 2

When your Profiler software was installed, one of the folders included a Drivers folder that has the DAVIS_TECH_COM driver.

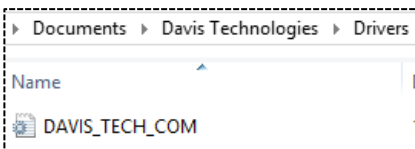
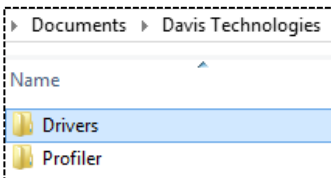

For the next step, you must have your Profiler connected to your PC with the USB cable.

In the Device Manager window, Right mouse click on ‘Ports’ devices.

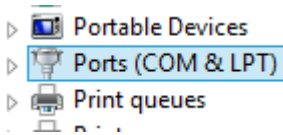

Select ‘Scan for hardware changes’.

It should find your Profiler connected and display the window below.

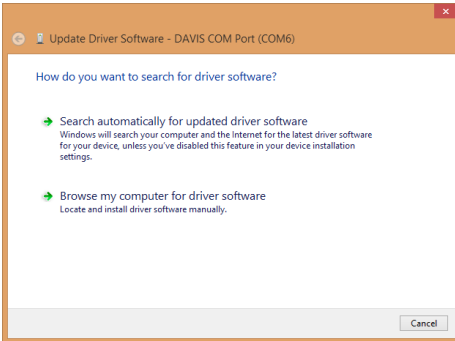

Select ‘Browse my computer for driver software’

When the window opens enter the following address in the Search location box:

C:\Users*(your user name)*\Documents\Davis Technologies\Drivers

Select >**Browse**

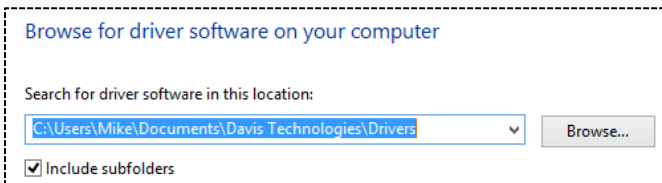

The driver should install.

Appendix 4 Windows 8 COM Port Install

At this point connect your Profiler to the PC with the USB cable.

1. Hold down the Windows key on your keyboard and press the letter C to open the Charm menu, then click the gear icon (Settings)



2. Click >Change PC Settings

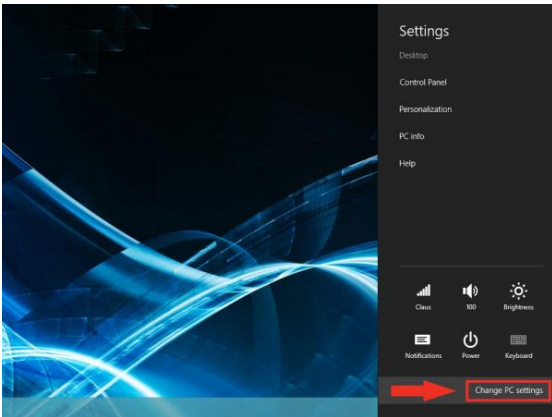

3. Click >**General**
4. Under Advanced Startup, Click >**Restart Now**

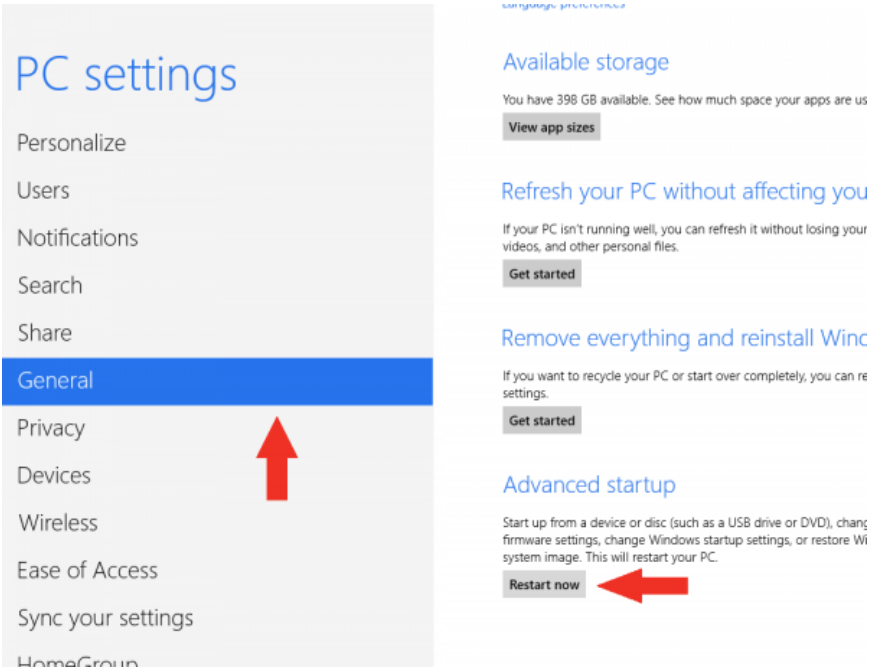

5. After restarting, Click >**Troubleshoot**

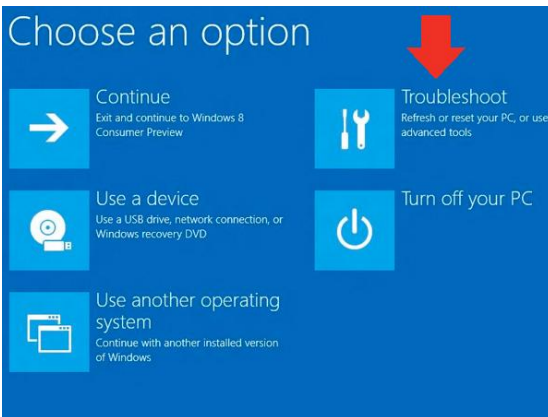

6. Click >**Advanced Options**

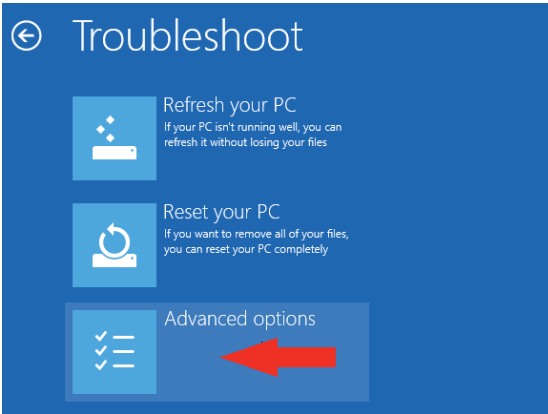

7. Click >**Windows Startup Settings**

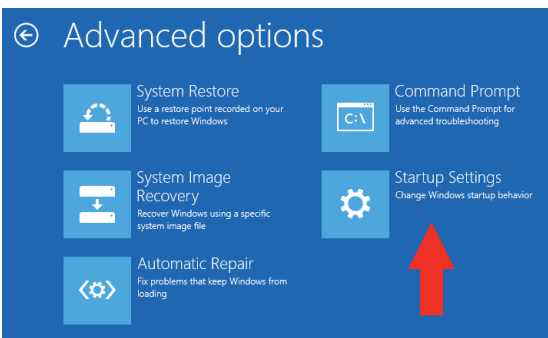

8. Click >Restart

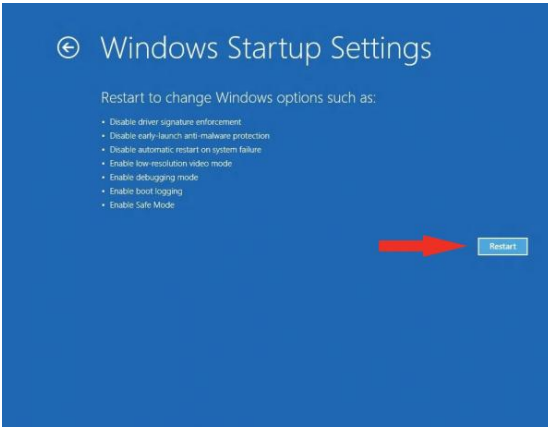

9. After restarting your computer a second time, choose **Disable driver signature enforcement** from the list by typing the number **7** on your keyboard.

10. **NOTE:** *The latest versions of Profiler Editor now have a Windows signed driver so you may NOT have to disable signed drivers to complete a successful installation.*

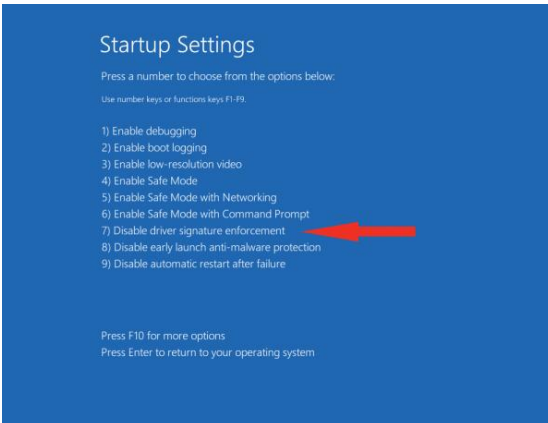

Your computer will restart automatically.

- After restarting, you will be able to install the Davis_COM driver normally; however Windows will display a warning message. When the warning appears, Click **>Install this driver software anyway**.

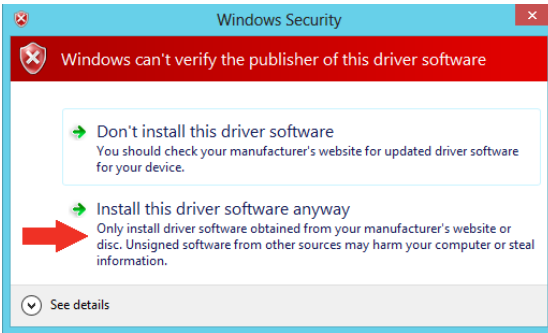

NOTE: The next time you restart your computer, driver signature enforcement will be in effect again. You will have to repeat this process for any new drivers.

Appendix 5 Windows 8.1 COM Port Install

At this point **connect your Profiler to the PC with the USB cable.**

NOTE: The latest versions of Profiler Editor now have a Windows signed driver so you may NOT have to disable signed drivers to complete a successful installation.

1. Press the **Power** button at the Windows login screen or in the **Settings** charm. Then press and hold the **SHIFT** key on your keyboard and click **Restart**.

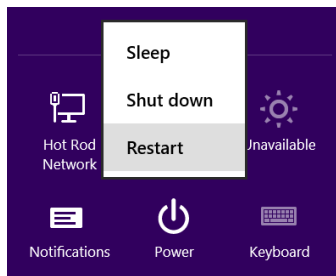

2. Windows will then ask you to choose an option. Select **>Troubleshoot**

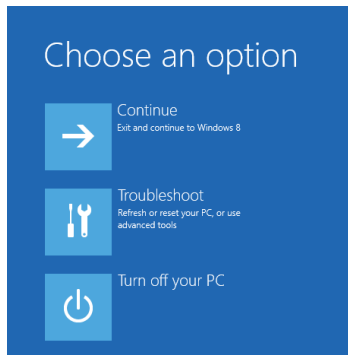

3. In the Troubleshoot screen Select >**Advanced options**



4. In the Advanced options screen Select >**Startup Settings**

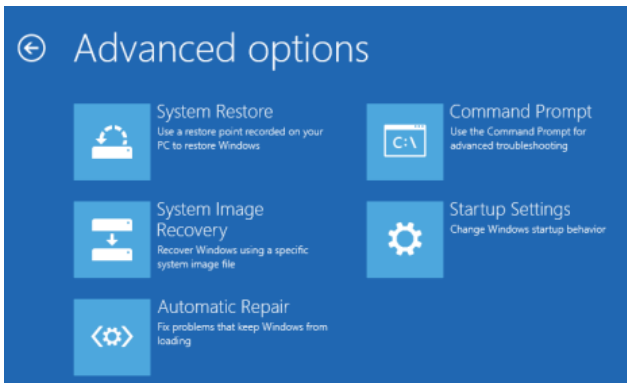

5. You are informed that you are about to restart in order to change several Windows options, including **Disable driver signature enforcement**. Select >**Restart**

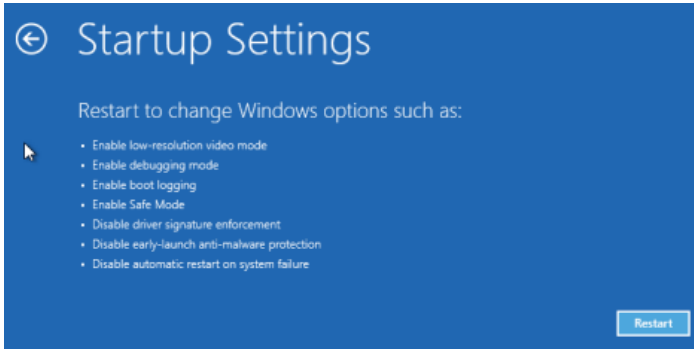

6. Your computer restarts again and displays nine startup settings, including **Disable driver signature enforcement**.

As the menu says, use number keys or function keys F1-F9. **Select option 7**

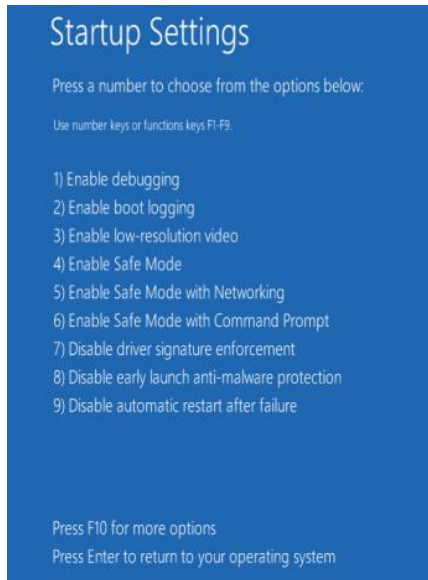

7. Your PC will reboot to Windows

- Use Windows File Explorer and navigate to the **This PC** directory

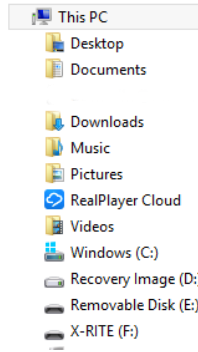

- At the top of the “This PC” screen Select **>System properties**

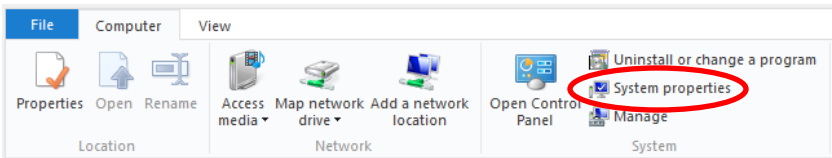

- You should see the screen below. Select **>Device Manager**

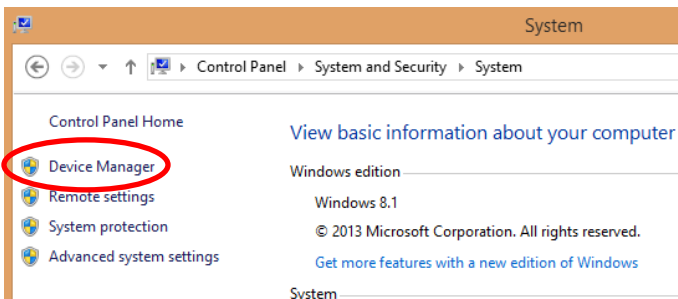

- On the Devices screen, under Ports, you should see **Davis COM Port**

Right mouse click on the name and Select **>Update Driver Software**

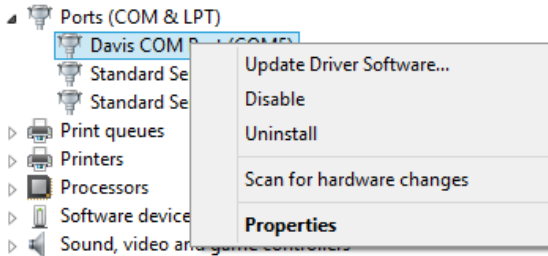

You will get a Windows Security pop-up window

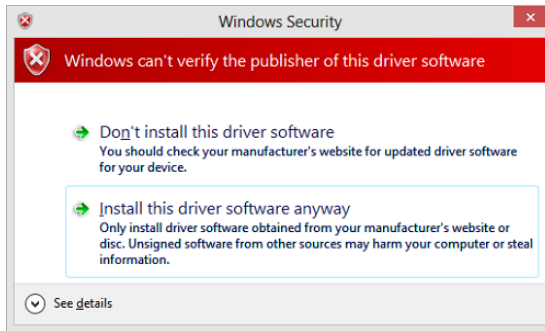

- Select **>Install this driver software anyway**
- The driver should load ending with a confirmation message that it successfully installed and loaded.

Alternative Method of Loading Driver

Once the Driver Signature Enforcement has been disabled, there is another alternative method of installing the driver.

1. Use Windows Explorer and navigate to the **C:\Windows\inf** directory.
2. Scroll down to the file **DAVIS_TECH_COM**
3. Right mouse click on the name
4. Select **>Install**
5. If you get the Windows Security Warning, Select **>Install this driver anyway**
6. The driver should load ending with a confirmation message that it successfully installed and loaded.

Alternative Method 2 of Loading Driver

When your Profiler software was installed, one of the folders included a Drivers folder that has the DAVIS_TECH_COM driver.

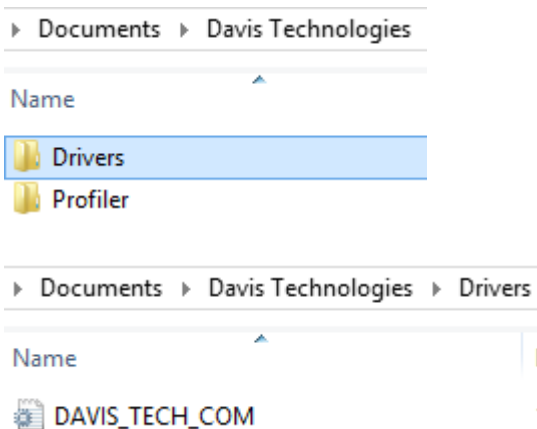

For the next step, you must have your Profiler connected to your PC with the USB cable.

In the Device Manager window, Right mouse click on 'Ports' devices.

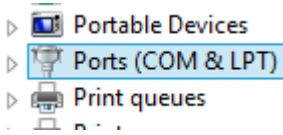

Select 'Scan for hardware changes'.

It should find your Profiler connected and display the window below.

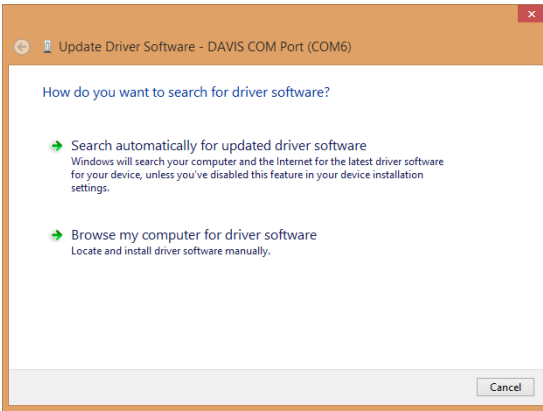

Select 'Browse my computer for driver software'

When the window opens enter the following address in the Search location box:

C:\Users*(your user name)*\Documents\Davis Technologies\Drivers

Select >**Browse**

The driver should install.

Appendix 6 Integration With Racepak V300

The older V300 Racepak product and some other data loggers have a 2 wire input plug for the driveshaft sensor wiring. The V300 can normally only accept a 4 pulse input signal from the driveshaft sensor, however if you use a Hall Effect 3 wire sensor, it will handle 8 pulses. Because the Racepak harness is only two wires, there is no power wire for the sensor so you will have to run some wire to the sensor. Plugs and pins are included in the kit so a little wire is all you should need.

Plug the 3 pin “leg” end of the “Y” harness into your driveshaft sensor labeled ① in the photo below. **Wire colors may vary but pin outs are consistent.**

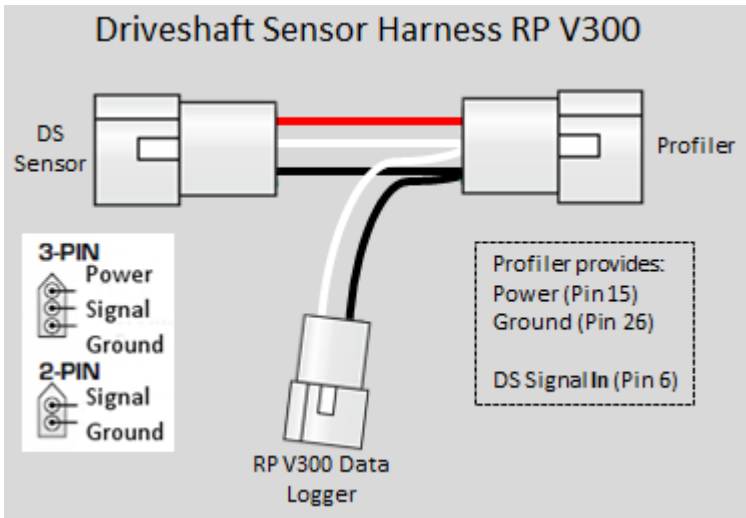

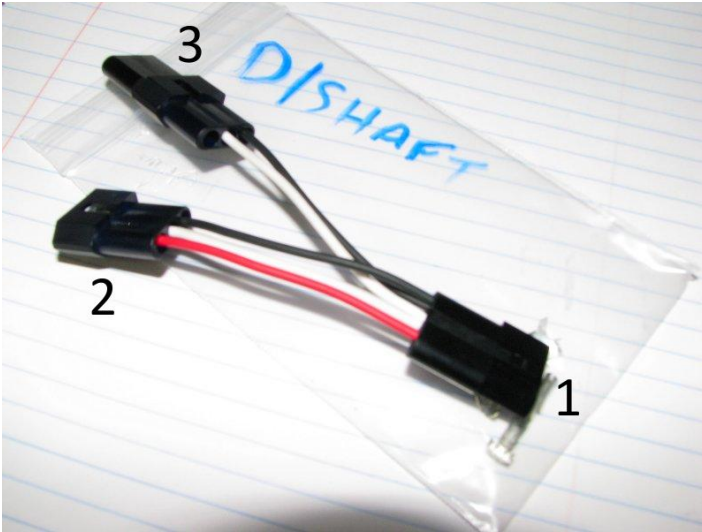

You should already have the 3 pin harness at the rear of the car from the Racepak or other data logger. Plug that into the other 3 pin connector in the supplied harness. ②

Run a White wire from the Profiler pin 6 to the Signal pin in connector ③ shown above. This is the 2 pin connector.

To make up the 3 wire harness you can get power (pin 15), ground (pin 26), and signal (white wire pin 6) that goes between the driveshaft sensor and the Profiler. Use the supplied plug and pins to make up the harness and plug into end ② shown above.

Your two pin Racepak sensor harness should already be at the rear of the car. You will plug that into the 2 pin leg of the “Y” harness labeled ③ above.

Appendix 7 Integration With Racepak V300SD

The Racepak V300SD and some other data loggers have a 3 wire plug connection for the driveshaft sensor.

Plug the 3 pin “leg” end of the “Y” harness into your driveshaft sensor labeled ① in the photo below.

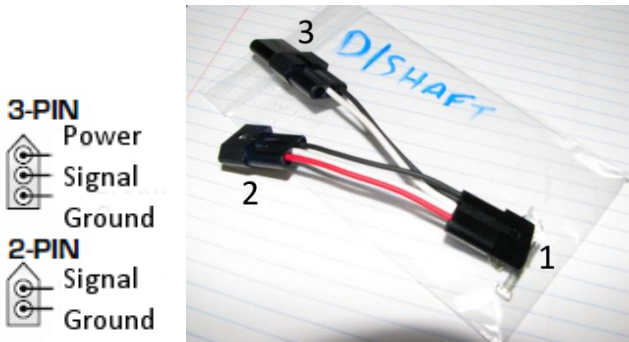

You should already have the 3 pin harness at the rear of the car from the Racepak or other data logger. Plug that into the other 3 pin connector in the supplied harness. ②

Run a White wire from the Profiler pin 6 to the Signal pin in connector ③ shown above. This is the 2 pin connector.

Wire colors may vary but pin outs are consistent.



Appendix 8 Touch Screen Menu Trees

Touch screen menu trees are here for reference. Navigate the menus to get familiar with them. You will need to set values for the features you choose to use. The basic installation requires minimal settings.

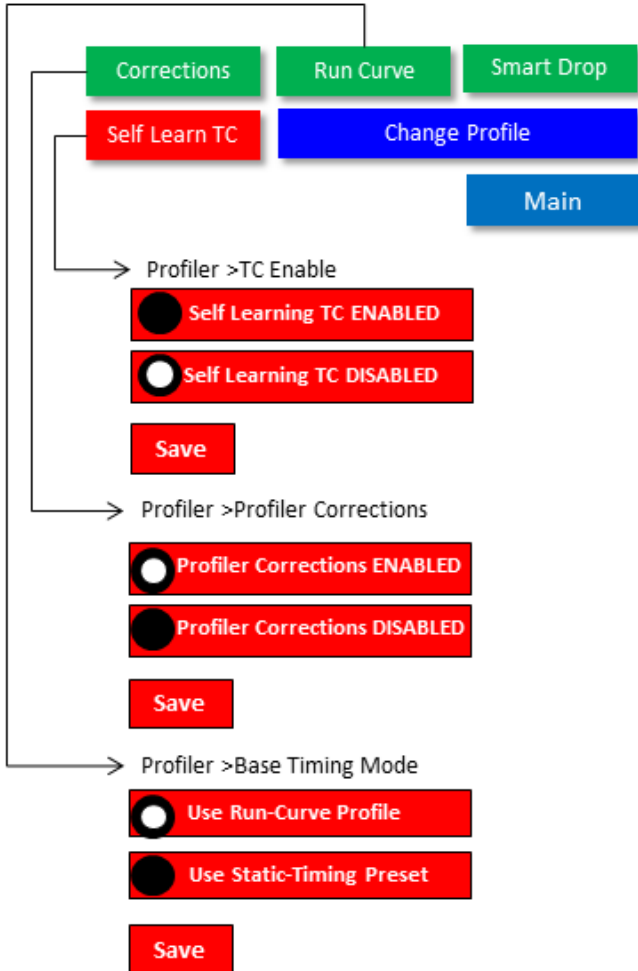

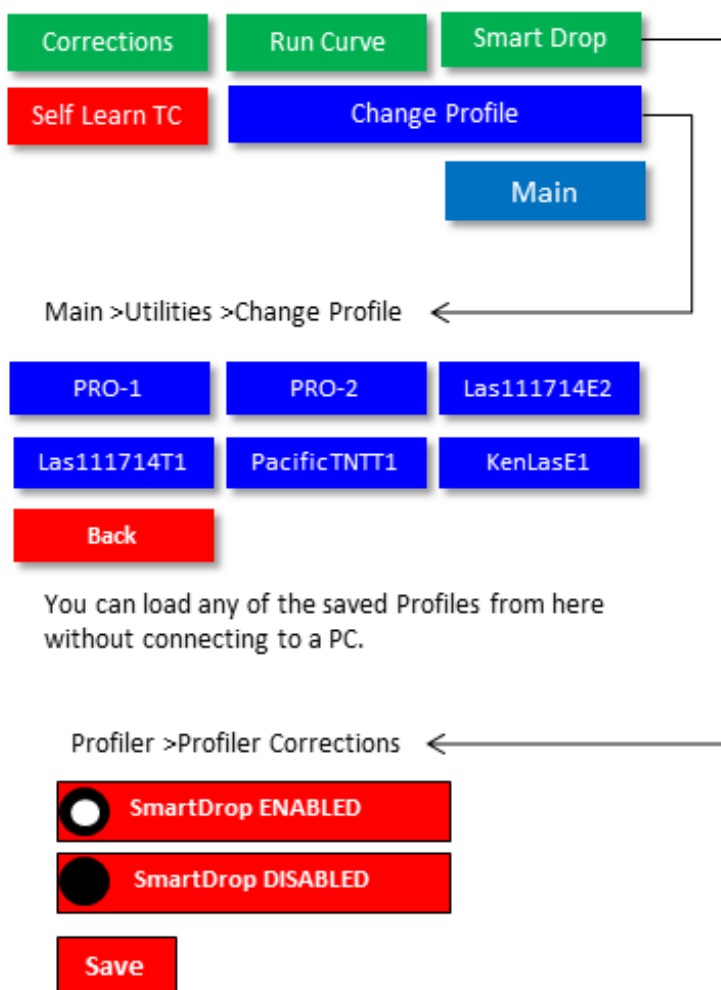

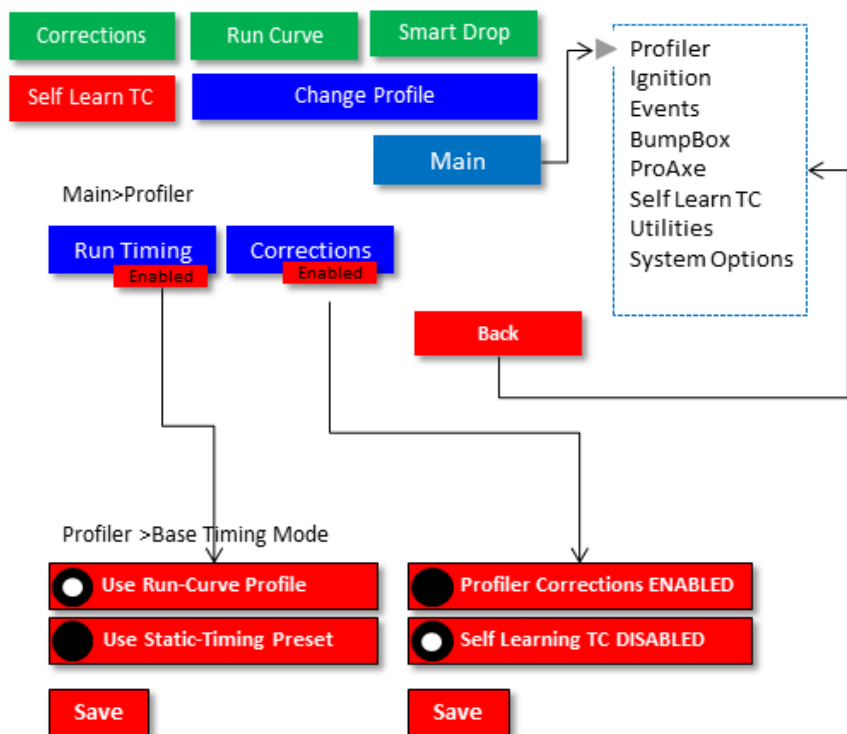

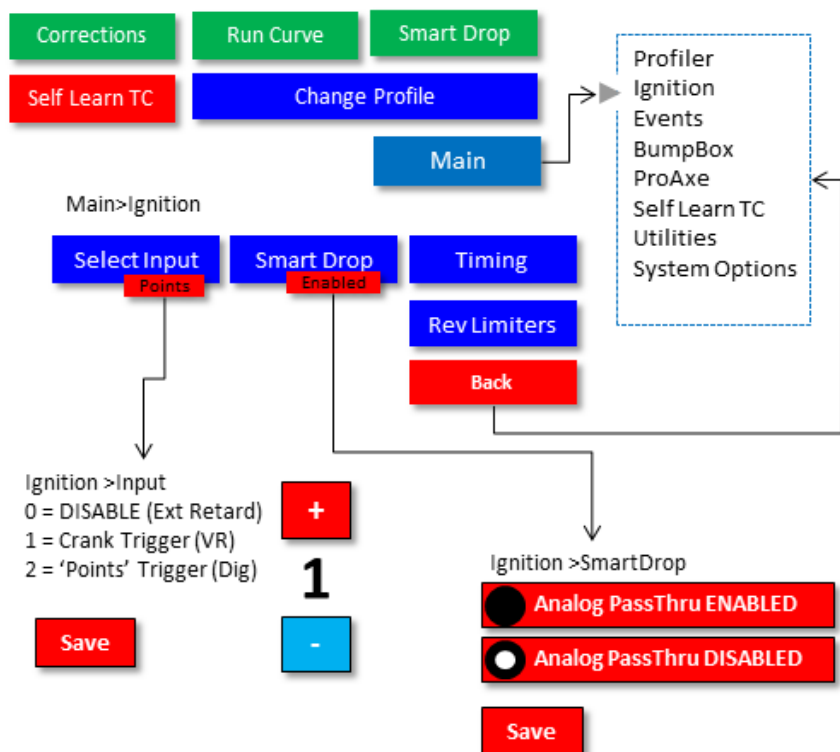

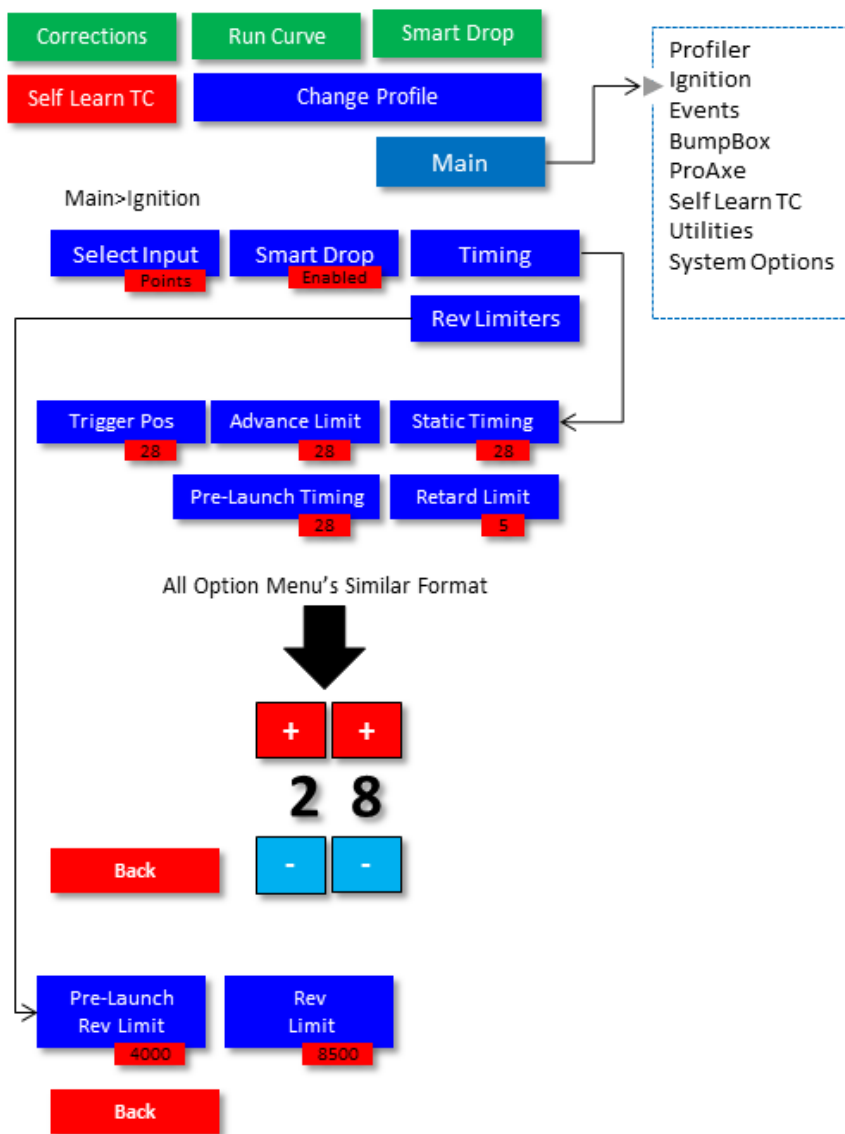



Refer to Section 4.0.6 for detailed information on each Event Parameter setting.

- HP Events can be pulsed (Duty Cycle) and ramped while LP Events cannot.
- HP Events are rated at 30A capacity.
- LP Events are rated at 750mA capacity.

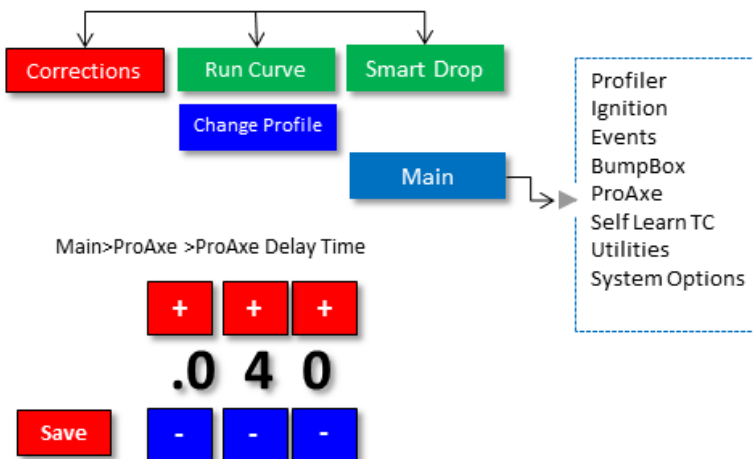
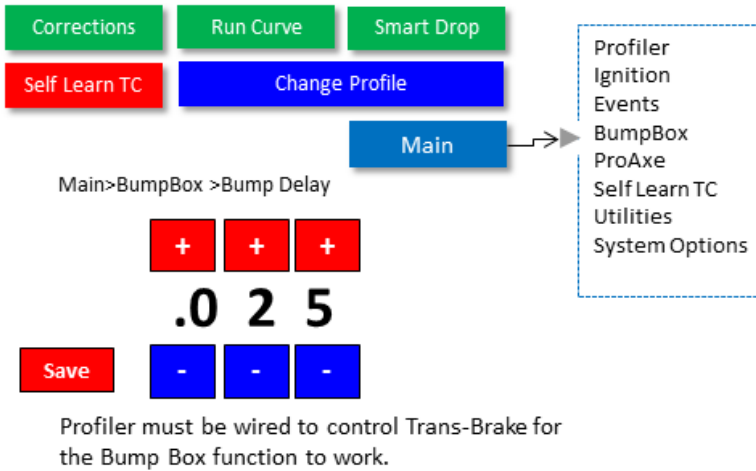

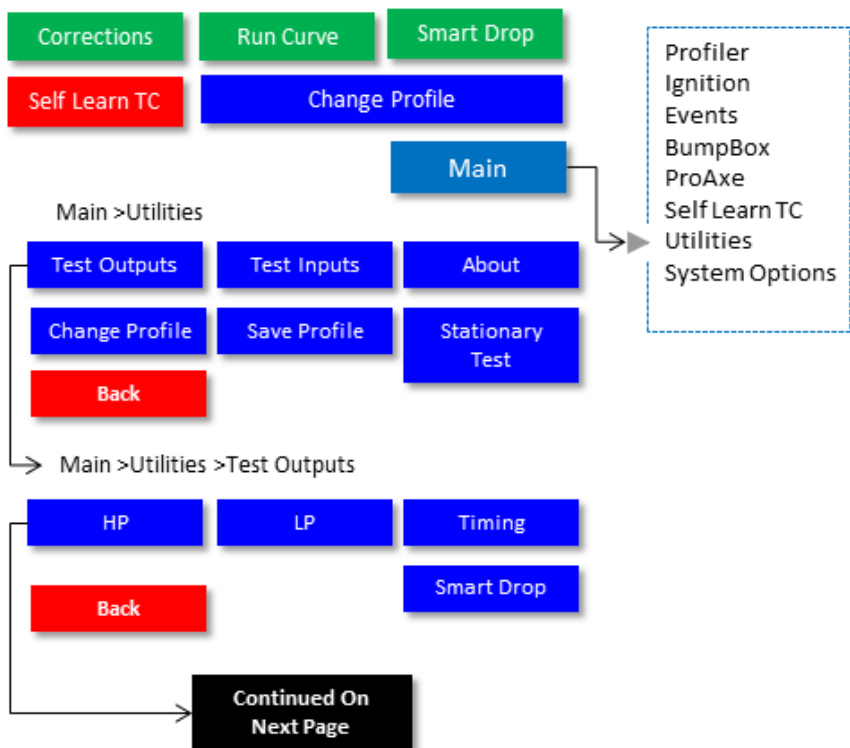
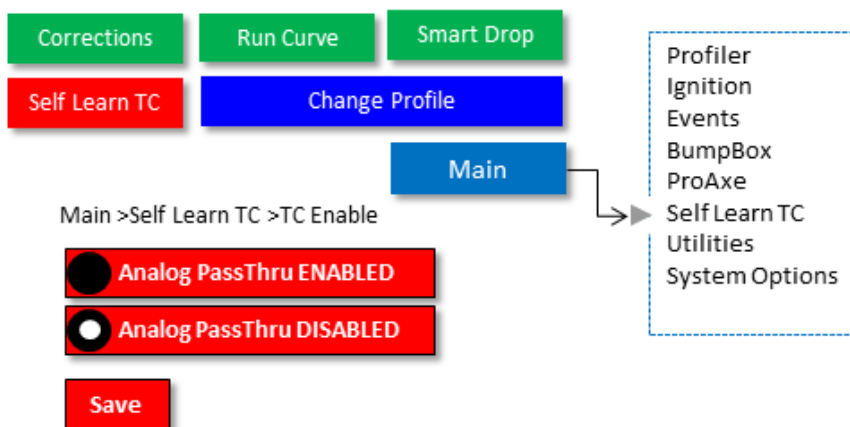

Main >Utilities >Test Outputs



→ Main >Utilities >Test Outputs >HP

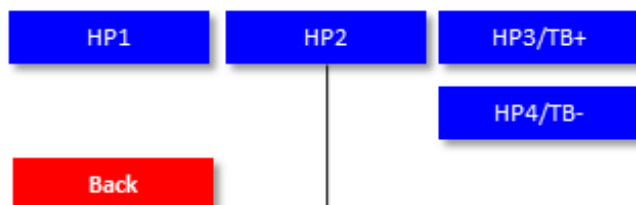

Touching each button activates the output circuit and the 'ARM' LED will light.

LP Events are tested the same fashion only the 'ARM' LED does not light.

→ Main >Utilities >Test Outputs >LP

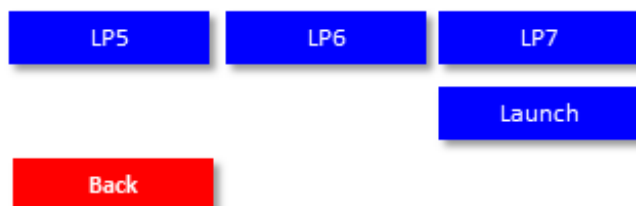

Smart Drop button will run an internal self test. ←

Timing button will run an internal self test. ←

Main >Utilities >Test Inputs

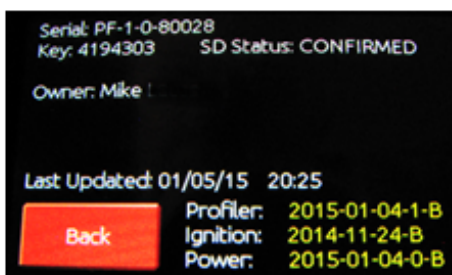
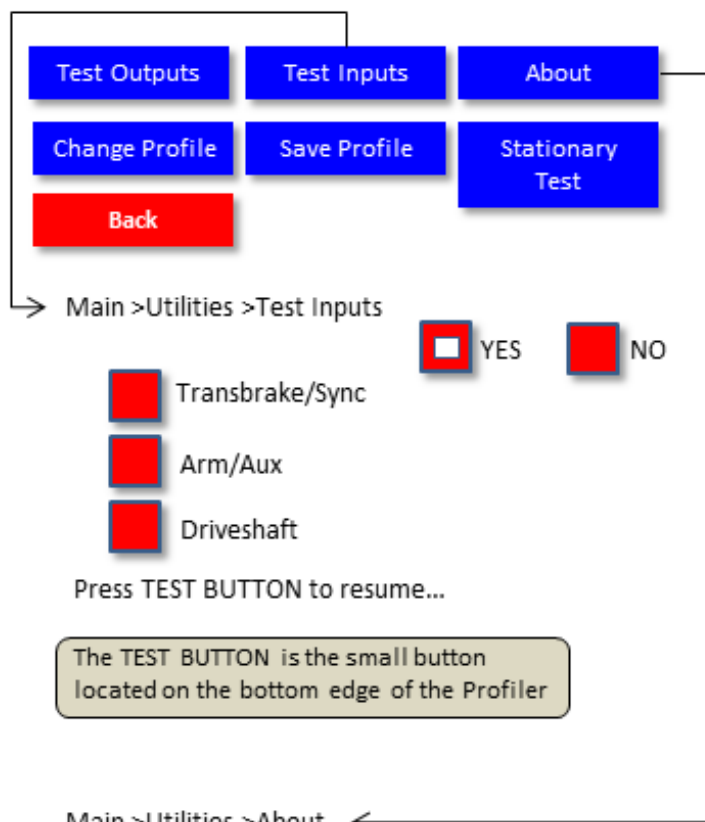

Main >Utilities

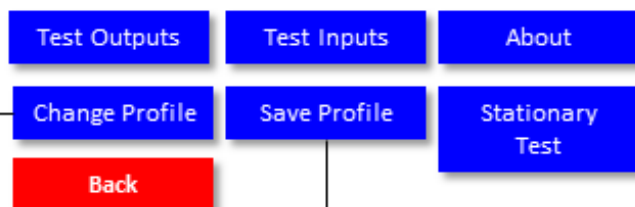

→ Main >Utilities >Change Profile

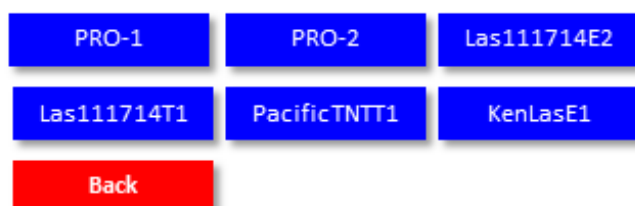

You can load any of the saved Profiles from here without connecting to a PC.

Main >Utilities >Save Profile ←

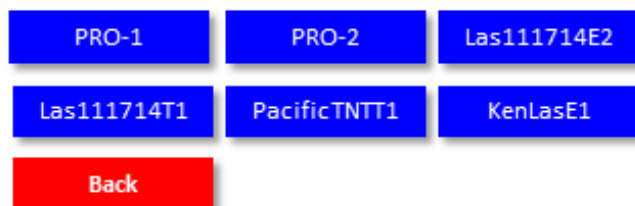

Main >Utilities >Stationary Test ←

Profiler disables Corrections, then begins a Stationary test of the loaded Profile.

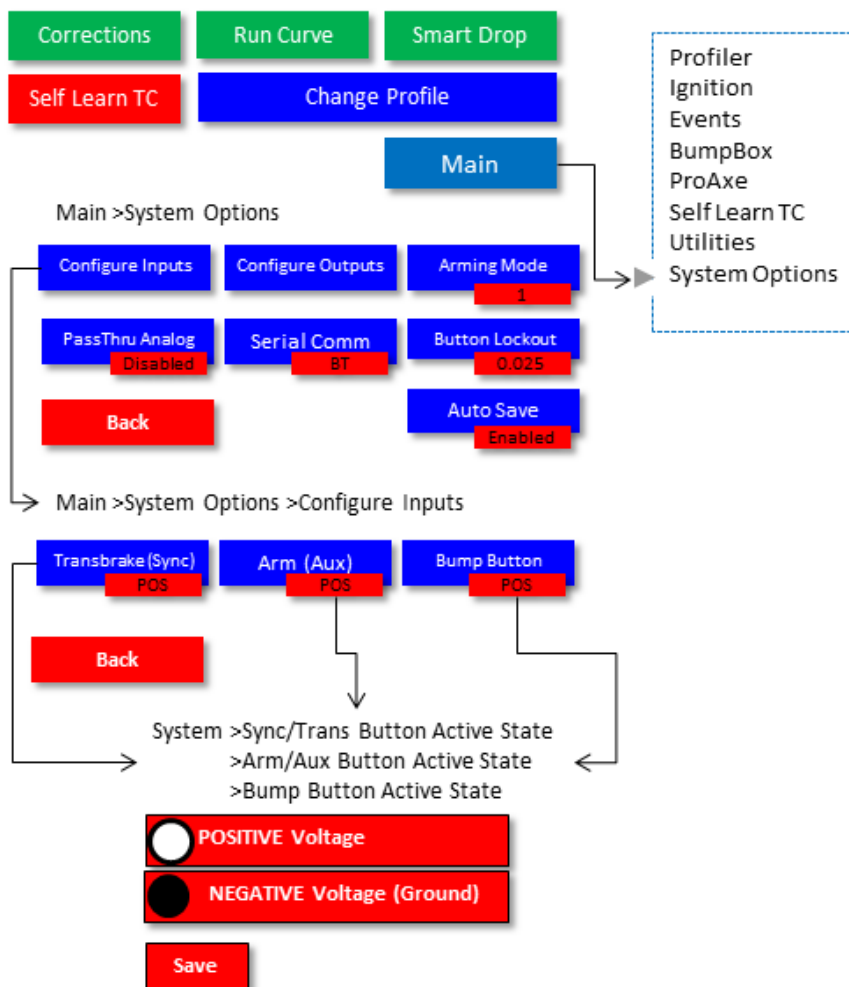

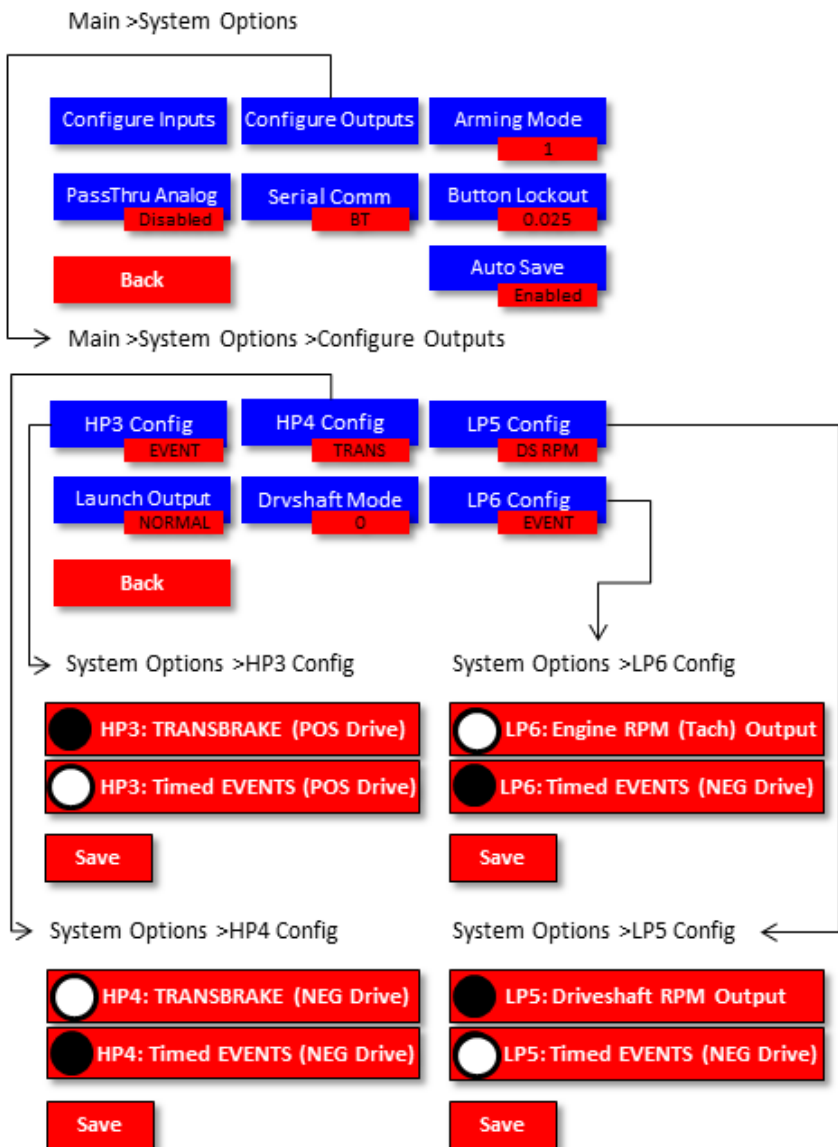

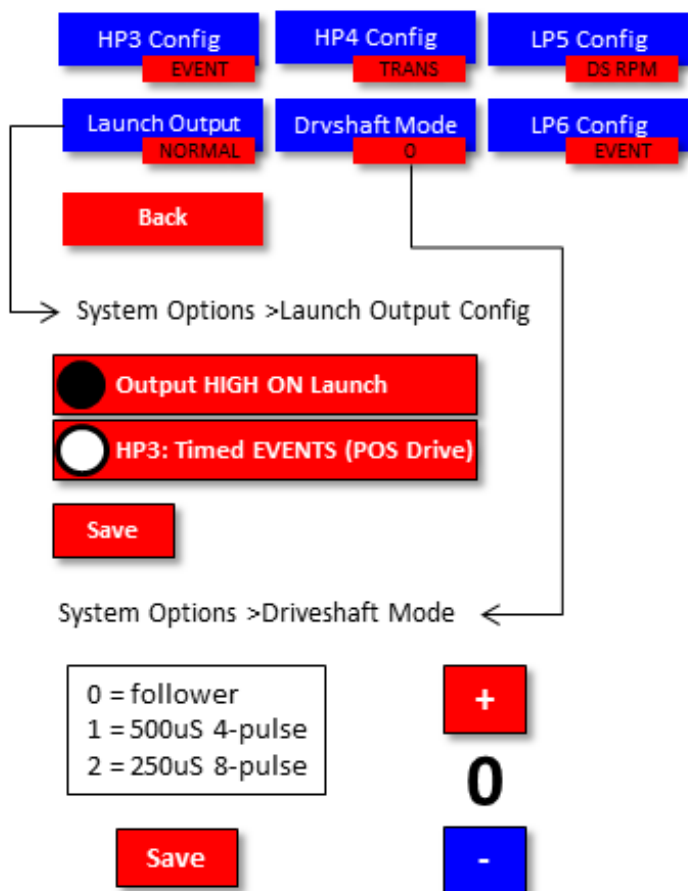

Main >System Options

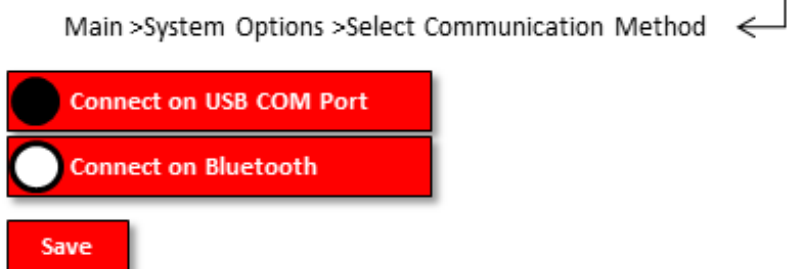
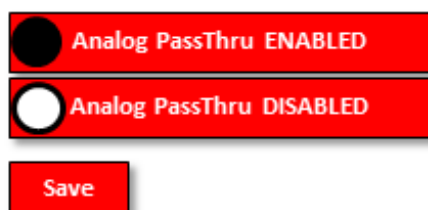
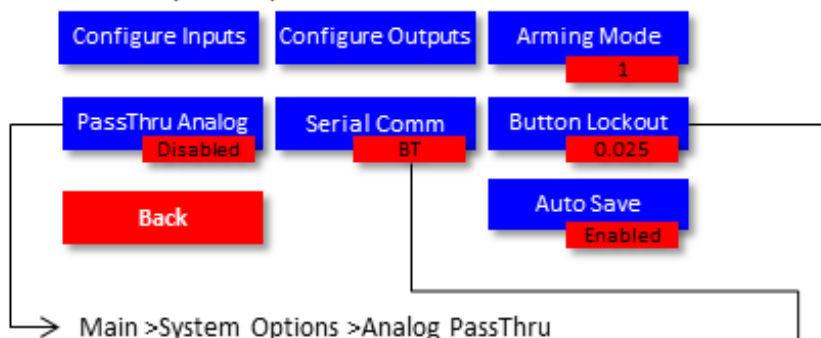

Main>System Options>Button Lockout

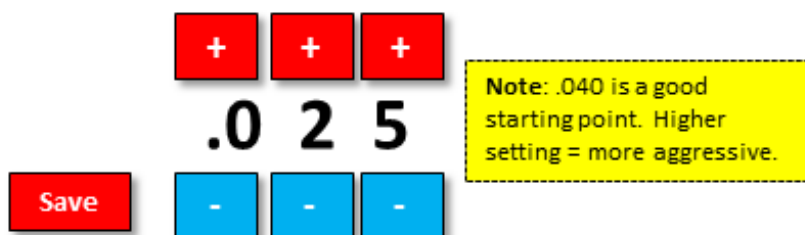

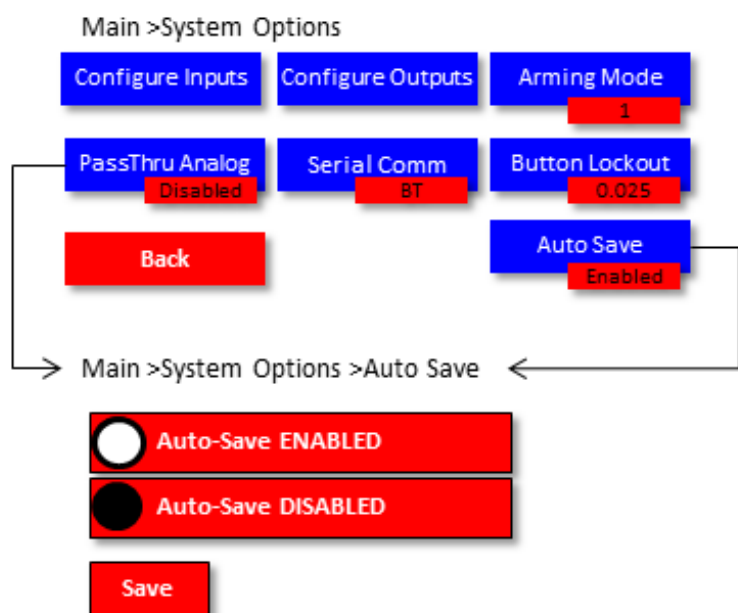

Appendix 9 Events Setup & Examples

The following are examples of how you might use and set up Events to control functions in your car.

Profiler Shift Control

The screenshot shows two event configuration panels for an event named "Shift".

- Event 1:**
 - Name: Shift
 - Channel: Disable, Enable
 - Pulsed Hz: 20
 - On At: 1.50
 - Off At: 2.50
 - Duty Cycle: 0
 - Ramped Event
 - Trigger Condition: No Triggers, Button only, RPM Only, Button or RPM
 - RPM: Above: 7400, Below
 - RPM Source: Driveshaft, Engine
 - Trigger Mode: Start, End, Shift Light
- Event 2:**
 - On At: 2.9
 - Off At: 3.8
 - Duty Cycle: 0
 - Ramped Event
 - Trigger Condition: No Triggers, Button only, RPM Only, Button or RPM
 - RPM: Above: 7600, Below
 - RPM Source: Driveshaft, Engine
 - Trigger Mode: Start, End, Shift Light

This following is an example of using **HP1** to control an air or electric 3 speed shifter. We want the 1-2 shift at 7,400 RPM and the 2-3 shift at 7,600 RPM. We know from previous runs that the 1-2 shift occurs at roughly 1.8 seconds into the run and the 2-3 shift occurs at approximately 3.2 seconds.

Named the Event "Shift"

We're not pulsing and Event is **Enabled**.

We don't want to have the car shift before 1.5 seconds into a pass or later than 2.5 seconds. 2nd gear shift window is 2.9 seconds to 3.8 seconds.

We're shifting 1-2 at 7,400 **Engine RPM**. The 2-3 shift will occur at 7,600 RPM

NOTE: RPM >Below means the output will be inverted upon activation.

We use **Shift Light Mode** for both shifts so we power the shifter solenoid once and turn it **OFF each Event**.

We are not using a **Ramped Event** so both are **Disabled** (un-checked) in this example.

The “Shift” Event would look like this. The first shift will occur at 7400 and the second shift at 7600.

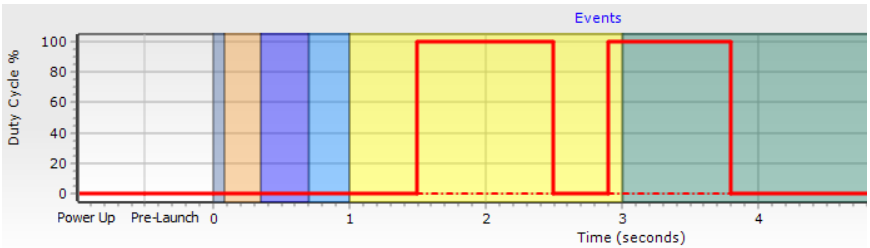

Linked & Ramped High Power Events

The following example is more complex and uses Linked and Ramped Events to control a non-specific device. It shows the flexibility and power of the Events functions in the Profiler. The Profiler can perform many of the functions of multiple external boxes and modules in your car and minimize wiring, weight, etc.

In this example we will ramp the device on to 50% from the launch, leave it at 50% until 1 second, make it 100% until 2 seconds, then turn it Off. It will stay off until 2.75 seconds then turn back 100%

until 3.5 seconds where it is ramped off at 4 seconds. The Event is programmed as shown below:

Name: HP1		Channel: <input type="radio"/> Disable <input checked="" type="radio"/> Enable	Power Up State: <input checked="" type="radio"/> Off <input type="radio"/> On	Pre-Launch State: <input checked="" type="radio"/> Off <input type="radio"/> On	TPS Mode: <input checked="" type="radio"/> Disable <input type="radio"/> Restart at
<input checked="" type="checkbox"/> Pulsed Hz: 20					<input type="radio"/> Resume <input type="radio"/> Restart at

Event 1	Event 2	Event 3	Event 4	Event 5
On At: 0	On At: 0.5	On At: 1	On At: 2.75	On At: 3.5
Off At: 0.5	Off At: 1.0	Off At: 2.0	Off At: 3.5	Off At: 4
Duty Cycle: 50	Duty Cycle: 50	Duty Cycle: 100	Duty Cycle: 100	Duty Cycle: 0
<input checked="" type="checkbox"/> Ramped Event	<input type="checkbox"/> Ramped Event	<input type="checkbox"/> Ramped Event	<input type="checkbox"/> Ramped Event	<input checked="" type="checkbox"/> Ramped Event
Trigger Condition: <input type="radio"/> No Triggers <input type="radio"/> Button only <input checked="" type="radio"/> RPM Only <input type="radio"/> Button or RPM	Trigger Condition: <input type="radio"/> No Triggers <input type="radio"/> Button only <input type="radio"/> RPM Only <input checked="" type="radio"/> Button or RPM	Trigger Condition: <input type="radio"/> No Triggers <input type="radio"/> Button only <input checked="" type="radio"/> RPM Only <input type="radio"/> Button or RPM	Trigger Condition: <input type="radio"/> No Triggers <input type="radio"/> Button only <input checked="" type="radio"/> RPM Only <input type="radio"/> Button or RPM	Trigger Condition: <input type="radio"/> No Triggers <input type="radio"/> Button only <input checked="" type="radio"/> RPM Only <input type="radio"/> Button or RPM
RPM: <input checked="" type="radio"/> Above 3500 <input type="radio"/> Below	RPM: <input checked="" type="radio"/> Above 3500 <input type="radio"/> Below	RPM: <input checked="" type="radio"/> Above 3500 <input type="radio"/> Below	RPM: <input checked="" type="radio"/> Above 0 <input type="radio"/> Below	RPM: <input checked="" type="radio"/> Above 3500 <input type="radio"/> Below
RPM Source: <input type="radio"/> Driveshaft <input checked="" type="radio"/> Engine	RPM Source: <input checked="" type="radio"/> Driveshaft <input type="radio"/> Engine	RPM Source: <input type="radio"/> Driveshaft <input checked="" type="radio"/> Engine	RPM Source: <input type="radio"/> Driveshaft <input checked="" type="radio"/> Engine	RPM Source: <input type="radio"/> Driveshaft <input checked="" type="radio"/> Engine
Trigger Mode: <input checked="" type="radio"/> Start <input type="radio"/> End <input type="radio"/> Shift Light	Trigger Mode: <input checked="" type="radio"/> Start <input type="radio"/> End <input type="radio"/> Shift Light	Trigger Mode: <input checked="" type="radio"/> Start <input type="radio"/> End <input type="radio"/> Shift Light	Trigger Mode: <input checked="" type="radio"/> Start <input type="radio"/> End <input type="radio"/> Shift Light	Trigger Mode: <input checked="" type="radio"/> Start <input type="radio"/> End <input type="radio"/> Shift Light

This illustration shows how the Events will respond.

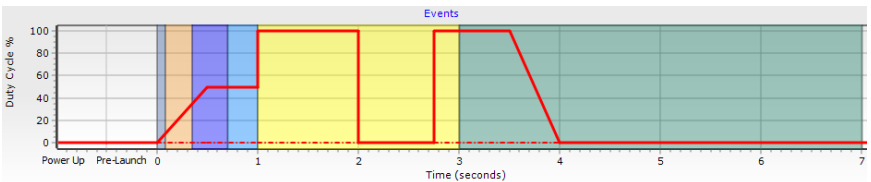

Low Power Events

The four **Low Power** outputs have a different set of setting parameters available than the High Power one's. Below is the parameter window for **LPS** as an example. Each output has options for up to 8 different "Event" settings.

Notice that the low power events Do NOT have the "Pulsed Hz" and ramping option. They are rated at .750mA and all **Neg** outputs.

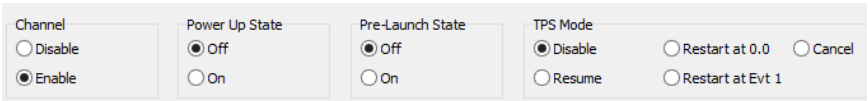
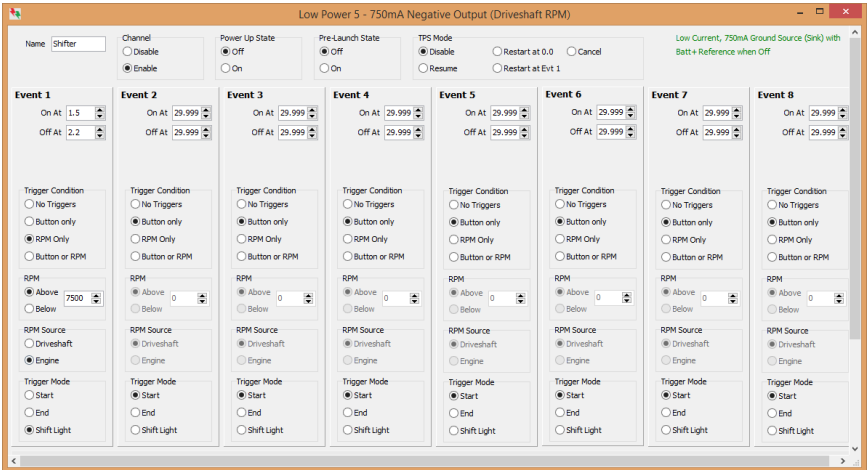

The TPS (Throttle Position Sensor) modes allow you to select what action you want taken if the car is pedaled during a run.

Below is an example of **Low Power Event 1**

Name

Event 1

On At

Off At

Trigger Condition

No Triggers

Button only

RPM Only

Button or RPM

RPM

Above

Below

RPM Source

Driveshaft

Engine

Trigger Mode

Start

End

Shift Light

Settings are the same as for the High Power Events **minus** the ability to set Pulsed Hz, Duty Cycle, & Ramping. Again they are all Neg outputs rated at 750mA.

These can be used for applications that have a lower current draw.

RPM Below means it will be **On** until the target RPM is matched, toggle momentary **Off**, then back On again. (Inverted)

The graphic shows the shift window time is 1.5 to 2.2 seconds into the run and will shift at 7500 RPM. This prevents a shift if the tires spin earlier than 1.5 seconds or after 2.2 seconds.

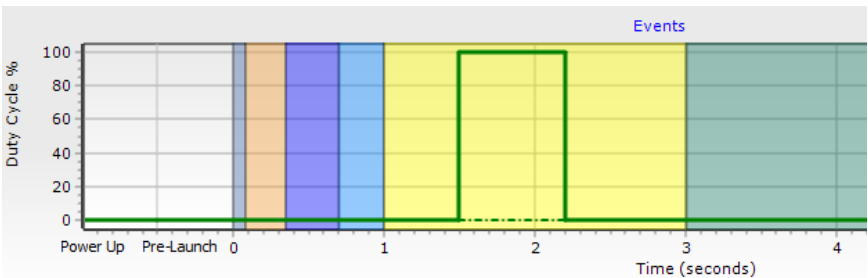

Appendix 10 Installing Bump Box & Trans-Brake

The Bump Box module operates by releasing the transmission brake for a preset, adjustable period of time. The time period must be adjusted to suit the combination in which it is installed.

It may take a bit of experimentation to arrive at the setting that will result in the perfect “Bump” you want. Some racers like to bump to the second bulb in just one bump, while others may like to take three smaller bumps to move to the second bulb.

You will need to install a momentary switch on the steering wheel to control the “Bump”. You will apply the Trans-Brake button as normal then tap the “Bump” button to move into the beams, then release the Trans-Brake as normal.

You will connect the Bump button to the Profilor using the **Pink** wire pin 10 in the 26 pin harness plug on the Profilor. The BumpBox activation wire can be configured in the **Settings >System Options** window. If you are activating the BumpBox with a button that has a + voltage on it, **Select >Positive Voltage**. If your button provides a ground, **Select >Negative Voltage (Ground)**

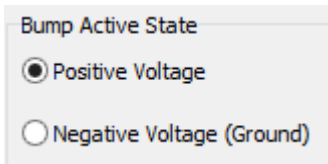

Pro-Axe

Once the Profilor is wired to control the Trans-Brake, the built in Pro-Axe delay box can be activated by simply programming in the amount of delay you wish to use by using the touch screen menu **>Main >ProAxe** or through the Profilor PC software by going to **Settings >ProAxe** in the top menu bar. If you choose NOT to use the Pro-Axe, set the time to 0 and it will not be active.

Trans-Brake Wiring

30 Amp Ground Switching Install

Use the following installation guideline for installations using a 30A **ground** switching trans-brake.

The 30 Amp **Ground** switching comes from the Profiler Pin 6 (**Orange wire**) per the connector pin-out table.

Do NOT use any type of mechanical relay.

- Connect the Orange wire to solenoid Ground wire.
- Connect the Orange wire to the original solenoid Ground wire.

30 Amp Positive Switching Install

Use the following wiring for installation using a **positive** switching trans-brake.

- The 20 amp positive wire comes from the Profiler connector pin 3 (Yellow wire).
- Connect Yellow wire from the Profiler pin 3 to the trans-brake solenoid Positive wire.

Appendix 11 Speedwire Systems™ Integration

If you have a Speedwire Systems™ 8 circuit car wiring controller in your car and/or their Nitrous controller, you can integrate the Profiler in several ways.

Arming Profiler

If you have a Speedwire Systems™ nitrous controller you can wire your Profiler arming to the Nitrous arming circuit so any time it's turned on, the Profiler will automatically armed to eliminate the need for an external switch of some kind.

Connect the Profiler Tan wire Pin 8 to the Speedwire Nitrous controller screen header pin #6 as shown below. This pin will be +12v any time the nitrous system is Armed.



To Profiler Pin 8

Next, ensure the arming circuit is configured for a + (Positive) input signal. This can set configured from either the PC software or the Touch Screen menu.

From PC software

- System Options Tab > Configure Inputs > Arm/Aux Active State > **Positive Voltage**

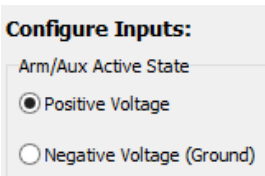

From Touch Screen

- Main >System Options > Configure Inputs >Arm >**Positive Voltage**

Trans-Brake Nitrous Lockout

If you want to have the Profiler activate your Trans-Brake(recommended), use the built in BumpBox , and/or ProAxe, you will want to retain your nitrous lock-out when the Trans-Brake is activated. You can move the Trans-Brake to the Profiler but leave the existing wiring that is on the Speedwire 8 circuit car wiring controller (Trans-Brake post) such as the MSD Dark Blue wire, etc.

Connect the Profiler Blue wire pin #20 (Launch Sync Trigger Out) to the Speedwire 8 circuit board header as shown below.

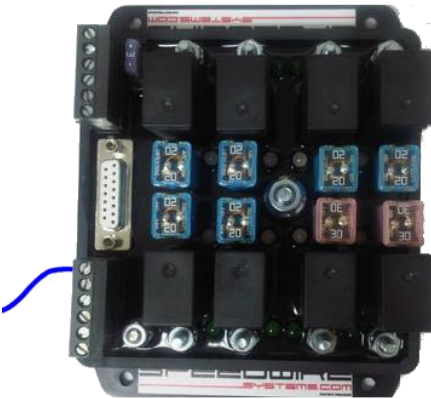

You will need to configure the input to Negative when the Trans-Brake is activated.

From PC Software

- System Options Tab > Configure Outputs >Launch Output >**Inverted**

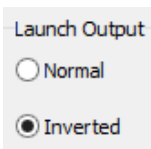

From The Touch Screen

- Main >System Options > Configure Outputs >Launch Output >**Inverted**

Benefits:

Now when the Trans-Brake button is activated, the Speedwire Systems™ circuits for Nitrous lock-out and Trans-Brake connected wires will activate as normal, plus you will have the advantages of the Profiler platform controlling the Trans-Brake.

- Very quick TB solenoid release (all solid state push-pull)
- Option to use **Bump Box** (repeatable & precise staging)
- Option to use **Pro-Axe** (better reaction times)

Appendix 12 Disclaimer

DAVIS TECHNOLOGIES PRODUCTS ARE FOR CLOSED COURSE USE ONLY

The following terms and conditions apply to all products manufactured and sold (“Products”) by Davis Technologies, LLC (“Davis”).

1. **ASSUMPTION OF RISK** – The Products are designed and manufactured for use on closed courses only. The purchaser and/or user of the Products assumes the risk that proper precautions are at all times in place for the use of the Products and for the safety of the user of the Products and other persons (such as, without limitation, spectators and course workers).

2. **FULL AND FINAL RELEASE AND WAIVER OF LIABILITY AND ALL CLAIMS** - Vehicle racing is an inherently dangerous sport with significant risk of personal injury and death. The Purchaser and/or end user of the Products WAIVE AND FULLY RELEASE any owner, officer, employee or agent of Davis from any and all liability for any loss, damage, injury or expense that the Purchaser and/or end user may suffer as a result of the use of the Product due to any cause whatsoever, including negligence, gross negligence, breach of contract, or breach of any statutory or other duty of care.

3. **AGREEMENT TO INDEMNIFY, TO SAVE AND HOLD HARMLESS** – The Purchaser and/or end user agree to indemnify and to save and hold harmless any owner, officer, employee or agent of Davis from any litigation expense, legal fees, liability, damage, award or cost, of any form or type whatsoever, they may incur due to any claim made against them or any one of them by Purchaser and/or end user, or Purchaser and/or end user’s estate, whether the claim is based on the negligence or the gross negligence of Purchaser and/or end user, or otherwise as stated above.

4. **PROPER USE OF PRODUCTS** – Purchaser and/or end user are solely responsible that the intended and actual use of any Product is made in compliance with any manuals provided with the Product or other information provided by Davis in writing and which specifically references the Product. Purchaser and/or end user may not rely on

any oral information or statements provided by Davis or in any forum or other source of information regarding the Products. It is the Purchaser and/or end user's responsibility to inspect and verify the dimensions, specifications, and performance of the Products as being appropriate for the use to which the user will put them prior to any actual installation and/or use. The Products are to be inspected by the Purchaser and/or end user before each use for evidence of damage, defect or wear. The installation of the Products may adversely affect other vehicle components, safety equipment or manufactured goods (collectively "goods"). Davis assumes no responsibility for any damage to other goods, or bodily injury that may arise due to failure of other goods, due to installation and/or use, either proper or improper, of its Products.

Davis agrees to inspect any Product up to sixty days after the date of original purchase from Davis and may, at its sole discretion, replace any Product that it determines does not comply with specifications. Shipping to and from Davis is at Purchaser's sole expense. Otherwise, the products (including parts resold by Davis) are sold "As Is" without any warranty, written or oral whatsoever. Express warranties, implied warranties, warranties of merchantability and warranties of fitness for a particular purpose are excluded. The entire risk of quality and performance of the products is with the buyer, user, subsequent user, or agent thereof (herein "user"). Should the products prove defective following their purchase, the buyer and not Davis any distributor(s), or retailer(s), assume the entire cost of all necessary services or repair as result of a product failing.

Davis disclaims all liability for any special, direct, incidental or consequential damages, or any damages whatsoever, including, without limitation, the loss of life or limb, or damages due to bodily or personal injury, which may arise or result from the sale, installation, or use of the products.

Contact Information

Technical Support and Sales may be reached at:

Davis Technologies, LLC.
PO Box 8250
Asheville, NC. 28787

(828) 645-1505

(828) 645-1525 fax

E-mail: support@moretraction.com

Web: www.MORETRACTION.com

Thank you for choosing



www.MORETRACTION.com

