

FuelTech



FT600

OWNER'S MANUAL

1. index	
2. Presentation.....	5
3. Warranty terms	6
4. Characteristics.....	7
4.1 Harness connections A-connector	9
4.2 Harness connections B-connector	11
4.3 Output table of FT600	12
4.4 GearController Connector	13
4.5 Auxiliary outputs	13
4.6 Internal MAP sensor	13
4.7 USB port	13
4.8 FuelTech CAN network.....	13
5. First steps with FT600 read before installation	14
6. Getting to know the ECU.....	14
6.1 Dashboard.....	14
6.2 Main menu.....	14
6.3 FTManager shortcuts.....	16
6.4 Dashboard screen.....	16
6.5 Diagnostic panel.....	17
6.6 Test time based features.....	18
6.7 Internet Remote Tuning.....	18
7. Engine settings.....	19
7.1 Engine setup	19
7.2 RPM signal.....	21
7.3 Ignition	23
7.4 Fuel injection.....	24
7.5 Pedal/Throttle	25
7.6 Idle actuators	27
7.7 FuelTech base map.....	27
7.8 Fuel injectors deadtime.....	28
7.9 Ignition Dwell	28
7.10 Ignition energy	28
7.11 Map options.....	29
7.12 Advanced map options.....	29
8. Electrical installation.....	30
9. FT600 connection on FT500 installation	31
9.1 Ignition calibration.....	31
10. Fuel injectors.....	33
11. Ignition.....	33
12. Sensors and actuators.....	39
12.1 Intake air temperature sensor	39
12.2 Engine temperature sensor.....	39
12.3 Fuel and oil pressure	39
12.4 Throttle position sensor (TPS)	39
12.5 Crank trigger/RPM sensor.....	39
12.6 Camshaft position sensor.....	43
12.7 O2 sensor	43
12.8 Step motor – idle speed.....	44
13. Auxiliary outputs.....	45
13.1 Cooling fan 1 e 2	45
13.2 Idle valve	45
13.3 Air conditioning.....	45
13.4 Shift Alert.....	45
13.5 Fuel pump.....	45
13.6 Variable camshaft control/Powerglide gearbox.....	45
13.8 Boost Control – N75.....	46
13.7 Progressive nitrous control	46
13.9 BoostController	47
14. Electronic throttle control.....	48
14.1 Connection table – throttle bodies and pedals	48
15. Sensors and Calibration	49
15.1 TPS calibration	49
15.2 Electronic throttle/pedal calibration	49
15.3 Fuel/oil pressure sensors inputs.....	50
15.4 Intake air and engine temperature sensors	50
15.5 O2 sensor inputs	51
15.6 Speed inputs	52
15.7 Driveshaft RPM and Input shaft RPM	53
15.8 Driveshaft RPM.....	53
15.9 Gearbox RPM	53
15.10 Gear detection.....	53
15.11 Nitrous bottle pressure	54
15.12 Clutch position.....	54
15.13 Clutch pressure	54
15.14 Ride Height.....	55
15.15 Pitch Rate	55
15.16 CAN communication.....	55
15.17 EGT.....	55
15.18 Wastegate Pressure.....	56
15.19 Internal accelerometer	56
15.20 Brake Pressure	56
15.21 Front and rear shocks	56
15.22 Flex Fuel	56
15.23 CounterPressure.....	56
15.24 Oil pan pressure	57
15.25 Transmission pressure	57
15.26 Transmission temperature.....	57
15.27 Torque converter pressure	57
15.28 Intercooler temperature	57
16. Starting the engine for the first time.....	58
16.1 First engine start	58

16.2 Ignition calibration	58	19.16 Wastegate boost pressure control	78
17. Fuel tables adjust	59	19.17 Power shift (GearController)	83
17.1 Main fuel table	59	19.18 Start Button.....	84
17.2 Overall fuel trim	59	19.19 RPM activated output.....	85
17.3 RPM compensation	59	20. Drag race features.....	86
17.4 O2 Closed Loop	60	20.1 Burnout mode	86
17.5 Idle speed by TPS table	61	20.2 3-step (boost spool)	86
17.6 Acceleration fuel enrichment and decay	61	20.3 2-step rev limiter	87
17.7 Engine temperature compensation	61	20.4 Linelock Brake Control.....	89
17.8 Intake air temperature compensation	62	20.5 Timing table for rev launch	89
17.9 Battery voltage compensation.....	62	20.6 Gear shift output.....	89
17.10 MAP / TPS compensation	62	20.7 Time based fuel enrichment.....	90
17.11 Prime pulse	62	20.8 Pro-Nitrous.....	92
17.12 Engine start.....	63	20.9 Time based output	94
17.13 Post-start enrichment.....	63	20.10 Wheelie Control.....	95
17.14 Individual cylinder trim.....	63	20.11 Davis Technologies.....	95
17.15 Rotor compensation	63	20.12 Staging control	96
17.16 Fear based compensation.....	64	20.13 Time based throttle opening	96
17.17 Gear shift fuel enrichment.....	64	21. Alert settings.....	97
17.18 Fuel injection phase angle table.....	64	21.1 Safe mode RPM limiter	97
18. Ignition tables adjust.....	65	21.2 Alerts	97
18.1 Main ignition table.....	65	22. Favorites.....	98
18.2 Overall ignition trim.....	65	23. Interface settings	99
18.3 MAP/TPS compensation.....	65	23.1 Day/night mode selection.....	99
18.4 Engine temperature compensation	66	23.2 LCD backlight settings.....	99
18.5 Intake air temperature compensation	66	23.3 LED configuration.....	99
18.6 Rotary timing split	66	23.4 Alert sound settings.....	100
18.7 Individual cylinder trim	66	23.5 Dashboard setup	100
18.8 Rotor compensation	66	23.6 Startup screen selection.....	101
18.9 Timing limits	67	23.7 Password Protection setup	101
18.10 Engine Start	67	23.8 Clear peaks.....	102
18.11 Gear compensation.....	67	23.9 Measurement units.....	102
18.12 Gear shift compensation.....	67	23.10 Demonstration mode.....	102
18.13 Gear shift compensation.....	68	23.11 Touchscreen calibration.....	102
19. Other functions	69	23.12 Serial number and software version.....	102
19.1 Internal datalogger	69	24. File manager.....	103
19.2 Accelerometer and gyroscope	70	24.1 FuelTech base map generator	103
19.3 Idle speed control.....	71	24.2 Edit map file name	103
19.4 Deceleration cut-off	73	24.3 Copy map to another file	103
19.5 Revolution limiter	73	24.4 Erase file	103
19.6 Shift Light.....	74	25. Rotary engines setup.....	104
19.7 Electric fans 1 and 2.....	74	25.1 Crank angle sensor installation and alignment.....	104
19.8 Air conditioning.....	74	25.2 Crank angle sensor wiring	104
19.9 Fuel pump.....	74	25.3 ECU setup	105
19.10 Cold start auxiliary.....	75	25.4 Ignition coils wiring	105
19.11 Camshaft control	75	26. FT600 – electrical diagram	106
19.12 Progressive nitrous control.....	75		
19.13 Generic duty cycle output.....	77		
19.14 Boost activated output.....	78		
19.15 Tachometer output.....	78		

2. Presentation

We want you to know that this is the same exact equipment that has helped propel race teams all over the world to the winner's circle. Whether it be for a street car, motorcycle, jet ski, boat, ATV or professional series drag race combination...we have you covered! The FT600 represents over a decade of high performance engine management knowledge and the latest technology to help take your racing program to the next level. From all of us at FuelTech, we wish you fun on your path and many victories because winning is in our DNA!

The FuelTech FT600 is a fully programmable ECU, which allows you to change all fuel and timing tables, as the engine conditions, in real time. You can tune your engine directly on the ECU, through its screen touchscreen 4.3" or via FTManager software with high-speed USB communication. The tuning of main fuel and timing tables may be performed in basic (2D) or advanced (3D) mode with configurable break points. It can be applied to any type of engine Otto cycle using indirect injection, 2 or 4 strokes, up to 12 cylinders or 4 rotors, gasoline, ethanol, methanol, CNG, nitromethane and other compatible fuels.

The electronic throttle control is fully integrated to the module and configured directly in the display without any additional computer or module. It is possible to set alerts to dangerous situations for the engine, such as over rev, low oil pressure, high engine temperature, among others. These alerts can also be programmed to limit rpm or shut off the engine bringing more security the user. The ECU also features five maps fully independent, allowing different settings to engines and/or cars.

The timing control can be done through distributor or crank trigger. Thus, it is possible to work with a single coil, double coils or COP coils, on wasted spark or sequential ignition. The fuel injectors can work on sequential, semi-sequential or multipoint mode, with individual cylinder trim. Tune the injection phase angle is also possible.

The equipment also has the Favorites menu, which seeks to facilitate access to the main engine setup menus, allowing executing rapid changes in maps. The dashboard panel is fully configurable, where the user can change the display size and the types of readings for each parameter, as well as reading range presented on the screen.



3. Warranty terms

The use of this equipment implies the total accordance with the terms described in this manual and exempts the manufacturer from any responsibility regarding to product misuse

Read all the information in this manual before starting the product installation.



NOTE:

This product must be installed and tuned by specialized auto shops and/or personnel with experience on engine tuning.

Before starting any electric installation, disconnect the battery.

The inobservance of any of the warnings or precautions described in this manual might cause engine damage and lead to the invalidation of this product warranty. The improper use of the product might cause engine damage.

This product does not have a certification for the use on aircraft or any flying devices, as it has not been designed for such use purpose.

In some countries where an annual inspection of vehicles is enforced, no modification in the OEM ECU is permitted. Be informed about local laws and regulations prior to the product installation.

Important warnings for proper installation of this product:

- Always cut the unused parts of cables off NEVER roll up the excess.
- The black wire of the harness MUST be connected directly to the battery's negative terminal, as well as each one of the sensors' ground wires.
- It is recommended to connect the three black/white wires to the engine head or block, in order to avoid electromagnetic noise problems.



WARNING

- ***It is a good practice to save your maps on the PC, as a security backup. In case of problems with your ECU, this will be the guarantee that your calibrations are saved. In some cases, when the ECU is upgraded by the factory, its memory may be erased also.***
- ***It's not possible to change the FT600's interface language.***

Limited Warranty

This product warranty is limited to one year from the date of purchase and covers only manufacturing defects upon presentation of purchase invoice.

This ECU has a serial number that's linked to the purchase invoice and to the warranty. In case of product exchange, please contact FuelTech tech support.

Damages caused by misuse of the unit are not covered by the warranty. This analysis is done by FuelTech tech support team.

The violation of the warranty seal results in the invalidation of the Product Warranty.

Manual version 1.6 – January/2018

ECU version – 3.3

FTManager version - 3.3

4. Characteristics

Specifications

- Otto cycle engine control: 1, 2, 3, 4, 5, 6, 8, 10 and 12 cylinders;
- Wankel engines (rotary) 2, 3 and 4 rotors;
- Sequential, semi sequential and multipoint fuel control;
- Distributor and crank trigger ignition control;
- Wasted spark and sequential ignition control;
- Electronic throttle body Control (Drive-By-Wire);
- Idle speed control by electronic throttle, stepper motor, ignition timing and PWM valve;
- Closed loop injection through oxygen sensor (wide band lambda sensor);
- Real time programmable by the screen or PC through FTManager Software;

Inputs

- Differential input for RPM signal;
- Differential input for cam sync signal;
- 20 input channels totally configurable - digital and analogic (intake air temperature, coolant temperature, fuel and oil pressure, TPS, external MAP sensor, electronic throttle and pedal position sensors, etc);
 - 2 high sensibility inputs used preferably for gear shifter force sensor;
 - Editable sensors reading scale;
- Speed sensor and integrated gyroscope;
- 103 psi internal MAP sensor (7 bar - absolute), 14.7psi of vacuum and 88psi of positive pressure (boost);
- 1 USB port for computer and FuelTech software connection;
- 2 CAN ports for FuelTech FTCAN 2.0 or FTCAN 1.0 communication with FuelTech WB-O2 Nano, FuelTech EGT-8 CAN, Racepak IQ3, VNET, AiM, etc).

Outputs

- 32 configurable outputs channels:
 - 16 open collector outputs: recommended for high impedance injectors (up to 4 injectors per output) – it is possible to set up to 32 injectors using external FuelTech Peak and Hold ECU;
 - 8 open collector outputs with a 5V current source of: recommended for ignition control;
 - 8 PUSH-PULL or HALF BRIDGE outputs: suitable for ignition, step motor control, electronic throttle body and to activate loads by 12V instead of ground.

Injection control

- Sequential injection for 24 outputs;
- Closed loop fuel control through O2 sensor (wide band sensor);
- 2 injector banks (staged injection banks A and B);
- Main map to MAP or TPS to RPM;
- Main map 3D advanced until 32x32 points (completely adjustable map index and size);
- Simplified 2D map with up to 1x32 cells per MAP or TPS and RPM compensation of up to 1x32 cells (completely adjustable

- map index and size);
- Injection time resolution 0.001ms;
- Fuel enrichment and decay adjust;
- Individual cylinder trim setting by MAP or RPM;
- Injector compensation through:
 - Coolant temperature;
 - Air temperature;
 - Battery voltage (individual per bank);
 - Throttle position (TPS);
- Starting engine map with the engine temperature;
- Fuel pump prime control;
- Prime pulse and post-start enrichment maps;
- Gear based fuel compensation;
- Gear shift fuel compensation;
- Fuel injection phase angle control;
- Deadtime compensation table by battery voltage;

Ignition control

- Sequential ignition for up to 12 cylinders;
- Main map to MAP or TPS to RPM;
- Main map 3D advanced until 32x32 points (completely adjustable map index and size);
- Simplified 2D map with up to 1x32 cells per MAP or TPS and RPM compensation of up to 1x32 cells (completely adjustable map index and size);
- Ignition angle resolution 0.01°;
- Injection angle resolution of 0.01°;
- Timing compensation by air temperature;
- Timing compensation by engine temperature;
- Timing compensation by gear;
- Gear shift timing compensation;

Dashboard screen / Onboard computer

- Screen dashboard which displays different sizes and styles to be used with any existing equipment or sensor;
- Upper tab with 10 LED lights, colored RGB and adjustable progressive shift light;
- 4 RGB LED side lights which can be triggered by 3 different combined settings;
- Diagnosis dashboard with real-time information of all inputs, outputs, CAN and Status Events;

Internal datalogger

- Multiple logs recording, up to 256 channels;
- Configurable sampling rate per channel (25Hz, 50Hz, 100Hz and 200Hz);
- Advanced mode allows individual settings for the sample rate with 1, 5, 25, 50, 100 or 200Hz;
- Automatic activation by RPM, through the screen or by external button;
- Data storage for up to 2h50min (24 channels at 25Hz);
- FTManager Datalogger Software for viewing and comparing logs.

Drag race features

- Burnout mode, 2-step, 3-step;
- Timing table for rev launch;
- 2-step by wheel speed or pressure/position of clutch;
- Time based RPM limiter by timing retard or ignition cut;
- Time based wheel speed or driveshaft RPM control with timing retard or ignition cut;
- Time-based ignition timing compensation;
- Time-based fuel compensation;
- Pro-Nitrous setting for up to 6 stages, with activation control, fuel enrichment and ignition timing maps;
- Gear shift output;
- Time based output;
- Staging control;
- Line lock brake output;
- Wheelie control;

Other features

- Integrated GearController : ignition cut for clutchless gear shifting using a strain gage sensor on the shifter;
- Integrated BoostController: wastegate valve pressure control;
- Idle speed control by timing, step motor, PWM valve or electronic throttle body;
- Deceleration fuel cut-off;
- Control of up to two cooling fans by coolant temperature;
- Air conditioning control;
- Fuel pump control – with 6s prime;
- VTEC control;
- Progressive nitrous control with fuel enrichment and timing retard;
- Generic duty cycle control;
- Boost activated output;
- Different options for gear detection;

Protection and Alerts

- RPM limiter by fuel or ignition cut;
- Shift light with sound and dashboard alert and/or external shift light;
- Configurable safe mode options (RPM limit or engine shutoff):
 - High or low exhaust gas temperature (EGT), O2 closed loop limit, over boost, over rev, engine temperature, duty cycle, oil pressure, fuel pressure and differential fuel pressure.

General characteristics

- Display brightness adjusts;
- LED lights brightness adjustment;
- Night and day mode selection by external switch and through the menu;
- Audible and visual alert, including external shift light control;
- 5 memory positions to save different adjusts and maps;
- User and tuner protection passwords;
- PC communication through USB cable and channel customization via FTManager Software;
- Working temperature: -4 F a +158 F;
- Maximum power supply voltage: 20V;

ECU Dimensions

- 5.86 x 3.7 x 2.42 in;

Weight

- ECU: 20.74 oz;
- Box with wire harness: 117.25 oz
- Box without wire harness: 61.44 oz

Box content

- 1 FT600 ECU;
- 1 10ft wiring harness (optional to buy);
- 1 FT600 installation and operation manual;
- 1 mounting kit (4 rubber mounts, 4 washers and 4 1/4" nuts);
- 1 cover for FT600;
- 1 badge FuelTech FT600;
- 1 USB flash drive (contains FTManager Software, FT guides, etc);
- 1 Mini USB cable;
- 1 Pen;
- 1 Decals;
- 1 keychain;

4.1 Harness connections A-connector

Pin	Wire Color	Function	Information
1	Blue#1	Blue output #1	These outputs are usually used for injector control. When needed, they can be configured as auxiliary outputs.
2	Blue#2	Blue output #2	
3	Blue#3	Blue output #3	
4	Blue#4	Blue output #4	
5	Blue#5	Blue output #5	
6	Blue#6	Blue output #6	
7	Blue#7	Blue output #7	
8	Blue#8	Blue output #8	
9	Blue#9	Blue output #9	
10	Blue#10	Blue output #10	
11	Blue#11	Blue output #11	
12	Blue#12	Blue output #12	
13	Blue#13	Blue output #13	
14	Blue#14	Blue output #14	
15	Blue#15	Blue output #15	
16	Blue#16	Blue output #16	
17	Black/White	Power ground input	Ground (Engine block/head or battery)
18	Gray#1	Gray output#1	These outputs are usually used for ignition control. When needed, they can be set up as injector outputs or auxiliary outputs. By standard, Gray output #8 is used as a tachometer output.
19	Gray#2	Gray output#2	
20	Gray#3	Gray output#3	
21	Gray#4	Gray output#4	
22	Gray#5	Gray output#5	
23	Gray#6	Gray output#6	
24	Gray#7	Gray output#7	
25	Gray#8	Gray output#8	
26	Yellow#1	Yellow output#1	Electronic throttle and step motor outputs. Also used as injection or auxiliary outputs (cooling fan, fuel pump, etc.)
27	Yellow#2	Yellow output#2	
28	Yellow#3	Yellow output#3	
29	Yellow#4	Yellow output#4	
30	Yellow#5	Yellow output#5	
31	Yellow#6	Yellow output#6	
32	Yellow#7	Yellow output#7	
33	Yellow#8	Yellow output#8	
34	Red	12V input from relay	Connected to the pin 87 of the Main Relay.

A-connector diagram

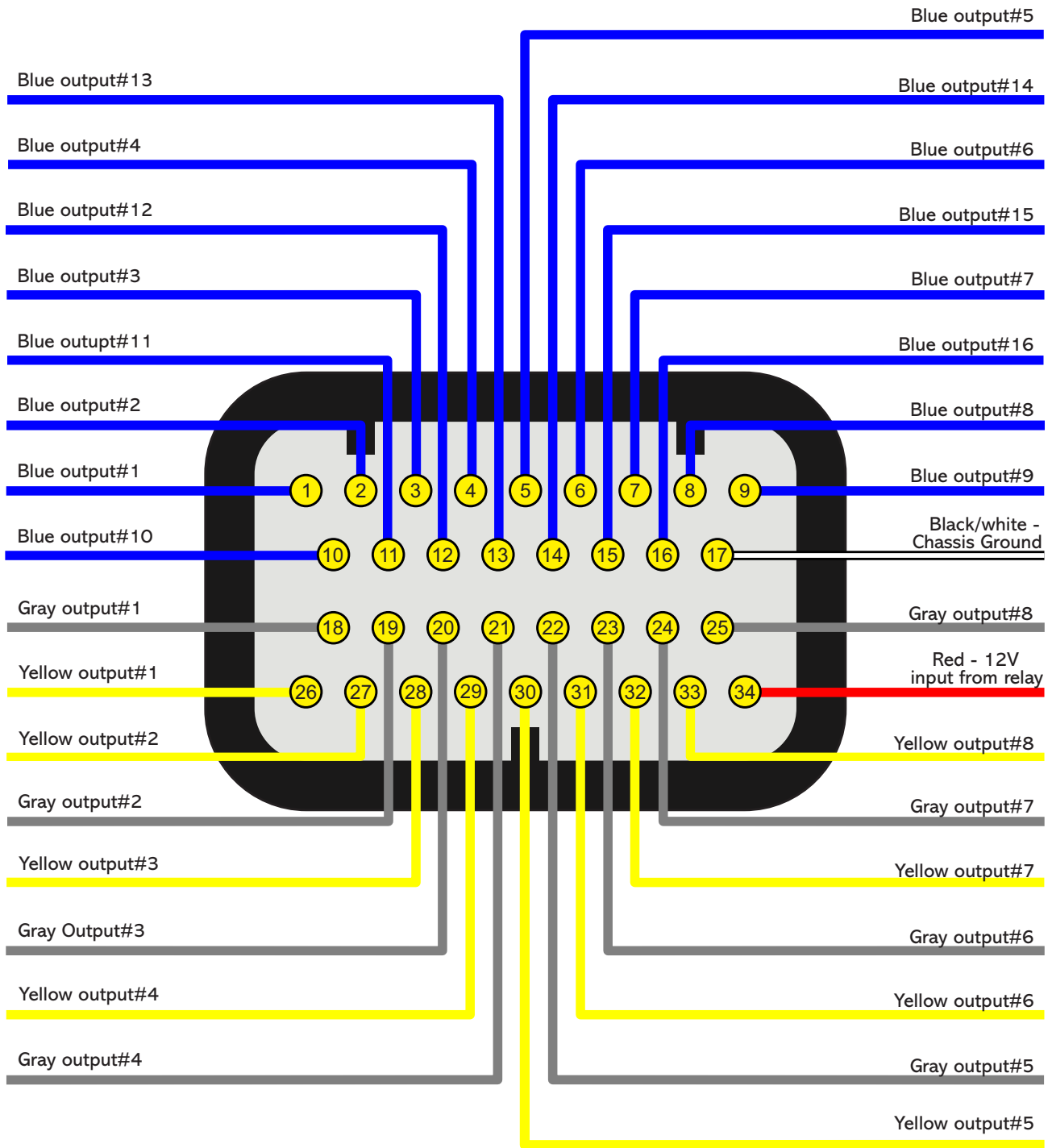

4.2 Harness connections B-connector

Pin	Wire Color	Function	Information
1	Red	RPM signal input	Connected to the crank trigger sensor (hall or magnetic) or to the distributor. To VR sensors, use the shield wire the sensor shield. To Hall sensor, use the shield as negative
2	White	Magnetic RPM sensor reference	Connected to the negative wire of the magnetic sensor. When OEM ECU is reading the sensor in parallel, split this wire with OEM sensor negative - Do not connect when using hall effect sensor.
3	Red	Cam sync signal input	Connected to the cam sync sensor (hall or magnetic)
4	White	Cam sync reference input	Connected to the cam sync sensor (hall or magnetic) - Use the shield as negative to the sensor
5	White#1	White input#1	Default: O2 sensor input
6	White#2	White input#2	Default: two-step input
7	White#3	White input#3	Default: Air conditioning button
8	White#4	White input#4	Default: Oil pressure
9	White#5	White input#5	Default: Coolant temperature
10	Black	Battery negative input	Connected directly to the battery negative with no seams. Do not connect this wire to the chassis, engine block or head.
11	Yellow/Blue	CAN A LOW	CAN A
12	White/Red	CAN A HIGH	
13	White#6	White input#6	Default: fuel pressure
14	White#7	White input#7	Default: Air temperature
15	White#8	White input#8	Default: pedal#2 signal input
16	White#9	White input#9	Default: pedal#1 signal input
17	White#10	White input#10	Default: MAP signal output, electronic throttle 1B input signal
18	Black/White	Power ground inputs	Ground (Engine block/head or Battery)
19	Black/White		
20	White/Red	CAN B HIGH	CAN B HIGH
21	White#11	White input#11	Default: TPS sensor
22	White#12	White input#12	Sensors input
23	White#13	White input#13	
24	White#14	White input#14	
25	White#15	White input#15	
26	Red	12V input from relay	Connected to the pin 87 of the Main Relay
27	Green/Red	5V outputs for sensors	5V voltage output for TPS, electronic throttle and pedal sensors
28	Yellow/Blue	CAN B LOW	CAN B LOW
29	Green/Black	Ground for sensors	Connected the sensors ground
30	White#16	White input#16	Sensors input
31	White#17	White input#17	
32	White#18	White input#18	
33	White#19	White input#19	Power Shift Input - Blue wire Strain gage sensor
34	White#20	White input#20	Power Shift Input - Orange wire Strain gage sensor

**NOTE:**

When using the GearController function connect the White wire from the shifter to ground for sensors Green/Black (pin #29).

**IMPORTANT:**

Fuel only: When using this option, the RPM signal input cannot be connected to a coil high voltage signal because the input has no protection and will damage the trigger input on the ecu. Please use a tach output, another rpm source or an ignition coil to tach adapter module to avoid damage to the unit.

B-connector diagram

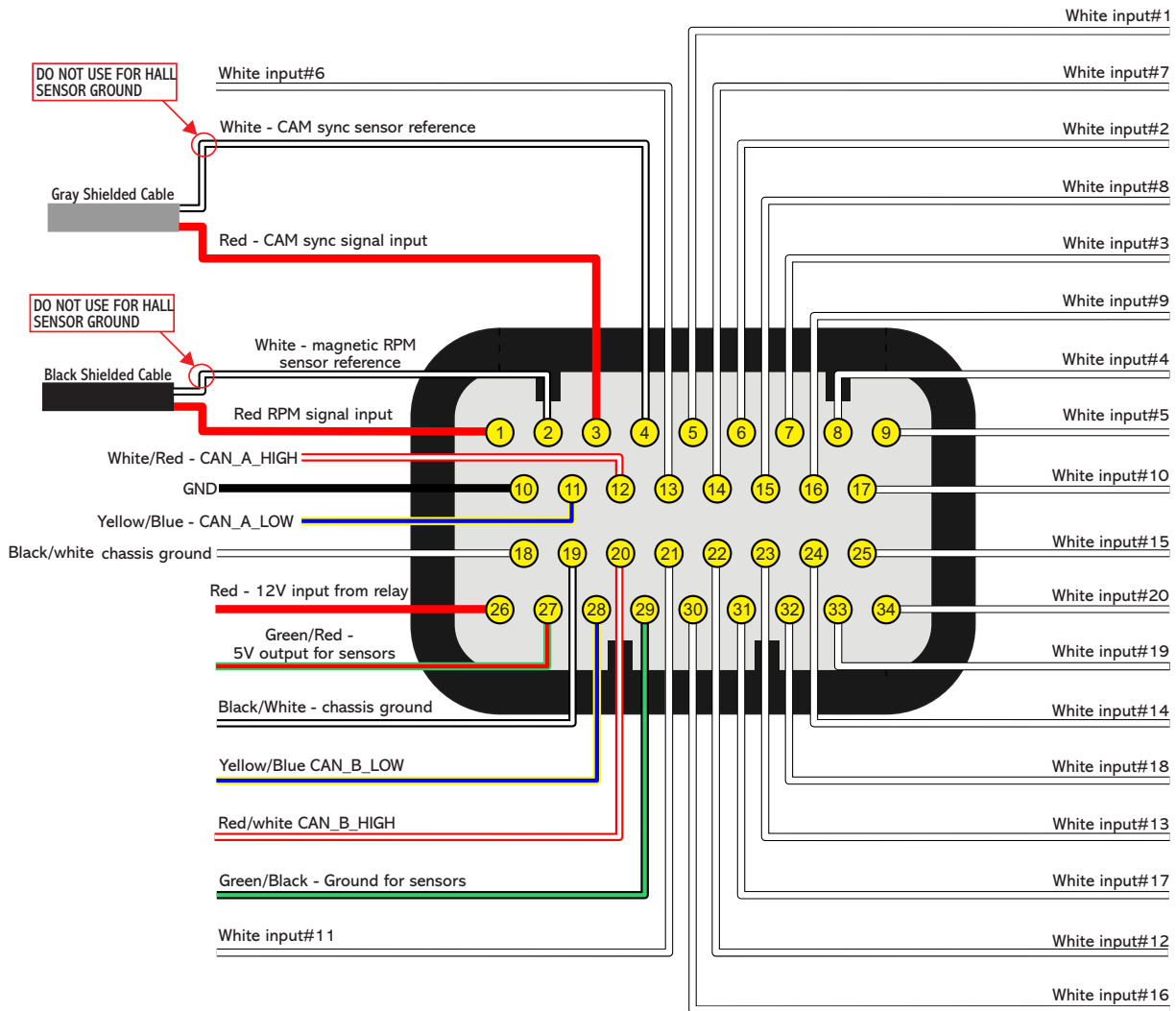

4.3 Output table of FT600

Wire color	Output type	Max current for negative activation (OV) for each output	Max current for positive activation for each output	Application	Notes
Blue	Open collector (Lo side)	5A*	Can't activate by positive	Fuel injectors, relays, solenoid valves	Triggers loads always by negative
Gray	Open collector with current source in 5V (Lo side)	1A*	30mA in 5V	Inductive ignition control, fuel injectors, relays, solenoid valves	Triggers loads always by negative
Yellow	PUSH-PULL or HALF BRIDGE	5A*	5A** in 12V	Electronic throttle, step motor, MSD/M&W and other ignitions activated by 12V	When used to control relays, valves or any other load by negative , there is a risk of 12V return to the ECU. This will keep the ECU always powered on. In this case, an external diode or a relay with built-in diode is required for protection.

* Total max current combined with all outputs triggering loads by negative: 30A continuous

** Total max current combined with all outputs triggering loads by positive: 20A continuous



NOTE:

Blue outputs cannot control ignition because they do not have a pullup resistor.

4.4 GearController Connector

The FT600 wiring harness comes with the gear strain gauge sensor connector. In case the vehicle isn't equipped with a gear strain gauge, this connector can be removed and it's white inputs can be used for other functions.



4.5 Auxiliary outputs

FT600's outputs can be set up in many different ways, they have different capacities according to the function. Bellow is some important information about them:

Blue outputs [#1 to #16]: by standard, used as injector outputs. Each one of them can control up to:

- 6 saturated injectors impedance above 10 Ohms (maximum of 24 injectors considering all of the blue outputs)
- 4 saturated injectors impedance between 7 and 10 Ohms (maximum of 16 injectors considering all of the blue outputs)

The use of a **Peak and Hold** driver is mandatory when the number of injectors is higher than the maximum quoted above or when using low impedance injectors (impedance below 7 Ohms).

During the Engine Setup configuration, blue outputs will be selected automatically from Blue #1 to Blue #16.

When more than 16 injector outputs are needed, the ECU will use Gray #1 to Gray #8 or Yellow #1 to Yellow #4. In this case, the use of a Peak and Hold driver is mandatory on Gray and Yellow outputs (for saturated and low impedance injectors).

Blue outputs not used to control fuel injectors may be used as auxiliary outputs (controlling fuel pump, cooling fan, etc.). In this case, the use of a relay is mandatory.

Gray outputs [#1 to #8]: by standard, used as ignition outputs. According to the engine setup, they can be set up as injectors or auxiliary outputs.

During the Engine Setup configuration, ignition outputs will be selected automatically from Gray #1 to Gray #8. It's not possible to have more than 8 ignition outputs.

Gray outputs not used for ignition control can be set up as injectors outputs (the use of a Peak and Hold driver is mandatory) or as auxiliary outputs (the use of a relay is mandatory).

Yellow outputs [#1 to #8]: by standard, they're as electronic throttle control (Yellow #1 and #2) or stepper motor control (Yellow #1 to #4). Yellow outputs not used for electronic throttle control can be set up as injectors outputs (the use of a Peak and Hold driver is mandatory) or as auxiliary outputs (the use of a relay is mandatory).

Tach output: by default, it is setup on in the gray #8, but if this pin is needed for other function, we recommend to use one of the yellow outputs for tach. If the yellow wires are being used, you can use any other output with a 1k ohms pull-up resistor connected from the signal to 12V.

4.6 Internal MAP sensor

This ECU is equipped with an internal MAP sensor. Use a **6mm pneumatic hose (4mm internal diameter)** to connect the sensor to the intake manifold. Pneumatic hoses are flexible, durable and highly resistant. Usually found in black or blue colors.

Silicon hoses are not recommended because they can be easily bent, blocking vacuum/boost readings on the ECU MAP sensor.

Use a hose exclusively for FT MAP sensor, avoiding splitting it with valves, gauges, etc. Connect it to any spot between the throttle and the engine head. Its length must be as short as possible to avoid lags and errors on the sensor readings. When using individual throttle bodies, it is a good idea to connect all intake runners into a single point and then connect to the FT MAP sensor; otherwise, MAP readings may be erratic or inaccurate.

4.7 USB port

The USB cable is used to update the ECU firmware version, setup maps and adjusts trough a computer and FTManager software and download data recorded by the internal datalogger.

4.8 FuelTech CAN network

FuelTech CAN port is a 4 way connector placed on the wiring harness of the ECU and is responsible for FT600 communication with other FT modules (as KnockMeter and GearController) and Racepak dashboards. A FuelTech CAN-CAN cable is used to establish a connection between them.



ATTENTION:

For the correct operation of the CAN Network, its mandatory to use the CAN resistor as shown in the following image.

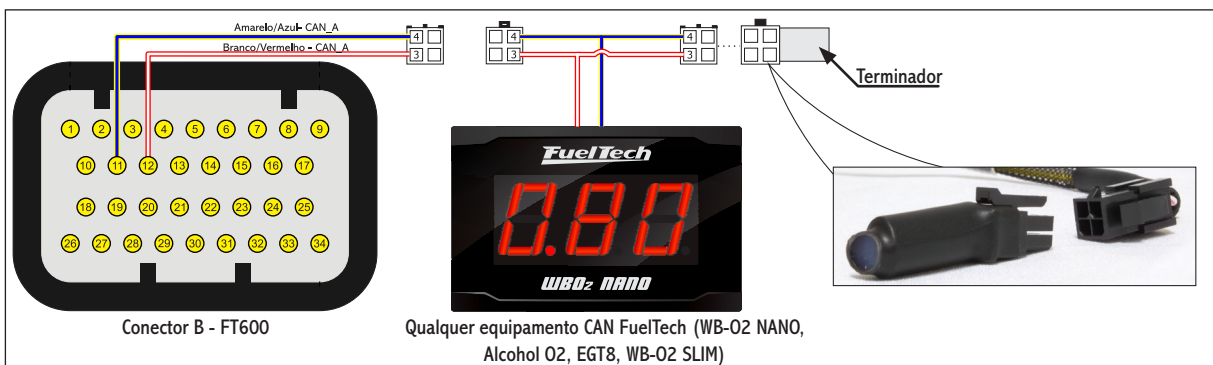

5. First steps with FT600 read before installation

This chapter is a step-by-step guide that must be followed to start FT600 basic setup before electric installation, as the function of each wire may vary according to engine setup (number of cylinders, injectors control mode, ignition coils and auxiliary outputs).

1. Connect the flash drive in the PC USB port and install the FTManager software. Remember to check if the software and the ECU are in the latest version at www.fueltech.net.
2. Connect FT600 to the computer using the USB cable included on the package. The ECU will be powered up;
3. With the ECU in hands go through chapter 6, that introduces all basic information about menu navigation and operation;
4. Chapter 7 guides the user through all the menus where data regarding the engine must be setup (crank trigger signal, injectors and ignition control modes, etc.);

5. The last step before the electric installation is to check harness connections. Go to the "Engine Setting" menu then click the last option "Wiring harness diagram". Check and write down the connections and use it as guide to know how functions were allocated to the pins.
6. Chapters 8 to 14 guide through details related to the electrical installation of injectors, coils, 12V inputs, grounds, sensors, etc. Chapter 25 shows full wiring diagrams as example for your installation;
7. Chapter 15 gathers information on sensors settings for temperature, pressure, RPM, speed, etc.
8. With the electric installation finished, proceed to chapter 15.14 and check all the information needed for the first start of the engine, ignition calibration, sensors checking, etc.
9. Lastly, chapters 17 to 24 show detailed descriptions about all functions of the ECU. It is a very interesting reading; it also details every function and operation that the FT can perform.

6. Getting to know the ECU

6.1 Dashboard

FT600 has a whole new dashboard, completely redesigned and customizable to improve visualization in any kind of vehicle.

- 1- Top LED bar (shift lights): configurable shift light by gear;
- 2- Side LEDs (alerts): many different options of activation and alerts;
- 3- Dashboard: fully customizable and redesigned with new gauges (3x2 size), besides a G meter;



NOTE:

For more info check chapter 23.11.



6.2 Main menu

Navigation through touchscreen is intuitive, because the ECU display makes the access to information very easy, eliminating physical buttons. So, all changes on maps, setups and functions are done by light touches on the screen.

To enter menus, press the screen twice, just like a double click. This is a feature that prevents the user from entering the wrong menu when managing the ECU inside the car.

- 1 - **Dashboard:** Shows real time engine information (RPM, Temperature, pressure, timing, injection time, etc.)
- 2 - **Fuel Tables Adjust:** Main fuel map, overall fuel trim, RPM compensation, TPS idle fuel table accel fuel enrich and decay, engine and intake temp, compensation battery voltage, compensation, post start enrich, ect.
- 3 - **Ignition Tables Adjust:** Main ignition map, overall ignition trim, MAP / TPS compensation, air and engine temperature compensations , individual cylinder trim, timing split, etc.
- 4 - **Alert Settings:** Access to shift alert settings, safe mode RPM limiter, alerts by fuel and oil pressure, TPS, etc.
- 5 - **Engine Settings:** Engine basics info as ignition mode, RPM signal, pedal/throttle settings, idle actuator, injectors deadtime, ignition dwell, wiring harness diagram.
- 6 - **Interface Settings:** LCD backlight and alert sounds, dashboard configs, measurement units, touchscreen calibration serial number and version.

- 7 - **File Manager:** Used to generate FuelTech Base Map, copy, delete and manager map files.
- 8 - **Sensors and Calibration:** Setup and calibrate FT600 sensors, electronic throttle, O2 sensor, etc.
- 9 - **Other Functions:** Internal datalogger, RPM limiter decel, fuel cut-off, thermatic fans, progressive nitrous, boost control idle speed, etc.
- 10 - **Drag Race Features:** Burnout mode 3-step, 2-step, spool assist table, Gear shift output, time based enrichment and timing Pro-Nitous.
- 11 - **Favorites:** Shortcuts to the most used menus and functions.
- 12 - **Diagnostic Panel:** Check inputs and outputs status and all information of what the ECU is reading and doing is real time.

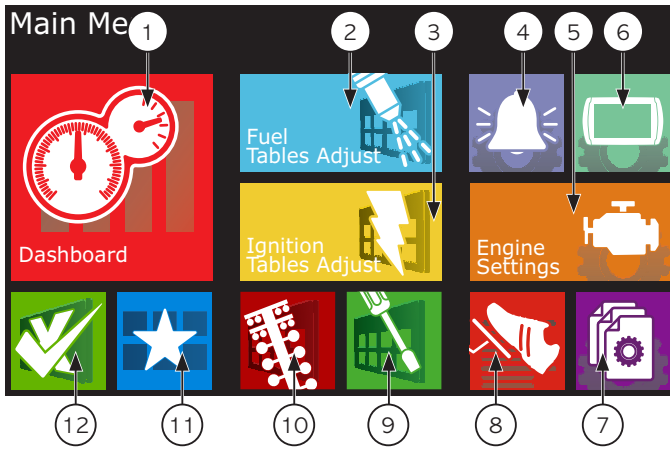

You can navigate through all menus with FTManager (available in the flash drive) and mini USB cable. The software initial screen is shown below:

- 13 - Quick access;
- 14 - Function table;
- 15 - Help;
- 16 - Function or map graph
- 17 - Real time dashboard;

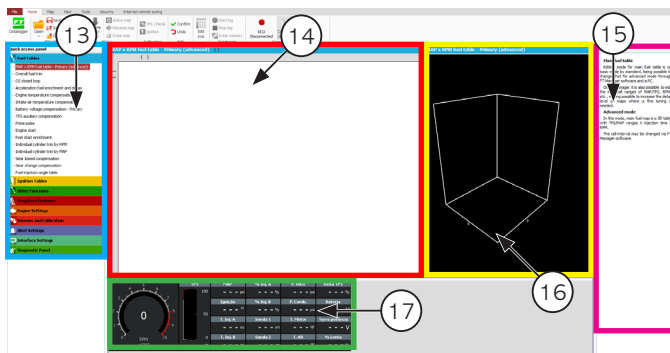

When entering a map or setting up a function, there are some buttons on the screen that act as described below:

- 18 - Red area shows the point selected for edition;
- 19 - Yellow area is shown only when the engine is running and shows the actual condition of MAP, temperature, TPS, etc.;
- 20 - **Button +:** increases the value of the selected parameter;
- 21 - **Button >:** Selected next parameter on the map;
- 22 - **Save/Select Button:** Saves any changes done to the map or configuration and returns to the main menu;
- 23 - **Home Button:** Returns to the home screen. If any maps or configurations we're changed, it asks for confirmation;
- 24 - **Cancel/Back Button:** Cancels all changes done to the maps or configuration and returns to previous menu;
- 25 - **Button -:** Reduces the value of the selected parameter;
- 26 - **Button <:** Selects previous parameter on the map;
- 27 - **Button <>:** Change the screen (if available on the menu);

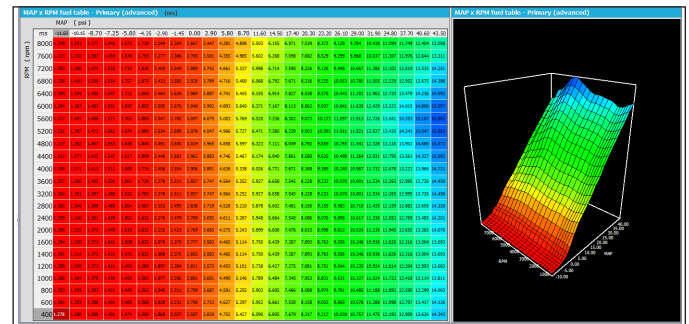
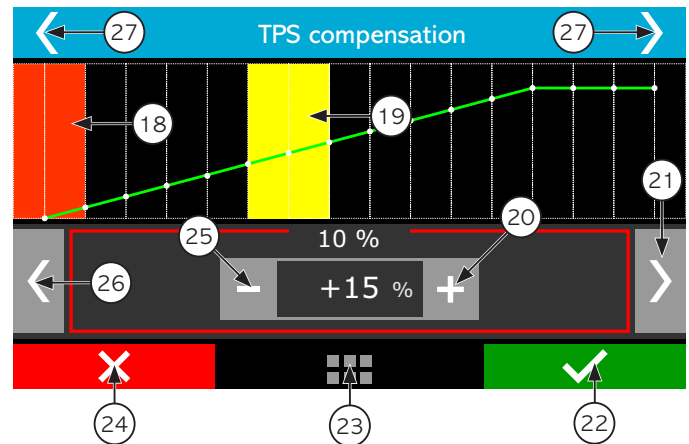

In the FTManager all commands are accessible through mouse and keyboard. The advance (3D) fuel table is shown below:

Advanced edition mode

In the advance mode, both fuel and timing tables will be in a 3D table format. Some functions will also be presented in a 3D table only. The navigation is very simple, in the left bottom corner you can see the current position in the table. Green marker is for bank A and purple for bank B. A yellow marker will show the current engine table position. If you click this icon, you will taken to the current load/tps and rpm position.

To scroll through the vacuum/pressure or TPS, click in the horizontal direction of the table, to RPM ranges, click in the vertical direction.

- 1 - Injector Bank;
- 2 - Engine RPM;
- 3 - MAP / TPS;
- 4 - Use button + and - to increase or decrease injection time;
- 5 - Injection time and percentage. The above value corresponds to bank A value below to bank B;

6 - Table position mini map:

Yellow: click this icon to go directly to the point of the map where the engine is working at the moment;

Purple: That's the position of the table that's being shown by the screen;

	0,60	0,80	1,00
A 3000	2,300	3,080	3,860
B 3500	2,338	15,980 (106%) 3,140 (20%)	3,943
4000	2,388	3,220	4,052

6.3 FTManager shortcuts

- **F1** – Show and hide help panel;
- **F2** - Show and hide quick access panel;
- **F3** – Show and hide graph;
- **F4** – Show and hide real time (FTManager real time dashboard);
- **F5** – display main table and hide every other function;
- **F6** – change the main fuel table measurement unit: milliseconds (ms), volumetric efficiency (%VE), duty cycle (%DC), fuel flow (lb/hr or customized unit)
- **F7, F8, F9, F12** – no shortcut;
- **F10** – datalog overlay - vertical split screen
- **F11** – datalog overlay - horizontal split screen

- **(Ctrl) + (C)** – copy;
- **(Ctrl) + (V)** – paste;
- **(Ctrl) + (+)** – fast value increment. Increases 0,100ms in the fuel table. On VE and DC the change is related to milliseconds;
- **(Ctrl) + (-)** – slow value decrement. Decreases 0,100ms in the fuel table. On VE and DC the change is related to milliseconds
- **(+)** – increment in 0,010ms steps. On VE and DC the change is related to milliseconds
- **(-)** – decrement in 0,010ms steps. On VE and DC the change is related to milliseconds
- **(Shift) + (+)** – slow value increment in 0,001ms steps. On VE and DC the change is related to milliseconds
- **(Shift) + (-)** – slow value decrement in 0,001ms steps. On VE and DC the change is related to milliseconds
- **(A)** – sum;
- **(M)** – multiply;
- **(Space bar)** – pops up a box to fill a value;
- **(I)** – interpolate the selected cells;
- **(V)** – interpolate vertically the selected cells;
- **(H)** – interpolate horizontally the selected values;
- **(S)** – site function. Moves the cursor to actual engine position;
- **(Home)** – moves the cursor to the leftmost cell;
- **(End)** – moves the cursor to the rightmost cell;
- **(Page Up)** – moves the cursor to the topmost cell;
- **(Page Down)** – moves the cursor to the bottommost;

6.4 Dashboard screen

When the engine is running, the dashboard screen shows real-time information of sensors that are being read by the ECU.

Chapter 23.3 has more information on how to change the instruments on this screen.

To access the dashboard screen, touch the icon , located at the main menu.

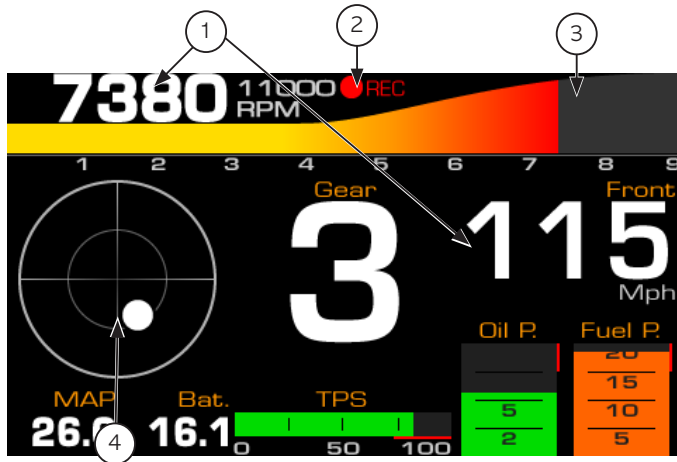

- 1 - Real time readings;
- 2 - Internal datalogger status;
- 3 - Touch this whole area to access the main menu;
- 4 - Accelerometer graphic;

The dashboard is also shown in real time in FTManager:

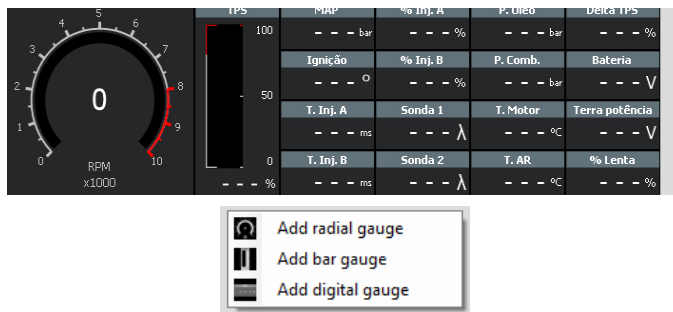

To add or remove gauges, click with mouse right button in a free space and select the gauge type you want to (radial, bar or digital).

6.5 Diagnostic panel

The diagnostic panel is a function which shows all ECU inputs and outputs parameters and is very helpful to detect anomalies in FT600 tune, sensors and actuators. To access it through FTManager, click on Diagnostic Panel tab at quick access panel.

The Diagnostic Panel is a tool used to detect anomalies on FT600 inputs, outputs, sensors and actuators. In order to access it, touch its icon at the main menu.

Information is split on 11 pages:

- Page 1: Diagnostic Crank RPM sensor and Cam RPM sensor;
- Page 2: general engine information;
- Page 3: status of white inputs;
- Page 5: status CAN Communication;
- Page 6: status of blue outputs;
- Page 8: status of gray outputs;
- Page 9: status of yellow outputs;
- Page 10: RPM reading diagnostics;
- Page 11: Test time based feature;

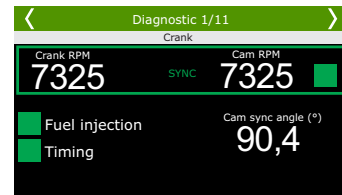

Pages 2 to 9 shows input/output at the left column, position/command sent to the actuator, (outputs)/voltage read (inputs) at the central column and the main information used to calculate the position/command at the right column. For a thermatic fan output, i.e., diagnostic panel shows its status at the center column and the engine coolant temperature at the right column.

On page 10 are information regarding the engine RPM signal readings. Below are some common errors and possible causes:

Crank trigger error: gap detected at the wrong spot - it detected the gap (missing teeth) in the wrong place; it can also happen with a trigger wheel without missing tooth when there is a cam sync signal in the wrong place. Also occurs in engines with a very light flywheel that accelerates and decelerates quickly during compression strokes at engine startup and running.

Crank trigger error: wrong number of teeth - number of teeth is different on the crank trigger wheel than what is set at ECU. Electrical noise can cause a reading of a “ghost” tooth, for example.

Crank trigger error: missed tooth reading - the ECU detected less teeth than it should have. Also happens in engines with a very light flywheel that accelerate and decelerate very fast during compression strokes at engine startup and running.

Crank trigger error: abnormal acceleration - tooth error detection. Usually caused by signal noise.

Cam sync sensor: signal noise - cam sync signal detected in the wrong spot. Typically this error is caused when the ECU detects noise in the cam sync sensor signal or when the cam trigger wheel has more than one tooth.



ATTENTION

When the 2-step and 3-step are set to activate by speed, its operation can be checked through the page 1 of the Diagnostic Panel, not through page 2, since you are not using an analog input (white wire) to switch.

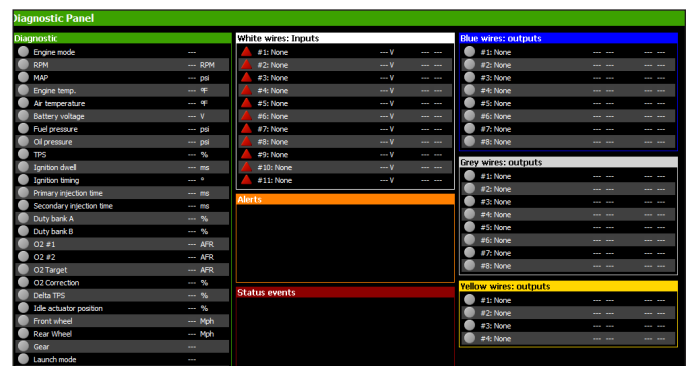

Diagnostic panel labels

Diagnostic 2/6		
White wires: Inputs		
▲ 1: O2 sensor #1	4,994 V	1,10
■ 2: Two-Step	4,995 V	Disab.
■ 3: Air conditioning	0,094 V	Disab.
▲ 4: Oil pressure	4,995 V	9,98 bar
■ 5: Engine temperature	4,509 V	1 °C
▲ 6: Fuel pressure	4,998 V	9,98 bar
■ 7: Air temperature	0,663 V	10 °C
● 8: Available	0,000 V	0
● 9: Available	0,000 V	0
■ 10: MAP	0,021 V	0,84 bar
■ 11: TPS	0,000 V	0,00 %

<input checked="" type="checkbox"/>	Input or output is configured, enabled and working properly.
<input type="checkbox"/>	Input or output is configured and disabled.
<input type="radio"/>	Input or output has not been set up.
<input checked="" type="checkbox"/>	Input or output is set up, but there is an abnormal behavior.

6.6 Test time based features

This menu allows to run the output test controlled by time. To start this test the engine must be turned off and the ignition switch on (12V). The test starts when the 2-step button is pressed and lasts as long as he keeps pushing.

While the test is performed the RPM values, MAP, TPS and temperatures can be changed in real time.

Test time based features

Enable

Hold the 2-step button for the test

Time: 0.00s

Engine RPM: 6000 rpm

MAP: 0.00 psi

TPS: 100.0 %

Air temp.: 104.0 °F

Diagnostic

- Engine mode ---
- RPM --- RPM
- MAP --- psi
- Engine temp. --- °F
- Air temperature --- °F
- TPS --- %
- Ignition timing --- °
- Primary injection time --- ms
- Secondary injection time --- ms
- Duty bank A --- %
- Duty bank B --- %

Blue wires: outputs

- #1: None ---
- #2: None ---
- #3: None ---
- #4: None ---
- #5: None ---
- #6: None ---
- #7: None ---
- #8: None ---

Grey wires: outputs

- #1: None ---
- #2: None ---
- #3: None ---
- #4: None ---
- #5: None ---
- #6: None ---
- #7: None ---
- #8: None ---

Yellow wires: outputs

Test time based features

Desat. Activ.

Hold the 2-step button for the test

Tempo (s): 0,00

RPM 1000 +

MAP 0,00 +

TPS 90,0 +

T.air 70,0 +

T.engine 70,0 +

6.7 Internet Remote Tuning

Since update 3.3, FTManager has a new feature wich will make it easier to connect 2 computers that have FTManager installed.

To Start a connection go to the “Internet Remote Tuning” tab on FTManager.

- **Allow remote tuner:** This option allows for another remote computer to connect to your FTManager. Click on “Allow” to generate a 6 digit password wich must be informed to the tuner that’s going to connect to your computer.

- **Tune remote client:** This option allows you to connect to another remote computer using the 6 digit password generated on the clients FTManager.

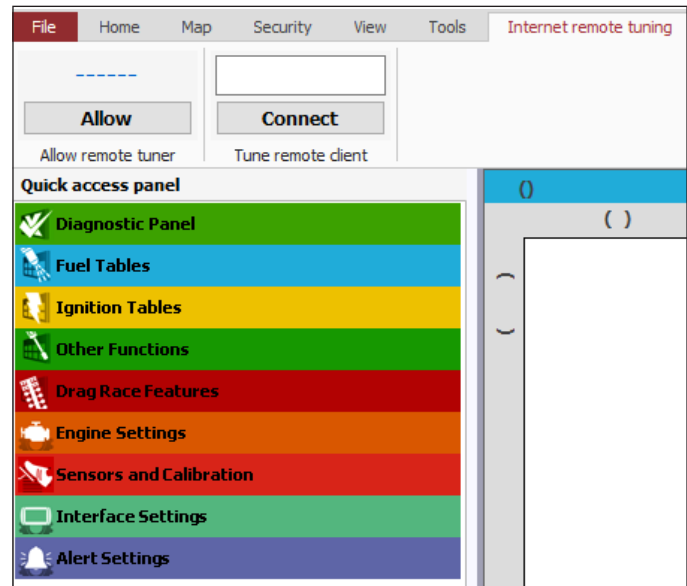

7. Engine settings

FuelTech ECUs leave the factory without maps or adjustments, so you need to create the injection maps, ignition and the inputs and outputs settings before running the engine.

The FuelTech Default is an automatic calculation of the basic injection and ignition maps for your engine based on the information provided in the “Engine Settings”. Performing this automatic adjustment every injection and ignition maps, including temperature compensation, etc. Will be filled based on your engine characteristics.

The information provided must be correct and consistent, maximum RPM and boost values should be according to the engine capacity and the injectors should be properly sized to the estimated engine power.

The use of an instrument, such as oxygen sensor (wideband recommended) and/or an analyzer of exhaust gases, to make the analysis of the air/fuel mixture is extremely important.

Caution, especially in the start-up, is needed, since it is an initial tune that will meet most engines, there are no guarantees for any situation. Be extreme cautious when tuning your engine, never requires high loads before it a good tune.

Start tuning with a rich map and a conservative timing, because starting with a lean map and advanced timing can severely damage the engine.

To create a default map by FTManager, click the “File” menu and then “New” to start the wizard. The menu “Engine Settings” will be passed in sequence.

Check in later chapters the descriptions of all these options required to complete the step by step and create the default map.

To generate a new map through the touchscreen, just get in a setting that is empty and a message appears telling you that the setting is empty and asking if you want to create a new tune.

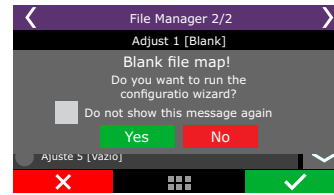

In the first screens of the wizard are the settings for measurement units used by the ECU. Select the temperature, O2 sensor, pressure and speed units.

The following screens are part of the engine configuration menus and are described in the following chapters. Follow the wizard by reading the next pages.

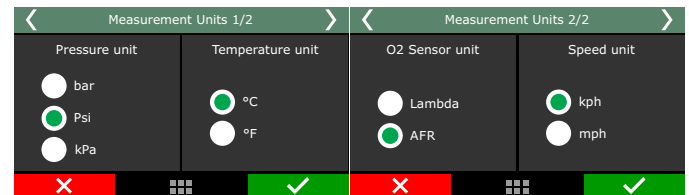

7.1 Engine setup

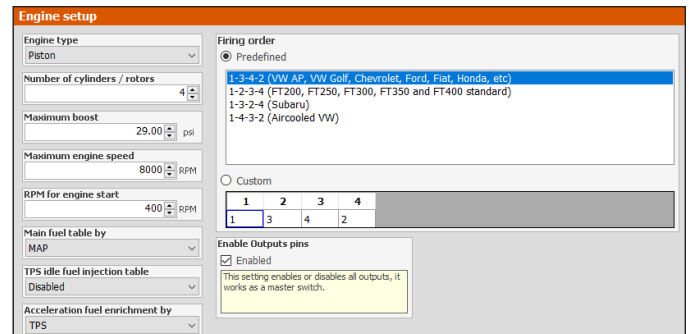

Enable outputs

Basically prevents the outputs from turning on (injection, ignition and auxiliary outputs).

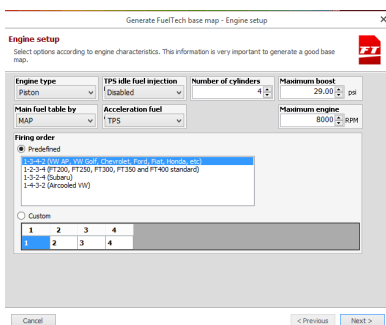
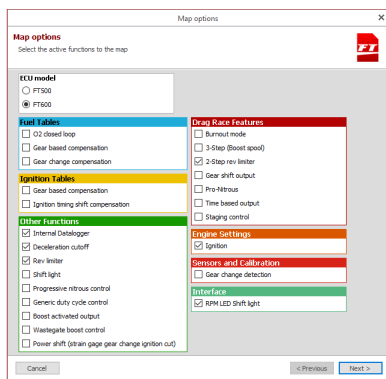
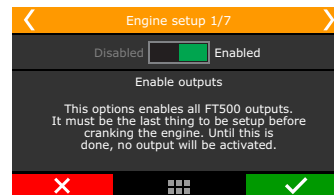

Engine type and number of cylinders

Select the type of engine, piston or rotary and the number of cylinders or rotors.

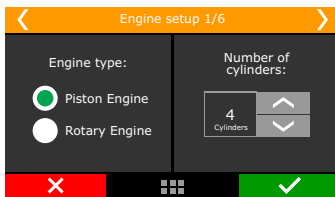

Engine limits

Setup the maximum RPM and maximum boost.

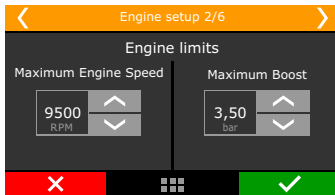

Maximum engine speed: setup the engine maximum RPM. All fuel and timing maps will be created with its last point on this RPM. This parameter is also used to calculate fuel injector's percentage of use.

Maximum boost: maximum boost for fuel and ignition maps. For naturally aspirated engines, set this option as 0.0 psi. For turbocharged engines, use 1Psi above the maximum boost the engine will effectively be using. In case of an overboost, the ECU will apply the last injection timing set on the map. This option doesn't control boost pressure, is just a limit for fuel and ignition maps.

Firing Order

Select the firing order according to your engine.

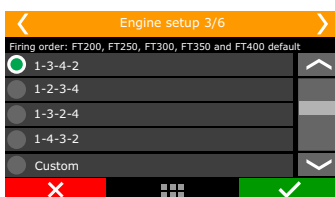

4 cylinder engines

- 1-3-4-2: majority of engines, VW AP, VW Golf, Chevrolet, Ford, Fiat, Honda, etc.;
- 1-3-2-4: Subaru;
- 1-4-3-2: air-cooled VW;
- 1-2-4-3: Motorcycles (majority)

5 cylinder engines

- 1-2-4-5-3: Audi 5 cylinders, Fiat Marea 20V and VW Jetta 2.5;

6 cylinder engines:

- 1-5-3-6-2-4: GM in line (Opala and Omega), VW VR6 and BMW in line;
- 1-6-5-4-3-2: GM V6 (S10/Blazer 4.3);
- 1-4-2-5-3-6: Ford Ranger V6;

8 cylinder engines:

- 1-8-4-3-6-5-7-2: Chevrolet V8 (majority);
- 1-8-7-2-6-2-4-3: Chevrolet LS
- 1-5-4-2-6-3-7-8: Ford 272, 292, 302, 355, 390, 429, 460;
- 1-3-7-2-6-5-4-8: Ford 351, 400 and Porsche 928;
- 1-5-4-8-6-3-7-2: Mercedes-Benz;

10 cylinder engines

- 1-10-9-4-3-6-5-8-7-2: Dodge V10;
- 1-6-5-10-2-7-3-8-4-9: BMW S85, Ford V10, Audi, Lamborghini V10;

12 cylinder engines

- 1-12-5-8-3-10-6-7-2-11-4-9: Jaguar V12, Audi, VW, Bentley Spyker W12;
- 1-7-5-11-3-9-6-12-2-8-4-10: 2001 Ferrari 456M GT V12;
- 1-7-4-10-2-8-6-12-3-9-5-11: 1997 Lamborghini Diablo VT;

Customized

- In case the firing order of your engine is not listed on the ECU, there's a mode that allows full customization of the firing order.

Main fuel table

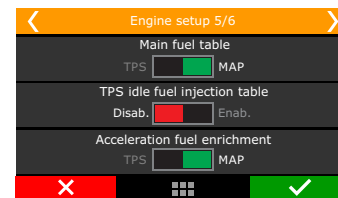

MAP: this mode is indicated for turbo or naturally aspirated engines. That's the mode that better represents engine load, because engine vacuum varies under different loads, even with the throttle on the same position.

TPS: this option is mostly used on naturally aspirated engines with aggressive camshafts, when this causes the vacuum on idle and under low load conditions to be unstable. When this option is selected, MAP compensation is available for fuel and timing maps.

TPS idle fuel injection table: This is the mode the fuel injection on idle speed will be controlled. When enabled, a table that relates injection time versus engine RPM is activated whenever TPS is equal to 0%. Enable this feature on engines with high profile camshafts and unstable vacuum on idle.

For street cars with stable vacuum on idle, it is recommended to keep this feature disabled. In this case, injection time for idle will be set up directly on the vacuum ranges on the main fuel MAP.

Accel fuel enrichment: use this parameter set up as TPS always when possible, as this sensor is faster than the MAP sensor to indicate a quick change of position in the throttle.

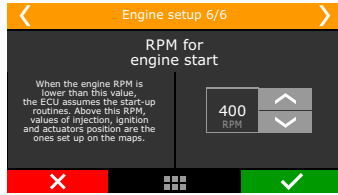

RPM for engine start: set up a RPM limit above which the start-up routines are disabled. Below this RPM, all the injection, ignition and actuator positions set up for engine start are used.

7.2 RPM signal

RPM signal is the most important information to run the engine properly. This menu is where the RPM input will be set up.

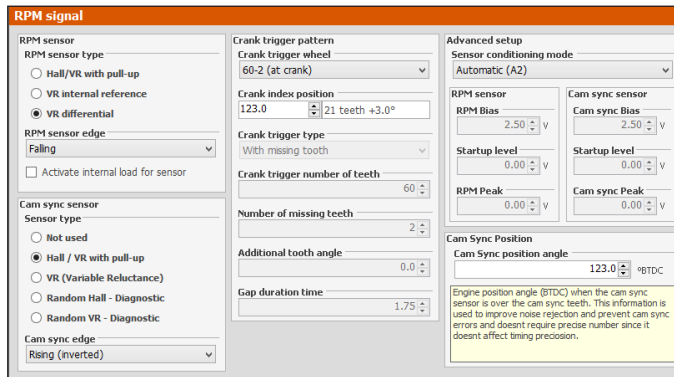
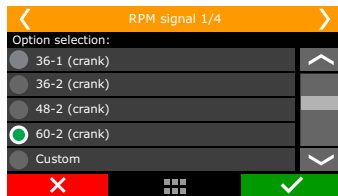

Engines with crank trigger: select the crank trigger pattern.

Select the crank trigger or distributor pattern. In case of a crank trigger without missing tooth and multi-coils, a cam sync sensor is required. When using a single coil, the cam sync sensor is not mandatory. A several options of standard patterns are available for using with multi-coils or distributor based systems.

RPM Sensor

Select the RPM sensor used on the vehicle, VR or Hall Effect.

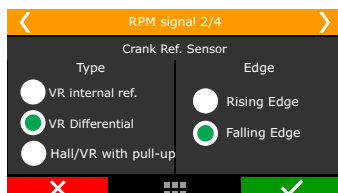

VR internal ref: Only use this option when told by our tech support. This is used for compatibility with older units only.

VR Differential: Select this for VR sensors; it's less susceptible to electromagnetic interference. When the crank trigger signal is splited with the OEM ECU this option is mandatory.

Hall/VR with pull-up: Select when using Hall effect RPM sensor or when experiencing problems with electromagnetic interference.

RPM Signal Edge: this option changes the way the ECU reads the RPM signal. As there's no simple way of telling which one is the correct option (without an oscilloscope), select the option Standard (Falling Edge). If the ECU sees no RPM signal during initial startup, change this parameter to Inverted (Rising Edge)

First tooth alignment: set here the crank trigger alignment related to the TDC. This alignment can be checked by turning the engine to the cylinder #1 TDC and counting, counterclockwise, angle distance, from the crank trigger gap to the RPM sensor. If there crank trigger has no gap, the angle distance is from the previous teeth to the RPM sensor.

For engines with distributor and Crank trigger, check our Technical Support for information about the alignment in use.

Below is a table with known alignment values and configurations for most of the cases:

Crank trigger - pattern	Engine/brand	Recommended index position	Cam sync sensor
60-2	BMW, Fiat, Ford (inj. Marelli), Renault, VW, GM	123° (GM) 90° (others)	Not mandatory
48-2			Not mandatory
36-1	Ford (ECU FIC)	90°	Not mandatory
36-2-2-2	Subaru	55°	Not mandatory
36-2	Toyota	102°	Not mandatory
30-1			Not mandatory
30-2			Not mandatory
24-1	Hayabusa	110°	Not mandatory
24-2	Suzuki Srad 1000		Not mandatory
24 (crank) or 48 (cam)		60°	Falling edge
15-2	bikes Honda CB300R		Not mandatory
12+1	Honda Civic Si	210° or 330°	Not mandatory
12-1	bikes Honda/Suzuki/Yamaha		Not mandatory
12-2			Not mandatory
12 (crank) or 24 (cam)	Motorcycles/AEM EPM/ Honda distributors 92/95-96/00		Falling edge
8 (crank) or 16 (cam)			Falling edge
4+1 (crank)			Not mandatory
4 (crank) or 8 (cam)	8 cylinders	70°	Falling edge
3 (crank) or 6 (cam)	6 cylinders	60°	Falling edge
2 (crank) or 4 (cam)	4 cylinders	90°	Falling edge



WARNING:
Ignition calibration values on this table are just a start point. ALWAYS perform the ignition calibration according to chapter 16. When the ignition is not correctly calibrated, the timing shown on the ECU screen is different from the one that is being applied to the engine. This may cause serious damage to the engine.

Cam sync sensor

This option indicates if a cam sync sensor will be used and if it uses a hall effect or magnetic variable reluctance (VR) sensor. This sensor is mandatory when controlling fuel or timing in sequential mode. Without cam sync sensor the injection mode will be only semi-sequential or multipoint. Ignition will be always wasted spark.

Random cam sync sensor option is a test mode that automatically assumes a position for the cam sync signal. Use this only for testing purposes, as this may cause misfires in some applications. Use this option only for tests, because with individual coils and sequential ignition the firing order can be lagged (inverted) in 360°, so the engine won't start.

Cam sync sensor edge: this option changes the way the ECU reads the cam sync signal. As there's no simple way of telling which one is the correct option (without an oscilloscope), select the option Falling edge. If the engine starts with misfires, change this parameter to Rising edge.

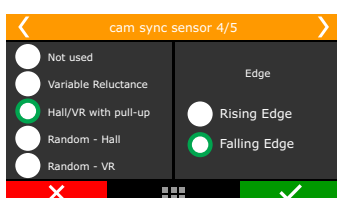

Cam sync sensor for synchronization

Cam sync signal will be used only for 10 revolutions after engine start and after that will be disregarded for engine synchronization but it will still be recorded on the datalogger.

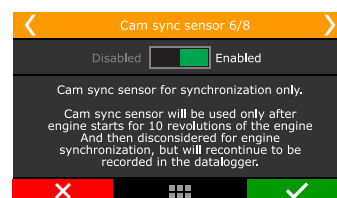

Cam sync position angle

The adjustment is degrees before top dead center (°BTDC) of cylinder 1 combustion.

This angle is not mandatory and won't affect the ignition calibration. If you don't know the position angle, set the same alignment as crank index position or select the cam sync sensor as random.

With the random mode enabled, the position angle in the log and diagnostic panel.

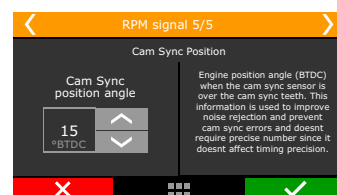

Cam sync position

Cam sync position is used to create a range within which a Cam sync signal is read and all others out of it are discarded, allowing the use of a single reference on multi-toothed Cam sync pulleys.

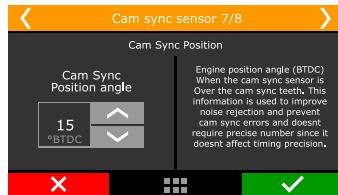

The option "distributor" means that the spark distribution will actually be done by a distributor, with a single coil, regardless of the number of cylinders. Only the ignition output #1 (gray #1) will be used to control the ignition coil, the others are disabled.

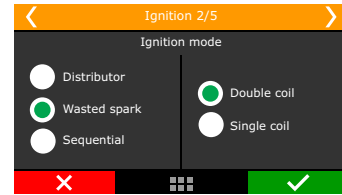

7.3 Ignition

This menu sets everything related to the ignition control mode and there is a "Default" mode (configurable through the ECU or PC) and a "Custom" mode (configurable only through the PC). When the ignition is set as "Disabled", timing maps are unavailable and only the fuel control is enabled. Gray outputs are free to be set up as injectors or auxiliary outputs.

Default: this mode makes available the options that are commonly used for the majority of engines, with standard firing order tables and configurations.

Custom: this mode enables all the options related to the ignition control, as customizable firing orders and angles, etc. When using this mode, ignition configuration can only be done through a PC with FTManager Software.

FTSPARK

Select the FTSPARK check box when using the fueltech FTSPARK module and select the connection mode with it:

Multiple outputs: this is the conventional way of connecting FT to any ignition module, using an ignition output to trigger each coil (double or single). In this case one or more ignition outputs will be connected to the FTSPARK.

FTIgnition BUS (one multiplex output): Select this option to enable only one ignition output to send all the ignition trigger signals to the FTSPARK via the FT Ignition BUS. In this way the other outputs that would be used for ignition can be reallocated to other functions.

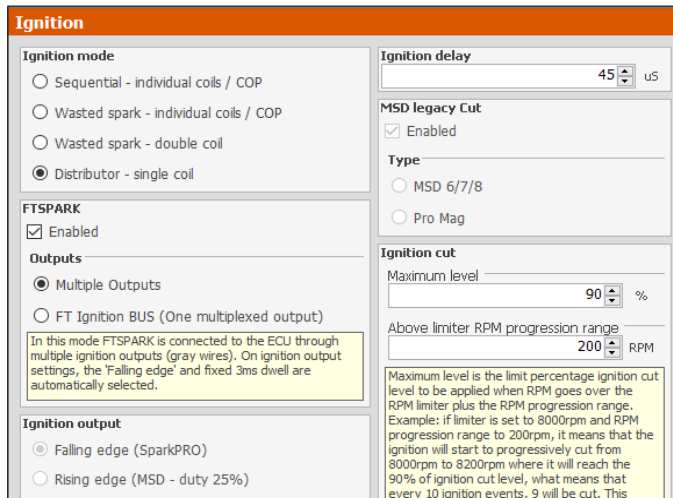
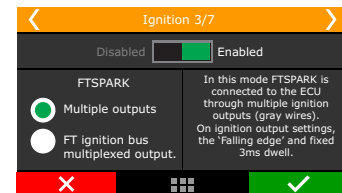

Output Test

When the multiplexed output is selected, its possible to test the FTSPARK outputs using a "test function" on the FTManager. To do so, go to 'Sensors and Calibration' then 'Outputs' and select FTSPARK - Output test.

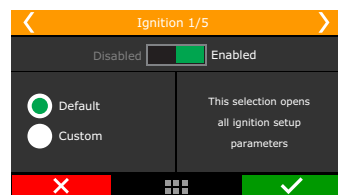
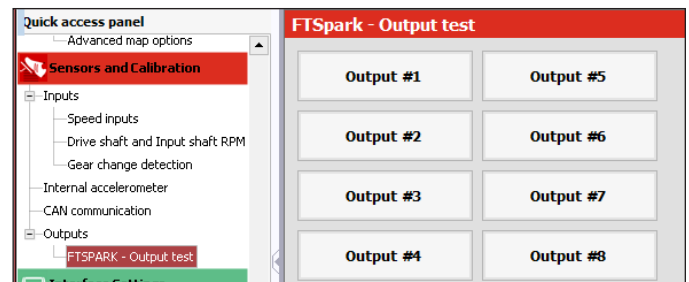

Ignition Mode

Select if the ignition will be controlled in sequential (cam sync sensor needed) or wasted spark modes or if a distributor will be used for that control. There is also the wasted spark mode, where the coils work in pairs.

Ignition output

Select the ignition output edge/mode.

Falling edge (SparkPRO): Select this option when using FuelTech SparkPRO, M&W ignition, smart coils (integrated igniter, such as GM LS coils). This mode has dwell control enabled. It's important to know the dwell requirements or "charge time" of your particular ignition coil(s).

• **Rising edge (MSD duty 50%):** select this option when using MSD, Crane, Mallory or other capacitive discharge ignitions (CDI). This mode has a fixed 50% duty cycle signal.

• **Rising edge (Honda Distributor):** this option must only be selected when using Honda distributor with stock igniter (the one that's integrated to the distributor). This mode has dwell control enabled. Select this option only when using Honda OEM igniter and distributor.

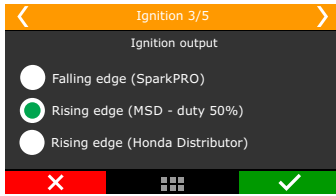

Ignition cut

The ignition cut maximum level is the percentage of ignition events that will be cut to limit the engine RPM.

The RPM progression range acts like a smoothing for the ignition cut. Example: rev limiter at 8000rpm, RPM progression range at 200rpm. From 8000rpm the ignition cut level will gradually increase until it reaches 90% cut at 8200rpm.

Percentages less than 90% may not keep the engine under the rev limiter. Bigger RPM progression range tend to stabilize more smoothly the rev limiter, but allows the RPM to pass the RPM set as rev limiter.

These numbers are valid to all kinds of ignition cut, with the exception of time based compensations (time based RPM and driveshaft RPM/wheel speed) and 2-step. These features have their own parameters. For inductive ignition systems it is recommended to use 90% maximum level and 200 RPM progression range. For capacitive system, like MSD, it is recommended to use 100% maximum level and 1 RPM progression range.

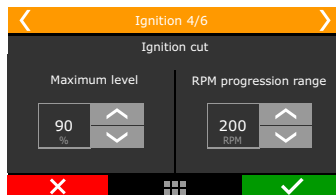

External cut

This mode is only available when using a distributor and a MSD ignition module. Enabling this option means the ignition cuts will be performed by the MSD using the Legacy input they have.

To use MSD Legacy cut a FT600 white wire has to be connected to the MSD Legacy right pin. By standard, White#10 is setup as ignition cut.

When experiencing problems with the cut through MSD like no cut at all or RPM limit always 500 RPM above what was setup, use the other MSD pin.

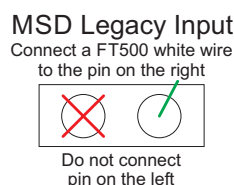
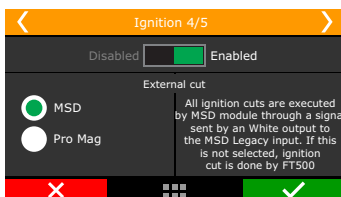

Ignition Delay time

That's the delay time the ignition module has between receiving a signal to spark and effectively spark at the plugs. Time is given in microseconds (uS).

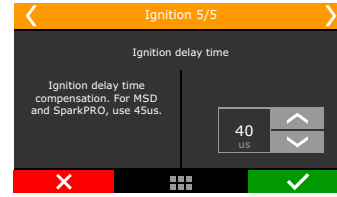

7.4 Fuel injection

In this menu, all the options related to fuel settings must be configured.

Basic: This mode makes available the options that are commonly used for the majority of engines, with standard injection angles and configurations.

Advanced: This mode enables all the options related to the fuel control, as customizable injection angles, etc. When using this mode, fuel injection configuration can only be done through a PC with FTManager Software. It is also possible to customize all the fuel tables and RPM positions, adding RPM, TPS or MAP points according to the engine needs

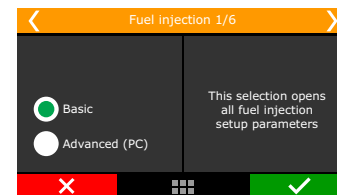
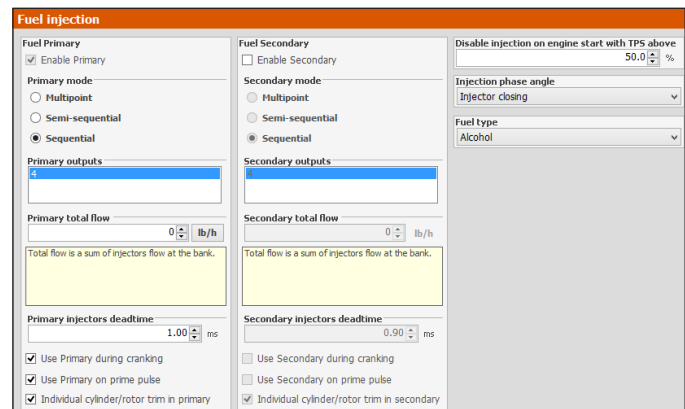

Fuel Banks: select primary and secondary (if used) banks control mode.

Multipoint: All the injector's outputs will fire at the same time, as batch fire.

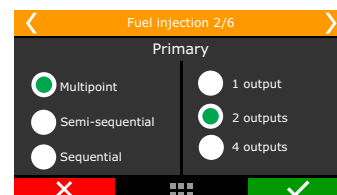

Semi-sequential: in this mode, injectors are fired once per engine revolution, at 0° and 360°, in pairs, according to the twin cylinders. In a 4 cylinder engine, cylinders 1 and 4 will be fired at the same time, then cylinders 2 and 3 at the same time.

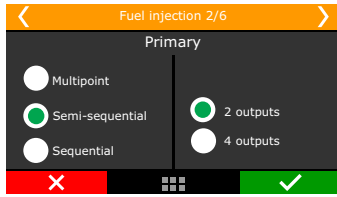

Sequential: in this mode, each injector output fires only a single time per engine cycle (720° on a 4 stroke). This mode is only available when a cam sync sensor is properly set up.

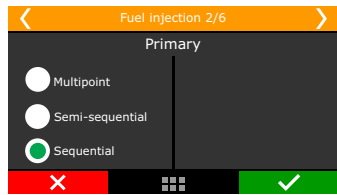

Injector's total flow

That's the total flow of all injectors on the bank (primary or secondary). This data is used to allow addition of some fuel tables in lb/hr i.e. four 80 lb/hr injectors on primary bank have a total flow of 320 lb/hr (80 x 4).

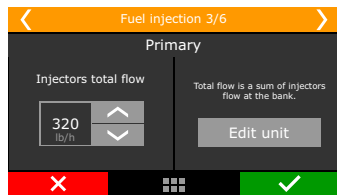

Fuel type

Select the fuel used on the motor. This information is used to create a better base map

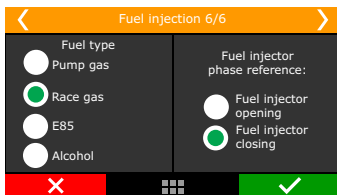

Fuel injection phase reference

Select if the Fuel injection phase angle table will be based on the injectors opening or closing. The angular distance is the measure between the ignition TDC of each cylinder and the moment the injector should open or close

Fuel injector opening: in this option it is only possible to know the angle the injector will open, but, its closure will vary according to injection time and RPM, this means that, depending on these factors, the fuel injection may still be occurring even after the intake valve has closed

Fuel injector closing (default): This is the most commonly used option as the fuel injection always occurs before the end of the intake cycle, no matter the injection time or RPM.

7.5 Pedal/Throttle

Select the option "TPS" when using a mechanical throttle, driven by cable.

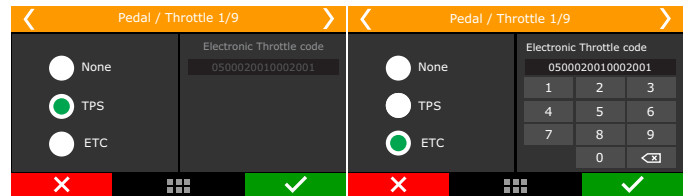
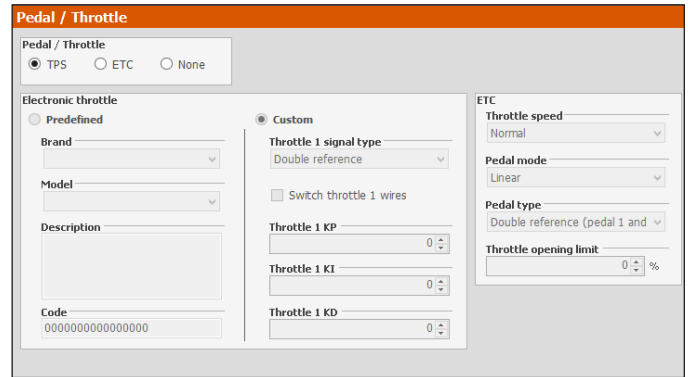

TPS

When using a throttle drives by cable with a potentiometer on the throttle shaft select the TPS option.

Standard input for TPS sensor signal is #11, but it is possible to set this input on any available input. Pedal/Throttle calibration must be performed as shown in chapter 12.4

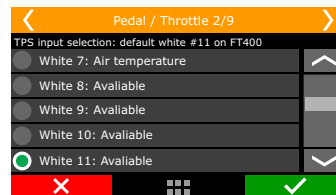

Electronic throttle control ETC

First data to be inserted on the ECU when using electronic Throttle is its code (not the throttle part number). This code is found on the FTManager Software. If your throttle is not on the list, please, contact our tech support to check compatibility first.

Throttle position sensor input

If the map is generated in the FTManager software the ETC inputs will be automatically allocated and can be checked in "Sensors and Calibration" menu, then "Inputs".

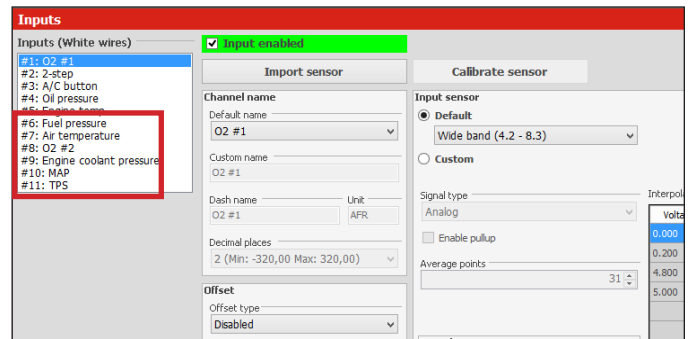

After inserting the Throttle code, set the input that will be connected to the throttle position sensor, usually there are two signals on the throttle. Standard inputs are wires white #11 (Throttle signal #1A) and white #10 (Throttle signal #1B).

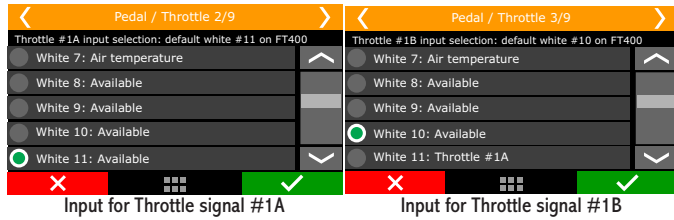

Now, setup the inputs that will be connected pedal #1 and pedal #2 position sensors. The standard inputs are wires white #9 (pedal #1) and white #8 (pedal #2).

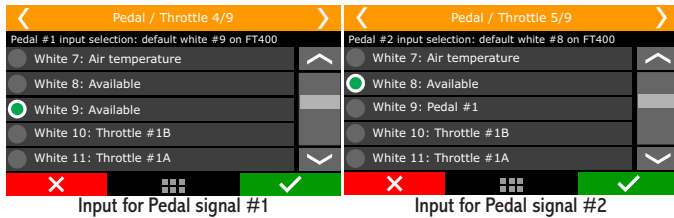

Electronic throttle control motor outputs

When generating the map in the FTManager the Yellow #3 and #4 will be selected to ECT motor control.

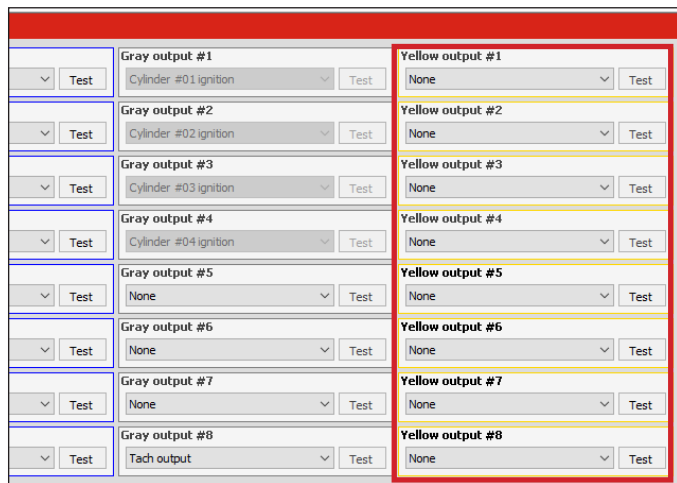

Select the outputs that will control the two wires from the throttle motor. By standard they are yellow #3 (motor 1A) and yellow #4 (motor 1B). In case these outputs are already being used by another kind of control, use outputs yellow #1 and yellow #2

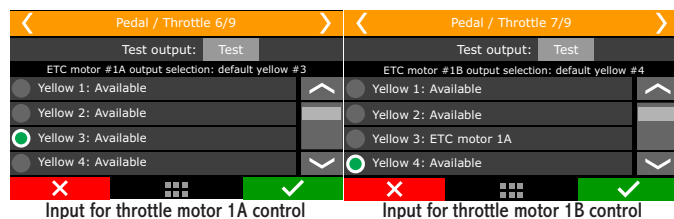

The next parameter to be setup is the Throttle speed.

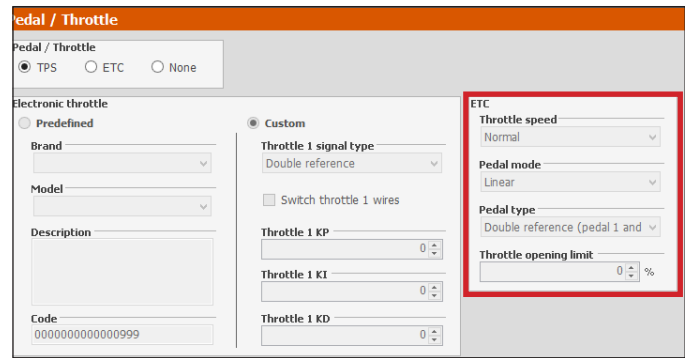

There are five control modes:

Normal: normal throttle response little bit faster than the stock ECU.

Fast: fast throttle response.

Smooth: smoother control mode, used on street cars and automatic transmissions.

Smooth when cold and normal when hot: changes the control mode according to the engine temperature, starts with smooth mode, and then changes to normal mode automatically.

Smooth when cold and fast when hot: changes the control mode according to the engine temperature, starts with smooth mode, and then changes to normal mode automatically

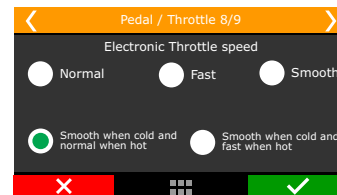

Operation mode: this parameter changes the ratio between the pedal and the throttle.

Linear: this mode has a 1:1 ratio between pedal and throttle.

Progressive: recommended for street cars.

Aggressive: throttle/pedal ratio is 2:1. When pressing 50% pedal, throttle is already on 100%.

The last parameter to be configured is an opening limiter, very useful to limit the engine power by the throttle.

Use 100% when no safety limit is wanted.

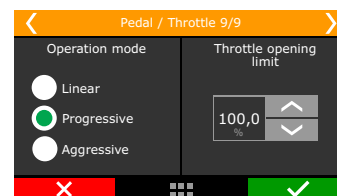

7.6 Idle actuators

This menu allows you to select the idle actuator used on the engine and the outputs that will control it. After this quick setup, the idle speed parameters must be done according to chapter 19.2.

An important tip is that, when selecting “No Actuator”, it is still possible to control idle speed by ignition timing as configured in the “Other Functions” then “Idle Speed” menus. If any kind of actuator is selected, the idle speed by timing control is automatically enabled. This happens because the idle speed control was specially developed for this FT600 , integrating the timing control with the actuator reactions

Electronic throttle

Select this option, then go to “Idle speed control settings”, under “Other Functions” menu.

Check Chapter 19.2 of this manual for more details.

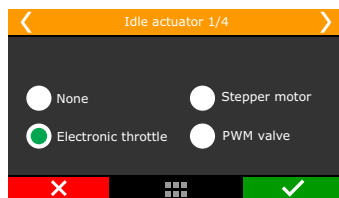
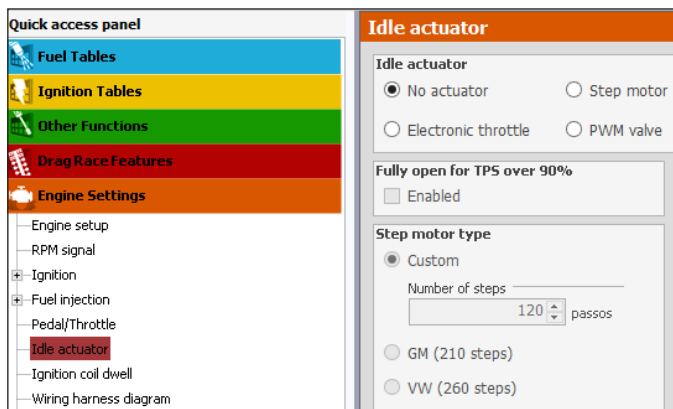

PWM Valve

After selecting this option, it will be necessary to set up the output connected to the valve and the control frequency. Small valves usually use up to 2000Hz. For big valves use around 100Hz. If your valve becomes noisy, that means the control frequency is lower than what the valve requires. In this case, increase the control frequency.

Be aware that the only outputs that can control these kinds of valves are the yellow ones.

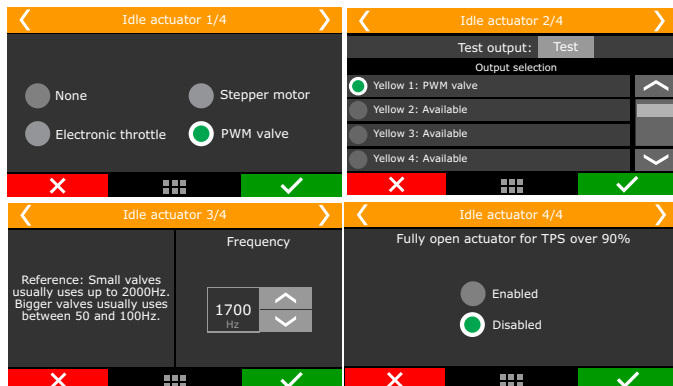

Stepper motor

In this option, the four yellow outputs are used. It is necessary to inform which output controls which step motor output and the step motor type. There are predefined actuators for VW and GM models (number of steps) and a “Custom” mode that allows the configuration of steps. As there are many variables in the manufacturing process, if you’re experiencing difficulties at idle tuning, check the “Custom” mode and change the number of steps. In some GM step motors, 190 is the correct number. For some VW step motors, 210 works better. The option “Fully open for TPS over 90%” fully opens the idle valve when TPS is above 90%, increasing the air admitted.

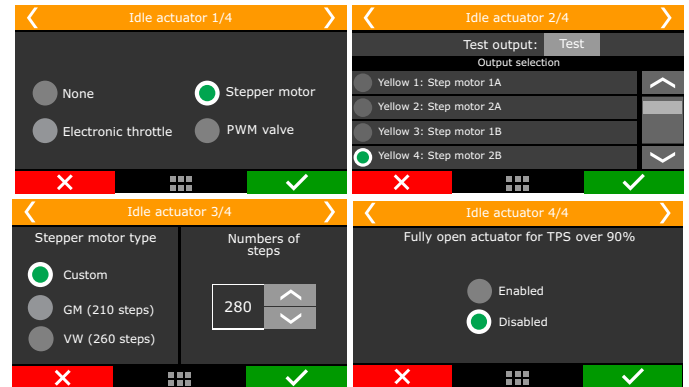

7.7 FuelTech base map

With the “Engine Setup” menu fully set up, the next step is to generate the FuelTech base map, a function that generates fuel and ignition maps to be used as a start point for the engine tuning.

The window below is displayed at the end of configuration assistant in the FTManager:

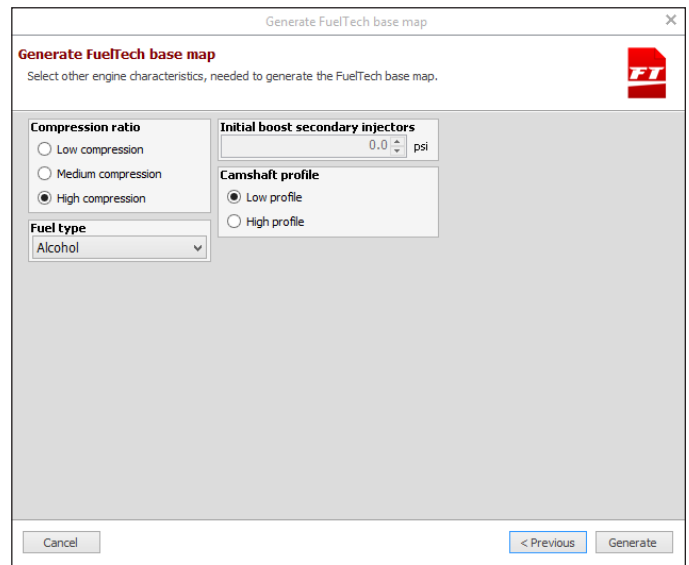

When generating a base map in the touchscreen interface, the informations are displayed as the follow images:

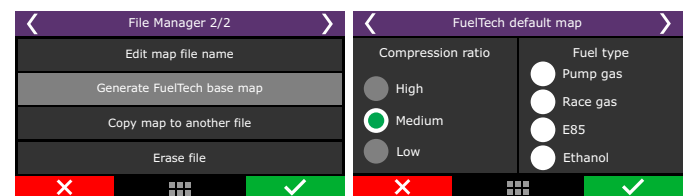

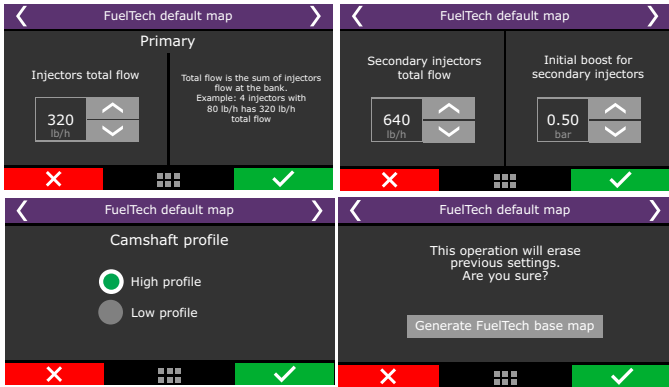

Compression ratio: used to correctly estimate the timing tables. A low, medium or high compression ratio is defined according to the fuel used on the engine and if it is turbocharged or naturally aspirated. I.e., a 10:1 compression ratio for a naturally aspirated engine using ethanol is considered a “low compression ratio”. The same ratio for a turbocharged engine running gasoline will be “high”.

Primary and secondary injector’s total flow: select the flow of the injectors responsible for the naturally aspirated/low load range of the engine.

Initial boost for secondary injectors: set here the pressure you want the secondary bank to start opening, usually under boost. This option is only shown when using two banks of injectors

Camshaft: select the characteristic of the engine camshaft. When selecting high profile camshaft, all injection tables from absolute vacuum until -4.3psi are equal, as this type of camshaft does not have steady vacuum at idle speed. When selecting low profile camshaft, the injection times at vacuum phase are filled up in a linear manner.

Now, click the button “Generate FuelTech base map”. The ECU will show a warning that the current map will be overwritten by the FuelTech base map.

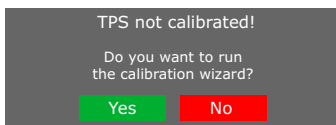

A notice about throttle/pedal calibration will be displayed. Click Yes and you will be redirected to the calibration screen.

The Chapter 15.1 has detailed information about the calibration. The next chapters explain other functions contained in the Engine Settings menu.

7.8 Fuel injectors deadtime

All fuel injectors, as they are electromechanical valves, have an opening inertia, which means that there is a “dead time”, a moment in which the injector has already received an opening signal, but still has not started to inject fuel. This parameter considers, as a standard value, 1.00ms for high impedance fuel injectors. For low impedance injectors using Peak and Hold driver, set the deadtime to 0.60ms. These are

general values; check this parameter with the injector manufacturer. In the FTManager, this parameter is in the Injection menu in “Engine Settings”.

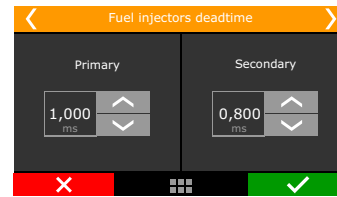

7.9 Ignition Dwell

This option sets the ignition coil charging time. There is a dwell table because the charging time varies according to the battery voltage, especially in vehicles that do not have alternator.

Usually, the lower the voltage, the higher the dwell time has to be set.

Smart coils (coils with internal igniter) demand lower charging times. These are general values; check this parameter with the coil manufacturer.



WARNING:
When using MSD ignition modules, it’s not possible to control the Dwell time. In this case, the coil’s charging time is calculated by th MSD module.

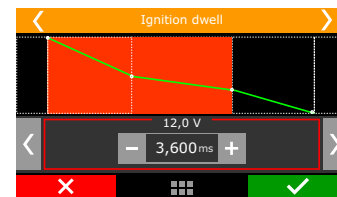
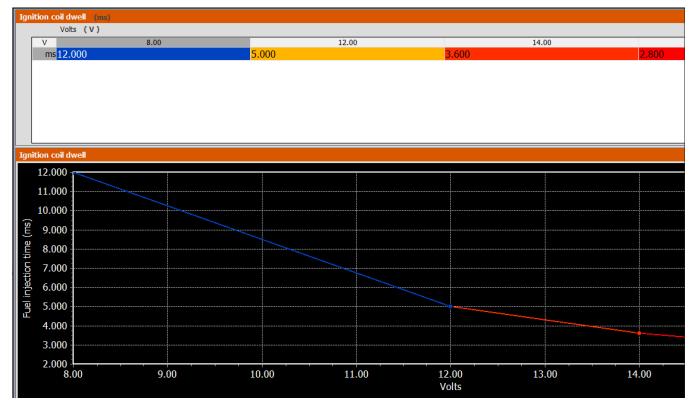

7.10 Ignition energy

This menu allows the user to program the ignition energy of the FuelTech FTSPARK ignition module.

This 3D table relates engine RPM, MAP (boost/vacuum) and the desired mj (milijoules) value.

The ignition energy control is done by connecting both equipments (FT ECU and FTSPARK) by their CAN network.



7.11 Map options

Select the ECU model that is connected to the PC and which features will remain visible on the active map.

This makes navigation through the software much easier by hiding unused menus.

In case you need to make an option visible again, just go to Engine Settings and then Map Options.

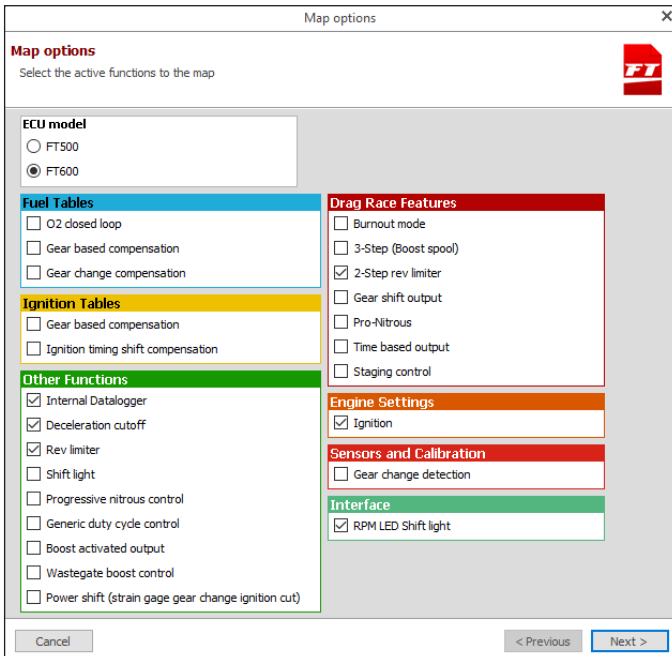

7.12 Advanced map options

There are some options that are only available through FTManager. To access them, go to "Engine Settings" Menu:

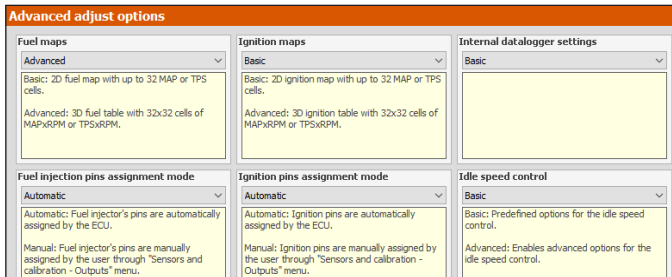

Injection

Fuel maps

- Basic - fuel maps are in a 2D table that relates MAP x injection time or TPS x injection time.
- Advanced - 3D MAP x RPM or TPS x RPM fuel table with 32x32 cells.

Fuel injection pins assignment mode

- Automatic - fuel injector's pins are automatically assigned by the ECU.
- Manual - fuel injector's pins are manually assigned by the user through "Sensors and Calibration - Outputs" menu.

O2 closed loop mode

- Basic - Predefined options for the O2 closed loop.
- Advanced - Enables advanced options for the O2 closed loop.

Ignition

Ignition maps

- Basic - ignition maps are in a 2D table that relates MAP x timing or TPS x timing.
- Advanced - 3D MAP x RPM or TPS x RPM timing table with 32x32 cells.

Ignition pins assignment mode

- Automatic - ignition pins are automatically assigned by the ECU.
- Manual - ignition pins are manually assigned by the user through "Sensors and Calibration - Outputs" menu.

RPM settings

- Basic - Pre-defined voltage detection levels for VR crank and cam sensors.
- Advanced - The adjustment of voltage levels for detection of VR sensors in advanced mode allows the conditioning of non standard crank/cam signals, especially when they're spliced with the stock ECU.

Other Function

Internal Datalogger

- Basic: fixed sampling rates.
- Advanced: configured sampling rates per channel.

Idle speed control

- Basic - predefined options for controlling idle. Meet 99% of the vehicles.
- Advanced - releases advanced options such as PID control, target approach RPM, deadband, approach RPM, etc.

Wastegate boost pressure control

- Basic - predefined options for the wastegate boost pressure control.
- Advanced - enables advanced options for the wastegate boost pressure control.

8. Electrical installation

As FT600 wires are fully configurable according to the installation needs, it is very important that the step by step guide shown on chapter 5 is followed before starting the electrical installation. This way the wiring harness connection table is automatically filled as shows the example below:

In the FTManager, to check all the inputs and outputs, go to “Sensors and Calibration” menu, then “Inputs” or “Wiring harness diagram”.

Outputs			
Blue output #1 Fuel injection cyl. #01 - Primary	Blue output #9 None	Gray output #1 Cylinder #01 ignition	Yellow output #1 None
Blue output #2 Fuel injection cyl. #02 - Primary	Blue output #10 None	Gray output #2 Cylinder #02 ignition	Yellow output #2 None
Blue output #3 Fuel injection cyl. #03 - Primary	Blue output #11 None	Gray output #3 Cylinder #03 ignition	Yellow output #3 None
Blue output #4 Fuel injection cyl. #04 - Primary	Blue output #12 None	Gray output #4 Cylinder #04 ignition	Yellow output #4 None
Blue output #5 None	Blue output #13 None	Gray output #5 None	Yellow output #5 None
Blue output #6 None	Blue output #14 None	Gray output #6 None	Yellow output #6 None
Blue output #7 Thematic fan #1	Blue output #15 None	Gray output #7 None	Yellow output #7 None
Blue output #8 Fuel pump	Blue output #16 None	Gray output #8 Flash output	Yellow output #8 None

Through the touchscreen interface, you can access this function in the “Engine Settings”, then “Wiring harness diagram”.

Wiring harness diagram		Wiring harness diagram	
White 1: O2 sensor #1		White 11: TPS	
White 2: 2-step		Blue 1: Primary fuel inj. - cylinder 1	
White 3: Air conditioning		Blue 2: Primary fuel inj. - cylinder 2	
White 4: Oil pressure		Blue 3: Primary fuel inj. - cylinder 3	
White 5: Engine temperature		Blue 4: Primary fuel inj. - cylinder 4	
✗	✓	✗	✓
Wiring harness diagram		Wiring harness diagram	
Blue 8: Shift Alert		Grey 8: Tachometer output	
Grey 1: Ignition - cylinder 1		Yellow 1: PWM valve	
Grey 2: Ignition - cylinder 2		Yellow 2: Fuel pump	
Grey 3: Ignition - cylinder 3		Yellow 3: Electric fan #1	
Grey 4: Ignition - cylinder 4		Yellow 4: Available	
✗	✓	✗	✓

Based on this information, you can start the electrical installation that must be done with the ECU disconnected from the harness and the battery disconnected from the vehicle. It is very important that the cable length is the shortest as possible and that exceeding unused parts of wires are cut off.

Choose an appropriate location to affix the module inside the car, and avoid passing the cable wires close to the ignition wires and cables, ignition coils and other sources of electric noise.

DON'T EVER, under any circumstance, install the ECU near ignition modules in order to avoid the risk of interferences.

Electric cables must be protected from contact with sharp edges on the vehicle's body that might damage the wires and cause short circuit. Be particularly attentive to wires passing through holes, and use rubber grommets/protectors or any other kind of protective material to prevent any damage to the wires. At the engine compartment, pass the wires through places where they will not be subject to excessive heat and will not obstruct any mobile parts in the engine.

Red wire - 12V input

Being the 12V input to FuelTech ECU, this wire must be connected to 12V from a relay (Main Relay) and cannot be shared with the positive wire that powers coils, fuel injectors or other actuators.

• **12V for sensors:** use a 24 AWG wire from the same 12V wire that feeds the ECU (Main Relay). Example: Hall Effect sensors, pressure sensors, speed/RPM sensors, etc. This wire cannot be shared with the positive wire that powers coils, fuel injectors or other actuators.

• **12V for fuel injectors:** use a 14 AWG wire connected to a 40A relay. Protection fuse must be chosen according to the peak current of the fuel injectors plus a 40% safety coefficient.

Example: for up to 4 injectors that draw 1A of current per injector on primary bank, and 4 injectors that draw 4A of current per injector on secondary bank: $(4 \times 1A) + (4 \times 4A) = 20A + 40\% = 28A$. Use a **30A fuse**.

• **12V for coils, fuel pump and other high power actuators:** use a wire with at least 14 AWG connected to a relay and a fuse correctly dimensioned according to the actuator current draw. When using individual coils (COP), it is recommended a 70A or 80A relay.

NEVER share the 12V that feeds injectors, coils or other accessories, because, after shutting the engine off, there is a risk of reverse current that may damage a sensor or the ECU.

Black wire - Battery's negative

This wire is responsible for signal ground to the ECU so, it must be connected **straight to the battery's negative terminal**, with no seams. **Under no hypothesis, this wire can be connected to the vehicle chassis** or split with the ECU black/white wire (power ground). This will cause electromagnetic interference and other problems hard to diagnose and solve.

The black wire must have permanent contact with the battery's negative terminal, never being connected to switches, car alarms or others. To turn a FuelTech ECU off, the red wire should be switched on and off.

- Attach the negative wires to the battery terminal use ring terminals and avoid soldering them. A well crimped terminal has better resistance than a soldered one. Besides that, solder makes the joint stiffer, and less resistant to vibration, typically found in automotive applications.
- Use a crimping tool and insulate the wire with insulating tape or heat shrink tubing.
- If there's a need to solder the wire to the terminal, check it's resistance after the solder, it should be lower than 0.2 Ohms.

Obs.: If corrosion is found (green/White powder) on the battery terminals, clean it with a wire brush and baking soda or contact cleaner spray. Double check the terminal holder and replace it if necessary. Check resistance after the cleaning, it should be lower than 0.2 Ohms.

Green/Black wire - Negative for sensors

(TPS, air temp., pressure, rpm, distributor, etc.): It is vital to use sensors ground straight to the battery's negative terminal. Connecting them to chassis may cause electromagnetic interference, wrong readings or even damage to the sensors.

Black/White wire – power ground

These are the ECU power ground wires. They must be connected to the engine block or head in a place with a good electrical contact. The same shield that goes from the chassis to the battery's negative terminal is a good contact point.

The three power grounds (24 and 16-way connectors) must have permanent contact with the engine block/head, never being connected to switches, car alarms or others. To turn a FuelTech ECU off, the red wire should be switched on and off.

Power ground to ignition modules (SparkPRO, etc.), Peak and Hold drivers, relays and other accessories, must be connected to the same point, at the engine block/head.

A good test to check if the power grounds are with good connection is, using a tester, to measure the resistance between the battery's negative terminal and the chassis ground. Connect the red probe on the chassis point that the shield is connected and the black probe on the battery's negative. With the tester on the 200ohms range, the resistance measured must be below 0.2 Ohms.

Remember to touch both probes to check its resistance. This reading must be subtracted from the first reading to found the correct value.

OBS: it is very important to check the shield that connects the engine block to the chassis and to the battery. If this shield is defective, replace it by a new one, as it may cause serious damage to the ECU and its sensors. For this reason, we recommend the use of two of these shields.

Main switch installation (optional) – important tips

Main switches have been used for a long time in competition vehicles for safety purposes in case of an accident. Just like any other electric accessory, there's a correct way to install it:

The main switch cannot be connected to ground or power ground, under no circumstance!! This is the most common error by installers and, usually costs hours of work to fix all the problems that it cause. All of this without counting the huge possibility of damaging all the electronic accessories on the vehicle. **The main switch must ALWAYS control the battery's positive (12V).**

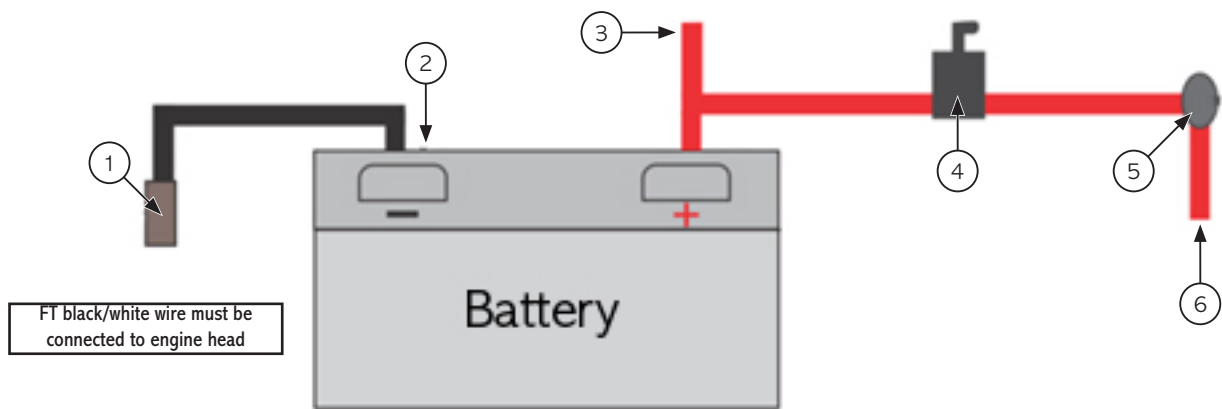

- 1 - Shield connecting battery negative to chassis and engine;
- 2 - FT black wire Battery negative;
- 3 - Positive wire to alternator;
- 4 - Main switch;
- 5 - Ignition Switch;
- 6 - Switched 12V;

9. FT600 connection on FT500 installation

FT600 can be installed on vehicles which already use FT500/FT500LITE, with no need to rewire everything. However, a few points must be checked or modified.

The best option is to make a new installation, using the FT600 harness, according to the recommendations here brought.

However, if to rewire is not possible, there is an other alternative: to cut the FT500 connectors and wiring them as shown below.

In order to do so a FT600 connector kit is needed (sold separately).

9.1 Ignition calibration

The ignition calibration screen on FT600 has the same parameters that previous FT ECUs, the difference is that they are in the same screen. After calibrating the ignition, the 1st tooth index position is automatically changed on the "Engine setup" menu.

When using distributor, the ignition must be calibrated on this screen, instead of turning the distributor.

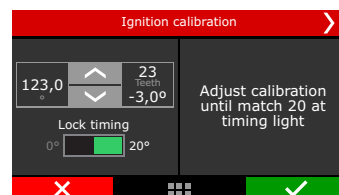
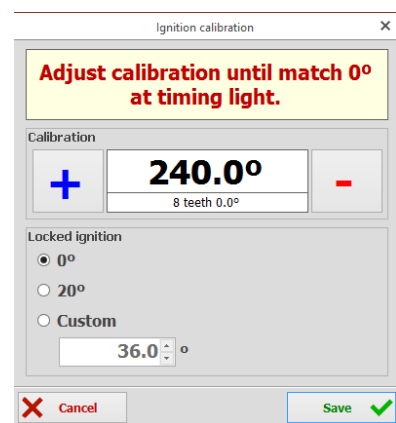

Ignition calibration screen: FTManager in FT600



NOTE:

In order to avoid any kind of damage to your installation, cut one wire at a time, crimp it and install it in the proper position.



WARNING:

*Check carefully and identify each connector:
A-Connector: 3 reference notches
B-Connector: 4 reference notches.*



IMPORTANT:

In the rear of both connectors the positions are sequentially numbered. The following diagrams show it considering a back view where the pins must be inserted.

A-Connector diagram - using FT500 wires

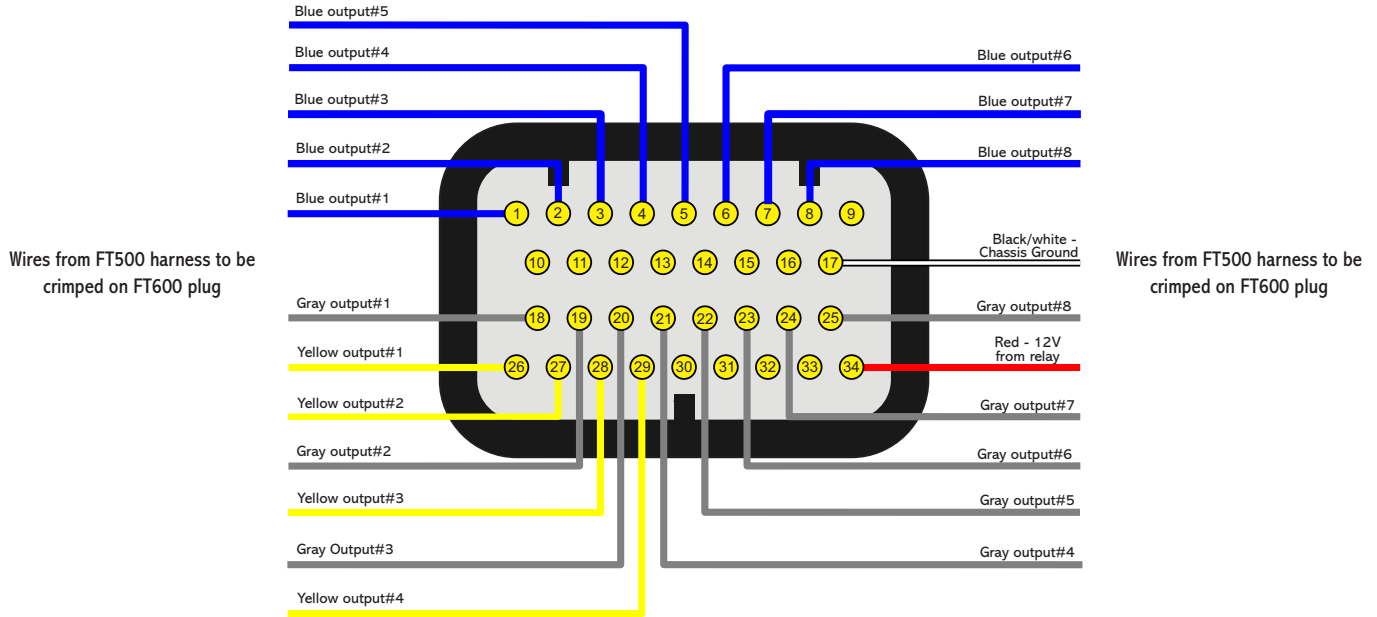

B-Connector diagram - using FT500 wires

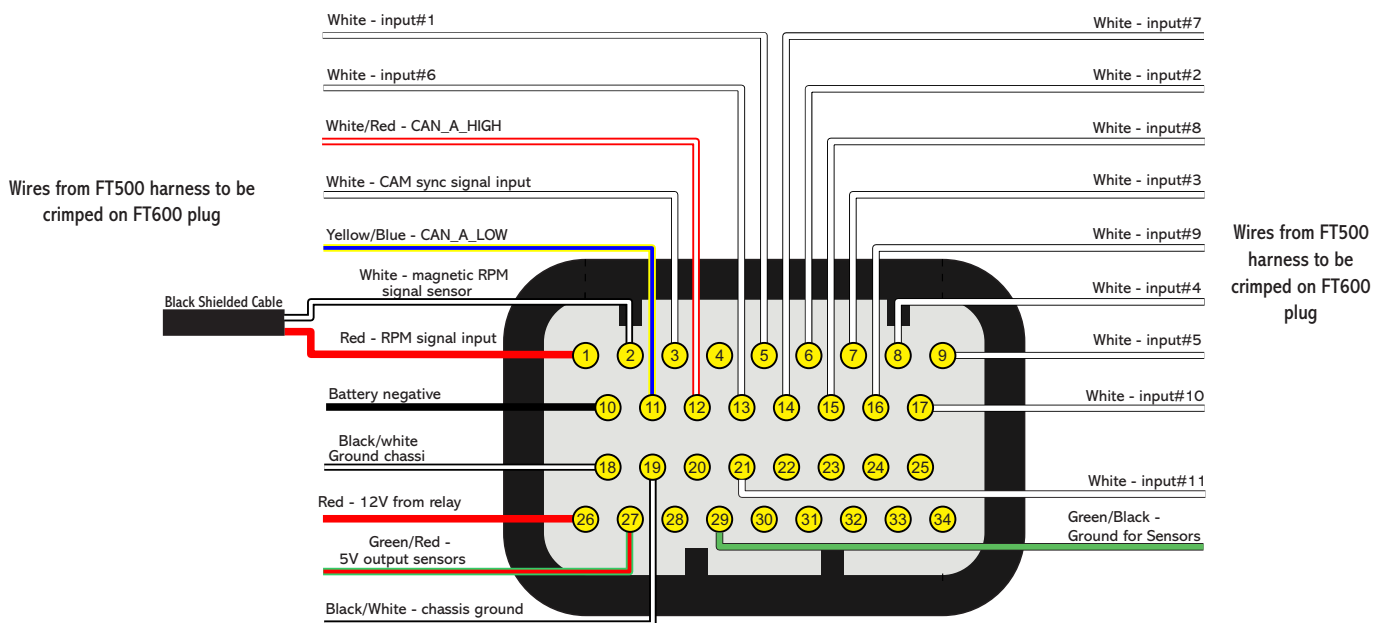

10. Fuel injectors

An FT600 has 8 outputs to control fuel injectors (blue wires #1 to #8). Each one of them can control up to 6 injectors with internal resistance above 10 Ohms (saturated injectors) or up to 4 injectors with internal resistance above 7 Ohms. Using a Peak and Hold driver, this capacity varies according to the output and the Peak and Hold current control (2A/0.5A, 4A/1A or 8A/2A).

In situations where more than 8 outputs are needed, the gray or yellow outputs can be set as injector outputs. In this case, the use of a Peak and Hold driver for these outputs is mandatory.

Injectors can be triggered in multipoint, semi sequential or sequential modes.

Examples of 4-cyl engines running high impedance injectors

- Individual triggering:** each blue output controls a cylinder. This is the most recommended connection cause is the only one that allows individual per cylinder fuel compensations, amongst other functions.

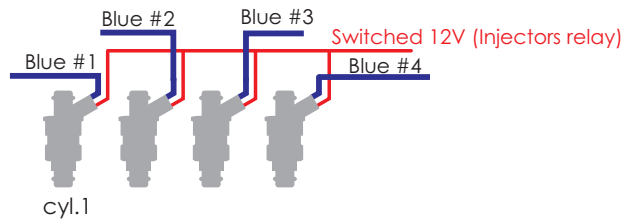

- Two injectors per channel:** blue output #1 controls injector of cylinders 1 and 4. Blue output #2 controls injectors of cylinders 2 and 3

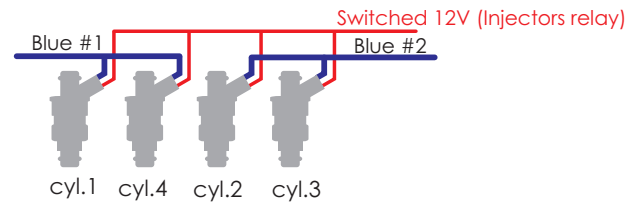

- Four injectors per channel:** use this connection only for compatibility with previous generation FT ECUs.

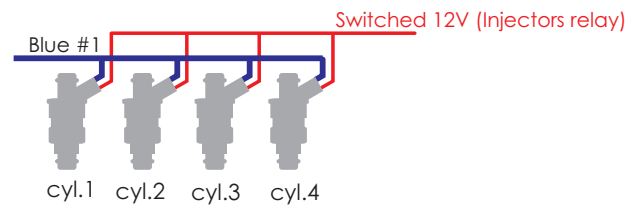

Even with each output controlling only one injector it is possible to change the triggering mode to multipoint (batch fire), semi sequential (outputs triggered in pairs) or sequential.

11. Ignition

An FT600 has 12 ignition outputs that can be used according to the needs of the project, controlling a distributor or a crank trigger.

Ignition with distributor

When using this ECU with a distributor, the only active ignition output is gray #1. This wire must trigger an ignition module or a coil with integrated igniter. When MSD configured it's utilized Yellow#1.

Coil with integrated igniter (smart coil)

They are coils with at least 3 pins and only one spark plug wire output. This kind of coil (inductive) must be set as "Falling dwell" in the "Ignition output" menu. In case of selecting the wrong output type, coil will be damaged.



- A - Ground (near coil) / igniter;
- B - Signal Ground;
- C - 5V signal from sequencer;
- D - Switched;

FuelTech SparkPRO-1 with coil without integrated igniter (dumb coil)

The FuelTech Spark PRO-1 module is an high energy inductive igniter which has an excellent cost/benefit and can be used with any 2-wire dumb coil (without internal igniter). Coils with primary least possible resistance are recommended for maximum SparkPRO-1 potential. The minimum resistance of the coil primary should be 0.3 ohms, below this the SparkPRO will be damaged.

Try to place SparkPRO-1 as close as possible to the coil.



Warning about the SparkPRO-1: An excessive charging time (Dwell) can damage the SparkPRO and the coil. It is recommended to use a Dwell map with 6ms at 8V, 4ms at 10V, 3.60ms at 12V and 3.00ms at 15V and check coils temperature at the beginning.



IMPORTANT:

In the "Ignition" menu, select the ignition output as "Falling dwell". In case of selecting the wrong output type, coil will be damaged.

Capacitive discharge ignition module (MSD 6A, MSD 7AL, Crane, Mallory)

FuelTech's ignition output must be connected to the MSD ignition module, (usually, the white wire is the points input). When using a MSD ignition box, the yellow #1 is automatically set up as ignition output.

The installation of ignition modules must always follow what is indicated by its manufacturer in the instructions manual. This ignition module will receive a Points signal from FuelTech. Ignition coil must follow the ignition module manufacturer recommendations as well.

Important Notes:

- The module must be placed the closest possible to the ignition coil, and never inside the car, in order to avoid the risk of interference on electronic devices.
- The length of the wires that connect the ignition module to the ignition coil must be the shortest possible.
- In "Ignition Setup," select the output "Rise (CDI)".
- It is not possible to control the ignition Dwell when using this type of module.
- To use the ignition cut through MSD, check Chapter 7.3

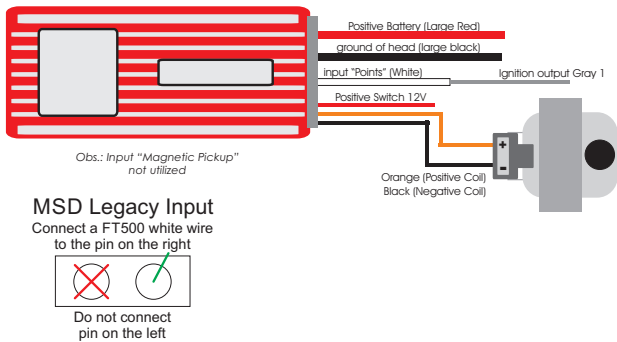

- When using MSD ignition modules with a distributor, it is necessary to connect a FuelTech white wire to the MSD Legacy input. That makes FT ECU to perform a faster timing control, especially needed when using Drag Race Features.

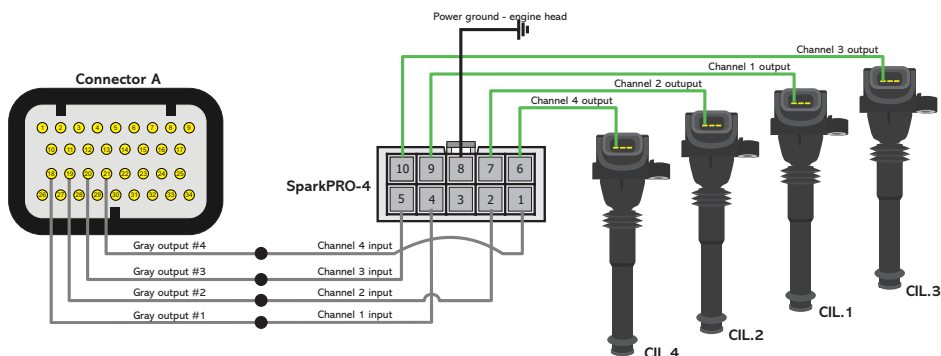

- When experiencing problems with the cut through MSD like no cut at all or RPM limit always 500 RPM above what was setup, use the other MSD pin.

Ignition with crank trigger

When controlling the ignition in distributor less systems, wasted spark or individual coils per cylinder are needed. In this case, coils are triggered by different outputs, according to the number of cylinders. Ignition outputs (gray wires) are triggered according to the firing order set up on the ECU

Example: 4 cylinder engine with individual coils:

Gray outputs are selected automatically, according to the number of cylinders.

Gray wires that will not be used for ignition control can be set up as injectors outputs (Peak and Hold driver is mandatory) or auxiliary outputs (relay needed).

Individual coils – electrical connections

On FT600 , these connections must be done by matching the output number with the cylinder number:

- Ignition output #1 controls cylinder #1 coil;
- Ignition output #2 controls cylinder #2 coil;
- Ignition output #3 controls cylinder #3 coil.

When working with dumb coils, an external ignition module must be used (as the FuelTech SparkPRO). In this case, ignition outputs from FT600 are connected to the ignition module inputs.

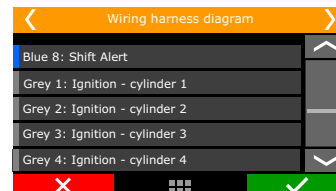

Wasted spark coils – electrical connections

In this case, ignition output #1 controls cylinder #1 and its twin, ignition output #2 controls cylinder #2 and its twin, etc.

When using dumb coils, an external igniter must be used, such as FuelTech SparkPRO. The FT600 ignition outputs (gray wires) will be connected to the igniter inputs and the igniter outputs will be connected to the coil.

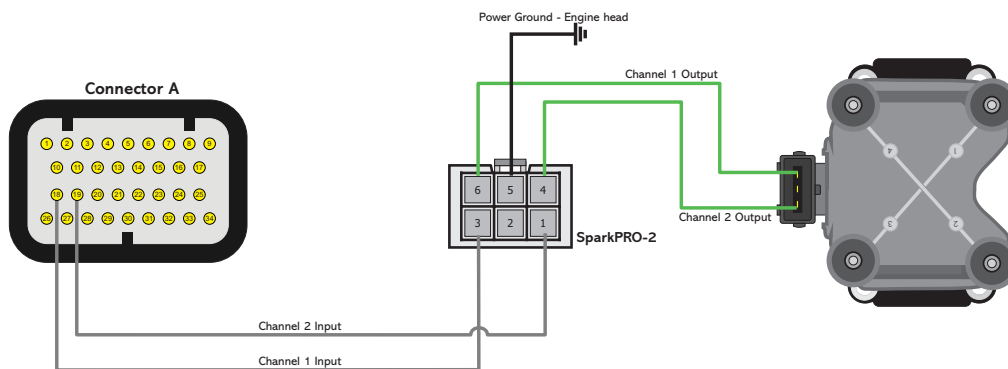

Resistor Installation gray outputs

When coils with integrated ignition module are used in your vehicle with FuelTech it's recommended to install a 100 ohms resistor (100R) in series with each gray output used in installation.

This procedure is used as a protection to the ECU against current discharges in adverse situations.

NOTE:
After installing the resistor, you must insulate the area with electrical tape or heat shrink.

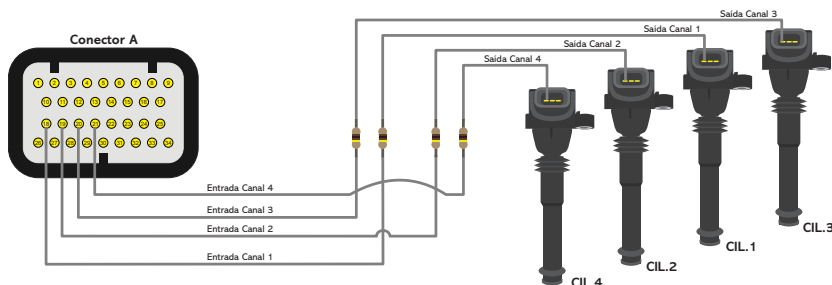

Individual coils connections

Coil	Type	Cars where it's usually found	Pins Connection
Renault 7700875000	No internal igniter Wire in serial association and use a SparkPRO-2	Renault engine 2.0 16V	Pin 1 bob 1: Ignition power (from SparkPRO or similar) Pin 2 coil 2: Switched 12V from relay Connect the pin 2 of coil 1 in the pin 1 of coil 2 (serial association) These coils work with 6V
Bosch 0221504024	No internal igniter	Fiat Punto/Linea 1.4 T-Jet	Pin 1: Power ground (engine head) Pin 2: Switched 12V from relay Pin 3: Ignition power (from SparkPRO or similar)
VW/Audi 20V/ BMW	No internal igniter	All VW/Audi 1.8 20V Turbo BMW 328	Pin 1: Ignition power (from SparkPRO or similar) Pin 2: Power ground (engine head) Pin 3: Switched 12V from relay
Magneti Marelli BAE700AK	No internal igniter (Dwell: 2,50ms)	Peugeot 306 and 405 2.0 16V Citroen Xantia and ZX 2.0 16V Maserati Coupé 3.2 32V	Pin 1: Switched 12V from relay Pin 2: Power ground (engine head) Pin 3: Ignition power (from SparkPRO or similar)
Toyota 90919-02205 129700-5150	No internal igniter	Toyota 2JZ, others Honda CBR 1000 (1,80ms)	Pin 1: Switched 12V from relay Pin 2: Ignition power (from SparkPRO or similar)
BOSCH 0221504470 0221504100	No internal igniter	BMW X1/X5/M5/118/120/320 E46/E39/E38/Z3/Z4/Z8	Pin 1: Connected to an ignition output (gray wire) Pin 2: Power ground (engine head) Pin 3: Switched 12V from relay

Coil	Type	Cars where it's usually found	Pins Connection
ACDelco 12611424	Integrated Igniter (Dwell: 4,5ms)	Corvette LS1	Pin A: Power ground (engine head) Pin B: Reference ground (ECU reference ground) Pin C: Connected to an ignition output (gray wire) Pin D: Switched 12V from relay
Diamond FK0140 (Dwell 3ms) Diamond FK0186 (Dwell 5ms)	Integrated igniter	Subaru WRX	Pin 1: Connected to an ignition output (gray wire) Pin 2: Power ground (engine head) Pin 3: Switched 12V from relay
Diamond FK0320	Integrated igniter	Pajero 3.8 6G75 MiVec	Pin 1: Switched 12V from relay Pin 2: Connected to an ignition output (gray wire) Pin 3: Power ground (engine head)
Hitachi CM11-202 Hanshin MCP3350 Hanshin MCP1330 Nissan 224891F00	Integrated igniter	Fiat Brava/Marea 1.8 Nissan Silvia S15 Nissan R34 (RB26DETT)	Pin 1 - +: Switched 12V from relay Pin 2 - B: Power ground (engine head) Pin 3 - IB: Connected to an ignition output (gray wire)
Hitachi AIC3103G	Integrated igniter	Mitsubishi Nissan 350 Z Infiniti G35/FX35	Pin 1: Connected to an ignition output (gray wire) Pin 2: Power ground (engine head) Pin 3: Switched 12V from relay
Audi/VW 06x 905 115 Hitachi CM11-201	Integrated igniter	Audi A6, S3 – VW Bora, Golf, Passat 1.8 Turbo	Pin 1: Switched 12V from relay Pin 2: Power ground (engine head) Pin 3: Connected to an ignition output (gray wire) Pin 4: Power ground (engine head)
Bosch 022 905 100x	Integrated igniter	VW VR6 – Golf, Passat	Pin 1: Reference ground (battery negative) Pin 2: Power ground (engine head) Pin 3: Switched 12V from relay Pin 4: Connected to an ignition output (gray wire)
Denso 099700-101 Denso 099700-115 Denso 099700-061 Hitachi CM11-109	Integrated igniter	Honda Fit	Pin 1: Connected to an ignition output (gray wire) Pin 2: Power ground (engine head) Pin 3: Switched 12V from relay
Denso 90919-022 ?? Final 27, 30, 36, 39 e 40	Integrated igniter	Toyota/Lexus V6 3.0	Pin 1: Power ground (engine head) Pin 2: Connected to an ignition output (gray wire) Pin 3: Do not connect Pin 4: Switched 12V from relay
VW 030905110D	Integrated igniter	VW Gol/Voyage G6	Pin 1: Reference ground (battery negative) Pin 2: Connected to an ignition output (gray wire) Pin 3: Power ground (engine head) Pin 4: Switched 12V from relay
Denso 10R 035444	Integrated igniter	Toyota Camry 2.4	Pin 1: Switched 12V from relay Pin 2: Reference ground (battery negative) Pin 3: Connected to an ignition output (gray wire) Pin 4: Power ground (engine head)
Bosch 0221604104	Integrated igniter	Captiva / Omega V6 3.6	Pin A: Power ground (engine head) Pin B: Reference ground (battery negative) Pin C: Connected to an ignition output (gray wire) Pin D: Switched 12V from relay
Bosch 0221604014	Integrated igniter	Nissan Sentra	Pin 1: Connected to an ignition output (gray wire) Pin 2: Ground Pin 3: Switched 12V from relay
MSD PN 82558	No internal igniter	MSD PN 82558	Pin 1: Ignition power (from SparkPRO or similar) Pin 2: Do not connect Pin 3: Switched 12V from relay
Bosch 0221504014 0221504460	No internal igniter	Fiat Marea 2.0T, 2.4 (3,60ms) Fiat Stilo Abarth 2.4 20V (1,80ms)	Pin 1: Ignition power (from SparkPRO or similar) Pin 2: Power ground (engine head) Pin 3: Switched 12V from relay
30520-R1A-A01	Integrated igniter	New Civic	Pin 1: Switched 12V from relay Pin 2: Reference ground (battery negative) Pin 3: Ignition power (from SparkPRO or similar)

Wasted spark coils connections

Coil	Type	Cars where it's usually found	Pin Connection
Bosch F000Z S0103	No integrated igniter (two spark plug outputs)	Fiat Palio, Siena, Uno 1.0 , 1.5, 1 .6, Tempra 2 .0	Pin 1: Ignition power (from SparkPRO or similar) Pin 2: Switched 12V from relay
Bosch 4 cylinders (3 wires) F 000 Z S0 213 F 000 Z S0 222 O 221 503 011	No integrated igniter	Celta, Corsa, Gol Flex, Meriva, Montana Vectra 16V Fiat Linea 1.9 16V	Pin 1a (A): Ignition power (from SparkPRO or similar) Pin 15 (B): Switched 12V from relay Pin 1b (C): Ignition power (from SparkPRO or similar)
Bosch 4 cylinders (3 wires) F 000 ZS0 203 F 000 ZS0 205	No integrated igniter	Astra, Kadett, Ipanema, Vectra 8V, Zafira	Pin 1: Ignition power (from SparkPRO or similar) Pin 2: Switched 12V from relay Pin 3: Ignition power (from SparkPRO or similar)
47905104 19005212 1208307 (6 wires – 4 channels)	No integrated igniter Individual cylinder triggering	Fiat Stilo 1.8 16V GM Meriva 1.8 16V GM Zafira 1.8 and 2.0 16V	Pin A – cyl. 3: Ignition power (from SparkPRO or similar) Pin B – cyl. 2: Ignition power (from SparkPRO or similar) Pin C – cyl. 1: Ignition power (from SparkPRO or similar) Pin D – cyl. 4: Ignition power (from SparkPRO or similar) Pin E: Power ground (engine head) Pin F: Switched 12V from relay
Bosch 6 cylinders O 221 503 008	No integrated igniter	GM Omega 4.1, Ford V6	Pin 1: Ignition power (from SparkPRO or similar) Pin 2: Ignition power (from SparkPRO or similar) Pin 3: Ignition power (from SparkPRO or similar) Pin 4: Switched 12V from relay
Delphi 4 cylinders (round)	Integrated igniter	GM Corsa MPFI (of 98 to 2002)	Pin A: Gray #2 (cylinders 2 and 3) Pin B: Gray #1 (cylinders 1 and 4) Pin C: Power ground (engine head) Pin D: Switched 12V from relay
Bosch F000Z S0103	No integrated igniter (two spark plug outputs)	Fiat Palio, Siena, Uno 1.0 , 1.5, 1 .6, Tempra 2 .0	Pin 1: Ignition power (from SparkPRO or similar) Pin 2: Switched 12V from relay
Bosch 4 cylinders (3 wires) F 000 Z S0 213 F 000 Z S0 222 O 221 503 011	No integrated igniter	Celta, Corsa, Gol Flex, Meriva, Montana Vectra 16V Fiat Linea 1.9 16V	Pin 1a (A): Ignition power (from SparkPRO or similar) Pin 15 (B): Switched 12V from relay Pin 1b (C): Ignition power (from SparkPRO or similar)
Bosch 4 cylinders (3 wires) F 000 ZS0 203 F 000 ZS0 205	No integrated igniter	Astra, Kadett, Ipanema, Vectra 8V, Zafira	Pin 1: Ignition power (from SparkPRO or similar) Pin 2: Switched 12V from relay Pin 3: Ignition power (from SparkPRO or similar)
47905104 19005212 1208307 (6 wires – 4 channels)	No integrated igniter Individual cylinder triggering	Fiat Stilo 1.8 16V GM Meriva 1.8 16V GM Zafira 1.8 and 2.0 16V	Pin A – cyl. 3: Ignition power (from SparkPRO or similar) Pin B – cyl. 2: Ignition power (from SparkPRO or similar) Pin C – cyl. 1: Ignition power (from SparkPRO or similar) Pin D – cyl. 4: Ignition power (from SparkPRO or similar) Pin E: Power ground (engine head) Pin F: Switched 12V from relay
Bosch 6 cylinders O 221 503 008	No integrated igniter	GM Omega 4.1, Ford V6	Pin 1: Ignition power (from SparkPRO or similar) Pin 2: Ignition power (from SparkPRO or similar) Pin 3: Ignition power (from SparkPRO or similar) Pin 4: Switched 12V from relay

Coil	Type	Cars where it's usually found	Pin Connection
Delphi 4 cylinders (round)	Integrated igniter	GM Corsa MPFI (of 98 to 2002)	Pin A: Gray #2 (cylinders 2 and 3) Pin B: Gray #1 (cylinders 1 and 4) Pin C: Power ground (engine head) Pin D: Switched 12V from relay
Delphi 4 cylinders (square)	Integrated igniter	GM Corsa MPFI (of 98 to 2002)	Pin 1: Switched 12V from relay Pin 2: Power ground (engine head) Pin 3: Gray #1 (cylinders 1 and 4) Pin 4: Gray #2 (cylinders 2 and 3)
Sagem 96358648	No integrated igniter	Peugeot 1.4	Pin 1: Gray #1 (cylinders 1 and 4) Pin 2: Gray #2 (cylinders 2 and 3) Pin 3: Power ground (engine head) Pin 4: Switched 12V from relay
Bosch 4 Cylinders (4 wires) 032 905 106 B/D F000ZS0210	Integrated igniter	VW Golf, Bora, Audi A3 and A4, Seat Ibiza and Córdoba	Pin 1: Gray #1 (cylinders 1 and 4) Pin 2: Switched 12V from relay Pin 3: Gray #2 (cylinders 2 and 3) Pin 4: Power ground (engine head)
Eldor – 4 Cylinders (6 wires – 4 channels) 06A 905 097 06A 905 104	Integrated igniter Individual cylinder triggering	Bora, New Beetle, Polo	Pin 1: Power ground (engine head) Pin 2: Gray - C (cylinder 4) Pin 3: Gray - B (cylinder 3) Pin 4: Gray - D (cylinder 2) Pin 5: Gray - A (cylinder 1) Pin 6: Switched 12V from relay
VW V6 078 905 104	Integrated igniter	Audi A4 2.8 V6 Audi A6 Passat 2.8 V6	Pin 1: Power ground (engine head) Pin 2: Gray #1 (cylinders 1 and 4) Pin 3: Gray #2 (cylinders 2 and 5) Pin 4: Gray #3 (cylinders 3 and 6) Pin 5: Switched 12V from relay
GM Coil 94702536 DELPHI CE20131	Integrated igniter	GM Agile 1.4	Pin A: Gray #2 (cylinders 2 and 3) Pin B: Gray #1 (cylinders 1 and 4) Pin C: Reference ground (battery negative) Pin D: Power ground (engine head) Pin E: Switched 12V from relay
Pantera coil	Integrated igniter	-	Pin A: Gray #1 Pin B: Reference ground (battery negative) Pin C: Power ground (engine block) Pin D: Power ground (engine head) Pin E: Switched 12V from relay
BMW	No integrated igniter	318ti compact 94/00	Pin 1: cylinder 4 - Sparkpro Pin 2: Switched 12V from relay Pin 3: Power ground (engine block) Pin 4: Not used Pin 5: Cylinder 1 - Sparkpro Pin 6: Cylinder 3 - Sparkpro Pin 7: Cylinder 2 - Sparkpro

12. Sensors and actuators

FT600 has some pre-defined sensors available as standard, but, it's possible to setup any kind of analog sensor on its inputs or even to connect it and read a sensor in parallel with the OEM ECU. This configuration is done on the custom mode through software FTManager and USB cable on a PC.

12.1 Intake air temperature sensor

With this sensor, the ECU can monitor the intake air temperature and perform real time compensations.

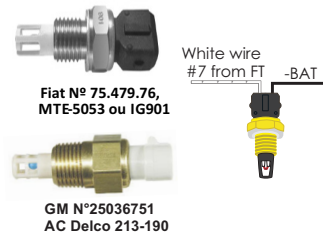

Models:

- Fiat: Delphi / NTK (3,3kΩ a 20°C);
- GM (American): ACDelco: 213-190 / GM n°25036751.

One of its pins is connected to the battery negative. The other to the white #7 wire (standard – can be changed).

12.2 Engine temperature sensor

This sensor is very important for a good running engine, as varying engine temperatures dramatically affect an engine's fuel and timing requirements.

On water cooled engines, place this sensor near the engine head, reading the water temperature. On air cooled engines, install this sensor reading the engine oil temperature.

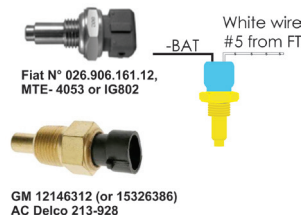

Models:

- Fiat: Delphi / NTK (3,3kΩ a 20°C);
- GM (American): ACDelco: 213-928 / GM: 12146312 (or 15326386).

One of its pins is connected to the battery negative. The other to the white #5 wire (standard – can be changed).

12.3 Fuel and oil pressure

FuelTech PS-150/300/1500 is a high precision sensor responsible for general pressure readings (fuel, oil, boost, exhaust back pressure, etc.) It can be purchased online at www.fueltech.net or from an authorized FuelTech dealer (check the website to locate the dealer nearest to you).

FuelTech PS-150/300/1500 sensor below:

- Connection: 1/8" - 27NPT
- Pressure Range: 0 to 150/300/1500psi
- Power Voltage: 5V
- Output Scale: 0.5-4.5V
- Electric Connector: 3-way Metri Pack 150

Pin A: Battery's Negative

Pin B: 5V supply

Pin C: Output signal

FuelTech part numbers:

5005100020 - 0-150 psi sensor

5005100021 - 0-300 psi sensor

5005100022 - 0-1500 psi sensor



As FT600 is fully configurable, practically any automotive pressure sensor can be used – if the voltage x pressure table is known, you can setup through FTManager software.

12.4 Throttle position sensor (TPS)

This sensor is a potentiometer installed on the throttle to inform the ECU about its position. If needed, it is possible to run the engine without this sensor, but, it is very important for a fine tuning. When possible, use the OEM TPS. This ECU is calibrate to any kind 0-5V TPS sensor. Anyway, FuelTech products are compatible with any 0-5V TPS sensor, since they have calibration function.

Discovering the TPS pinout

With a multimeter in the range of 20k Ohms, disconnect the from the FuelTech ECU and let the ignition key off. Check the resistance between the Green/Red (5V supply) and Black (battery's negative) wires. Resistance should not vary when accelerating. If vary, reverse the wires so that the resistance of the TPS varies only between the White wire #11 (default TPS input signal) and Green/Red and between White #11 and Black wires.

The TPS signal voltage should vary according to throttle opening, with gap bigger then 3V between fully closed and wide open throttle.

12.5 Crank trigger/RPM sensor

To control fuel and ignition, this ECU is able to read magnetic and Hall Effect sensors.

Distributor

To read RPM signal from a Hall Effect distributor, it should have a sensor with at least 3 pin and have the same number of reading windows (or "triggers") than the engine has number of cylinders.

VW Hall Effect distributor connections

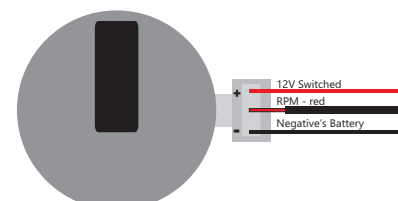

Crank trigger

The crankshaft trigger wheel is responsible for informing the exact position of the crankshaft to the electronic ignition management system, in such a way that this system is able to determine the ignition timing in the engine. The trigger wheel is installed on the crankshaft, outside or inside the engine block, with a specific alignment. Usually, the Crankshaft Trigger Wheels placed on the outside of the block are put in front of the engine, by the front crankshaft pulley, or in the rear of the engine, by the flywheel. There are many types of Trigger Wheels, but the compatible ones are mentioned below

60-2: this is, in general, the most used type of trigger wheel. It is a wheel with 58 teeth and a gap (fault point) equivalent to two missing teeth, therefore called "60-2". This trigger wheel is found in most Chevrolet (Corsa, Vectra, Omega, etc.), VW (Golf, AP TotalFlex, etc.), Fiat (Marea, Uno, Palio, etc.), Audi (A3, A4, etc.) and Renault (Clio, Scènic, etc.) Models, among other car makers. Ford Flex models with Marelli ECU use this type of trigger wheel also.

36-2: standard in Toyota engines, being 34 teeth and a gap equivalent to two missing teeth.

36-1: 35 teeth and a gap equivalent to one missing tooth. It can be found in all Ford vehicle lines, with 4 or 6 cylinders (except the Flex models with Marelli injection, which use the 60-2 trigger wheel).

12 teeth: this type is used by AEM's Engine Position Module (EPM) distributor. In this case, the cam sensor from the EPM must be used. This distributor has 24 teeth, but as it rotates half-way for each full engine RPM, there will only be 12 teeth per RPM. Setup the Ignition with 12 teeth at crank (24 at cam) and the 1st tooth alignment with 60°.



AEM EPM Module

- Red: Switched 12V;
- Black: Battery negative;
- Yellow: red wire from the black shielded cable, white wire must be left disconnected. Setup it as Hall Effect RPM sensor, falling edge;
- White: white wire from the gray shielded cable. Setup it as Hall Effect CAM sensor – falling edge.

Setup ECU as 12 teeth (at crank) 24 (at cam) and use 60° for 1st tooth alignment.

Mitsubishi 1G CAS: due to the fact the CAM signal has two slots on this CAS, it's only possible to control the ignition on wasted spark mode and the fuel injection on multipoint or semi-sequential. No sequential fuel or ignition will work on this CAS with 2 slots on the CAM.

- **Pin 1** – white – CAM signal: connect to white wire from FT600 gray shielded cable (pin 15)

- **Pin 2** – yellow – CRANK signal: connect to red wire from FT600 black shielded cable (pin 17)
- **Pin 3** – red – sensor feed: connect to a switched +12V
- **Pin 4** – black – sensor ground: connect directly to battery's negative.

FT600 setup: RPM signal "2 (crank) or 4 (cam)" (4G63) or "3 (crank) or 6 (cam)" (6G72), Hall Effect crank and cam sensors, rising edge on both. Wasted spark ignition. 1st tooth alignment: 67

Mitsubishi 2G CAS: uses the same settings that 1G CAS, but has a sensor on the crankshaft (reading a 2 tooth trigger) and a cam sync sensor.

Crank trigger sensor:

- Pin 1: switched 12V
- Pin 2: CRANK signal: connect to red wire from FT600 Black shielded cable (pin 17)
- Pin 3: connect directly to battery's negative

Cam sync sensor:

- Pin 1: switched 12V
- Pin 2: CAM signal: connect to white wire from FT600 gray shielded cable (pin 15)
- Pin 3: connect directly to battery's negative

Ignition settings:

- **Stock Honda coil and igniter:** setup ignition as "Distributor – single coil" and select option "Rising edge (Honda distributor)". In this option, only the ignition output #1 will be active.
- **Multi coils and/or external igniter:** in this case, ignition can be controlled in wasted spark or sequential modes. Ignition output must be setup as "Honda distributor", but as Falling edge or Rising edge, according to the external igniter used.
- **1, 2, 3, 4, 5, 8, 10 and 24 teeth:** options available according to the number of engine cylinders. When having these trigger wheels, the use of a camshaft position sensor is mandatory, in order to maintain the synchronization of the parts. Also, the teeth must be equidistant. They can be found in models such as Subaru, Mitsubishi Lancer and 3000GT, GM S10 Vortec V6, etc.

Honda Distributor

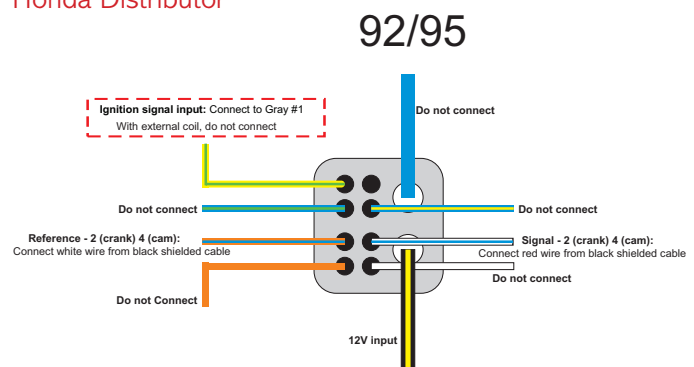

96/00

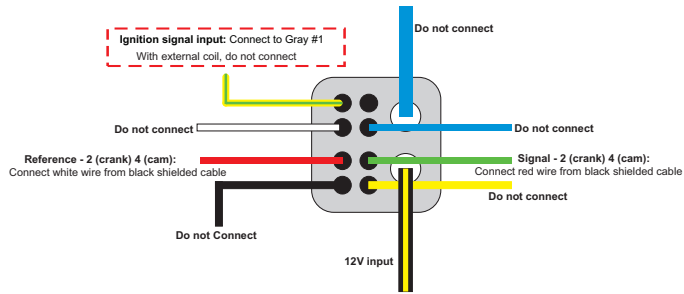

Distributor Pin	Honda 92/95 (wire color)	Honda 96/00 (wire color)	FT600 connection	Configuration
1	Yellow/green	Yellow/green	With OEM coil and igniter, connect gray #1 wire	With stock Honda coil and igniter: connect to gray wire #1 and setup as " Honda Distributor ". With multi-coils, and external igniter: do not connect
2	Blue/Green	White	Do not connect	
3	Orange/Blue	Red	Connect white wire from black shielded cable	Reference - 2 (crank) 4 (cam)
4	Orange	Black	Do not connect	
5	Blue/Yellow	Blue	Do not connect	
6	White/Blue	Green	Connect red wire from black shielded cable	Signal - 2 (crank) 4 (cam)
7	White	Yellow	Do not connect	
8	Blue	Blue	Do not connect	
9	Black/Yellow	Black/Yellow	12V input	12V input for OEM coil and igniter (inside the distributor) With external coil, do not connect

MSD distributor and crank trigger:

The distributors are equipped with VR/magnetic sensors e must be wired as the following:

- Orange/black: connected to the red wire of black shielded cable of FT600
- Purple/black: connected to the white wire of black shielded cable of FT600

Any mechanical or centrifugal advance must be locked. The crank trigger kits have different wire colors and the wiring must be as following:

- Purple: connected to the red wire of black shielded cable of FT600;
- Green: connected to the white wire of black shielded cable of FT600

The RPM signal settings must be:

- 4 cylinders: 2 (at crank) or 4 (at cam);
- 6 cylinders: 3 (at crank) or 6 (at cam);
- 8 cylinders: 4 (at crank) or 8 (at cam);

RPM sensor:

VR differential, rising edge, crank index position 45° (need to calibrate ignition with timing light)

Cam sync sensor:

Not utilized, unless you are running crank trigger and distributor (or a dedicated cam sync sensor) with a single tooth.

48-2, 30-2, 30-1, 24-2, 24-1, 15-2, 12-3, 12-2, 12-1, 12+1 and 4+1 teeth: These are less common types, but they are perfectly compatible. These trigger wheels can operate without a camshaft position sensor, as they have a gap that indicates the TDC on cylinder 1.

In order to correctly inform the engine position to the injection module, it is necessary that the injection has the right information about the alignment of the trigger wheel in relation to the TDC on cylinder 1. The image below shows a 60-2 trigger wheel with the sensor aligned on the 15th tooth after gap. In this image, for example, the engine is on the TDC on cylinder 1. Notice that the RPM is clockwise, and therefore, the TDC on cylinder 1 is set 15 teeth after the sensor passes the gap. That is exactly the number of teeth that must be informed to the injection upon its configuration.

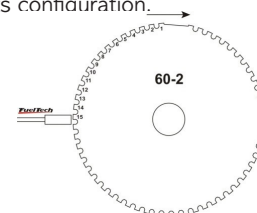

60-2 Trigger Wheel Aligned on the 15th tooth after the gap

Of the space in between them. The minimum diameter for the fabrication of a 60-2 trigger wheel is 125mm (5”).

generates an electromagnetic signal based on induction. It might have 2 or 3 wires (the third wire is an electromagnetic shield).

For 36-1 trigger wheels, the minimum diameter recommended is 100mm (4”). Trigger wheels with smaller diameters can be fabricated, but reading errors may occur and the engine may not work.

Hall Effect sensor: it is usually found on 2, 3 and 4-tooth trigger wheels and some 36-1 and 60-2 types. It receives a 5V or 12V feed and emits a square wave signal. It invariably has 3 pins: voltage, negative and signal.

Crankshaft trigger sensor

When controlling the ignition with a trigger wheel, it is necessary to have a sensor that reads the signal from its teeth and informs the engine position to the injection. There are two types of crankshaft trigger sensors:

VR sensor: this is the type that is most commonly used in cars nowadays, especially with 60-2 and 36-1 trigger wheels. One of its main characteristics is that it does not receive 12V or 5V; it only

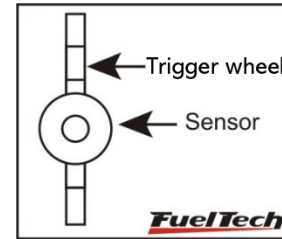

The crank Wheel should be aligned with the sensor

Crank trigger sensors table

Sensor	Type	Cars where it's usually found	Pin connection
Bosch 3 wires	VR	Chevrolet Corsa 8V MPFI, Omega 2.2, 4.1 and 2.0 (alcohol), S10 2.2, Silverado, Astra, Kadett MPFI, Vectra, Calibra, VW Golf, Passat, Alfa 164 3.0	Pin 1: red wire (black shielded cable) Pin 2: white wire (black shielded cable) Pin 3: shield (black shielded cable)'
Bosch 3 wires	VR	Chevrolet Omega 2.0 Gasolina and 3.0, Corsa 16V/ GSi, Tigra, Fiat Marea 5 Cilindros, Citroën ZX 2.0, Xantia 2.0, Peugeot 306 2.0 16V, Peugeot 405MI Fiat Linea 1.9 16V	Pin 1: white wire (black shielded cable) Pin 2: red wire (black shielded cable) Pin 3: shield (black shielded cable)
Ford 2 wires Fiat 2 wires	VR	Ford Zetec, Ranger V6 Fiat Punto/Fiat 500 1.4 Turbo	Pin 1: red wire (black shielded cable) Pin 2: white wire (black shielded cable)
Siemens 2 wires	VR	Renault Clio, Scenic	Pin A: red wire (black shielded cable) Pin B: white wire (black shielded cable)
Magneti Marelli (P/N Fiat 464.457.31) (P/N Marelli 4820171010)	VR	Fiat Palio, Uno, Strada, Siena 1.0 – 1.5 8V MPI	Pin +: red wire (black shielded cable) Pin -: white wire (black shielded cable) Pin S: shield (black shielded cable)
Delphi 3 wires (3 teeth wheel)	Hall	GM S10 4.3 V6	Pin A: 5V (FT green/red wire) Pin B: battery negative Pin C: red wire (black shielded cable)
Fiat engine E-TorQ 1.8 16V	Hall	Fiat engine E-TorQ 1.8 16V	Pin 1: battery negative Pin 2: red wire (black shielded cable) Pin 3: 5V (FT green/red wire)
VW TotalFlex/Gol Gti Hyundai Tucson 2.0 16V	Hall	all VW AP TotalFlex Hyundai Tucson 2.0 16V	Pin 1: 5V (FT green/red wire) Pin 2: red wire (black shielded cable) Pin 3: battery negative
Denso (Suzuki Bikes)	VR	Suzuki Hayabusa e Suzuki SRAD	Pin 1: red wire (black shielded cable) Pin 2: white wire (black shielded cable)
Mitsubishi 1.6 16V (2 teeth)	Hall	Mitsubishi Colt e Lancer	Pin 1 - black: battery negative Pin 2 - brown: red wire (black shielded cable) Pin 3 - red: 5V (FT green/red wire)
VW/Audi 20V3 wires Bosch – 0261210148	VR	Audi A3 1.8 20V VW Golf 1.8 20V/Golf 1.6, 2.0/Bora 2.0– EA111	Pin 1: shield (black shielded cable) Pin 2: white wire (black shielded cable) Pin 3: red wire (black shielded cable)
Denso 3 wires	Hall	Honda Civic Si	Pin 1: 5V (FT green/red wire) Pin 2: shield (black shielded cable) Pin 3: red wire (black shielded cable)

**NOTE:**

If a VR sensor doesn't pick up RPM signal, try to swap the sensor wires (red and white wires)

A very simple test using a tester can identify if a Crankshaft Trigger Sensor is an inductive or a Hall Effect sensor. Turn the tester on the resistance measurement mode at a 2000Ω scale and connect its probes to the sensor's pins. Test pin 1 with the other two. If a resistance of 600-1200Ω is found, the sensor tested is of inductive type.

If no resistance is found among any of the pins, or if the resistance found is much higher than 1200Ω, it is either a Hall Effect sensor, or an inductive sensor with a broken coil. Notice that, when finding

the resistance between pins 2 and 3, for example, pin 1 must be connected to the battery's negative terminal and the other 2 to FT shielded cable. If the module does not capture the signal, invert the white and red wires connections.

12.6 Camshaft position sensor

This sensor tells the ECU when the cylinder #1 is reaching its TDC on the compression stroke. With this information it is possible to control ignition and fuel injection in sequential mode.

Installation and alignment of this sensor are pretty simple. The only requirement is that this sensor is triggered before the crank trigger sensor goes through the gap on the crank trigger wheel.

Cam sync sensors table

Sensor	Type	Cars where it's usually found	Pin connection
Bosch 3 wires	Hall	Chevrolet Astra 16V, Calibra, Vectra, Ômega 4.1, Zafira 6V, Citroën ZX 2.0, Xantia, Peugeot 306 2.0 16V, 05MI, Hyundai Tucson 2.0 6V, Fiat Marea 5 Cylinders all VW/Audi 1.8 20V	Pin 1: 5V (FT green/red wire) Pin 2: white wire (gray shielded cable) Pin 3: shield (gray shielded cable)
Bosch 3 wires	Hall	Chevrolet Vectra 16V (97 and on) Fiat Punto T-Jet, Fiat 500 Fiat E-TorQ1.8 16V e 1.4 Turbo	Pin 1: shield (gray shielded cable) Pin 2: white wire (gray shielded cable) Pin 3: 5V (FT green/red wire)
Bosch 3 wires	Hall	Chevrolet Corsa 16V, Tigra	Pin 15: 5V (FT green/red wire) Pin 6: white wire (gray shielded cable) Pin 17: shield (gray shielded cable)
Delphi Cam sensor	Hall	GM S10 4.3 V6	Pin A: shield (gray shielded cable) Pin B: white wire (gray shielded cable) Pin C: 5V (FT green/red wire)
Bosch 3 wires	VR	Alfa 164 6 cylinders	Pin 1: shield (gray shielded cable) Pin 2: white wire (gray shielded cable) Pin 3: shield (gray shielded cable)
Ford 2 wires Denso (Suzuki Bikes)	VR	Ford Zetec, Ranger V6 Suzuki Hayabusa e Suzuki SRAD	Pin 1: white wire (gray shielded cable) Pin 2: shield (gray shielded cable)
3 wires (close the small hole with an adhesive)	Optical	Mitsubishi 1.6 16V	Pin 1 - black: shield (gray shielded cable) Pin 2 - white/red: white wire (gray shielded cable) Pin 3 - red: 5V (FT green/red wire)
Denso 3 wires	Hall	Honda Civic Si	Pin 1: 5V (FT green/red wire) Pin 2: shield (gray shielded cable) Pin 3: white wire (gray shielded cable)

12.7 O2 sensor

Wideband O2 sensor

The use of wideband lambda sensors on FT600's input requires an external conditioner (WB-O2 Slim or WB-O2 Datalogger). It is important to verify the measurement range of conditioner analog output, as this will be informed during the configuration of FT600's O2 input (0,65-1,30, 0,65-4,00 or 0,65 to 9,99)

Narrowband O2 sensors

Although less precise than the wideband lambda sensor, narrowband O2 sensors can be connected to the ECU input for the display of values (in Volts) at the Dashboard and at the Diagnostic Panel. Narrowband O2 sensors usually follow a standard set of colors, facilitating the wiring. The table below shows the wiring instructions based on the color scheme generally used for O2 sensor wires:

wire Color	4-wire O2 sensor	3-wire O2 sensor	1-wire
Black	Signal Output	Signal Output	Signal
White (2 wires)	Switched 12V and ground (connect one wire onto the 12V and the other to ground – there is no polarity)		Not featured
Gray	Battery's negative terminal	Not featured	Not featured

As a general rule, if there are two wires with the same color, one is the switched 12V and the other is the ground. After connecting the O2 sensor to the ECU, the O2 sensor input must be set up as guides chapter 15.5.

12.8 Step motor – idle speed

Its control is done through the four yellow outputs of the connector A, also used for electronic throttle control. After selecting the idle speed control as step motor the four yellow outputs are automatically set up as “step motor” on the harness connection table. Below are some known step motor connections.

VW stepper motor - Magneti Marelli

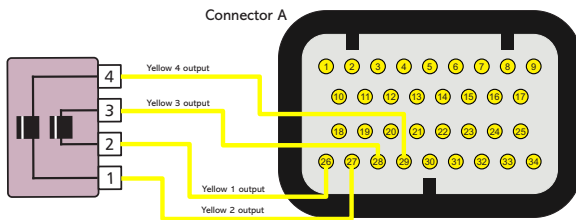

Engines VW: Magneti Marelli
N°: 40430102 / 40439102

Pin 1: Yellow 2
Pin 2: Yellow 1
Pin 3: Yellow 3
Pin 4: Yellow 4



IMPORTANT NOTE:

Step motor is calibrated every time the ECU is turned on, so, before cranking the engine, it is recommended to wait about 2s after turning the ignition switch on. If this procedure is not respected, the engine may be revved up unwittingly during the step motor calibration, coming back to normal within seconds.

If your step motor is different from the ones listed here, do what follows:

1. Put a tester on the 200 Ohms range;
2. Measure the step motor actuators until you find a resistance of approximately 50 Ohms. That's one pair of coils;
3. Connect yellow #1 and yellow #3 to a pair of coils and yellow #2 and yellow #4 to the other pair;
4. If the step motor remains fully opened after the calibration, change yellow #1 by yellow #3 position.

GM stepper motor - Delphi

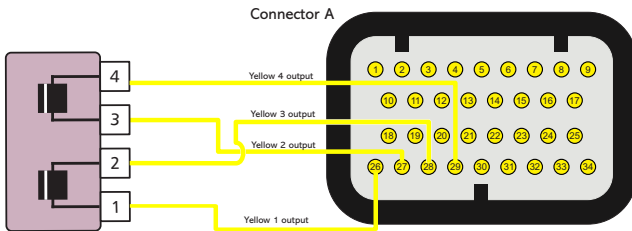

GM Engines: Chevrolet / Delphi
N°: 17108187 / ICD00124

Pin 1: Yellow 1
Pin 2: Yellow 3
Pin 3: Yellow 2
Pin 4: Yellow 4



FT600 step motor control is compatible with the great majority of actuators nowadays.

Usually, with this simple test you're able to make the step motor work normally.

13. Auxiliary outputs

The installation of a fuse equivalent to the charge is recommended. The auxiliary outputs have an overload protection system, with automatic current cut-off. They trigger the charges (lamps, relays, etc.) with a negative signal. Thus, the positive terminal must be connected to a switched 12V.

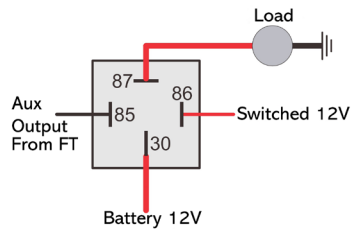

The auxiliary outputs must be set manually according to the desired function in the outputs (blue, gray or yellow wires) that are not being used as injector or ignition outputs.

In case of having back current and keeping relays switched on with ECU powered off, use a 1N4004 diode.

Each output must be configured in accordance to its function.

For more information about the outputs programming, see chapter 19.

13.1 Cooling fan 1 e 2

This output is responsible for switching an electric fan according to the module's settings. The relay used must be adequate to the electric fan's current (50A, for example). The relay is switched by negative (sourced by the output), and the positive a switched 12V.

Important Note: the electric fan must not be connected directly to the auxiliary output without the use of a relay; otherwise, the output will be damaged.

13.2 Idle valve

This function opens a valve which increases the air flow in the intake, helping the engine to idle.

We recommend normally closed valves, such as boost or purge (EVAP) solenoids.

An appropriate relay must be used according to current and voltage. The FT600 output switches ground and the 12V must be a switched 12V.

13.3 Air conditioning

This auxiliary output option allows for a much more intelligent control of the vehicle's air conditioning compressor, as the FT600 controls its activation only when the engine is already on and the idle speed has stabilized and turns off the air conditioning when the valve exceeds a predetermined value (a resource commonly used in low-powered engines).

A/C button

In order to have the air conditioning control, the A/C button on the dashboard must be connected to a white input of FT600. The two connection options are:

A/C button positive when ON

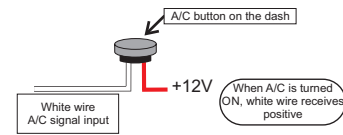

A/C button negative when ON

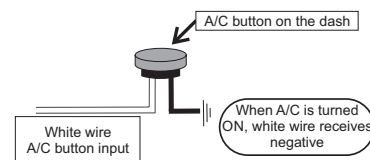

The air conditioning will remain turned on as long as the A/C Signal Input receives signal from the button. The signal polarity can be chosen and it varies depending on the installation.

A/C Compressor

A/C compressor must be controlled with a relay, triggered by an auxiliary output (sends negative when activated).

The auxiliary output that was setup as A/C will activate the A/C compressor relay and the A/C fan. For more information on how to setup this output, check chapter 13.

13.4 Shift Alert

This function activates an external shift light and works by sending negative when turned on. Any of the options below can be used:

- 12V light bulb up to 5W: switched 12V directly connected to the light bulb and the negative connected to the auxiliary output.
- Light bulb over 5W: use a relay to switch the light bulb.
- LED working as a Shift Light, which must be connected with a serial resistance (if used in 12V, resistance from 390Ω to 1kΩ) to the switched 12V.
- Any "Pen" Shift Light – working in the same way as a light bulb.

13.5 Fuel pump

The fuel pump control must be done through a relay sized in accordance to the pump's working current. The output sends out negative to activate the relay, which stays activated for 6 seconds and turns itself off if the ECU does not receive any RPM signal. When the ECU reads RPM signal, it activates the fuel pump once again.

13.6 Variable camshaft control/Powerglide gearbox

The camshaft control systems that use solenoid valve type NO/NC such as Honda's VTEC can be controlled through this output. The user only needs to inform the solenoid's turn on RPM.

It is important to notice that the impedance of the variable control system's solenoid must respect the auxiliary output limits, which

requires a minimum impedance of 25Ω, or the use of a relay. For valve timing control systems switched by PWM (such as Toyota's VVTi), it is possible to manage it through the Boost Control function, as long as its characteristics (power, current, etc.) are within the auxiliary output limits.

This resource can also be used to switch the control solenoid from the 2-speed automatic gear control, Powerglide type. Configure the RPM to turn on the solenoid responsible for engaging the second gear, only for drag racing applications.

13.7 Progressive nitrous control

This function drives the solenoids used for the injection of nitrous oxide in the engine.

As these solenoids have high power (90W) and low impedance (~1.6Ω), they cannot be connected directly to the auxiliary output. A solid state relay with appropriate max current and voltage must be used to power the nitro and fuel solenoids.

Set the output as progressive nitrous output.

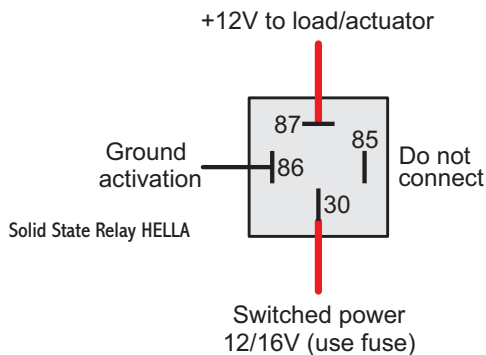

In the second option, the fogger only injects nitrous (dry nitrous). Fuel enrichment is managed by the injection, increasing injection times based on what has been programmed. The dry nitrous system has reached better results in tests, giving the engine a more linear power than the first option. It is important to clarify that in order to use the dry nitrous system, the fuel injectors must be correctly sized for the power maximum with the nitrous system operating.

There is a difference in the operation of solenoids that control nitrous injection and the ones that control fuel injection: nitrous solenoid starts pulsing after 5%; fuel solenoid only pulses after 20%. Variations may occur among solenoids from different brands/manufacturers.

When applying the conventional nitrous control, one must start with a minimum injection time of 20%, but when using dry nitrous, it is possible to start with 5%, as the injectors – and not the solenoid – will control fuel injection.

13.8 Boost Control – N75

This auxiliary output configuration allows the driving of a boost pressure control solenoid. FuelTech recommends using a 3-way N75 solenoid, found in the original 4 and 5-cylinder VW/Audi Turbo models, which can be directly switched through the auxiliary output. Such solenoid valve controls the pressure on the top and bottom parts of the wastegate valve, changing the engine manifold pressure with which the latter opens.



N75 Solenoid Valve
VW 058-906-283F

Wastegate at the exhaust manifold

This type of valve is used on most cars with adapted turbo, in competitions, etc.

Example 1: the first way to install a boost valve is connecting it to the bottom of wastegate valve, similar to the OEM installing in the VW 1.8T. Select the output signal as activated at 0V and frequency at 20Hz.

This way the boost valve will decrease the pressure under the wastegate to increase boost pressure.

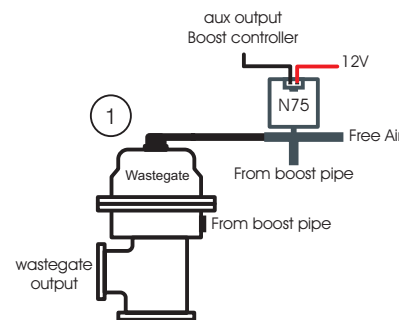

Example 2: the second way is to connect the boost solenoid to the top of wastegate.

Select the output signal as activated at 12V and frequency at 20Hz. This way, the boost valve will increase the pressure at the top of wastegate to increase boost

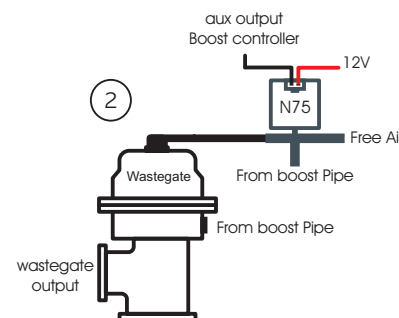

Wastegate integrated to the turbine

This valve has a different operation system, as it relieves the boost pressure when pressure is put on its top part, which is the opposite of what happens to the wastegate installed at the exhaust manifold.

Select the output signal as activated at 0V and frequency at 20Hz
With this kind of wastegate, the boost valve relieves the pressure in top of wastegate to increase boost pressure

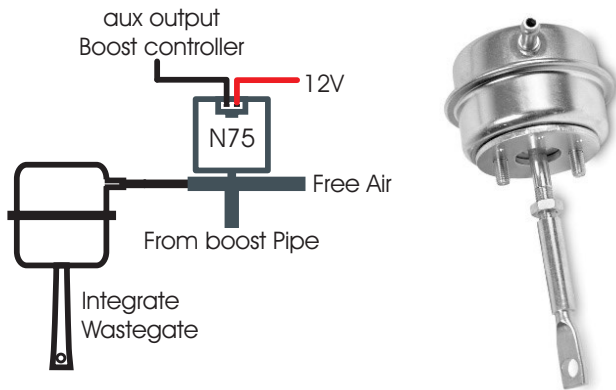

13.9 BoostController

The BoostController is used for more precise control of the turbo pressure in street cars, circuit and drag races. The control can be performed by time after 2-step, RPM and gear, gear and time after change, unique value and engine RPM, as well as the control with specific targets for drag race (2-step, 3-step and burnout).

See more information in chapter 19.15 BoostController diagrams.

14. Electronic throttle control

Electrical installation of an electronic throttle on FT600 is pretty simple. Check the example diagram below:

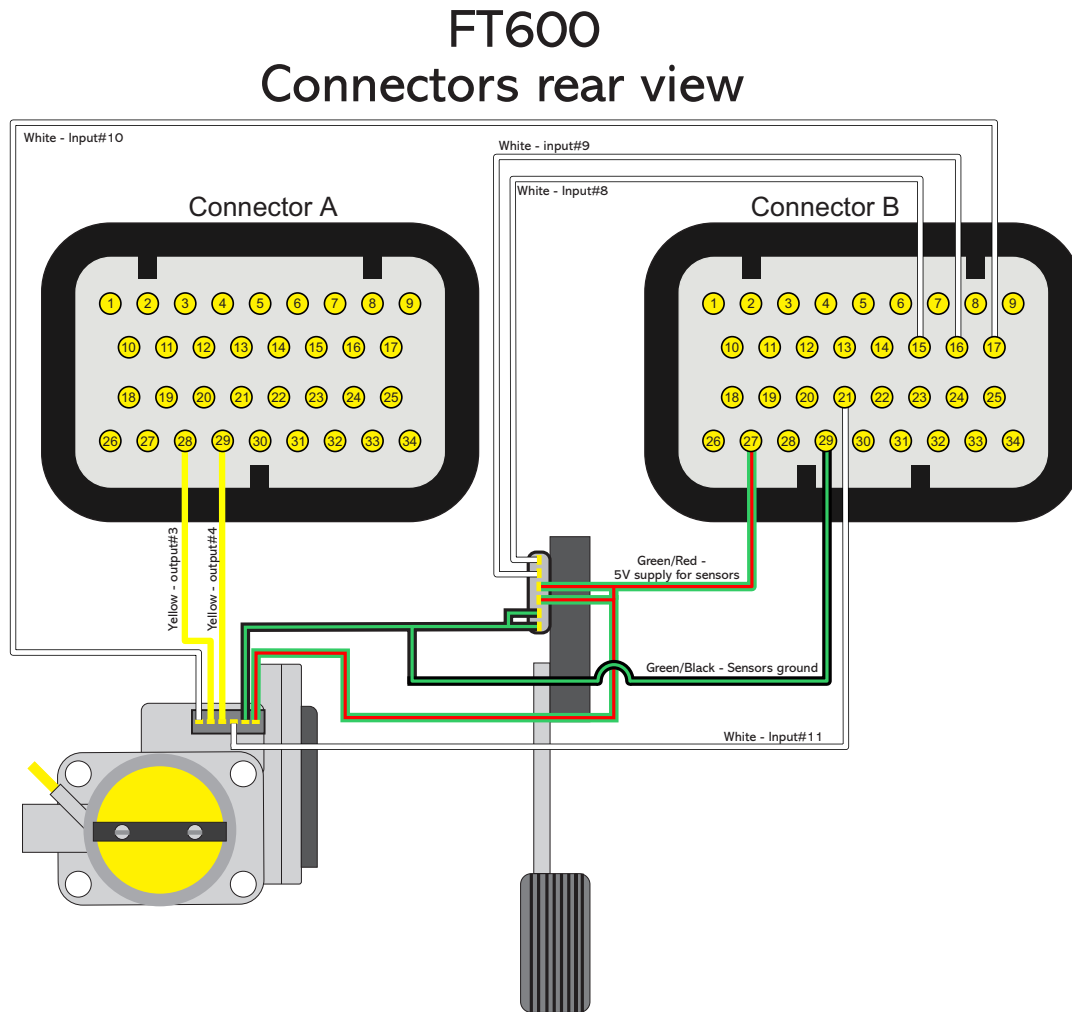

- **Yellow wire #3** (pin 13 of the connector A) must be connected to the throttle input corresponding to the Motor 1 input.
- **Yellow wire #4** (pin 14 of the connector A) must be connected to the throttle input corresponding to the Motor 1 input.
- **Green/red wire** (connector B) is and 5V output used to feed throttle and pedal position sensors. It must be spliced and connected to both of them.
- Sensors negative can also be spliced between pedal and throttle position sensors. Connect it directly to the battery's negative terminal.
- White numbered wires are sensors signal inputs, connect them to the signal outputs of the pedal (Pedal 1 and Pedal 2) and throttle (TPS1 and TPS2). After connecting these inputs, it is necessary to calibrate throttle and pedal as guides chapter 15.1.
- Pins 26 and 27 (connector A), yellow wires, will not be used for electronic throttle control, they can be set up as auxiliary outputs..

14.1 Connection table – throttle bodies and pedals

Check the throttle and pedal wiring before disconnect it from the OEM ECU. If you need, contact our tech support to get more information about throttles and pedals.

With the electrical connections ready, go back to chapter 7.5 and insert the throttle code (FT) that you found on the throttle table connection

If your throttle is not listed in our table, it might be necessary to send it to our tech team to have them check compatibility and research its control parameters. In this case please contact our tech support.

15. Sensors and Calibration

This chapter has the final steps before the first engine start. It basically guides the user through checking sensor readings and calibrating engine actuators.

15.1 TPS calibration



IMPORTANT:

To perform this calibration, it is very important that the engine is not running, because the throttle is fully opened and closed

Through FTManager, click in the TPS/Pedal button

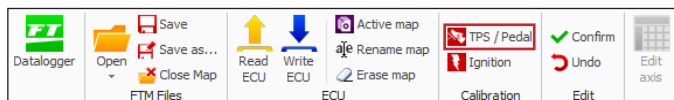

Go to "Sensors and calibrations" and then "Calibrate throttle/pedal".

1. With the pedal on idle position, click button "calibrate" besides the field "Idle: 0%
2. Push throttle to the maximum and click "calibrate" button besides the field "WOT: 100%".
3. Press "Save". Message "Calibration done!" is shown if the process is ok.
4. In case an error message is shown, check TPS connections.

TPS calibration errors may be:

Inverted and calibrated: means the TPS is connected the wrong way, but is normally working. If wanted, check connections, but, know that it will work normally connected this way.

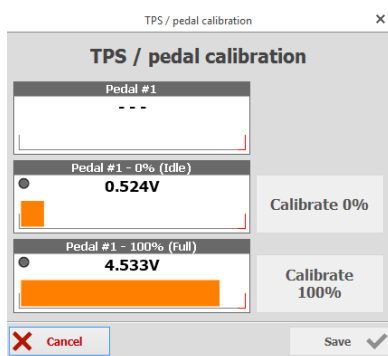

Possibly disconnected: check TPS connections. Maybe there is a broken wire or one of the connectors does not reach the TPS pins. Check with a tester to see if the voltage on the orange wire varies according to the throttle position.



TPS sensor must be calibrated on the first time the ECU is turned on only, and should be recalibrated only when it has to be replaced or the throttle opening on idle was changed. TPS calibrations are individual by map file.

TPS signal voltage must go up, as the pedal is pressed, and must have at least a 3V difference between the idle and WOT positions

TPS errors and diagnostics

Error message	Diagnostic
TPS range must be higher than 1.5 Volts	The TPS value from 0% to 100% has a smaller difference than 1,5V
TPS signal may be shorted to ground	Ground short circuit for TPS input
TPS signal may be disconnected	TPS input disconnected or short circuited to 5V
TPS calibration is required only when activated	No input configured as TPS.

15.2 Electronic throttle/pedal calibration



IMPORTANT:

Every time the pedal calibration is done the throttle automatically calibrates its opening limits. It is very important that during this calibration the engine is turned off because the throttle is fully opened and closed.

This calibration procedure is exactly the same as the mechanical throttle calibration. The only difference is that the calibration screen shows voltage value on both TPSs of the electronic pedal.

With this done, it is necessary to adjust idle speed control parameters as guides chapter 19.2

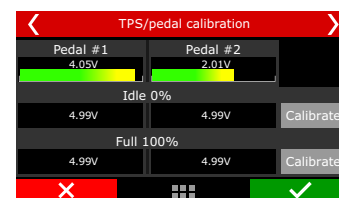

Throttle body error and diagnostic messages

Error Message	Diagnostic
Throttle #1 channels not found	There is no input configured as throttle input
ETC motor #1 signals may be disconnected	ECU Failed to actuate the throttle motor
Throttle #1A signal may be shorted to ground	Throttle Input A short circuited to GND
Throttle #1A signal may be disconnected	Throttle input A disconnected or short circuited to 5V
Throttle #1B signal may be shorted to ground	Throttle Input A short circuited to GND
Throttle #1B signal may be disconnected	Throttle input A disconnected or short circuited to 5V
ETC 1 code error	Throttle code error

15.3 Fuel/oil pressure sensors inputs

In this menu are the settings for fuel and pressure sensors. There is a predefined configuration for PS-150/300/1500 pressure sensors, but any kind of analog sensor with 0-5V signal can be used. This configuration is done through the PC and software FTManager.

In case there is a reading error between the FT600 screen and the real value of the sensor (comparing to an external gauge), this compensation is easily done by adjusting the sensor offset. It is possible to edit this compensation in mV or in pressure offset. Just change the button on the top part of the screen between "Input value" (mV adjust) and "Output value" (pressure offset). The field "Read value" shows readings in real time.

Make sure your external gauge is correctly calibrated and that the correct sensor is selected, as incorrect use of this function can cause significant error in pressures reported.

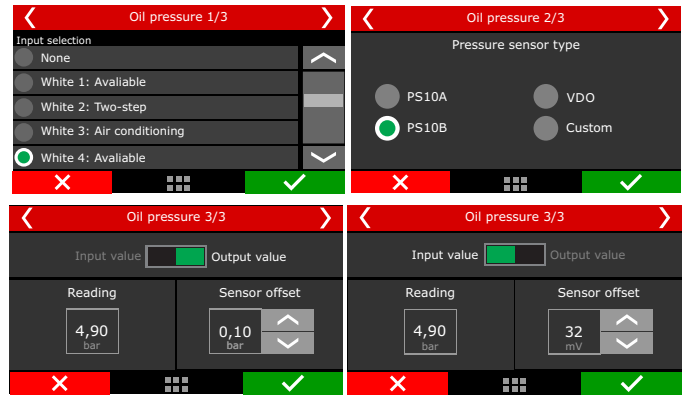
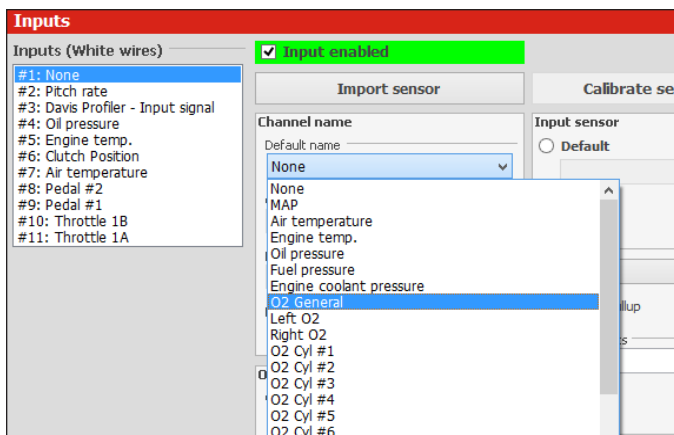

The FT600 has fully customizable inputs, which allows to read any 0-5V analog pressure sensor, since its pressure vs voltage table is known. In this case, just select the custom option and fill the interpolation table through FTManager.

15.4 Intake air and engine temperature sensors

In this menu are the settings for intake air and engine temperature sensors. There is a predefined configuration for GM and Fiat sensors.

In case there is a reading error between the FT600 and the real value of the sensor (comparing to an external gauge or to the dashboard), this compensation is easily done by adjusting the sensor offset. It is possible to edit this compensation in mV or in degrees. Just change the button on the top part of the screen between "Input value" (mV adjust) and "Output value" (temperature offset). The field "Read value" shows readings in real time.

Make sure your external gauge or dashboard is correctly calibrated and that the correct sensor is selected, as incorrect use of this option can cause significant error in reported temperatures and possible engine damage

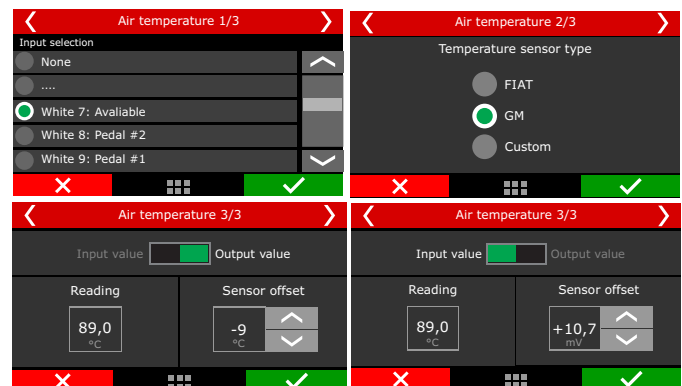
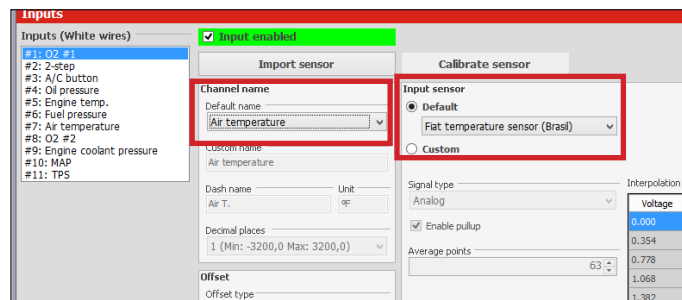

The FT600 has fully customizable inputs, which allows to read any 0-5V analog temperature sensor, since its temperature vs voltage table is known. In this case, just select the custom option and fill the interpolation table through FTManager.

15.5 O2 sensor inputs

O2 sensor signal input can be setup on any sensors input of this FT600 it is even possible to read fifteen O2 sensors simultaneously and show them on the screen. For wide band O2 sensors, it is necessary to use a wide band conditioner, for narrow band O2 sensors, direct connection is allowed.

Be sure to connect the O2 conditioner to FT600 according to the Chapter 12.7 of this manual.

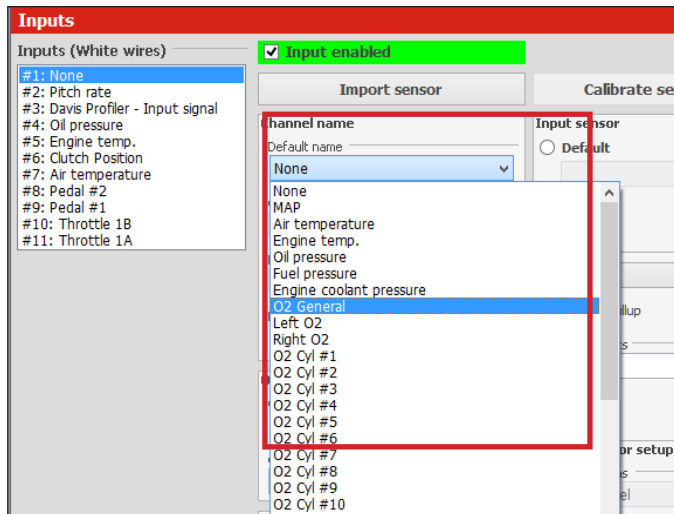

CAN network reading

Through CAN network the reading is sent directly to FT600, the only configuration necessary is to indicate what is the position of each sensor, this procedure is called "association".

The association procedure is executed by disconnecting from the conditioner a single sensor at time, this way the FT600 identifies and associates that sensor to the position of the engine (cylinder 1, general O2 sensor).

Follow the steps and repeat for each O2 sensor:

1. Keep the conditioner connected and turned on and disconnect the O2 sensor;
2. Press the Associate button on FT600 or on the "CAN communication of FTManager" window;
3. Reconnect the O2 sensor and repeat the process to all other O2 sensor;

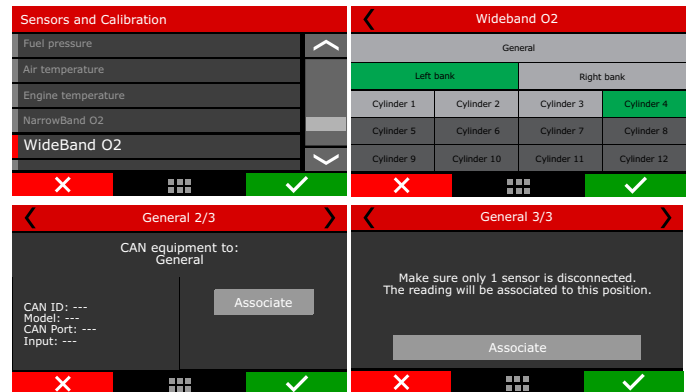
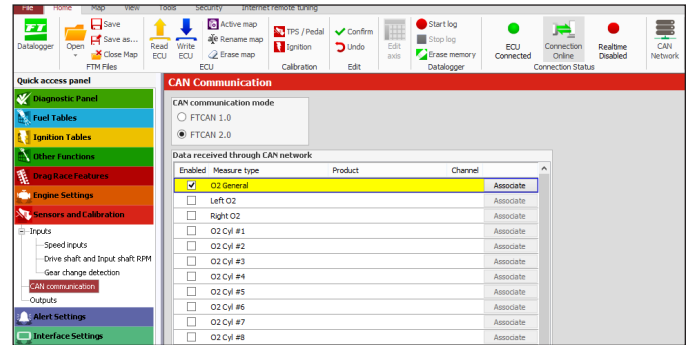

Analog input reading

The O2 sensor reading through an analog input is used either to narrow band or wide band with conditioners that have analog output (FuelTech WB-O2 Slim WB-O2 Nano WB-O2 Datalogger and Alcohol O2), Simply set the sensor in any input of FT600 (white wires).

It's necessary to set the input scale according to the analog output of conditioner used. If it's a FuelTech conditioner select one of the preset scales. For other manufacturers use the custom table. The narrow band sensor reading is displayed directly in Volts.

Analog scales compatible with the FT are:

Scale	Output voltage
0,35 - 1,20	0,35 = 0,2V - 1,20 = 4,8V
0,59 - 1,10	0,59 = 0,2V - 1,10 = 4,8V
0,65 - 1,30	0,65 = 0,2V - 1,30 = 4,8V
0,65 - 4,00	0,65 = 0,2V - 4,00 = 4,8V
0,65 - 9,99	0,65 = 0,2V - 9,99 = 4,8V

WB-O2 Nano, Slim or Datalogger calibration

Offset calibration is needed to compensate analog signal loss. With O2 sensor connected and configured go to "Calibrate O2 sensor" (through display) or click in "Calibrate sensor" in FTManager software. To calibrate O2 sensor, proceed as follows:

1. Check the scale of FT600 with external conditioner, they must be equal.
2. With the engine running, stabilize the O2 reading.
3. Adjust the offset until the reading in the conditioner matches the reading in the ECU.



4. If the calibration and configuration are correct, there will be no reading difference.

NOTICE:
If the difference is greater than 0.02 between the readings, it means that the scales are different.

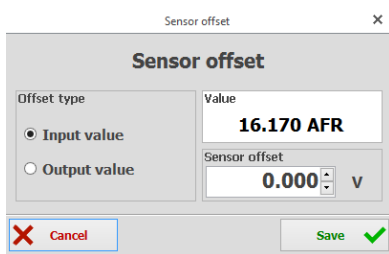
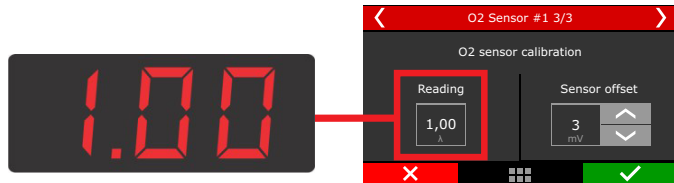

Alcohol-O2 Calibration

Also called free air calibration, this calibration is necessary when using FuelTech Alcohol O2 conditioner to compensate for differences in each sensor. When replacing a sensor it's necessary to repeat this calibration.

1. Remove the sensor from the exhaust pipe and let it ventilate for at least 20 seconds;
2. Press the calibrate button;
3. Calibration is ok;

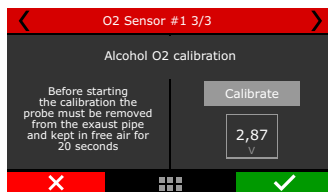

15.6 Speed inputs

In the FTManager, there is a menu with all the settings related to wheel speed reading. In the touchscreen, the settings are divided in a few submenus and will be presented in the next chapters.

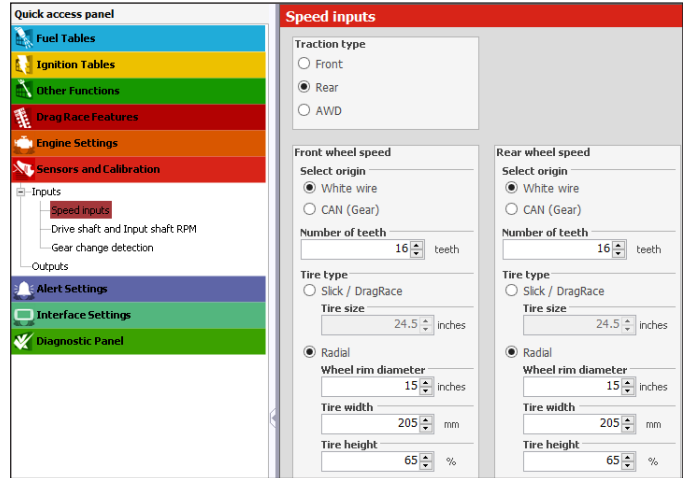

Traction type

Set here if the vehicle is FWD, RWD or AWD. This information is used with the time based speed control.

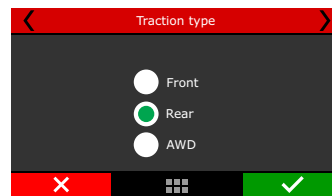

Wheel speed (front/rear)

This menu gathers the wheel speed (front and rear) reading setup. In the first screen, set if the reading is through FT600 sensor input (white wire) or through FuelTech GearController CAN port.

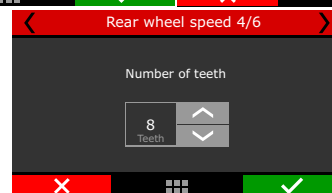
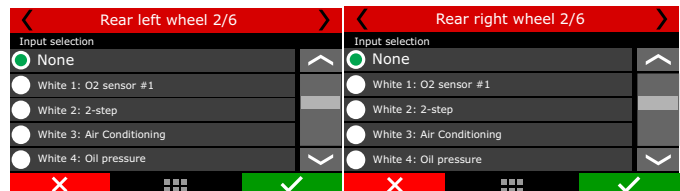
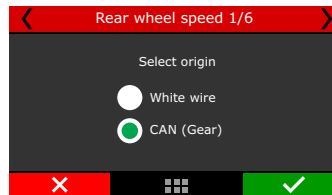

The last setting is related to tire type and size. Slick/Drag Race tires only require the wheel rim diameter. Radial tires require wheel rim diameter, tire width and height.

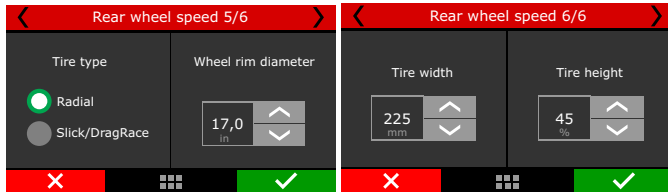

15.7 Driveshaft RPM and Input shaft RPM

In the FTManager, there is a menu with all the settings related to driveshaft RPM and input shaft RPM reading. In the touchscreen, the settings are divided in a few submenus and will be presented in the next chapters.

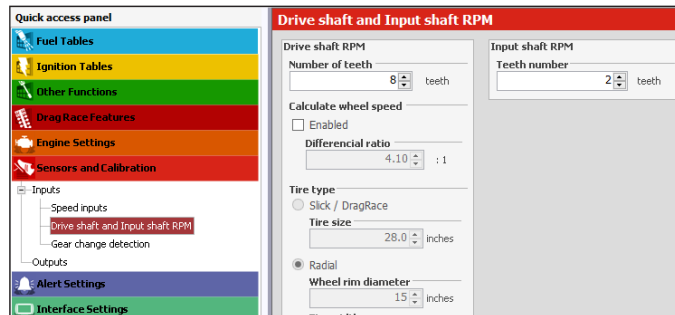

15.8 Driveshaft RPM

This menu is used to setup the driveshaft RPM reading. Select the FT600 sensor input to be used and insert the trigger wheel number of teeth



With the driveshaft speed and the tire dimensions, it is possible to calculate the traction wheel speed. If you want to use a driveshaft RPM sensor instead of a wheel speed sensor, check the box "Calculate wheel speed" in the next screen.

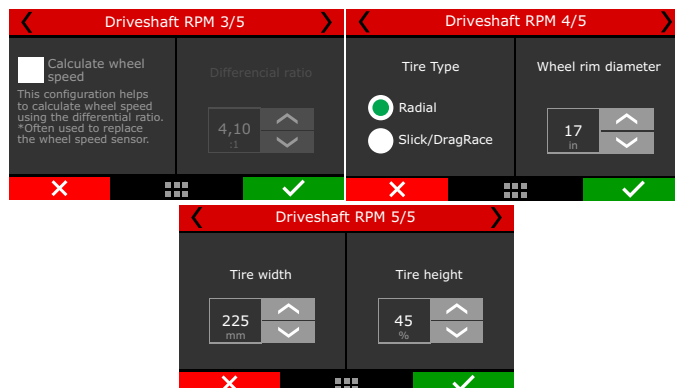

To calculate wheel speed, insert the differential ratio and tire dimensions.

The last setting is related to tire type and size. Slick/Drag Race tires only require the wheel rim diameter. Radial tires require wheel rim diameter, tire width and height.

15.9 Gearbox RPM

This feature allows the gearbox input shaft RPM Reading. The reading is very useful to analyze the clutch/torque converter slip. Just insert the sensor input and the number of teeth

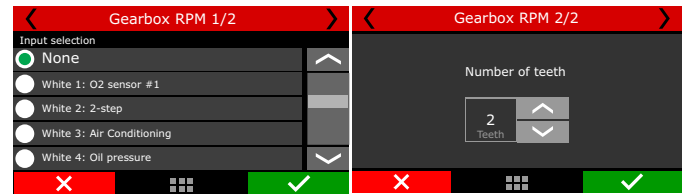

15.10 Gear detection

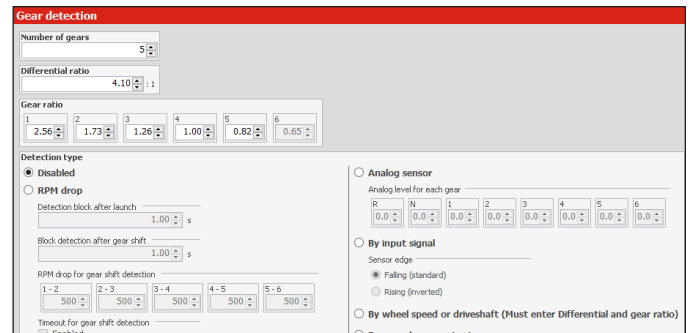

In this menu there are the settings related to gear detection change (display and log). There are 5 different ways to detect it: by RPM drop (drag race only), by gear position sensor (requires a sensor in the transmission), by interpolating the current wheel speed versus engine RPM, by pulse and by gear shift output.

To view the currently engaged gear in the FT600 dashboard, go to "Interface Settings" and then "Dashboard Settings". Once in, click in the cell where you want to display the gear and select "Gear".

The first mode, by RPM drop, must be used only in drag race cars, since it can only detect upshifts and not down shifts. The third screen is for safety configurations, used to prevent false gear detection due to traction loss. Default values are good to most cases.

The fourth screen is for the RPM drop programming to each gear. The fifth screen is to enable and program the timeout for gear shift detection that is another safety feature to prevent false detection.

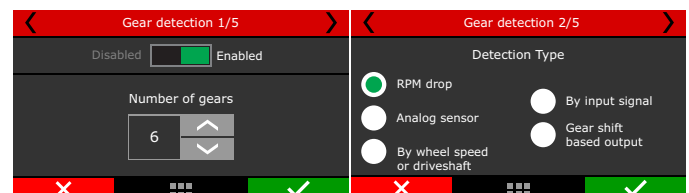

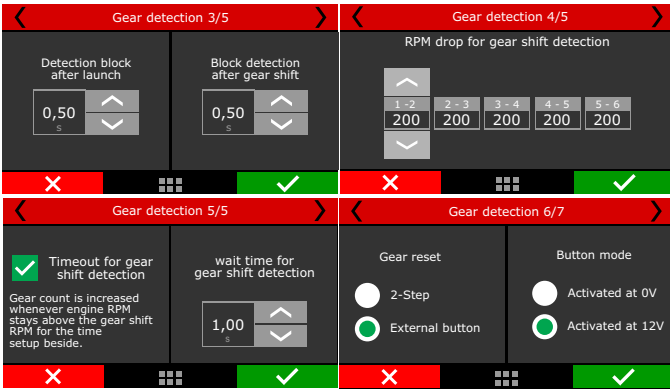

The second mode reads an analog gear position sensor, which is a potentiometer that indicates the engaged gear in transmissions already equipped with this sensor. Select the input that will read the sensor signal and then configure each gear voltage

To find the gear voltage, use a multimeter, in 20VDC scale, connected to the output of the gear position sensor and engage a gear at a time.

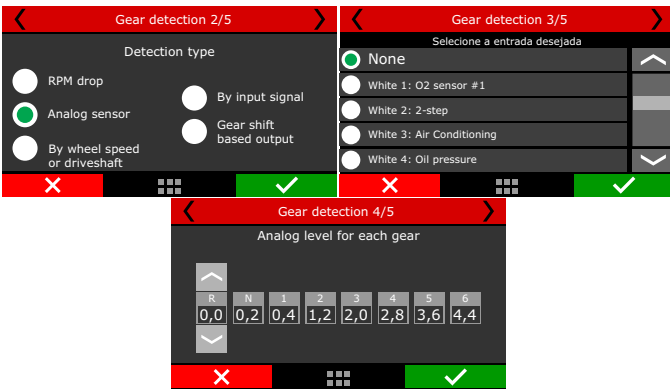

The third mode crosses the wheel speed and RPM to calculate the engaged gear.

To configure, set the number of gears, gearbox ratio and differential ratio.

This detection mode will only show the engaged gear if the vehicle is moving and there is wheel speed reading.

When the clutch is pressed or the gear is disengaged (neutral) momentary misreading may occur.

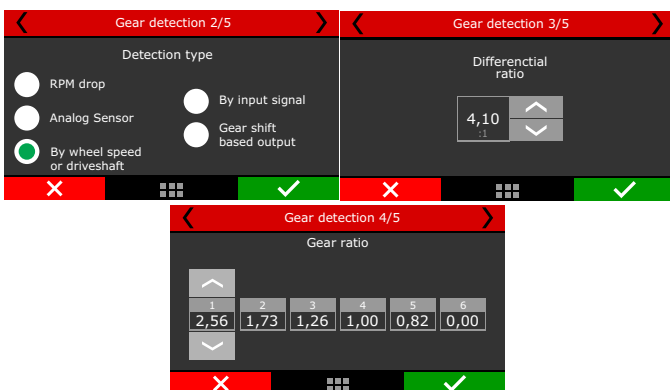

The fourth mode increases the gear counting by each pulse received on a white input. Set in which edge the count should be increased (default: falling edge). Configure an input as “Gear Detection” and connect the device that will send the pulse to increase the counting. This mode cannot detect down shifts and requires the 2-step to be used to reset the counter; therefore it is best suited for drag race cars.

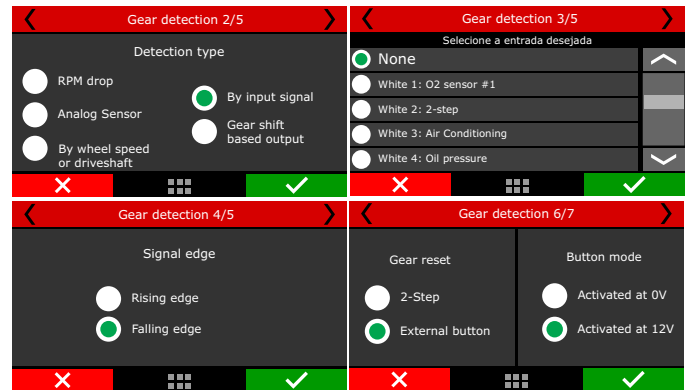

The fifth mode enables an internal counter that is increased by each pulse sent out by the Gear shift output (Drag Race Features menu). This mode cannot detect down shifts and requires the 2-step to be used to reset the counter; therefore it is best suited for drag race cars.

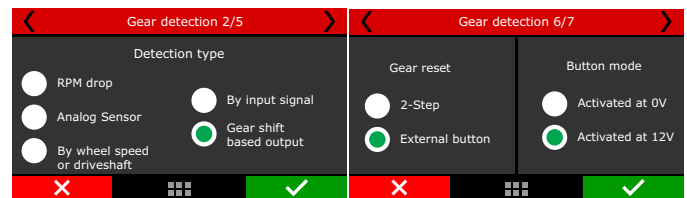

15.11 Nitrous bottle pressure

This menu gathers the settings to read nitrous bottle pressure. This way is possible do compensate fuel according to the bottle pressure. To read the bottle pressure you must use a PS1500 sensor or a similar one.

15.12 Clutch position

In this menu are the settings to read the clutch position. A potentiometer must be used, similar to a TPS. After the wiring done, the calibration is required.

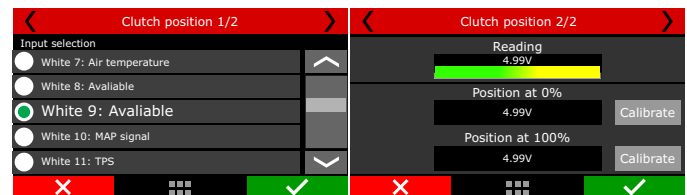

15.13 Clutch pressure

This function allows to measure the pressure of the liquid on hydraulic assisted clutches. To read the pressure, use a PS1500 sensor or a similar one.

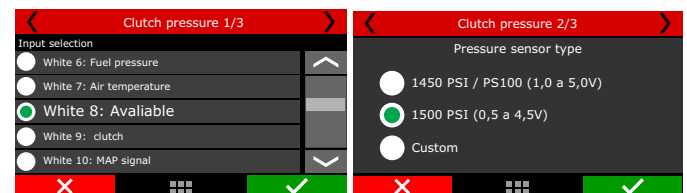

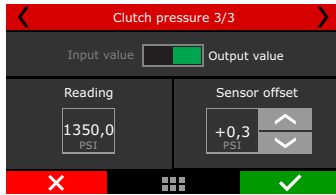

15.14 Ride Height

This function allows to read the front end height from the ground. The wheelie control is based on this input and you can find more on this at Chapter 20.9. Normally, a laser height sensor is used.



15.15 Pitch Rate

This function reads the rate at the front end pitches and is given by degrees per second.

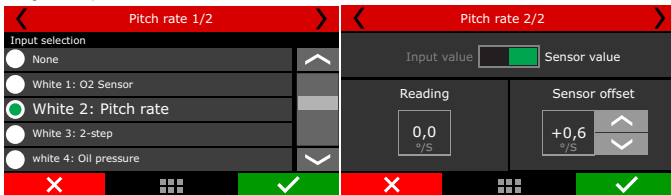

Through FTManager, all the sensors above can be configured in the "Sensors and Calibration" menu, then "Inputs".

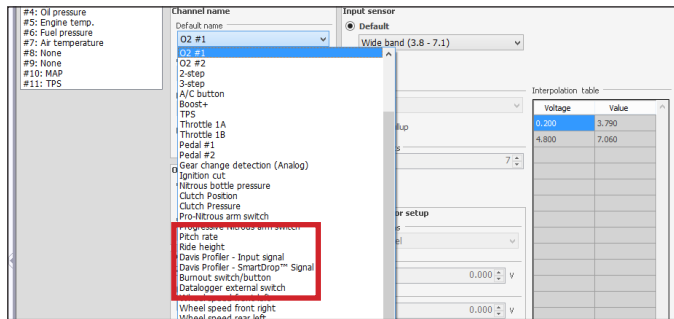

15.16 CAN communication

In this menu is possible to configure all the equipment connected to the CAN network. There are 2 different CAN protocols. Below is the compatibility of each protocol:

- FT CAN 1.0: GearController (until V2.17), BoostController, KnockMeter, Racepak IQ3 and AiM Dashes;
- FT CAN 2.0: GearController (after V2.20) EGT-8 CAN; WB-O2 Nano and WB-O2 Slim;

CAN network supports up to 32 sensors of each product.

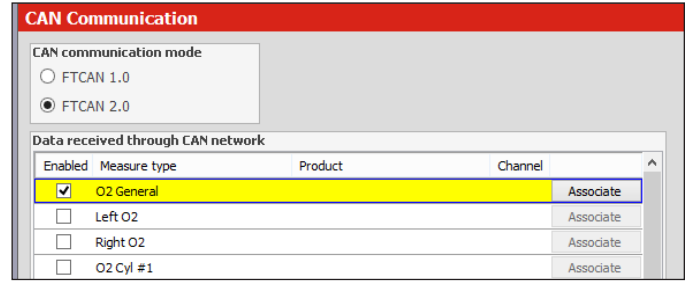
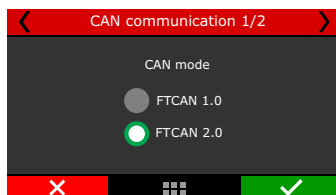

15.17 EGT

This menu allows to setup the EGT conditioners (ETM-1 or EGT-8 CAN) and to perform the cylinder attribution. To do it, simply select the cylinder where the EGT is placed and what is the conditioner.

The attribution can be done using the CAN network with EGT-8 CAN or using the white wires inputs with ETM-1.



EGT-8 Settings

Since update 3.3 there is a new layout for setting the EGT-8 channels. Access "sensors and Calibration / CAN Communication / EGT-8" an image of the EGT-8 will be displayed, click on the channel you want to configure and select which sensor from the list will be associated with this channel.

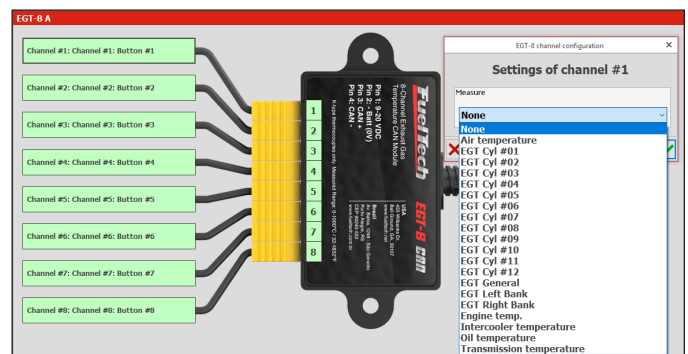

SwitchPanel-8 Configuration

This is an external panel with 8 buttons that are totally configurable through FTManager via CAN Communication. Go to "Sensors and Calibration / CAN Communication / SwitchPanel-8" click on the button you want to configure and select one of the many preset functions from the list.

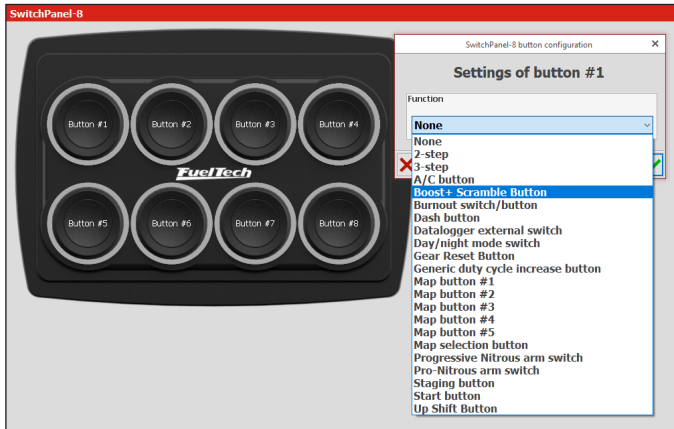

15.18 Wastegate Pressure

Setup the wastegate pressure sensor for use with the integrated BoostController. For more information check chapter 19.16 BoostController.

15.19 Internal accelerometer

After the FT600 installation, the accelerometer calibration is needed to avoid errors. It can be performed directly through the FT600 screen or through the PC Software FTManager.



To perform the calibration, simply fix the ECU on it's place and click the "Calibrate" button. The current position on the car will be saved the default. If you wish to reset calibration, used the "Reset Calibration" button.

There is even an accelerometer bias error used to correct mirror read errors.

Accelerometer Bias Error: to set this bias is necessary to compare the acceleration speed with front and rear wheel speed, the difference will be the bias configuration.

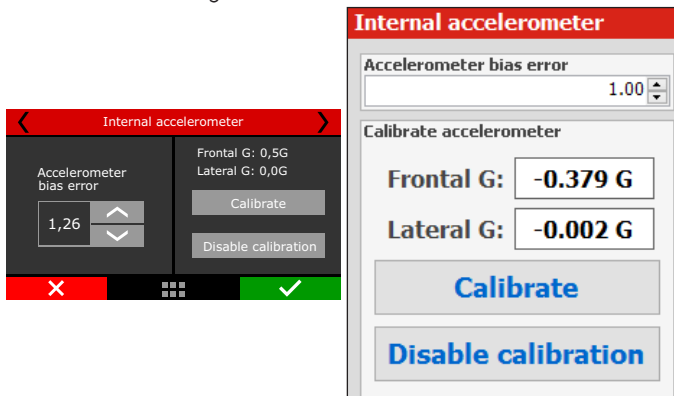

Filter frequency: this filter is applied to the accelerometer to decrease signal noise, resulting in a cleaner signal.



IMPORTANT:

A greater filter frequency will result in signal reading delay.

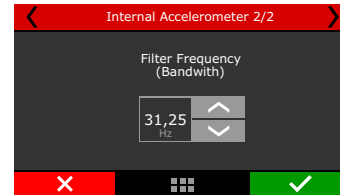

15.20 Brake Pressure

This function configures a sensor input for brake pressure control, helping the line lock function.

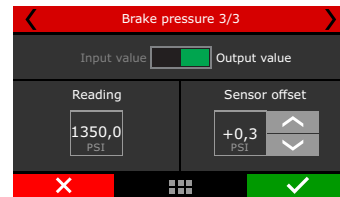
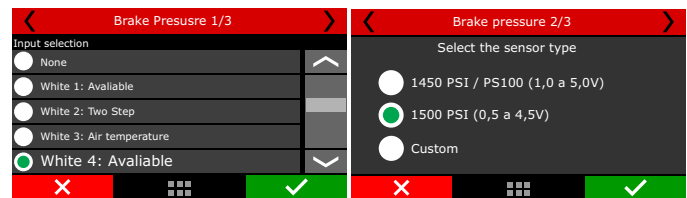

15.21 Front and rear shocks

This function allows to set the range for the sensor used on each wheel to measure suspension travel.

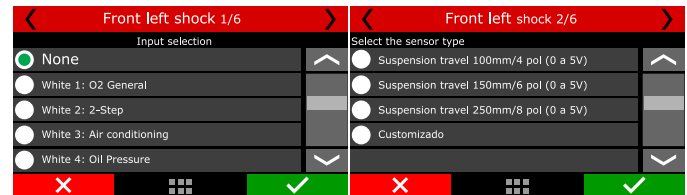

15.22 Flex Fuel

This function allows the use of a GM Flex Fuel sensor to measure the ethanol density that the gasoline has on the fuel line.

15.23 CounterPressure

This function allows to set up a pressure sensor to be used on the exhaust to measure back pressure.

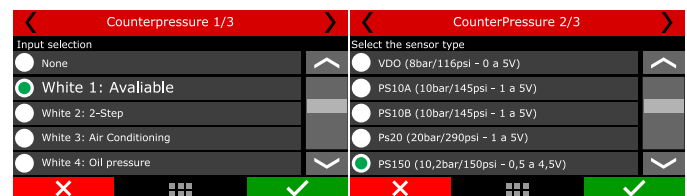

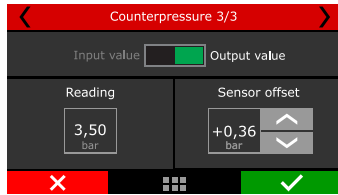

15.24 Oil pan pressure

Used to measure pressure inside the oil pan.

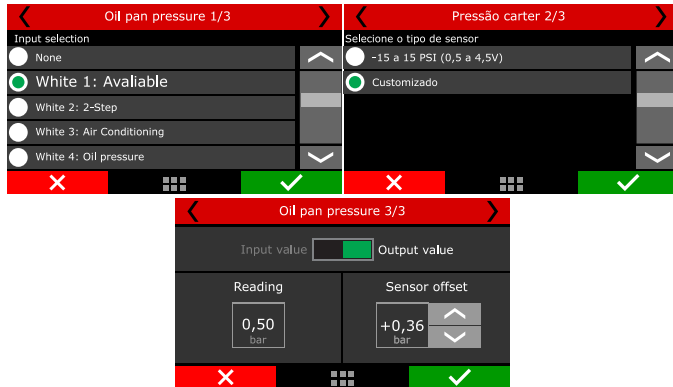

15.25 Transmission pressure

Monitors the pressure inside the transmission.

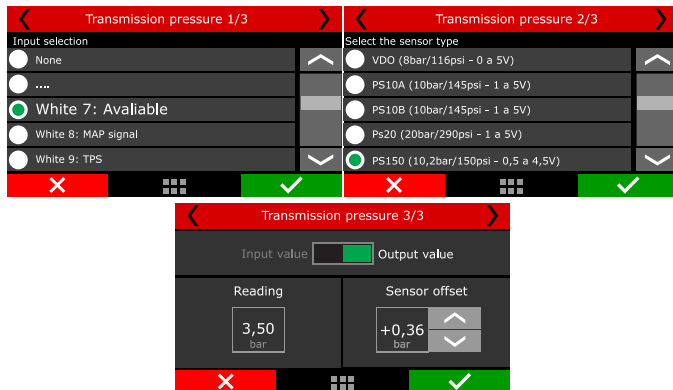

15.26 Transmission temperature

Allows to set a sensor to measure the oil temperature

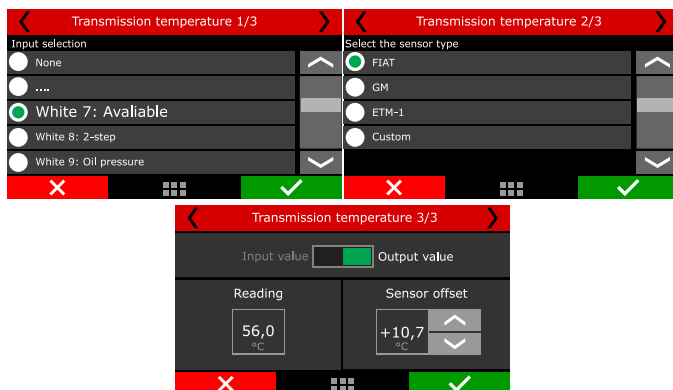

15.27 Torque converter pressure

This function allows to set up a pressure sensor to be used to measure torque converter pressure.

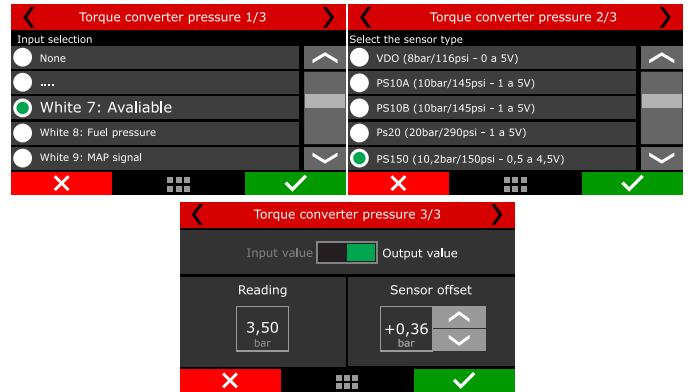

15.28 Intercooler temperature

Used to monitor intercooler temperature.

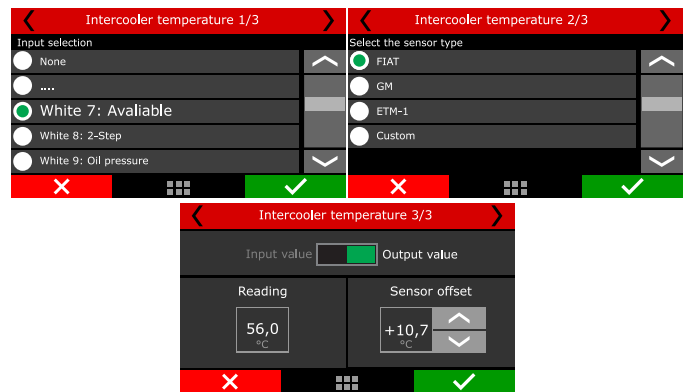

16. Starting the engine for the first time

This chapter shows final steps before the engine first start and guides the user through checking and calibrating all the sensors and actuators of the motor.

16.1 First engine start

Try not to push the starter motor and the coils by cranking the starter too long on the first start. Check if the fuel pump is turned on and if there is fuel pressure on the line. Check if the FT600 reads the correct RPM in its dashboard and make sure there's spark on the spark plugs (unplug the spark plug wires and install a spark plug on it to check for spark).

On engines fueled with ethanol or methanol, use gasoline on the throttle body to make the first start smooth.

When the engine starts, keep it at a fast idle and double check oil pressure and the coil and igniter temperature.

Check if the RPM is being correctly shown on the ECU display (if possible, compare to an external tachometer) and if throttle variations coincide with TPS and vacuum readings.

16.2 Ignition calibration

Once the engine has started, before any kind of test or tune, the ignition calibration must be performed. This calibration is very important to make sure the timing the ECU reads is really correct with the engine. This function locks the timing to 20° (or 0°) on any RPM, this means, if the engine starts but has no idle, you can rev it up and keep it in something around 2000rpm to perform the calibration. Avoid RPM variations as this causes variations on the timing light readings.



The access to this function is given by the "Ignition" button in the main FTManager menu or the "Calibrate ignition" in the touchscreen "Sensors and Calibration" menu

Ignition calibration with distributor: On the engines originally equipped with distributor, there's a TDC mark for cylinder #1. Point the timing light and turn the distributor until the timing light reads 20°. Lock the distributor then press "OK" button on the ECU. Ignition calibration is finished

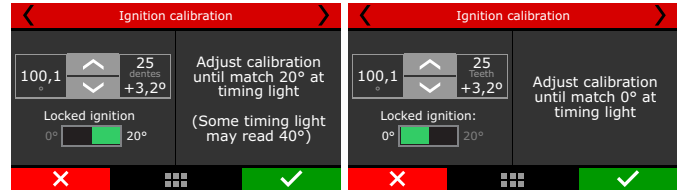
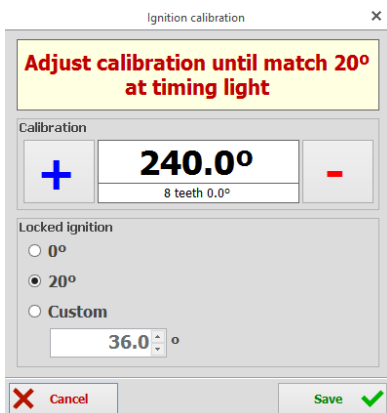

Ignition calibration with crank trigger: Cars originally equipped with crank triggers, usually do not have the TDC mark. This mark then should be done by stopping the engine on cylinder #1 TDC of compression using a dial-comparator. It is very important to be precise when making this timing mark; the slightest error will ultimately affect ignition timing on the engine

In these systems, usually the ignition is controlled on wasted spark, with one spark on the combustion stroke and one on the exhaust stroke. As the timing light reads both sparks, it usually shows 40° BTDC of timing, but the actual timing is 20° BTDC.

As it is not possible to turn the crank trigger as we do on distributor systems, the ignition calibration screen has a compensation that must be changed until the timing light shows 20° BTDC (or 40°, according to the timing light). Let's say you read a timing of 24° BTDC, a compensation of -4° is needed to read 20° BTDC on the crankshaft TDC mark. When the timing light is reading double the real timing (wasted spark), if the timing on the timing light is 46°, the compensation that must be set is -3°, instead of -6°.

To check if your timing light is reading twice the real timing, advance 5° and check the timing on the engine again. If the timing has advanced 10°, the timing light is reading double the real timing.

17. Fuel tables adjust

17.1 Main fuel table

Editing mode for main fuel table is on 2D basic mode by default, but it is possible to switch to advanced 3D mode. To change this parameters, in the FTManager, go "Advanced map options" in the "Engine settings" menu.

On FTManager, it is possible to edit the map cell ranges of MAP/TPS, RPM, etc., making it possible to increase the detail level on the maps where a fine tuning is needed. To do it, simply click on "Edit axis" on FTManager tool bar.



Basic Mode - 2D table

In the basic mode, the engine is tuned according to the MAP sensor or TPS. By default, the main fuel table by MAP is from -14.5psi up to the desired pressure.

When the main fuel table is by TPS, the table is from 0 to 100% in 10% steps.

Through FTManager, it is possible to use up to 32 cells, which will allow to have a better map and a fine tuning.

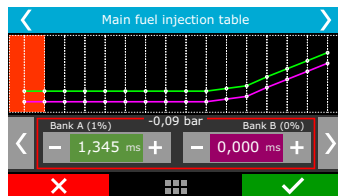
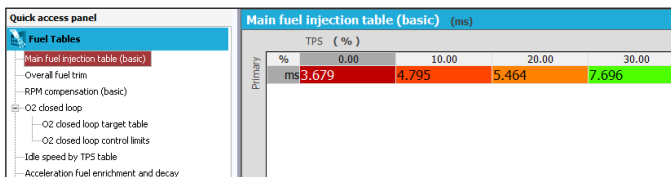

Advanced Mode - 3D table

In the advanced mode, the main fuel table is a 3D table, where the injection time is calculated according to the MAP sensor (or TPS) and engine RPM. As well as the basic mode, the MAP range is from -14.5psi up to the desired pressure. When the main fuel table is by TPS, the table is from 0 to 100% in 10% steps.

The default RPM steps are 200rpm until 3000rpm, and above this rpm the steps are in 500rpm. The MAP, TPS or RPM steps can be edited via FTManager.

		MAP (psi)												
		-11.60	-10.15	-8.70	-7.25	-5.80	-4.35	-2.90	-1.45	0.00	2.90	5.80	8.70	11.60
RPM (rpm)	8000	3.249	3.293	3.377	3.448	3.673	3.730	3.249	3.354	3.647	3.447	4.281	4.836	5.503
	7600	3.323	3.320	3.387	3.439	3.478	3.755	3.277	3.396	3.705	3.501	4.355	4.985	5.622
	7200	3.283	3.356	3.474	3.528	3.733	3.830	3.400	3.549	3.889	3.742	4.661	5.337	5.998
	6800	3.236	3.450	3.500	3.554	3.757	3.875	3.433	3.585	3.928	3.789	4.716	5.400	6.068
	6400	3.300	3.374	3.486	3.547	3.722	3.860	3.464	3.625	3.964	3.837	4.741	5.455	6.153
6000	3.294	3.387	3.483	3.551	3.697	3.855	3.505	2.676	3.048	3.992	4.893	5.640	6.371	

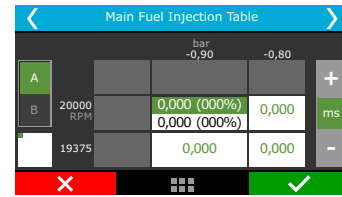

17.2 Overall fuel trim

The overall fuel trim recalculates and replaces all values of the main fuel table according to the percentage configured. This function can be accessed through "Fuel tables" menu.

When using individual banks, the trim will be available to each bank.

This compensation applies a percentage that can add or remove fuel from the main table (basic or advanced mode). For example, if in a certain cell the injection time is 2.000ms, representing 50% of injector opening at maximum rpm, and you apply 10% compensation, the result will be 2.100ms, representing 55% of injector opening, if the dead time is 1.000ms.

In all compensations the dead time must be discounted, so the value can be related to amount of fuel, instead of pulse width purely.

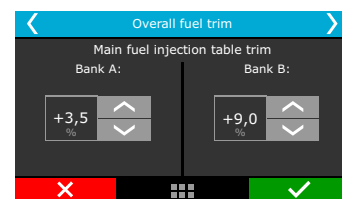
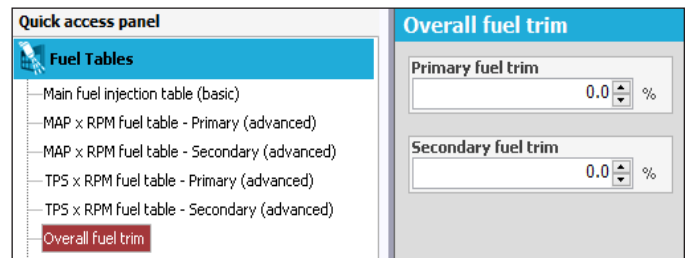

17.3 RPM compensation

This option is exclusive to the basic mode. The RPM compensation is a percentage compensation applied to the main fuel table. The calculation is automatically done considering the engine RPM and all the other compensations. This way, a 3D table is not necessary, which despite being more accurate, is harder than the basic mode and very often doesn't show a better result.

With the RPM compensation it is possible to have a good tune in any engine type, either a stock engine, race engine or with a variable camshaft (Honda VTEC, Toyota VVT-i, BMW Vanos, etc).

Every engine has a specific fuel consumption peak around the maximum torque rpm, so in the region additive compensation between 5 and 15% must be applied. In a stock engine the maximum torque is

normally between 2000rpm and 4500rpm, but to know exactly the rpm a dinamometer is required. Anyway, this compensation will be performed, because, to keep a constant AFR, more fuel will be needed at the maximum torque rpm.

With the main fuel table and the RPM compensation, the ECU generates internally a injection time vs load vs RPM table.

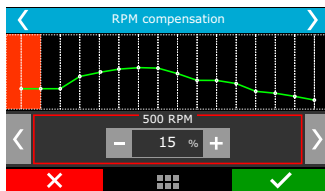
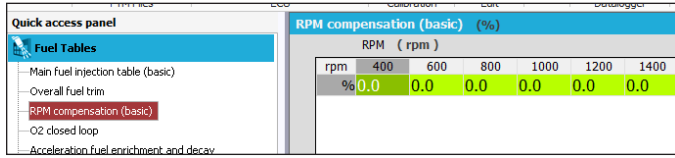

IMPORTANT

It is very important to check data continuity, avoiding incoherent values that may produce abrupt changes on the RPM graphic.

17.4 O2 Closed Loop

O2 closed loop reads O2 sensor and adds or removes fuel from the main fuel table in order to reach the O2 target set up.

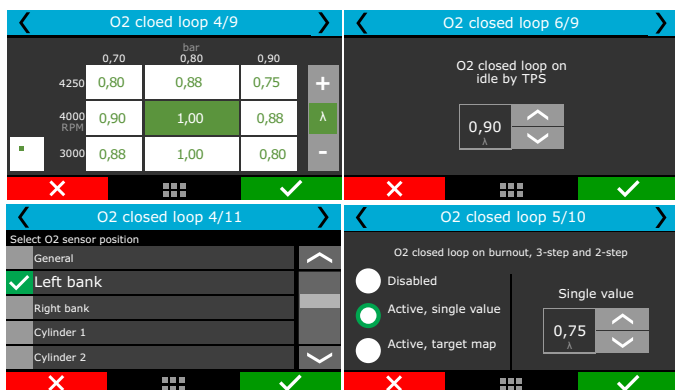
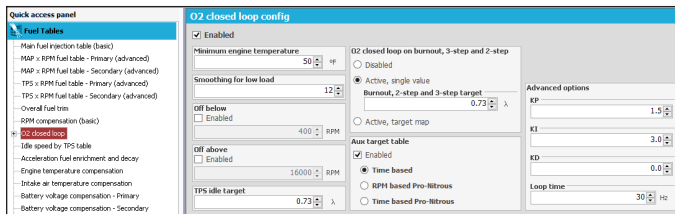

Low load smoothness is the speed control for low load situations like idle speed, where the O2 closed loop must reduce the compensation for O2 variations.

Engine temperature for control start is a temperature limit below which the O2 closed loop stays disabled and assumes the open loop fuel tables

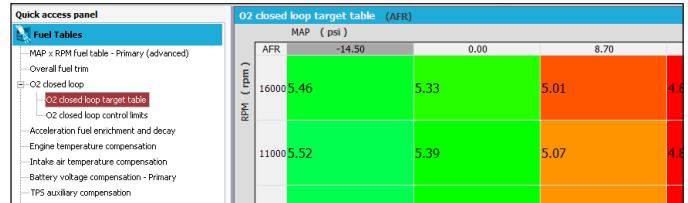

It is also possible to block the O2 closed loop under or above some RPM limits. The "Lock below" parameter is used, i.e., on engines where the O2 sensor is installed too close to the end of the exhaust, reading free air below a certain RPM. The "Lock above" parameter is a limit to disable the O2 closed loop and return to the open loop maps.

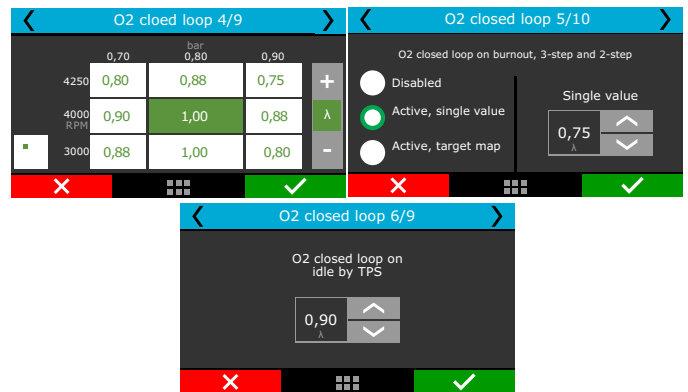

Next, is a 3D table of O2 closed loop targets versus RPM and MAP. It has up to 16x16 cells that can be edited through the PC Software.

There is also an option to setup a different O2 target for burnout mode, 3-step and 2-step. This target is a fixed value, no matter the RPM or MAP pressure.

The next screen (6/9) is only shown when the idle is TPS based. Set a target for idle condition (TPS=0%).

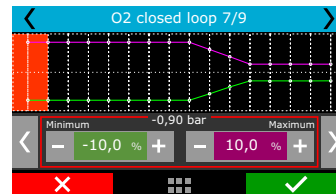

O2 closed loop control limits is a 16 points (8 columns and 2 lines) table, totally editable, by TPS or MAP, which defines the actuation limits of O2 closed loop, avoiding the control to remove or add too much fuel in certain situations.

Auxiliary O2 closed loop:

Aux by time (2-step):

This feature allows the creation of a 16 points time based O2 target table after the 2-step deactivation, which will overwrite the main O2 target table during the time setup on this auxiliary table. To trigger the 2-step, TPS must be above 50% or RPM must hit the 2-step rev limiter.

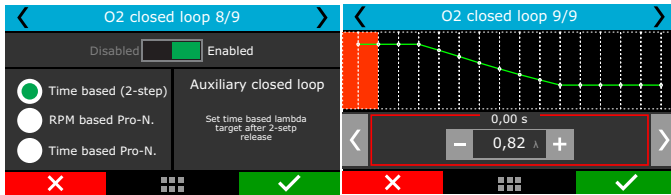

Aux Pro-Nitrous by RPM:

This feature allows the creation of a 16 points RPM based O2 target table to each Pro-Nitrous stage, which will overwrite the main O2 target table while the auxiliary control is on. This feature is only enabled when all Pro-Nitrous requirements are fulfilled.

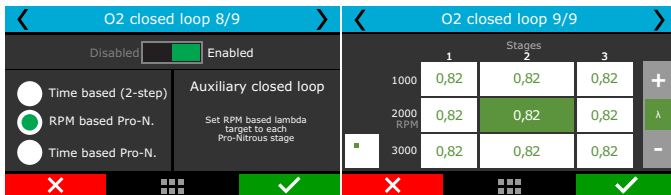

Aux Pro-Nitrous by time:

This feature is a 16 points time based O2 target table to each Pro-Nitrous stage, which will overwrite the main O2 target table while the auxiliary control is on. This feature is only enabled when all Pro-Nitrous requirements are fulfilled.

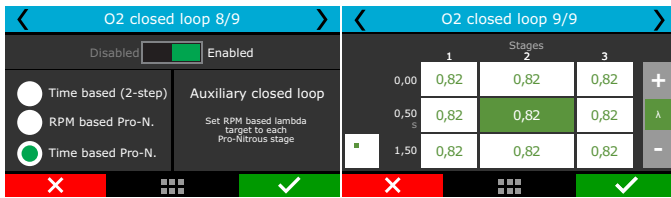

17.5 Idle speed by TPS table

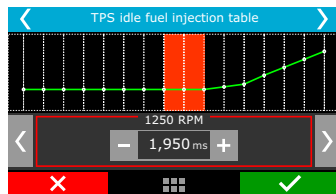
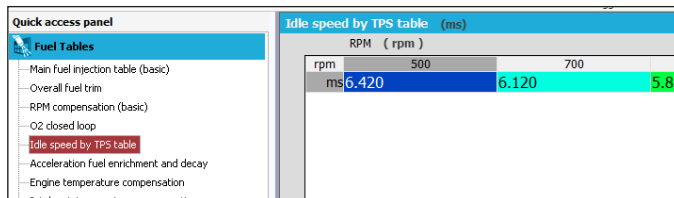

This menu is only available when the idle speed is set up by TPS. The injection time is adjusted according to the engine RPM.

17.6 Acceleration fuel enrichment and decay

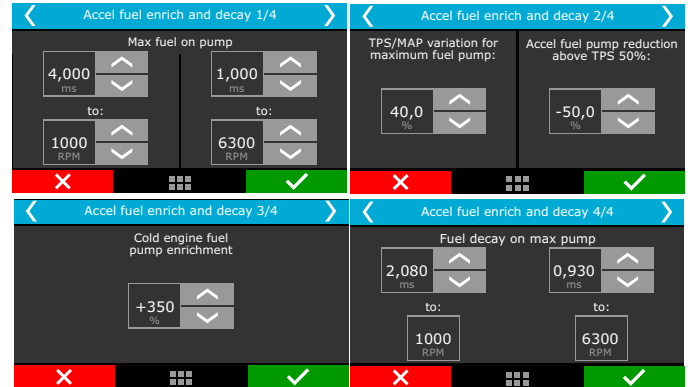
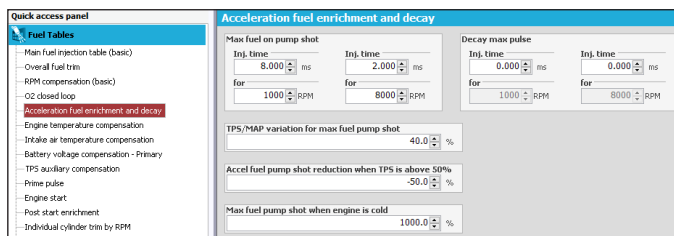

Acceleration enrichment is a fuel increase when the throttle is suddenly opened.

Max fuel on pump: value added to the actual injection time when a quick throttle variation is detected. There are two RPM and injection time parameters to be set. With them, the FT600 creates an acceleration fuel table that interpolates the values between these two positions.

TPS/MAP variation for maximum fuel pump shot: This configures the MAP or TPS variation for which the max fuel pump will be used. Engines equipped with small throttles usually need a higher TPS variation to need max fuel pump. In this case, use higher TPS values on this parameter (70-90%). For big diameter throttle bodies, a small TPS variation is enough to demand max fuel pump (around 15%). The TPS or MAP selection is done in the Engine Setup menu. If the TPS is not present, MAP must be chosen.

Accel fuel pump reduction above TPS 50%: due to reduced need of fuel when the acceleration fuel pump occurs with the throttle already opened above 50%, this parameter reduces the max fuel pump on this condition. By standard, the ECU reduces 50% of the max pump when it occurs above 50% of TPS.

Cold engine fuel pump enrichment: this is a simple increase on the max fuel pump value when the engine is cold, extremely needed on the first minutes of engine operation.

Fuel decay on max pump: this is the injection time that will be subtracted from the actual injection time during a sudden throttle closure. With this, in a fast throttle closing, is possible to remove fuel and have a more stable AFR during deceleration.

17.7 Engine temperature compensation

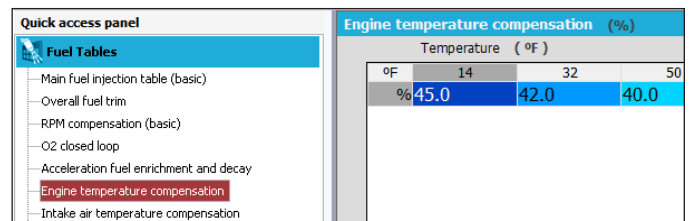

Engine temperature greatly influences the amount of fuel requested by engine, especially in cars run with ethanol and methanol, when it is possible to operate a cold engine as if it had already reached normal temperatures.

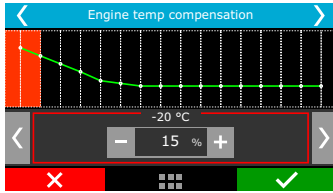

This compensation is applied based on the engine temperature sensor, which, in water-cooled cars, must be at the cylinder head reading the water temperature, and in air-cooled engines, must be reading the oil temperature.

Compensations based on engine temperature are only available when the sensor is connected to the injection system.

17.8 Intake air temperature compensation

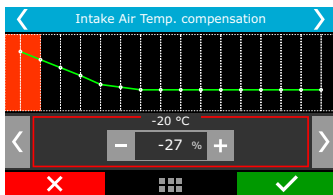
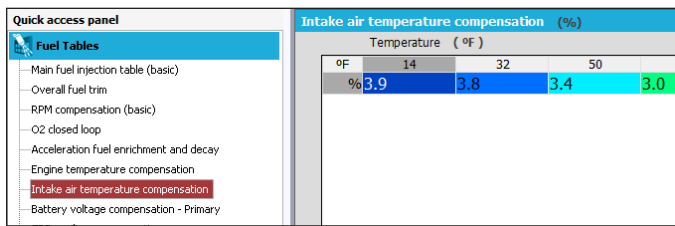

This compensation is applied based on the air temperature sensor placed in the intake manifold, and it is only available when the sensor is connected to the injection system.

This compensation mode is used to automatically adapt the injection to different temperatures of the air taken by the engine. In turbocharged engines, it is of great importance, because when the system is pressurized, the temperature rises immediately to very high numbers.

17.9 Battery voltage compensation

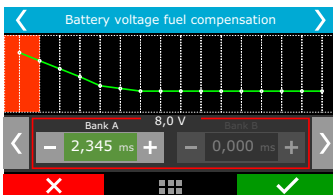
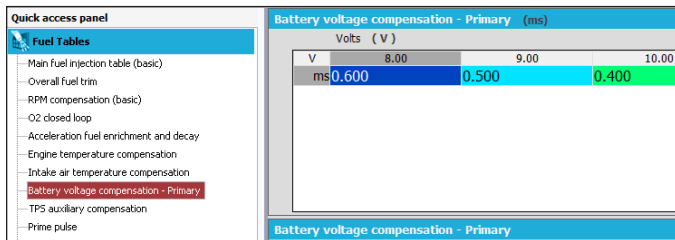

With lower battery voltages the injectors takes a longer time to open and to close. This table is used to compensate this variation.

Fuel injectors with a high flow rate usually operate with minimum injection time at idle speed and are the ones most affected by a battery voltage drop.

17.10 MAP / TPS compensation

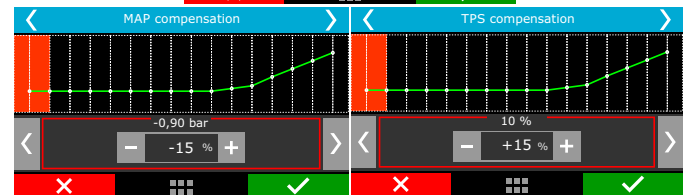
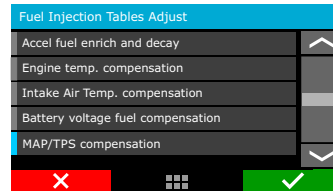
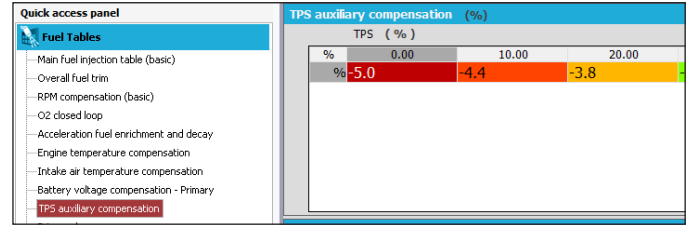

This table changes according to the main map configuration (MAP or TPS). When the main fuel table is setup by MAP, this table is a compensation by TPS. When the main fuel table is setup by TPS, this compensation is by MAP.

17.11 Prime pulse

This feature improves the engine start by injecting fuel when any crank trigger tooth is detected, just like OEM ECUs. Usually this table uses injection times higher than the "engine start" parameter injection times.

Select which fuel bank you want to use for prime pulse and setup its table by engine temperature.

The injection time is related to engine temperature. The colder the engine, the bigger the injection time.

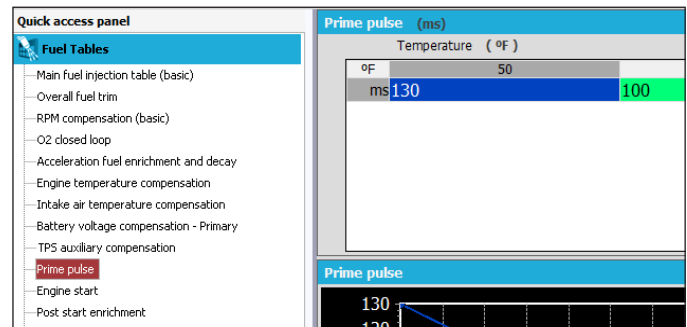

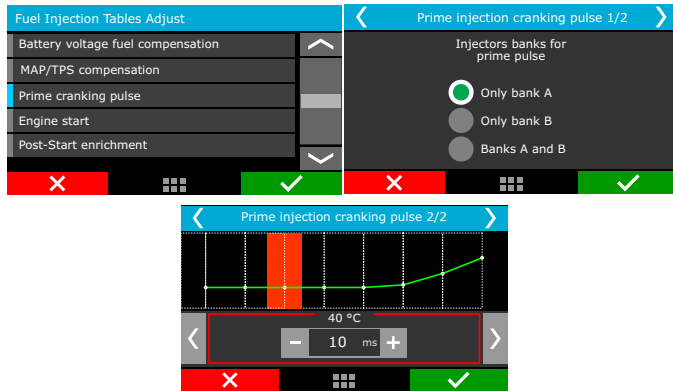

17.12 Engine start

This function is essential when starting the engine, as it needs a greater injection pulse to initiate its operation, especially if the vehicle runs on ethanol or methanol.

Whenever the RPM drops below 400rpm, the ECU applies start injection pulses in addition to the idle speed value. This excess of fuel prevents the engine from failing involuntarily, making it return to idle speed. Be careful not to exaggerate on injection time, as it may cause the engine to stall/flood easily.

The engine must always be turned off through the injection system. Otherwise, if RPM drops below 400rpm and injection is turned on, the system injects fuel that will not be burned and, therefore, will be accumulated on the cylinder.

If the engine temperature sensor has not been installed, only the value from start injection with cold engine is considered.

The bank B option will be only available if enabled on "Injection" menu on "Engine Settings"

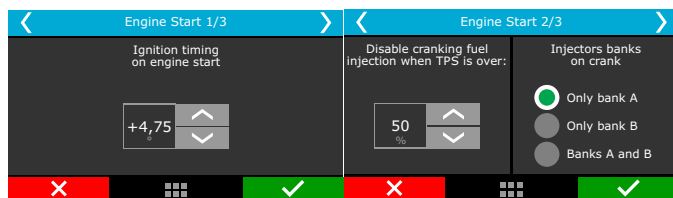
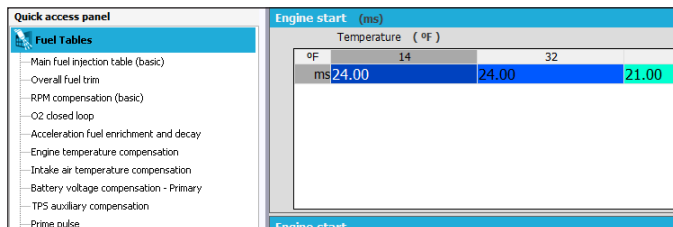

17.13 Post-start enrichment

This configuration is a table that relates engine temperature with time in seconds. This parameter helps stabilizing engine RPM just after start, improving the idle control especially under low temperature conditions.

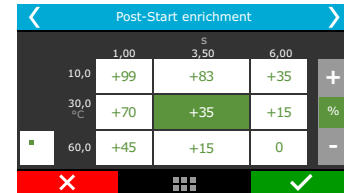
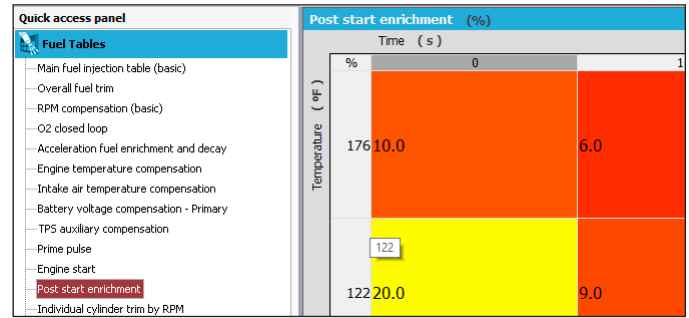

17.14 Individual cylinder trim

Set a compensation to each injectors output on a table that relates engine RPM with individual cylinder trim compensation.

To use this compensation as a cylinder trim, the injectors have to be wired with one output per injector.

This compensation usually brings expressive power gains when correctly used, so, the use of one O2 sensor per cylinder is highly recommended

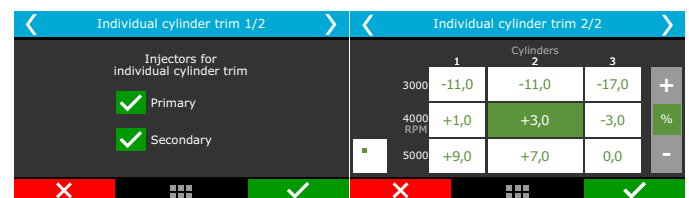
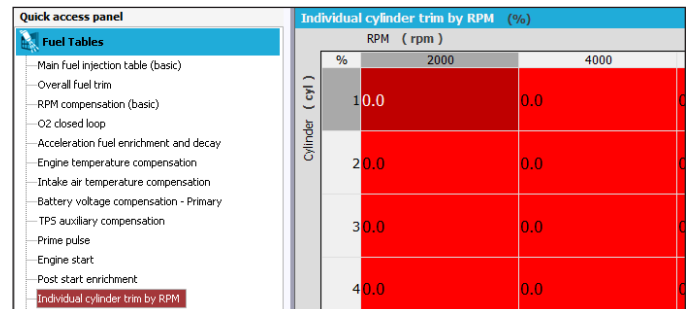

17.15 Rotor compensation

Available only when controlling rotary engines, this is an individual rotor fuel trim. This compensation usually brings expressive power gains when correctly used, so, the use of one O2 sensor per rotor is highly recommended.

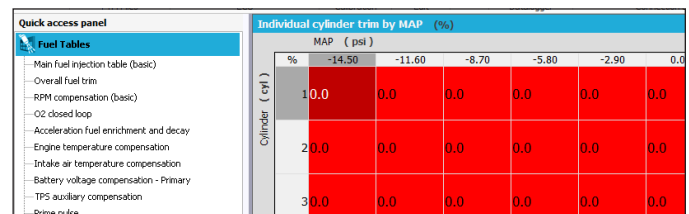

	1	2	3	
3000	-11,0	-11,0	-17,0	+
4000	+1,0	+3,0	-3,0	%
5000	+9,0	+7,0	0,0	-

17.16 Gear based compensation

This option allows having a RPM based fuel compensation for each gear.

To enable this option, gear change detection must be enabled. It is possible to set up to 6 compensation tables (6 gears).

Gear (gear)	Time (s)		
	0.00	0.20	0.4
1 -> 2	20,0	0,0	0,0
2 -> 3	30,0	0,0	0,0
3 -> 4	40,0	0,0	0,0
4 -> 5	50,0	0,0	0,0
5 -> 6	60,0	0,0	0,0

17.18 Fuel injection phase angle table

This table changes the moment, during the engine cycle, where the injectors opens or closes and is only available when the fuel injection is being controlled in sequential mode. The injection phase angle is the distance, in degrees BTDC from the ignition TDC (0°) until the moment the injector opens or closes (according to what is selected).

RPM (rpm)	1000	2000	3000	4000
*BTDC	352,8	355,4	360,1	400,0

17.17 Gear shift fuel enrichment

This function enables fuel compensation when a gear shift is detected, that allows building a time based enrichment table.

Gear (gear)	Time (s)		
	0.00	0.20	0.4
1 -> 2	20,0	0,0	0,0
2 -> 3	30,0	0,0	0,0
3 -> 4	40,0	0,0	0,0
4 -> 5	50,0	0,0	0,0
5 -> 6	60,0	0,0	0,0

Time [s]	1	2	3	4	5	
		0,00	0,05	0,10	0,20	1,00
Percent [%]	+0,0	+5,0	+4,5	+4,0	+0,0	%

18. Ignition tables adjust

All timing tables can advance or retard timing. When a base map is generated, all tables are filled with standard values, so, if you want to use just the main timing table, you must zero fill all compensations manually.

18.1 Main ignition table

The editing mode of this table is, by standard, the simplified 2D table, being possible to change it to advanced 3D table via FTManager software.

Through the software is also possible to edit the range interval of MAP, TPS and engine RPM on the maps. This makes possible to increase the detail level on specific ranges where a fine tuning is needed.

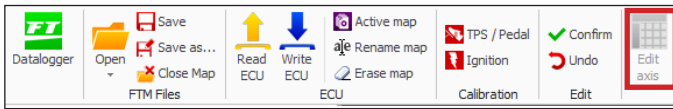

Basic mode 2D table

In this mode, the main ignition table is a 2D map that relates RPM and timing from 400rpm to the max RPM.

Using an analogy, if you want an initial timing of 15° and final of 32° (as you do on a distributor), you must enter 15° at 600rpm and 32° at the maximum rpm, 8600rpm for example. The timing between maximum and minimum RPM are interpolation of initial and final timing. If you want to run a fixed timing, all cells must be filled with the same timing.

Remember that the timing applied will only be the same as the main table if all the compensations are zero.

The rpm breakpoints can be changed up to 32 cells, allowing a fine tuning.

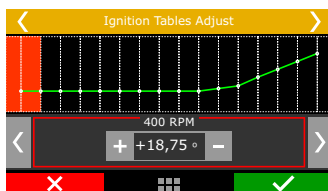
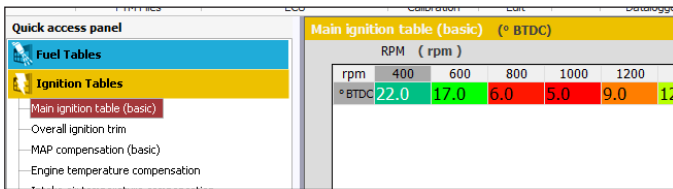

Advanced mode 3D table

In this mode, the main ignition table is a 3D map that relates RPM x MAP x ignition timing. As well as the basic mode, the MAP range is from -14.5psi up to de desired pressure. When the main timing table is by TPS, the table is from 0 to 100% in 10% steps.

The default RPM steps are 200rpm until 3000rpm, and above this rpm the steps are in 500rpm. The MAP, TPS or RPM steps can be edited via FTManager

RPM (rpm)	MAP (psi)						
	° BTDC -11.60	-10.15	-8.70	-7.25	-5.80	-4.35	-2.9
8000	44.0	41.6	40.4	39.1	38.2	37.6	37.3
7600	42.7	40.4	39.3	38.2	37.7	37.0	36.6
6800	40.1	38.2	37.2	36.2	36.8	35.8	35.4
6000	37.6	35.9	35.1	34.3	35.9	34.7	34.0
5200	37.2	36.3	35.8	35.4	35.0	33.5	32.8
4400	36.7	36.6	36.5	36.4	35.9	34.4	33.6
3600	36.3	36.9	37.2	37.5	36.8	35.2	34.4

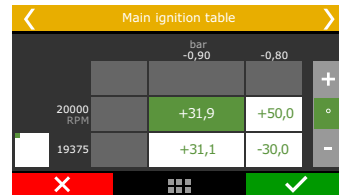

18.2 Overall ignition trim

To apply a quick compensation to the entire ignition map, the Overall Ignition Trim function may be used. It is only necessary to inform the correction, negative or positive, and confirm by pressing the right button. This correction will be added to or subtracted from the entire ignition table based on RPM

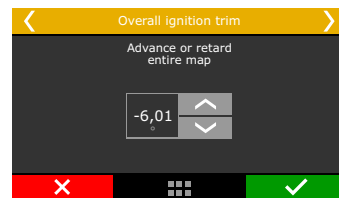
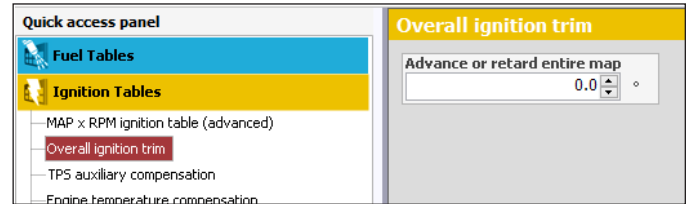

18.3 MAP/TPS compensation

This table changes according to the main map configuration (MAP or TPS). When the main ignition table is setup by MAP, this table is a compensation by TPS. When the main ignition table is setup by TPS, this compensation is by MAP.

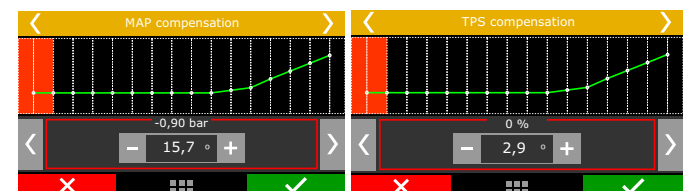
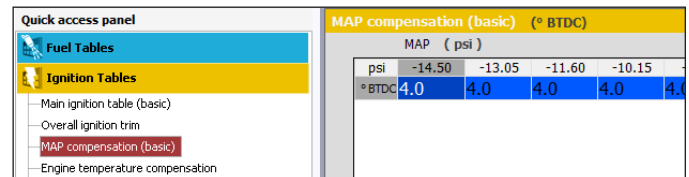

18.4 Engine temperature compensation

This map represents a compensation on the advance or retard angle applied to the main RPM map based on engine temperature variation. It is a very important feature and it brings significant improvement on drivability, especially while operating cold engines, when advanced ignition timing is necessary in order to have a correct response from the engine. It is also essential for engine protection, as it retards the ignition timing when the engine reaches high temperatures.

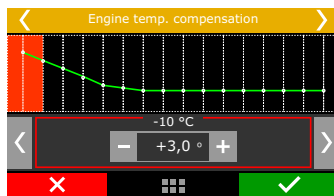
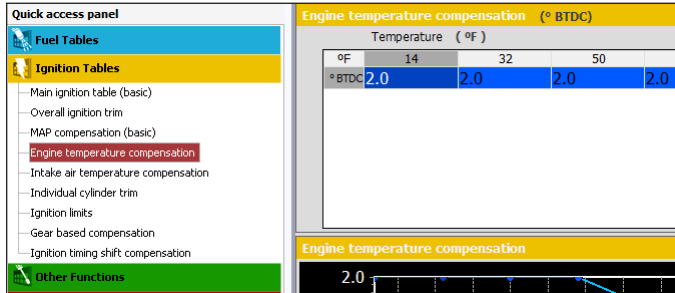

18.5 Intake air temperature compensation

This map represents a timing compensation applied to the main RPM timing map based on intake air temperature variation.

It is beneficial, because the colder the air entering the combustion chamber, the denser it is, and the greater the possible ignition advanced is.

But when temperatures are very high (especially on turbocharged engines), the ignition timing must be retarded to protect the engine.

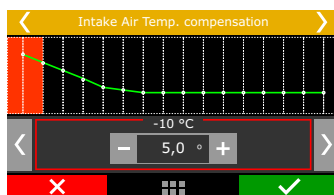
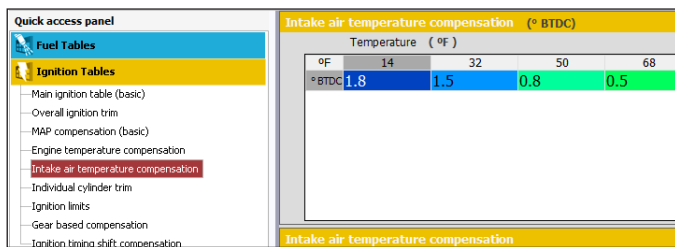

18.6 Rotary timing split

This menu is only shown when controlling Rotary engines. This is the timing split between Leading and Trailing spark plugs.

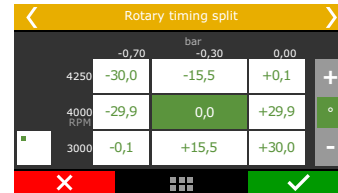
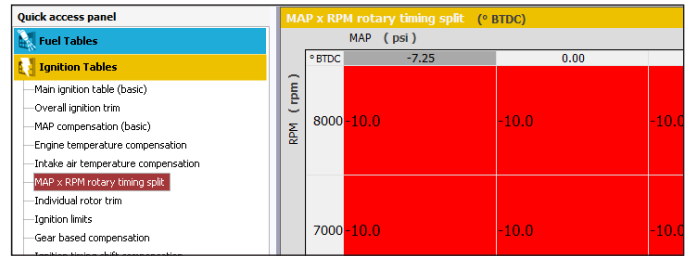

18.7 Individual cylinder trim

Set a timing compensation to each ignition output on a table that relates engine RPM with individual cylinder trim compensation. The timing compensation is done individually to each cylinder according to the engine RPM and it comes from the flow differences, heating dissipation capacity or even cylinder position.

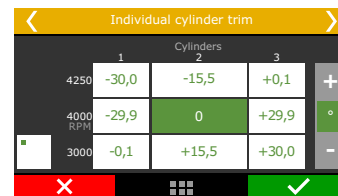
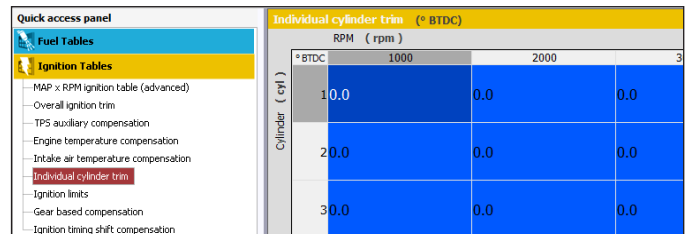

18.8 Rotor compensation

Available only when controlling Rotary engines, this is an individual rotor ignition trim.

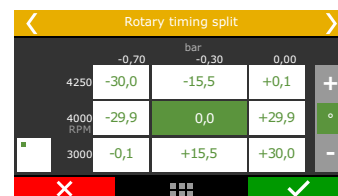
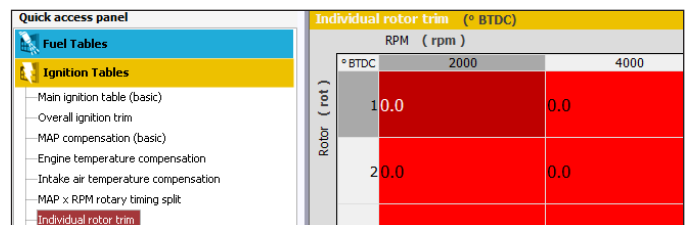

18.9 Timing limits

Configure in this menu the maximum and minimum ignition timing limits, so the engine won't run in any situation with too much retard or advanced ignition timing. No other function will be able to apply timing beyond these limits. This is a safety feature to prevent an inappropriate timing, considering all the functions that may enable a timing compensation (mainly drag race time based features).

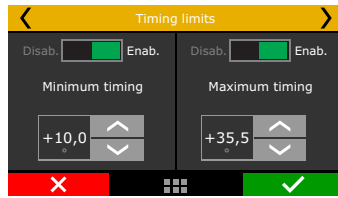
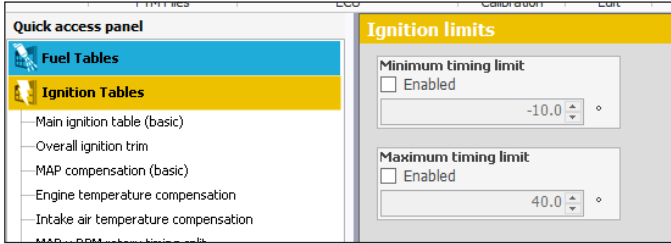

18.10 Engine Start

This is an ignition advance vs engine temperature table. Calibrate the ignition advance for each temperature site.

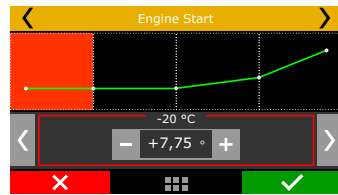
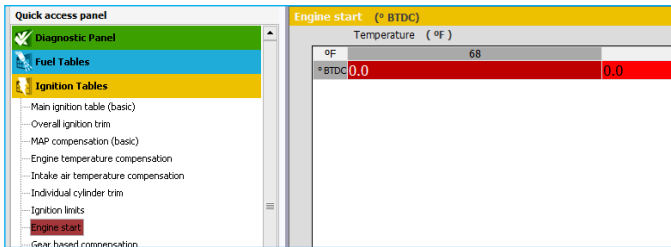

18.11 Gear compensation

This compensation allows advancing or retarding the ignition timing according to the engaged gear. This table applies the compensation in the main ignition table according to engaged gear and RPM.

To enable this option, gear change detection must be enabled. It is possible to set up to 6 compensation tables (6 gears).

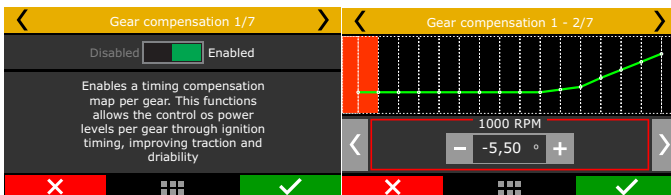

Quick access panel		Gear based compensation (° BTDC)	
Fuel Tables		RPM (rpm)	
Ignition Tables		1000	2000
Gear (gear)	1.0.0	1000	0.0
	2.0.0	1000	0.0
	3.0.0	1000	0.0
	4.0.0	1000	0.0

18.12 Gear shift compensation

This function allows advancing or retarding the timing after a gear shift (upshift).

You can enable a TPS condition so the retard can happen.

In the example, there will be a 5° timing retard. The ramp return time is the retard total time, which will be gradually re-established. In other words, after shift gear, timing will be retarded 5°, 0,25s the retard will be 2.5° and 0,50s after the shift there will be no gear shift compensation.

To enable this option, gear change detection must be enabled. It is possible to set up to 5 compensation tables (6 gears).

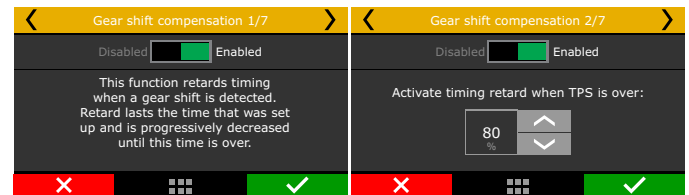
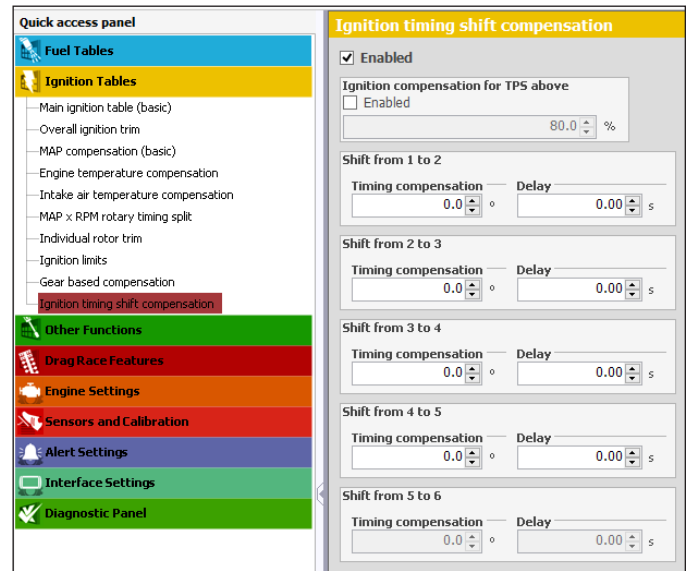

18.13 Gear shift compensation

This function retards the ignition timing as soon as the gear shift is detected. The delay time lasts as long as it's configure, and is progressively decreased until it reaches the end.



NOTE:

To use this function it's necessary to have gear detection activated.

Quick access panel

- Diagnostic Panel
- Fuel Tables
- Ignition Tables**
 - Main ignition table (basic)
 - Overall ignition trim
 - MAP compensation (basic)
 - Engine temperature compensation
 - Intake air temperature compensation
 - Individual cylinder trim
 - Ignition limits
 - Engine start
 - Gear based compensation
 - Ignition timing shift compensation**
- Other Functions
 - Internal datalogger
 - Individual channel options
 - Individual digital channel options
 - Idle speed control
 - Deceleration cutoff
 - Rev limiter
 - Shift light

Ignition timing shift compensation

Ignition compensation for TPS above
 Enabled 80.0 %

Shift from 1 to 2
 Timing compensation: 0.0 ° Return ramp: 0.00 s

Shift from 2 to 3
 Timing compensation: 0.0 ° Return ramp: 0.00 s

Shift from 3 to 4
 Timing compensation: 0.0 ° Return ramp: 0.00 s

Shift from 4 to 5
 Timing compensation: 0.0 ° Return ramp: 0.00 s

Shift from 5 to 6
 Timing compensation: 0.0 ° Return ramp: 0.00 s

Gear shift based comp. 2/7
 Disabled Enabled
 Apply compensation with TPS above: 80 %

Gear shift based comp. 3/7
 Timing ramp for gear shift 1 - 2
 Timing compensation: -5.00 ° Ramp return time: 0.50 s

19. Other functions

This menu allows the adjustment of all functions that modify the operation of auxiliary outputs and compensations of idle speed, etc.

19.1 Internal datalogger

This function is used to log all the engine data read by FuelTech ECU.

The Internal Datalogger can record up to 256 channels like: injection time (banks A and B), injectors duty cycle (banks A and B), timing, engine rpm, auxiliary output status, TPS, coolant and air temperature, oil and fuel pressure, O2 sensor, two-step button, MAP sensor, camshaft position sensor and battery voltage.

Log download and data analysis are done through the computer and FTManager Software.

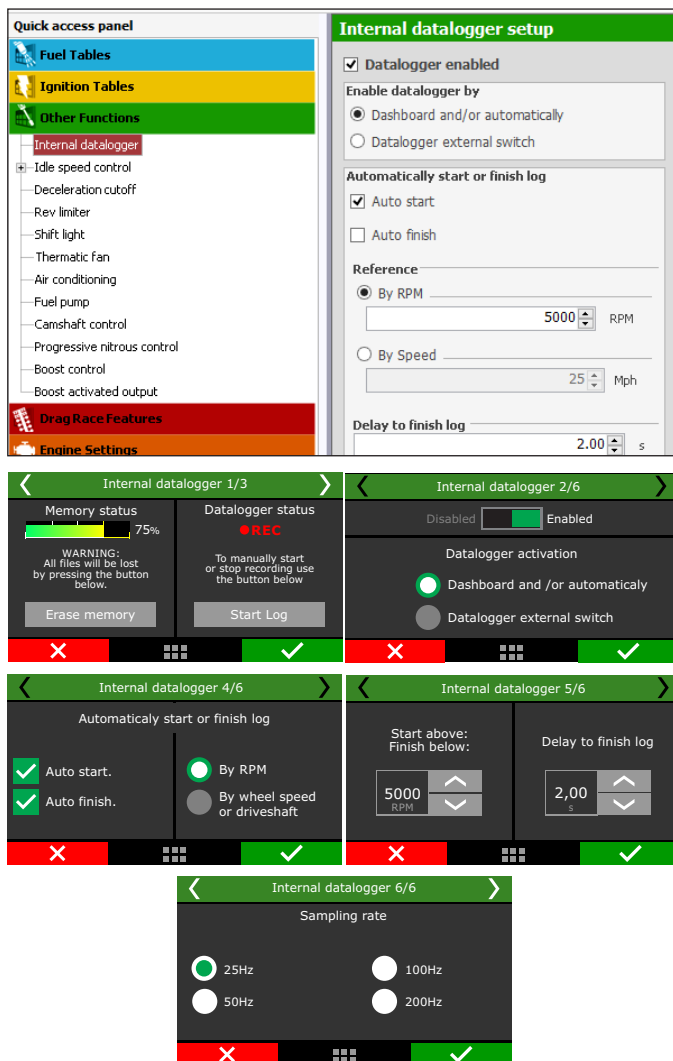

Datalogger enabled

Select if the datalogger is enabled or not and set the start/finish mode.

Through dashboard a touchscreen button will start or stop the recording. Through external switch an white input must be wired to an on/off switch to enable the recording. While the input is grounded the datalogger will be recording.

It is possible to choose two modes for the Internal Datalogger:

Basic: All channels are logged with the same sampling rate.

Advanced: allows the user to select the channels that will be logged and their sampling rate. Functions and sensors added after setting the internal datalogger on advanced mode will be automatically logged with the default sampling rate, but this can be changed if desired.

Log start and stop

The internal datalogger start and stop trigger can be set up by RPM signal or by a button on the ECU dashboard.

When selecting “RPM Signal”, the log will be started only when the programmed RPM is reached. If a button on the dashboard is preferred, select it on the internal datalogger. After that, go to “Interface settings” menu and set up the datalogger button on a spot under “Dashboard setup.”

Log is automatically stopped when memory is full, ECU is turned off or the button is pressed.

Via FTManager software, the log can be started or finished through the “Start log” and “Stop log” in the tool bar. The “Erase memory” will clear all the logs in the FT600 memory.

Sampling rate

The sample rate defines log quality. Higher the sample rates created more detailed logs, however, the logging time available will be shortened. For competition vehicles, especially drag racing, it is recommended to use a high sample rate to have high detail level on the log.

The **lower** the sample rate, the more “square” will be the graph and less detailed. On the other, the **higher the sample rate**, the more detailed the log.

Individual channel options

In this menu it is possible to setup each channel individually about line color, if it will be visible or not, its scale and, when in the advanced mode, its sampling rate.

Record	Color	Channel	Sample rate	Visible	Fixed scale
<input type="checkbox"/>		Pressure1 (FuelRun_DigitalChannel1)	500	<input type="checkbox"/>	<input type="checkbox"/>
<input type="checkbox"/>		Pressure1 (FuelRun_DigitalChannel2)	500	<input type="checkbox"/>	<input type="checkbox"/>
<input type="checkbox"/>		Pressure1 (FuelRun_DigitalChannel3)	500	<input type="checkbox"/>	<input type="checkbox"/>
<input type="checkbox"/>		Pressure1 (FuelRun_DigitalChannel4)	500	<input type="checkbox"/>	<input type="checkbox"/>
<input type="checkbox"/>		Pressure1 (FuelRun_DigitalChannel5)	500	<input type="checkbox"/>	<input type="checkbox"/>
<input type="checkbox"/>		Pressure1 (FuelRun_DigitalChannel6)	500	<input type="checkbox"/>	<input type="checkbox"/>
<input type="checkbox"/>		Pressure1 (FuelRun_DigitalChannel7)	500	<input type="checkbox"/>	<input type="checkbox"/>
<input type="checkbox"/>		Pressure1 (FuelRun_DigitalChannel8)	500	<input type="checkbox"/>	<input type="checkbox"/>
<input type="checkbox"/>		Pressure1 (FuelRun_DigitalChannel9)	500	<input type="checkbox"/>	<input type="checkbox"/>
<input type="checkbox"/>		Pressure1 (FuelRun_DigitalChannel10)	500	<input type="checkbox"/>	<input type="checkbox"/>
<input type="checkbox"/>		Pressure1 (FuelRun_DigitalChannel11)	500	<input type="checkbox"/>	<input type="checkbox"/>
<input type="checkbox"/>		Pressure1 (FuelRun_DigitalChannel12)	500	<input type="checkbox"/>	<input type="checkbox"/>
<input type="checkbox"/>		Pressure1 (FuelRun_DigitalChannel13)	500	<input type="checkbox"/>	<input type="checkbox"/>
<input type="checkbox"/>		Pressure1 (FuelRun_DigitalChannel14)	500	<input type="checkbox"/>	<input type="checkbox"/>
<input type="checkbox"/>		Pressure1 (FuelRun_DigitalChannel15)	500	<input type="checkbox"/>	<input type="checkbox"/>
<input type="checkbox"/>		Pressure1 (FuelRun_DigitalChannel16)	500	<input type="checkbox"/>	<input type="checkbox"/>
<input type="checkbox"/>		Pressure1 (FuelRun_DigitalChannel17)	500	<input type="checkbox"/>	<input type="checkbox"/>
<input type="checkbox"/>		Pressure1 (FuelRun_DigitalChannel18)	500	<input type="checkbox"/>	<input type="checkbox"/>
<input type="checkbox"/>		Pressure1 (FuelRun_DigitalChannel19)	500	<input type="checkbox"/>	<input type="checkbox"/>
<input type="checkbox"/>		Pressure1 (FuelRun_DigitalChannel20)	500	<input type="checkbox"/>	<input type="checkbox"/>

Internal datalogger status

At the Dashboard Screen of the ECU, a round icon is shown besides engine RPM. This icon indicates the Internal Datalogger status.

- Internal datalogger **stopped**: grey “Data” button
- **Recording**: green “Data” button, blinking light **red** icon with the word **REC**
- **Memory full**: red “Data” button with the word **FULL**

NOTE: when memory is full, connect the ECU to the PC and download the data through FTManager Software.

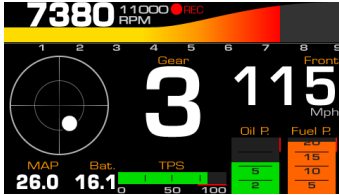

Log download

The log download must be through FTManager. Connect the FT600 to the computer with the USB cable



Open the FTManager, and click on the Datalogger icon. The FTManager Datalogger will open. To download, click on the Download icon and a window will pop up showing all logs saved on the ECU. Select the files and click ok.

The will open. Use the mouse to browse the graph and check the values on the left panel.

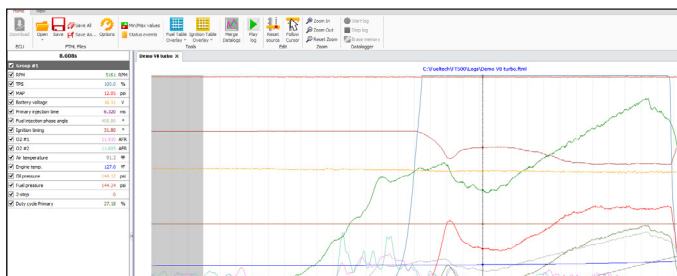
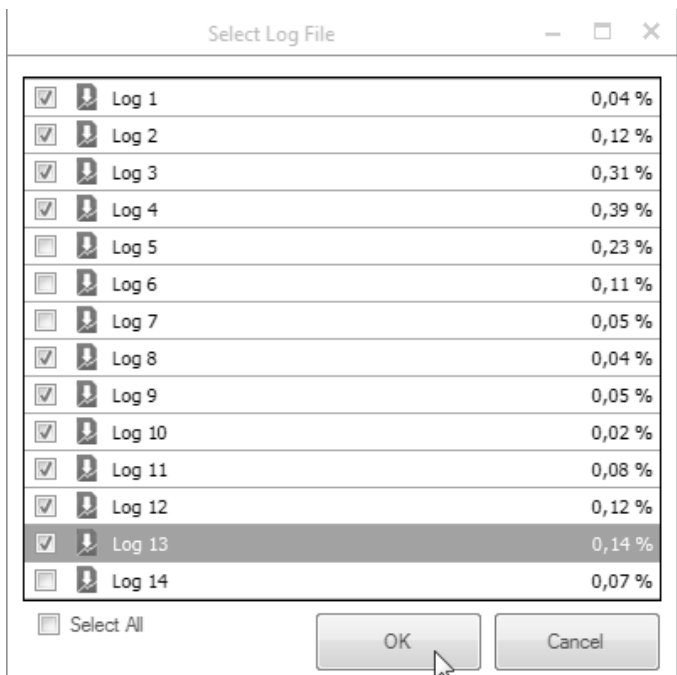
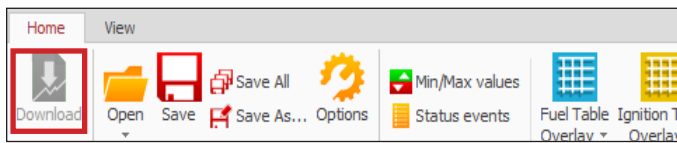

19.2 Accelerometer and gyroscope

FT600 has an internal 9-axis accelerometer which provides the following data:



NOTE:

See section 15:19 for the accelerometer calibration.



ATTENTION:

In order for the accelerometer and gyroscope to work properly and have correct readings, a calibration of the sensor is required. The FT600 should be installed as vertical as possible, with a maximum inclination of 45°. The connectors must face the front of the vehicle. The screen must face the rear of the vehicle.

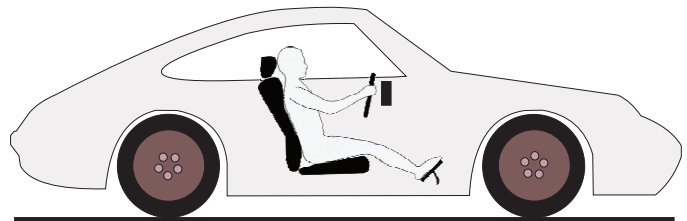

G-Force acceleration: records the vehicle's acceleration force.

G-Force braking: records the vehicle's braking force.

Pitch angle: records the vehicle's pitch angle.

Pitch rate: records the vehicle's pitch rate.

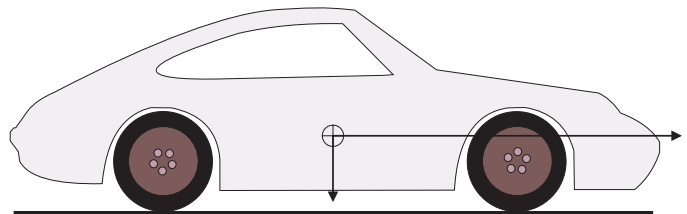
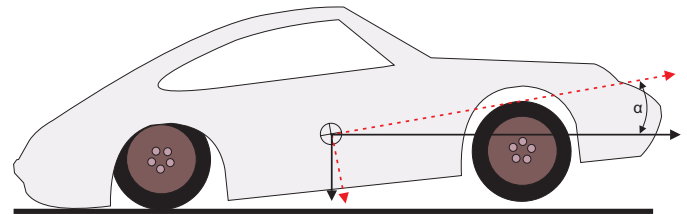

Lateral G-Force: registers the vehicle's lateral force.

Roll: registers the vehicle's roll angle.

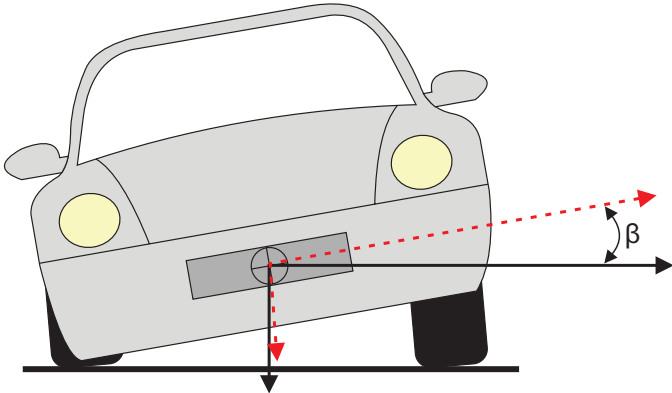

Speed under acceleration: calculates the speed based on the vehicle's acceleration.

Distance under acceleration: measures the traveled distance based on the vehicle's acceleration.

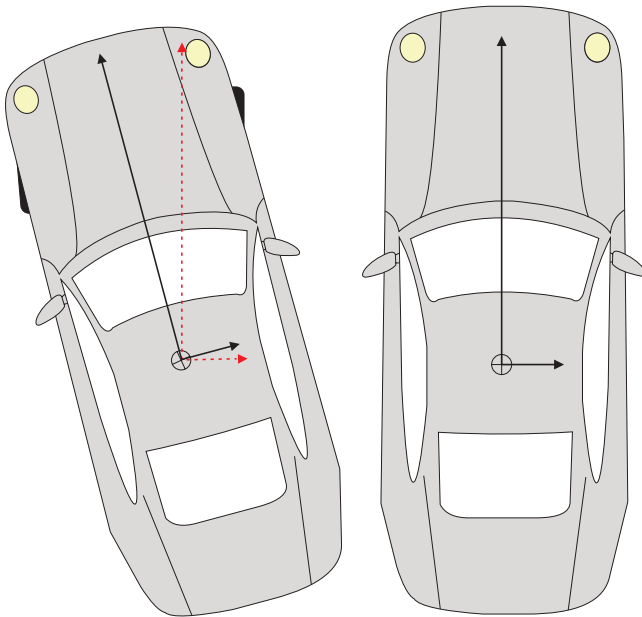

Direction: records the calculated position in degrees based on the moment the vehicle launched.



NOTE:

The features: speed under acceleration, distance under acceleration, roll angle and pitch angle are calculated only after a valid launch (when with the 2-step activated the engine hits TPS higher than 50% or the 2-step rev limiter).

19.3 Idle speed control

This FT600 can control idle speed through electronic throttle, step motor, PWM valve and by timing.

To enable the idle speed control by electronic throttle, it is needed to setup the menu "Electronic throttle" under "Engine setup" menu. After that, you can follow this menu to setup idle parameters.

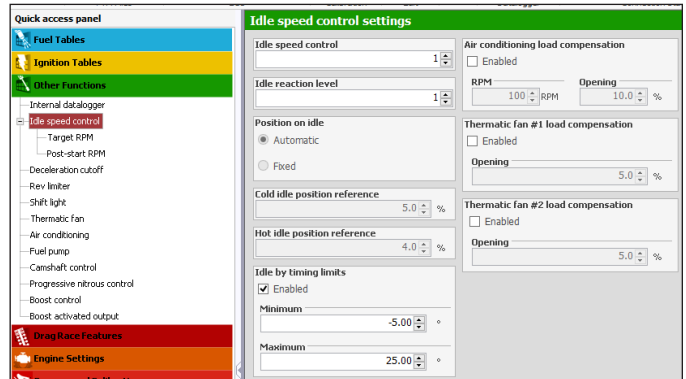
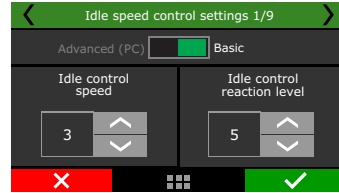

Actuator reaction level: this parameter is the aggressiveness that the timing and the actuator will be changed of position in order to control a RPM fall. The higher this number, the more aggressive is the reaction of the control.

High reaction levels may lead the idle speed to be unstable.

Position on idle

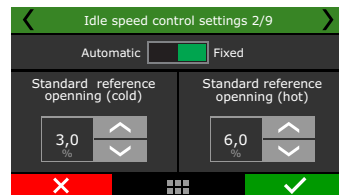

Automatic: in this mode, idle actuator is automatically opened and closed by the ECU in order to make the engine idle near the target RPM.

Fixed: in this option, idle actuator assumes a fixed position, set up later according to engine temperature.

ETC reference position: this parameter is the actuator position when the engine is turned off or cranking. It is also used as a stable reference during the automatic idle speed control. Setup a value that's enough for a cold start of the engine. Start with a value around 4% for electronic throttle and 30% for step motor.

Idle speed by timing

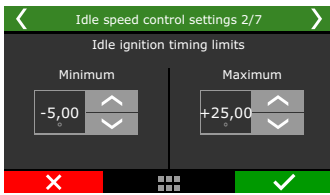

This control uses a target RPM for idle speed and works advancing and retarding the engine timing to keep the engine running near the specified RPM.

As the FT600 idle speed control has an advanced integration with the idle speed by timing control, this one stays always enabled when any other kind of idle speed control is selected. By doing this, the idle speed actuator is always kept in a position where the idle speed by timing control can set the timing away from the maximum and minimum timing positions.

Maximum and minimum timing limits: these values are the limits for advance and retard when ECU is controlling the idle by timing.

Actuator position

This parameter will be only available when the position on idle is set as fixed. This table relates the actuator position in function of the engine temperature.

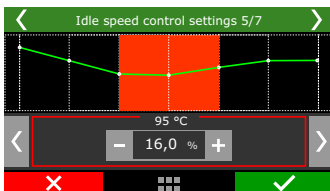
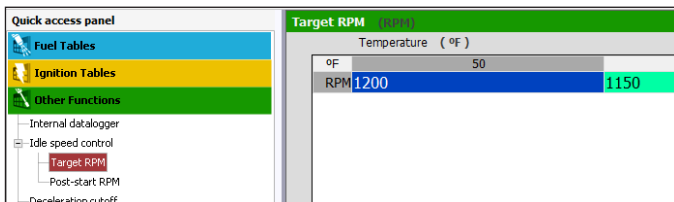

Post-start position

This parameter will be only available when the position on idle is set as fixed. The table controls the actuator opening after the engine start. The table is an actuator position vs time. After the time slip, the position is defined by the actuator position table based on engine temperature.

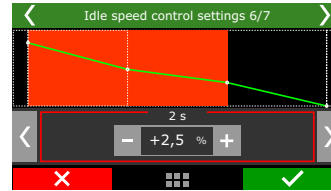
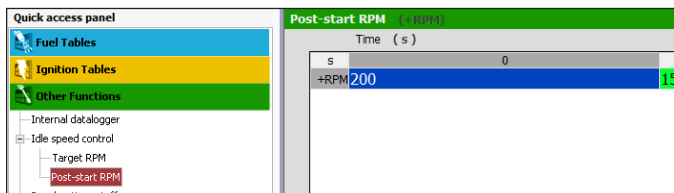

RPM for idle speed

This table tells the ECU the target RPM the idle control will assume, according to engine temperature. On intermediate temperature ranges, target RPM is automatically interpolated.

When "Position on idle" is set to "fixed" this table represents the actuator position X engine temperature.

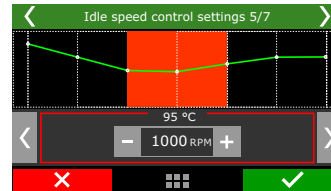
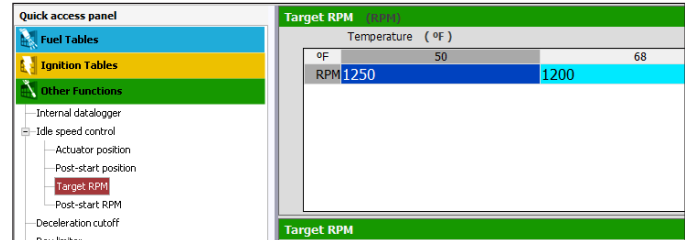

Post-Start position

This parameter is a RPM increase (or % of increase in the actuator position for fixed idle position). The table shows the actuator position according to time post engine start.

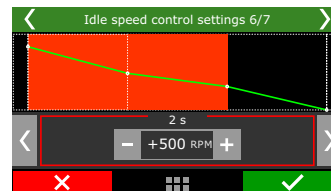
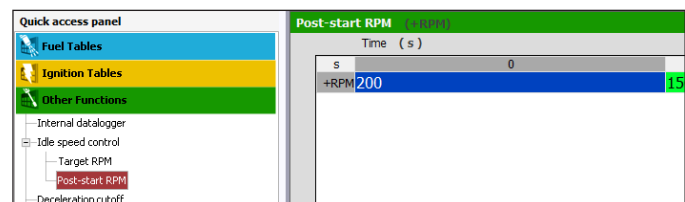

Compensation by load: used to compensate actuator position when suddenly loads (like AC or fan) are added to engine and can affect idle. It is possible to set an target RPM compensation when the AC is on and fuel/actuator opening compensation for AC and fans.

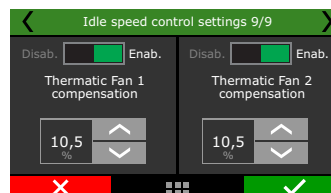

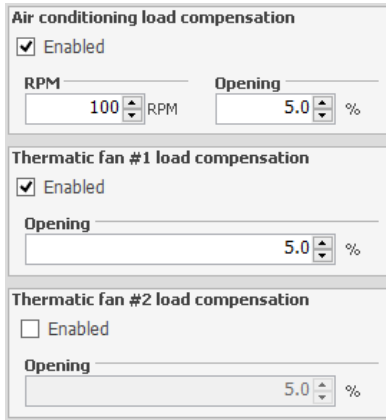

19.4 Deceleration cut-off

This function cuts-off fuel every time the throttle is not being pressed and the engine is above the chosen RPM.

It results in a great gain of economy, because fuel is not wasted when the car is let run with gears engaged, when engine brake is begin used, or when the driver steps off the gas to make turns or in regular transit situations.

When situations like the ones mentioned above are considered altogether, the deceleration fuel cut-off provides a valuable reduction of fuel consumption after all.

Another benefit in using this function is keeping the engine of a circuit car “dry on fuel” when coming out of turns.

When a circuit car has its breaks actuated in order to make a turn, it is necessary that it has a quick and clean response from the engine as soon as it starts picking up speed again at the end of turn.

In long races, the economy is another very important factor.

A standard RPM of 2000rpm is recommended. Setting a very low RPM may cause the engine to turn off involuntarily during deceleration. The “Cut-off Delay for TPS=0%” parameter is the time (in seconds) delay before fuel is actually cut-off after releasing the throttle. Such delay exists to avoid the engine to instantly become lean when the throttle is released. It also rapidly cools the combustion chamber without being excessive, and avoids situations in which the cut-off might oscillate, especially when the throttle is lightly pressed. A standard delay of 0.5s is suggested.

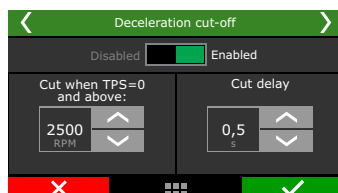
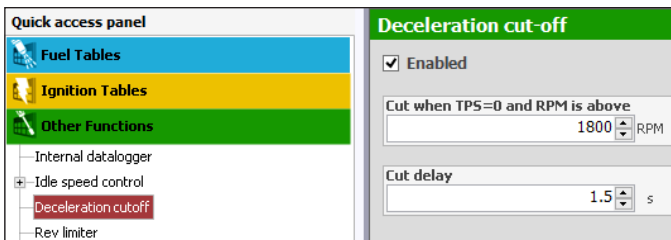

19.5 Revolution limiter

This function is very important for engine protection, limiting the RPM with two different options of cut-off:

Fuel Injection: the fuel injection is cut-off instantly, as the ignition is still operating. It is a very smooth and clean cut-off. Recommended only for naturally aspirated engines, it is the standard setting in vehicles with original injection systems.

Ignition: the engine ignition is cut-off when the configured RPM is reached. It is recommended for high-power engines, especially turbocharged ones, being the most efficient and safe option.

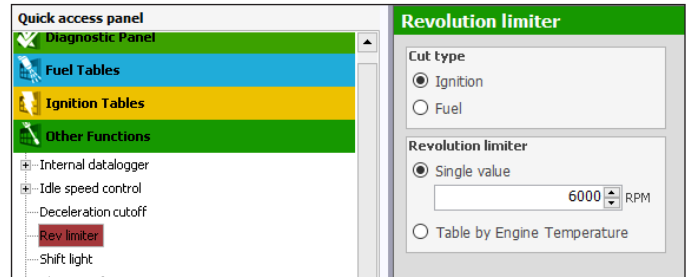

Rev limiter by engine temperature

When the option “table by engine temperature” is selected, it’s possible to set different rev limiters according to engine temperature

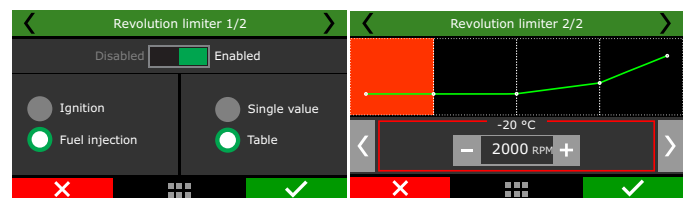
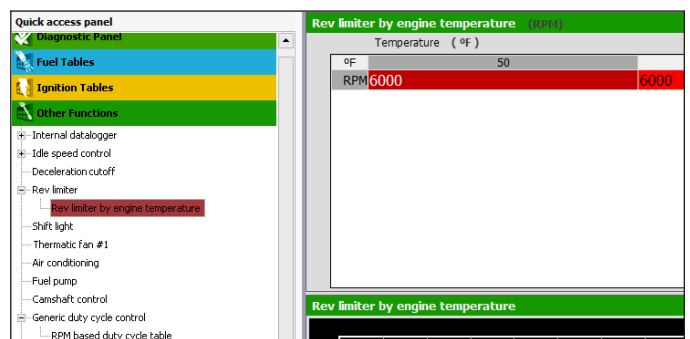

19.6 Shift Light

When the engine reaches the RPM set in this parameter, the screen will display a blinking message ("SHIFT") indicating that gear must be shifted.

To switch an external shift light, it is necessary to configure an auxiliary output at the "Input and Output Setup" menu. If no auxiliary output has been configured as Shift Light, the message "Output not configured!" will be displayed. Even so, it is possible to set the Shift Light RPM on the screen

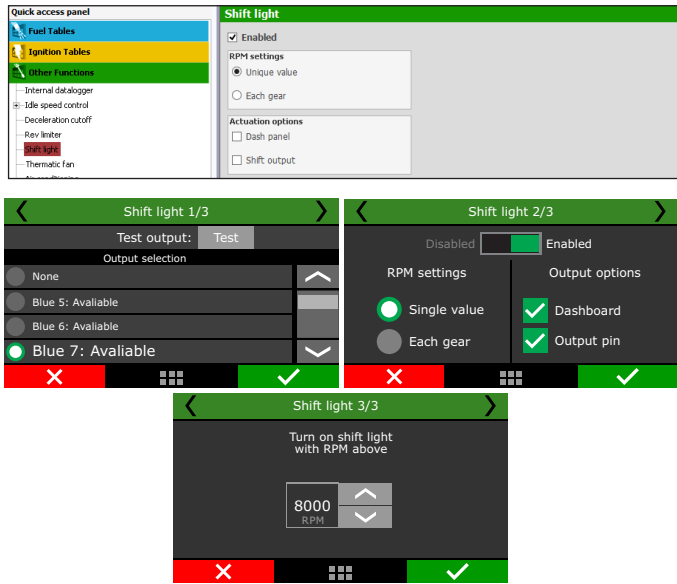

19.7 Electric fans 1 and 2

This FT600 can control up to two cooling fans on different temperatures. There's an option that allows one of the fans to be activated when A/C is turned on. As these fans may draw considerable load, a fuel compensation is also available.

To test the fan output, just click on the "Test output" button. If it doesn't work, check the install or test another output.

Through FTManager, the output configuration is done in the "Sensors and calibration" menu - Outputs.

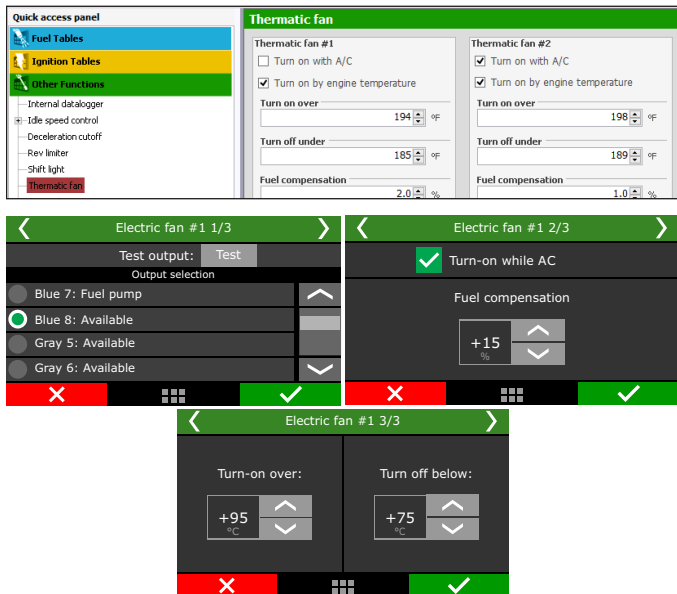

19.8 Air conditioning

To control air conditioning through FT600, first you have to setup an output to control the A/C relay. Then, setup the input that will receive signal from the A/C button on the car dashboard. Check chapter 13 for more information.

The turn on delay will happen in 3 different situations:

- When starting the engine with the AC button turned on, the turn on delay will start to count after the RPM for engine start is overcome. In this case, the reference is engine start, not the moment when the AC button is switched on.
- When turning off and then turning on the AC button, the turn on delay will count from the moment the AC button is turned off. If the time between turning off and then turning on is bigger the turn on delay set, the AC will be immediately activated.
- When the engine RPM is below the minimum RPM the turn off is immediate. The delay will count from the moment the RPM is below the minimum RPM. To turn on again, the delay will start to count when the engine RPM is 50RPM higher then the minimum.



19.9 Fuel pump

This output activates the fuel pump relay through lowside (0V) or highside (12V).

You can choose from the following options:

Always enabled (the output is permanently activated while the ignition switch is on)

Timed (when the ignition switch is turned on, the output is activated for a defined activation time, afterwards the output is deactivated. When engine speed signal is received, the ECU reactivates the output.).

During start (when the output is activated while it's below the starting engine speed).

It's required to use a relay that supports the necessary current for the fuel pump. Through the FTManager software, the output configuration is done through the menu "Sensors and calibration" and then "Outputs"

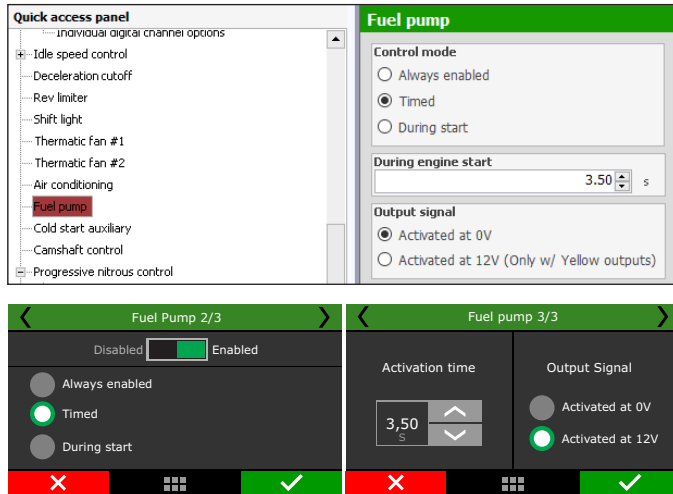

19.10 Cold start auxiliary

This feature is very useful for cold starts on methanol and alcohol engines using a gasoline injection auxiliary kit. The table shows the auxiliary injector time versus temperatures

The ECU will activate the output according to the time set on the table once it detects the first tooth from engine RPM on every engine start. The cold start auxiliary is disabled when cranking the engine with the accelerator pressed with TPS above the value set in the parameter "Disable injection on engine start with TPS above" in the "Injection" menu, under "Engine settings".

Output signal: Activation through 0V in the blue or gray outputs. The yellow outputs have the possibility to activate the outputs through 12V.
Time versus temperature curve: This table is composed of a pulse in seconds of the cold start injector depending on engine temperature.

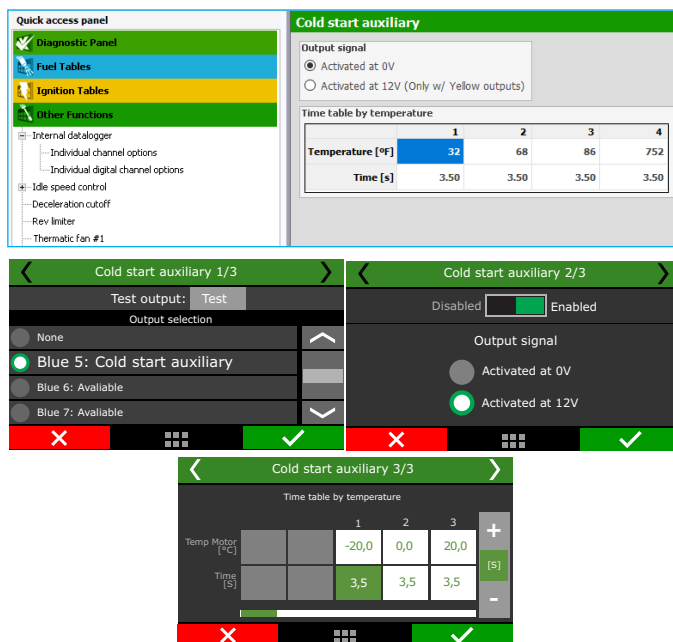

19.11 Camshaft control

This function allows the control of a variable valve timing control system (or a drag racing 2-gear automatic system). Select the output used to control the camshaft solenoid, and then, inform the RPM that the solenoid must be turned on. Only on/off camshaft systems can be controlled.

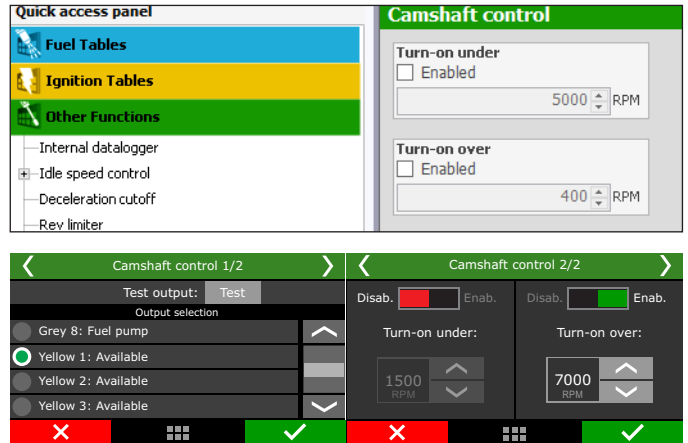

19.12 Progressive nitrous control

This auxiliary output configuration gives access to setting the ratio for the fuel-nitrous mixture (or nitrous only) through pulse-width modulation (PWM) sent to the solenoids.

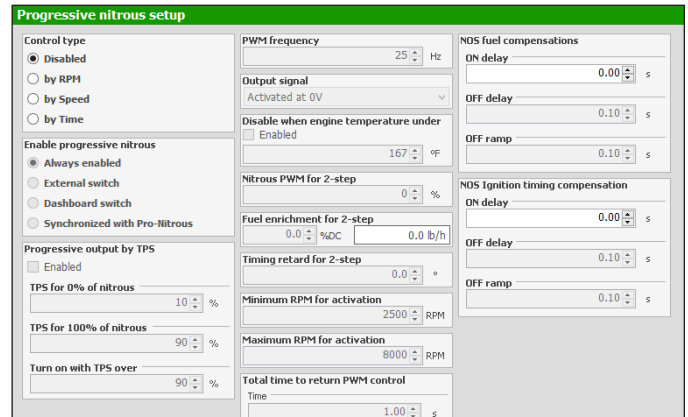

Select an auxiliary output as "Progressive nitrous output" and how the control will be performed: by time (after 2-step), by rpm or by wheel speed.

Also, select the enable mode:

- **Always enabled;**
- **External switch:** select a white input. When the input is grounded the progressive nitrous will be enabled;
- **Dashboard switch:** a touchscreen button must be configured to enable or disabled the progressive nitrous;
- **Synchronized with Pro-Nitrous:** the progressive nitrous control will activate when the Pro-Nitrous (Drag race features menu) conditions are met;

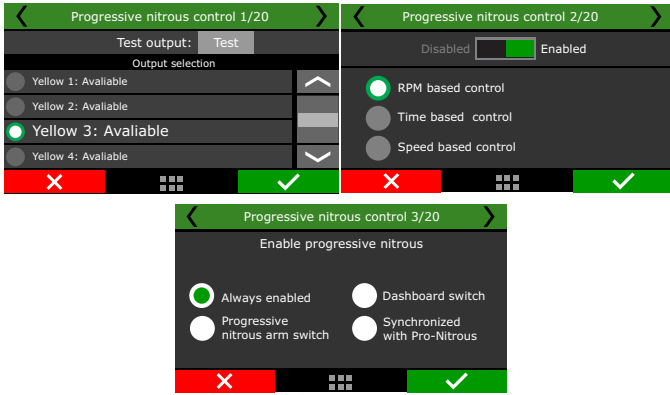

Next is the nitrous injection map based on RPM. The higher the percentage configured in this map, the higher the amount of nitrous (or nitrous + fuel) injected

The maximum RPM is the same chosen on "Fuel Injection Setup." With the FTManager you can edit axis and add or remove cells. When using 2 injector banks the fuel enrichment will happen on both.

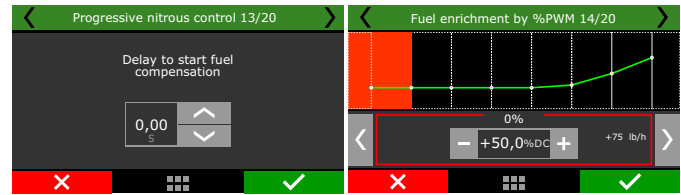

The first parameter to be configured is the TPS opening percentage, above which the injection of nitrous will be activated.

The next parameter is the percentage of fuel enrichment for 100% nitrous.

After this, set the PWM output frequency and the output signal. To regular solenoids, use between 25 and 30Hz, big shot solenoids use 50Hz. The next screen will show the engine temp protection, where you can define a minimum engine temperature for progressive nitrous.

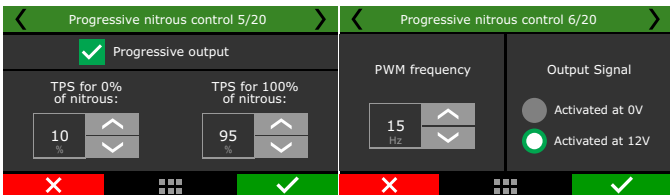

The ON delay for NOS fuel compensation avoids the extra fuel to get earlier than the NOS in the cylinder, very common when the fogger is far from the injectors.

The Progressive fuel table by nitrous duty cycle and the Auxiliary fuel enrichment table compensation are related to the percentage of fuel added according to %DC of nitrous or engine load/rpm.

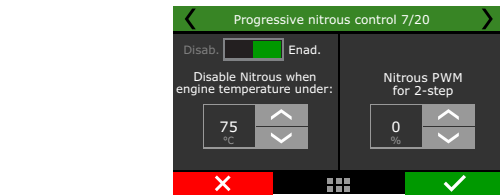

Shift light				
Thermatic fan				
Air conditioning				
Fuel pump				
Camshaft control				
Progressive nitrous control				
RPM based nitrous duty cycle table	11000	0.0	0.0	0.0
Progressive fuel table by nitrous duty cycle	9000	0.0	0.0	0.0
Auxiliary Fuel enrichment table compensation				
Progressive timing table by nitrous duty cycle				

The fuel enrichment for 2-step is a fuel compensation when the 2-step is enabled. The timing retard for 2-step is a compensation applied to the timing configured in the 2-step function. The minimum and maximum RPM is a RPM window and work as a safety feature, so the progressive nitrous will only active if the engine rpm is inside the window. The total time to return PWM control is a delay ramp to reactivate the progressive nitrous when it is disabled by any safety features or switch. This ramp avoids the progressive nitrous to return in a big shot, helping the traction on pedaling.

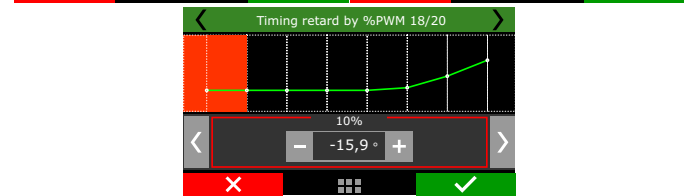
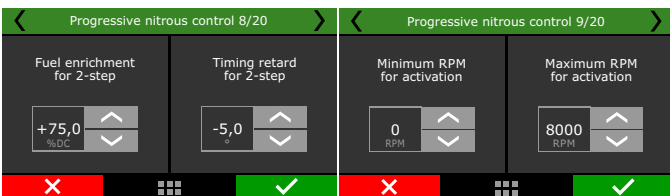
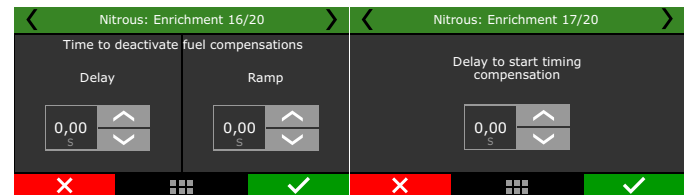

Quick access panel

- Fuel Tables
- Ignition Tables
- Other Functions
 - Internal datalogger
 - Idle speed control
 - Deceleration cutoff
 - Rev limiter
 - Shift light
 - Thermatic fan
 - Air conditioning
 - Fuel pump
 - Camshaft control

Auxiliary Timing retard compensation

rpm	500	700
°BTDC	0.0	0.0

Auxiliary Timing retard compensation

After the end of nitrous shot, normally is necessary to keep the compensations on for a few tenths of seconds, since the intake is full of nitrous that will be consumed by the engine. The OFF ramp makes the compensation ends smoothly.

The delay to start the timing compensation has the same purpose of fuel compensation, the time nitrous takes to reach the cylinder.

The Progressive timing table by nitrous duty cycle and Auxiliary timing retard compensation are related to the timing retard (always negative values) according to the %DC of nitrous and engine load/rpm.

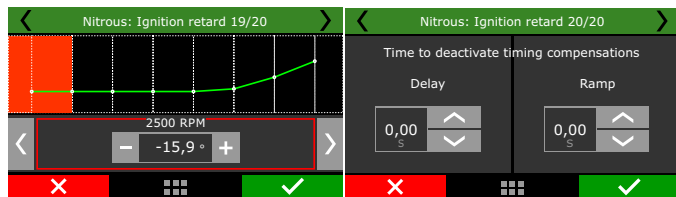
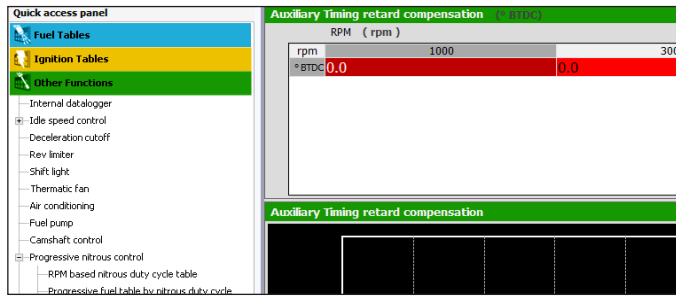

In the end, there are the OFF delay and the OFF ramp and are used to keep the engine safe, avoiding an immediate timing advance that could damage the engine.

19.13 Generic duty cycle output

This feature allows the control, through PWM, of a solenoid valve that manages the wastegate valve, therefore regulating the boost pressure. Through an external button, you can activate the Boost+ function (optional use), which is an instant increase in the boost %DC while the Burton is turned on.

FuelTech recommends using a 3-way button N75 solenoid.

For more information about its installation, see chapter 13.8 in this manual.

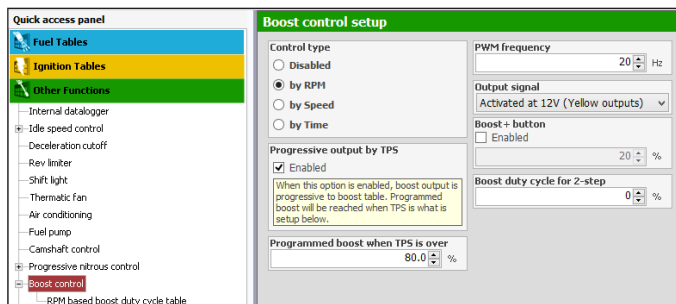

The first parameter is the output which will drive de boost solenoid. Select among the available outputs. After this, select the Boost+ input, in case of needing.

In the FTManager, this setting is done in the “Sensors and calibration”, then “Inputs” and “Outputs”.

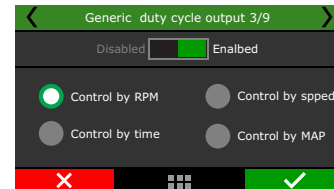
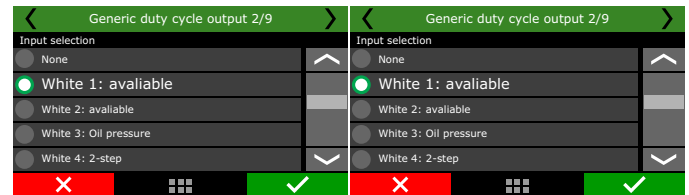

The next screen allows to quickly enable or disable the function and choose the control mode: by rpm, by time (after 2-step) or by speed.

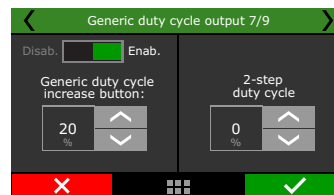
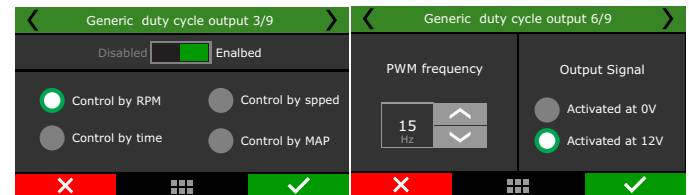

“Programmed boost when TPS is over” is the minimum TPS value to activate the boost solenoid. When the progressive output is selected, boost output is progressive to boost table, starting at 10% to the “Programmed boost when TPS is over” value.

- The recommended frequency for most PWM 3-way valve is 20Hz. The output signal depends on the solenoid installation. Check Chapter 13.8 for further information.
- Select if you want to use the Boost+ button.

The boost duty cycle for 2-step is the boost level when the 2-step is on, desconsidering any other boost table.

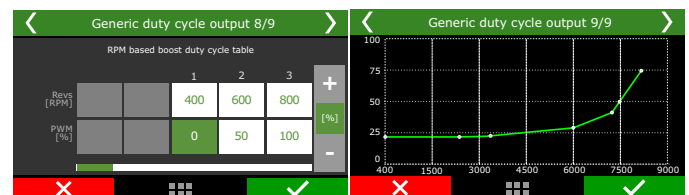

At last, there will be the boost duty cycle table by rpm, speed or time. The boost by time starts after the 2-step release.

19.14 Boost activated output

This function is used to activate an auxiliary output according to MAP readings.

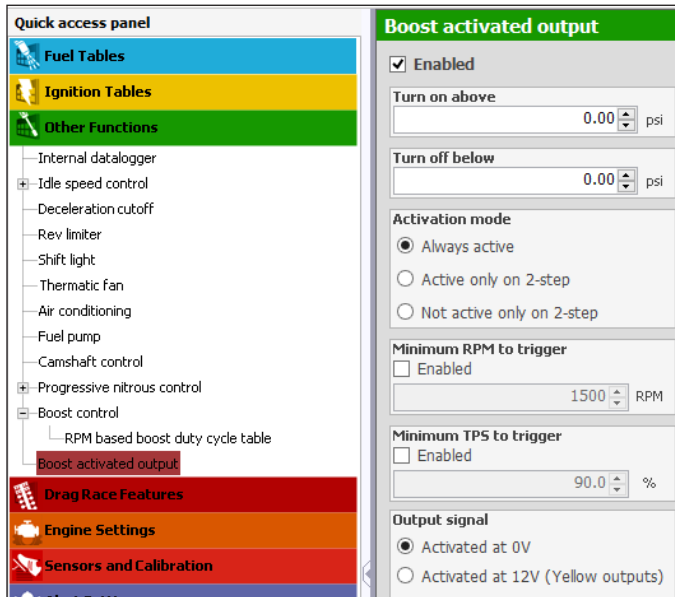

There are 3 different activation modes: “always active”, “active only on 2-step” or “Not active only on 2-step”. This means that even if the vacuum/boost conditions are met, the activation mode condition must be respected.

As safety features, minimum TPS and RPM values can be set, so the output will not activate if one or more conditions are not met.

19.15 Tachometer output

By default, the tach output is configured in the grey #8 wire, but can be set in the yellow wires also.

If one of this outputs are not available, the blue #1 to #8 and grey #1 to #7 can also be used, but an external 12V pull-up with a 1K resistor.

In the FTManager, this setup is at “Sensors and calibration” - “Outputs”

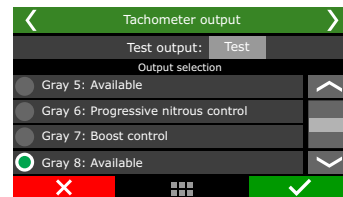

19.16 Wastegate boost pressure control

The active control function of the wastegate valve pressure is used for a more precise control of turbo pressure in street, circuit and, mostly, drag race cars. The control can be performed by time after 2-step, by gear and engine RPM, by gear elapsed time, by a single target or by engine RPM, besides specific targets for 2-step, 3-step and burnout mode.



IMPORTANT:

- The pressure controlled by BoostController is the pressure at the top of the wastegate valve.
- You can set the maximum MAP pressure and maximum MAP pressure on 2-step.
- When the BoostController is off the target is zero, and each time the read pressure, for any reason, exceeds 1.45psi the decrease solenoid is activated.

Select an available output to trigger a relay or any other external device.

In the FTManager, this setup is at “Sensors and calibration” - “Outputs”

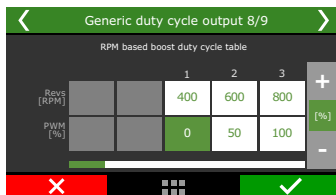

Select the output signal sent when it is activated. The only outputs capable of switch 12V are the yellow.

Define the vacuum/boost range to trigger the output.

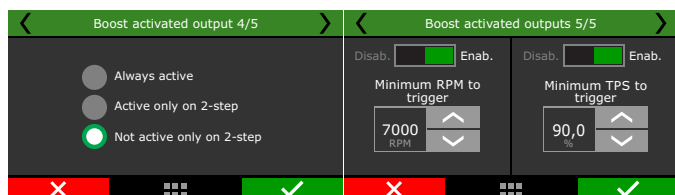

Installation diagram

- 1 - Decrease solenoid/injector trigger – connected to the blue or yellow output;
- 2 - Decrease solenoid;
- 3 - Increase solenoid/injector trigger – connected to the blue or yellow output;
- 4 - Increase solenoid;
- 5 - 12V from relay;
- 6 - Intake or CO2 bottle;
- 7 - Pressure sensor;
- 8 - Pressure sensor hose;
- 9 - Intake;
- 10 - Free air;
- 11 - Injectors block;
- 12 - 3 way Valve or N75;

- 13 - Actuation of 3 way valve or N75;
- 14 - Control pressure Wastegate;
- 15 - FT dual valve block;
- 16 - Connection to second Wastegate or must be blocked;

Diagram with regular solenoids

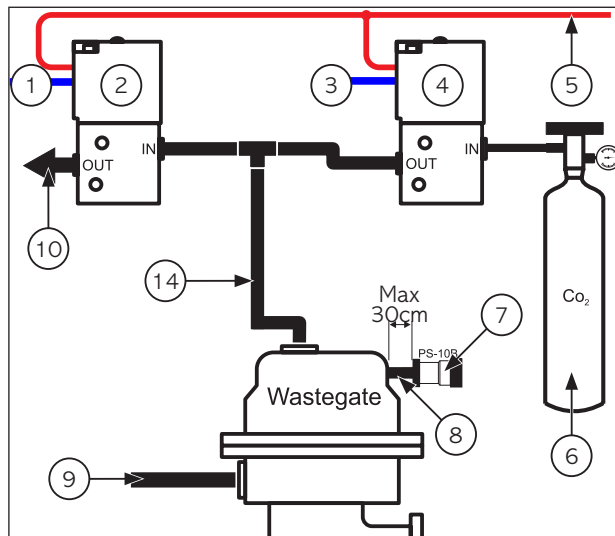

Diagram with injectors block

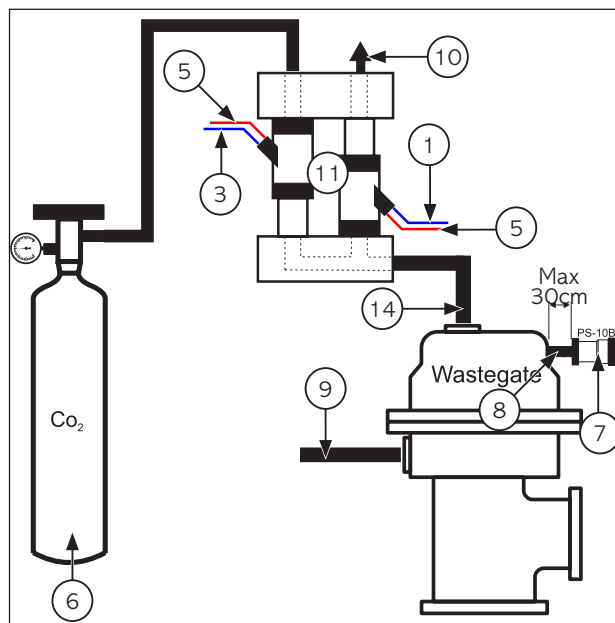

Diagram with 3 way Valve

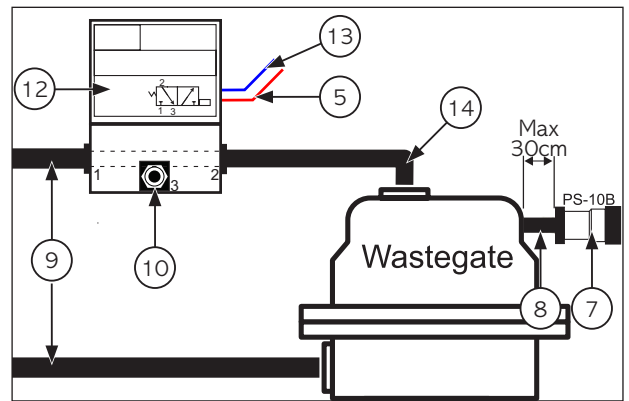

Diagram with FT dual valve block

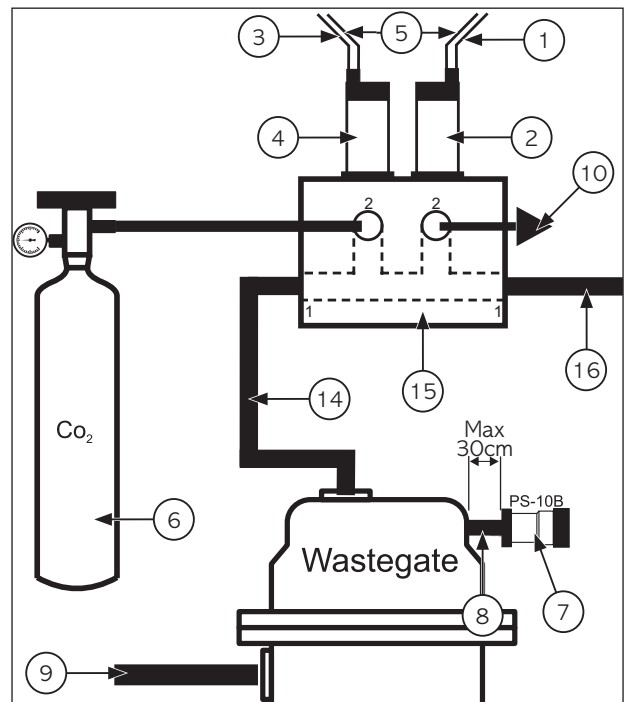
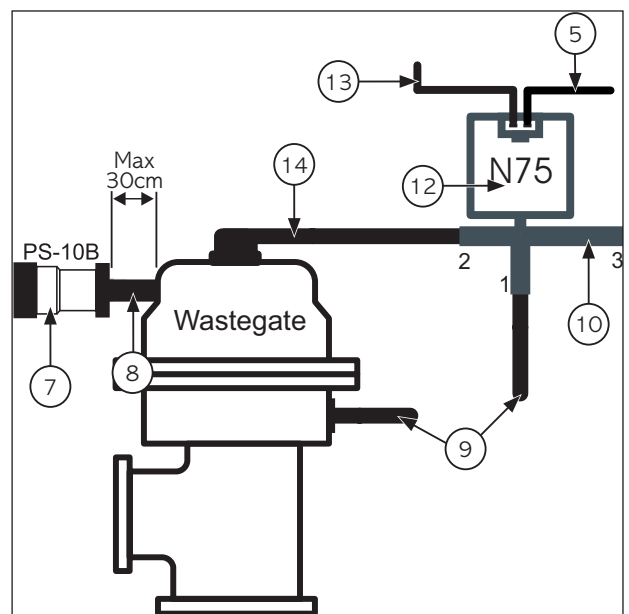
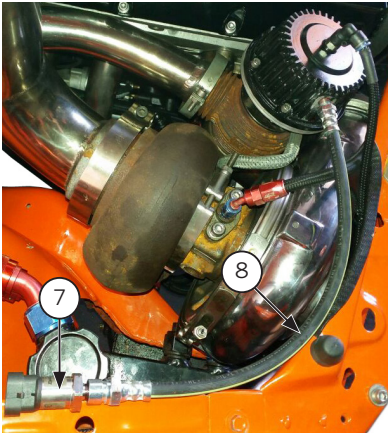

Diagram with N75 Valve





IMPORTANT:
Use a PS150 pressure sensor connected to any white input. Setup as "Wastegate pressure".



NOTE:
The pressure sensor (7) must be connected to the top of the wastegate with a hose (8) with a maximum length of 1ft. It prevents damage to the pressure sensor caused by vibration.



IMPORTANT:

- The pressure sensor must be installed on an exclusive line, and not shared with any other connection, to avoid reading errors.
- For the correct operation of the system, use only FuelTech PS sensors line: PS-150, PS-300, etc.



WARNING:
The boostcontroller test (when set as time based after 2-step) will only work with the engine turned off.
To test this feature with the engine running, a valid launch is required (when with the 2-step activated the engine hits TPS higher than 50% or the 2-step rev limiter).

FTManager setting

Through FTManager you can make all settings required for the operation of BoostController.

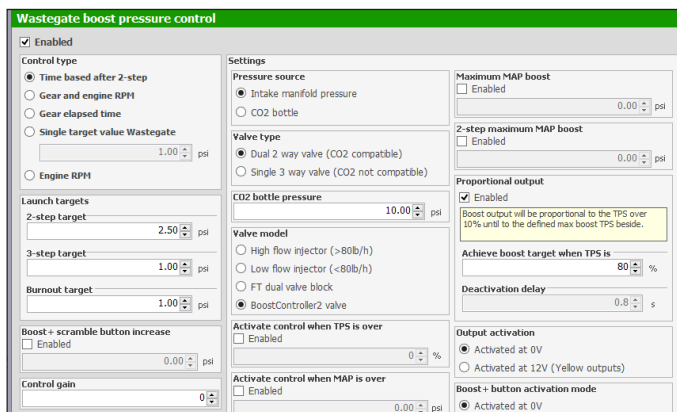

Set the input for the pressure sensor as PS-10B, PS-20B, PS-150 and PS-300 or BoostController2 MAP. In FTManager access the menu "sensors and calibration/inputs".

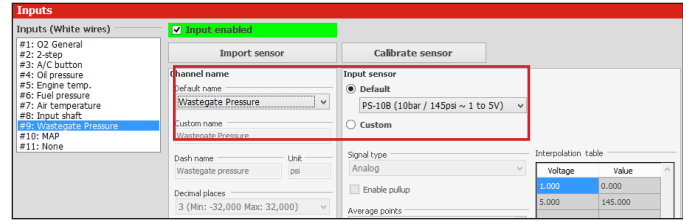

Set the outputs of the increase and decrease solenoid valves.

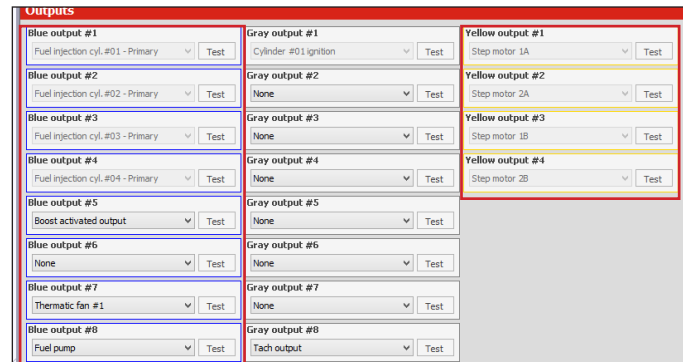

NOTE:
It is recommended to use the yellow or blue outputs for connecting the solenoids.



IMPORTANT:
Avoid using different color outputs for solenoids. Use two yellow outputs or two blue outputs.

In datalogger you can configure the channels for monitoring BoostController pressure.

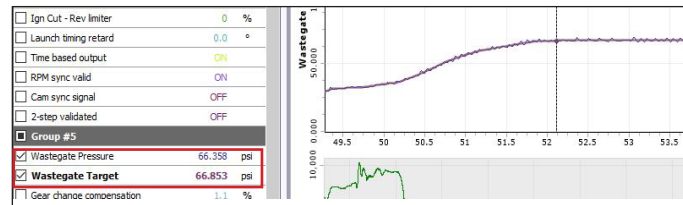

FT600 Input setting

In the "Sensors and calibration" menu select the "Wastegate pressure", after this set the associated input and the sensor type used.

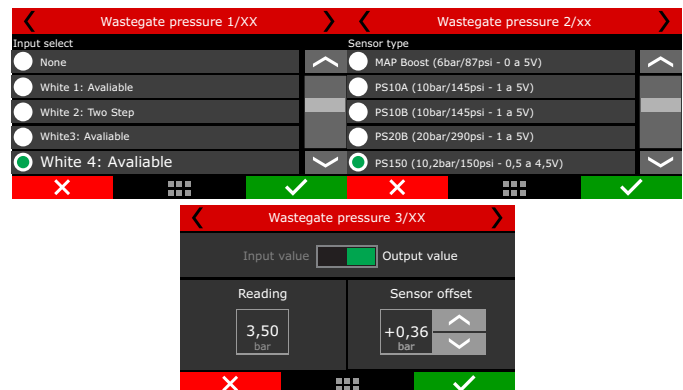

FT600 setting

In this menu should inform the BoostController its basic settings.

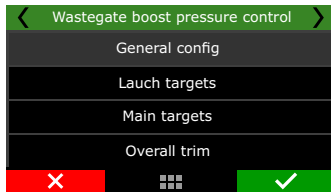

Basic: You can access all control settings through the FT600 screen.

Control gain: Adjust the control gain according to the valve response. If it is taking to achieve the target it is necessary to increase the gain, if it overshoots the target it is necessary to reduce this value.

Advanced (PC): Some settings are available only in FTManager software.

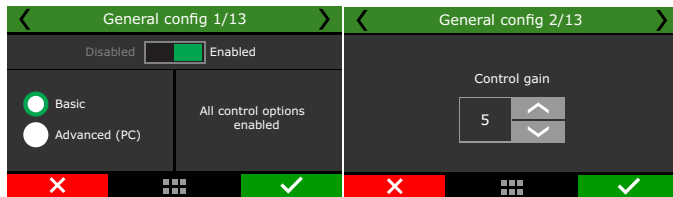

Pressure source: In the BoostController configuration will be necessary to inform what is your source of pressure: intake manifold or CO2 bottle.

When using a bottle, an industrial pressure regulator is required, limiting the line pressure according to the desired configuration. Two manometers must be used, one before the regulator indicating the pressure in the bottle and the other after the regulator showing pressure in the line.

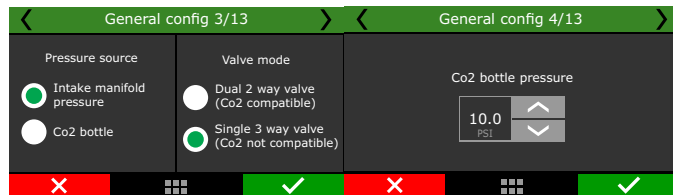

Valve model: You can choose which valve type will be used, high or low flow injectors, FuelTech 2 valve block or BoostController2 solenoid.

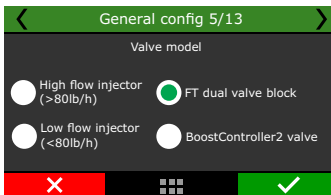

You can set a minimum value for BoostController activation by TPS and MAP.

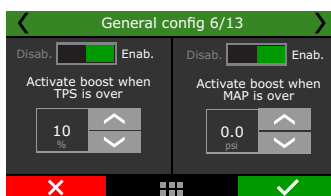

Proportional output: from 10% TPS the output is proportional to the map. The programmed pressure is reached when the TPS reaches the value set.

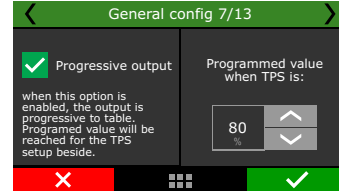

MAP maximum pressure and MAP maximum pressure on 2-step: Allow to set a MAP maximum pressure during 2-step and out of the 2-step. This function will not adjust the MAP pressure according to a target and will make the pressure bounces around the target. This maximum pressure must be used only as a safety feature to prevent overboost.



Output activation: the output can be triggered at 0V or 12V

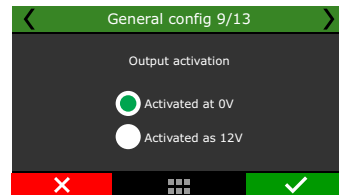

Set the solenoid trigger output

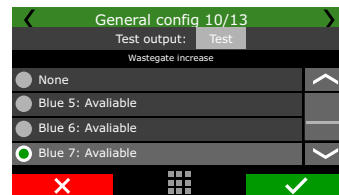

Boost+ button: Increases boost pressure while is switched on.

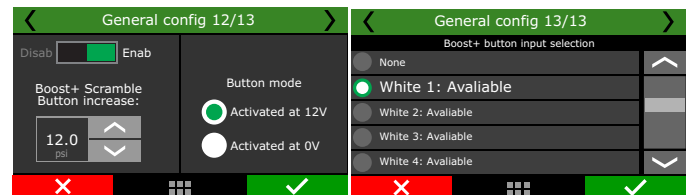

Launch targets

Defines the target pressure at the top of the valve in 2-step, 3-step and burnout mode.



2-step target: Set the target pressure during 2-step.

3-step target: Set the target pressure during 3-step.

Burnout target: Set the target pressure during burnout mode.



Boost maps

In this function you can set modes of boost maps by time after 2-step (single-stage), by gear and engine RPM (a stage for each gear), by gear elapsed time (a stage by each gear) and single value target.

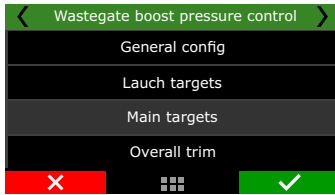

By time after 2-step: Allows a detailed ramp up to 32 time points. The intermediate values are interpolated.

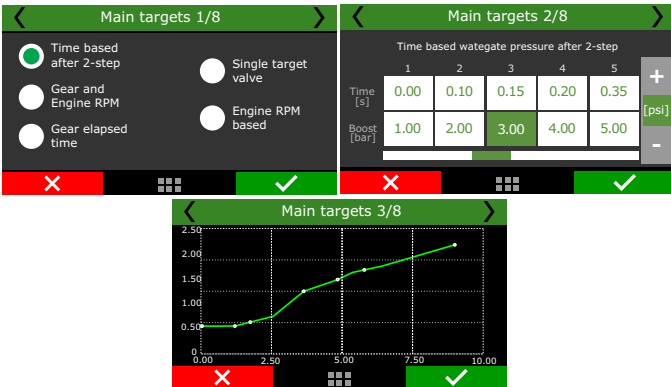

By gear and engine RPM: set up a stage for each gear, with up to 8 points per engine RPM. It is necessary that the gear change detection function is enabled. It does not depend on 2-step.

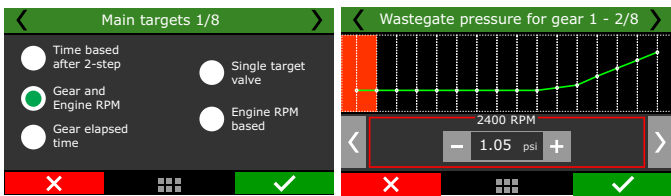

By gear elapsed time: Set up a stage for each gear, with up to 8 time points after the shift.

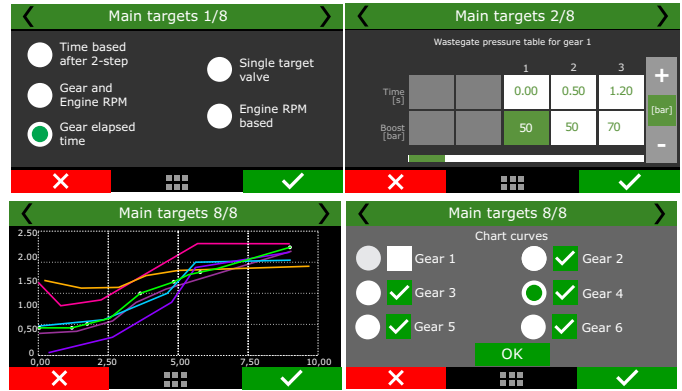

Single target value: Sets a fixed pressure for BoostController. The wastegate valve will always work this pressure.

This mode is recommended for dynamometer tests.

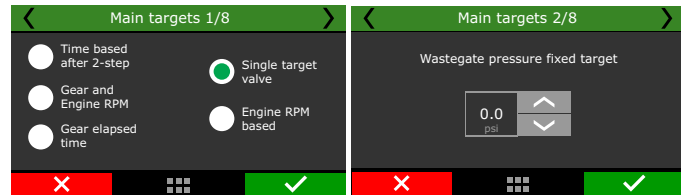

By engine RPM: Adjust the wastegate pressure according to the engine RPM only.

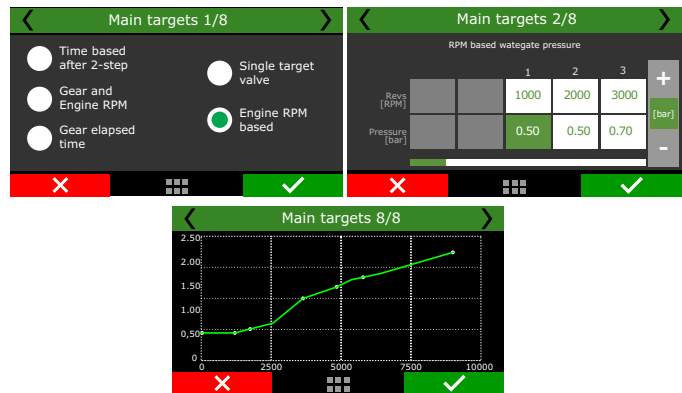

Overall Trim:

It is possible to do a target pressure o overall trim.



Target pressure overall trim is available to any kind of boost control type.



When boost control type is selected by gear, the overall trim can be individually applied.



NOTE:
Is mandatory to have gear change detection habilitated to use any kind of gear control.

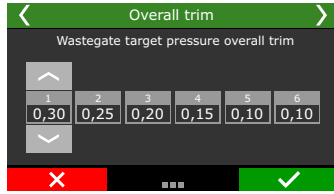

19.17 Power shift (GearController)

This feature allows gear shifting in manual transmission gearboxes (sequential or not) without the use of the clutch (flat shifts).



NOTE:
This feature can only be used on dog engagement equipped gearboxes. Synchronized gearboxes may be severely damaged when trying to shift gears without using the clutch, even if used with the power shift feature.

When this function is activated, the white inputs number 19 and 20 will be automatically setup as gear shifter force sensor.

It is possible to setup the ignition timing during the cut in two different ways: using the main timing table or using a fixed timing.

Main table: timing on gear shifts will use the values set in the main timing table.

Fixed timing: adjust the ignition timing according to the selected gear.

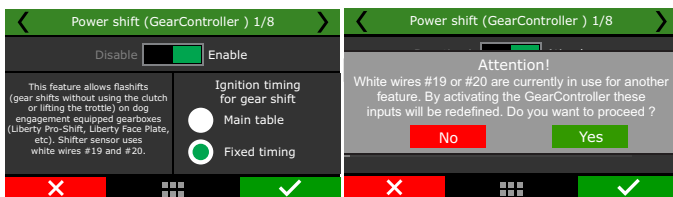

Cut duration: the cut duration configuration is adjusted in ms and the values are configurable by gear.

The cut duration is used to disengage the current gear, therefore, the next gear engagement is done by the mechanical system of the gearbox.

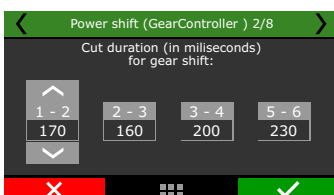

Fixed timing: this setting fixes the ignition timing during the gear shifts. It is configurable by gear.

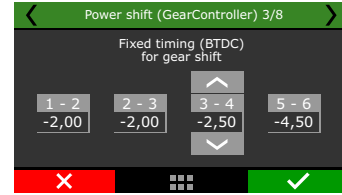

Set the % of the ignition cut for each gear.

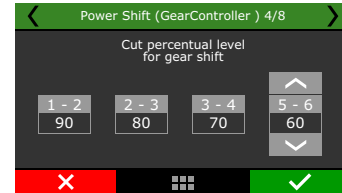

Shifter type: select the shifter type - H/Inline pattern or sequential shifter. Also select if your shifter is normal or inverted.

When forcing the shifter, check the voltage reading in the FT600 diagnostic panel or in the log, while shifting gears.

- If the voltage goes from 2.5V towards 5V, select the Normal shifter type.
- If the voltage goes from 2.5V towards 0V, select Inverted as shifter type.

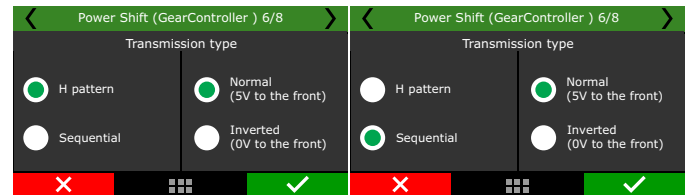

With the car stopped, push the shifter to the front and check the voltage read in the FT600 diagnostic panel. The recommended value is between 4 and 4.5V (or 0.5 and 1V - inverted transmission).

If the lever signal reaches 0V or 5V easily, lower the sensitivity gain in order to keep it below 5V and above 0V, the shifter voltages must never hit these limits.

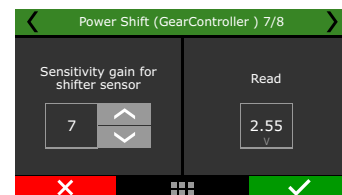

The shifter voltage cut level is used to disengage the current gear, therefore, the force to the back means the voltage to disengage odd gears (1st, 3rd, 5th) and force to the front refers to the cut to disengage even gears (2nd, 4th).

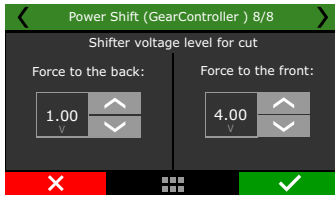

Power shift lever connection diagram

- 1- connect the blue wire from the shifter to the input #19 - white wire (pin 33 - FT600's B connector);
- 2- connect the orange wire from the shifter to the input #20 - white wire (pin 34 - FT600's B connector);
- 3- connect the two white wires from the shifter to the green/black wire from the ECU - sensors ground (pin29 FT600's B connector);

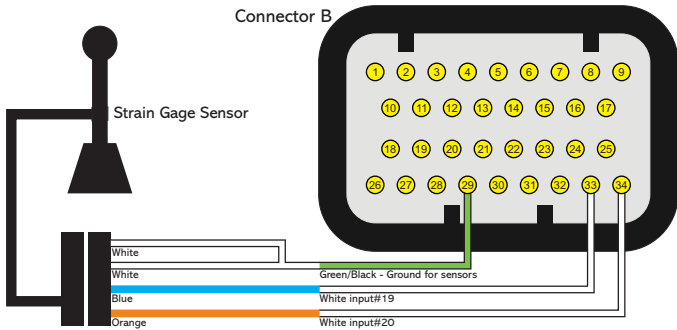

19.18 Start Button

This function allows the control of the vehicle's starter motor through an output (blue, gray or yellow wires) and an input (white wire) or through the FT screen.

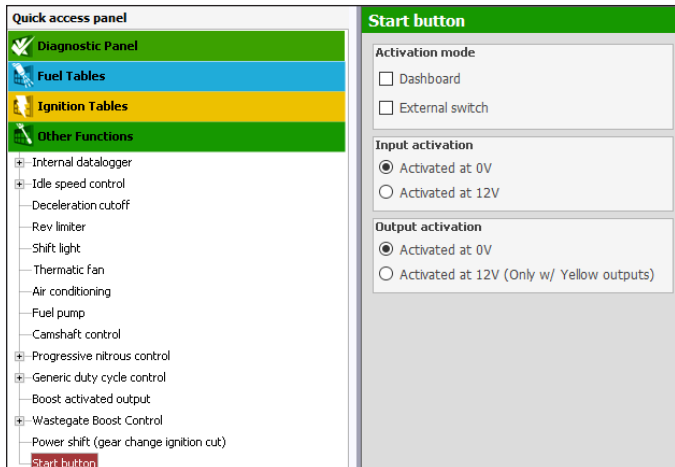

Select whether you want to start the engine through the FT LCD screen (must setup the "Start Button" item on the FT dashboard" or through an external switch

If Dashboard is chosen the starter motor remains engaged while the button is being pressed and until the engine RPM goes above the "RPM for engine start" (set in the Engine Setup menu". As soon as the engine is running, the function of the button on the dashboard is now changed to turn the engine off when pressed (by cutting fuel and spark).

When external switch is selected.

Select whether the input is activated when it receives 0V (ground) 12V. The output that activates the starter relay can be programmed whether to send 0V or 12V when activated.

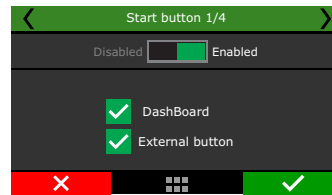

Select an output to activate the starter engine relay.

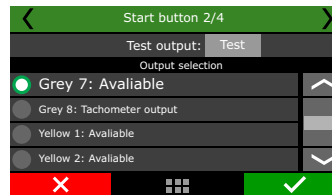

Select the input to the start button.

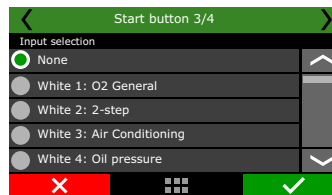

Define which is the activation signal to the input button and to the output if 12V or 0V.

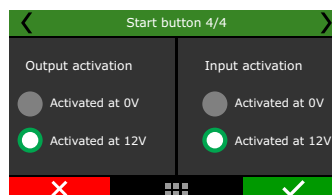

19.19 RPM activated output

This function allows enable output when the RPM is above a determined value.

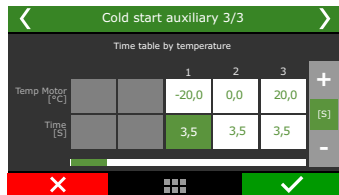
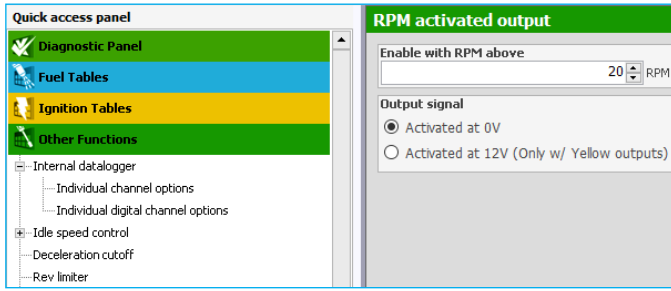

20. Drag race features

This menu gathers all options normally used in drag race applications. All the time based features start after releasing the 2-step button which indicates the moment when the vehicle launched.

20.1 Burnout mode

The Burnout Mode is a function used to facilitate the processes of warming up the tires and using the two-step.

When pressing the two-step button, the two-step function is activated.

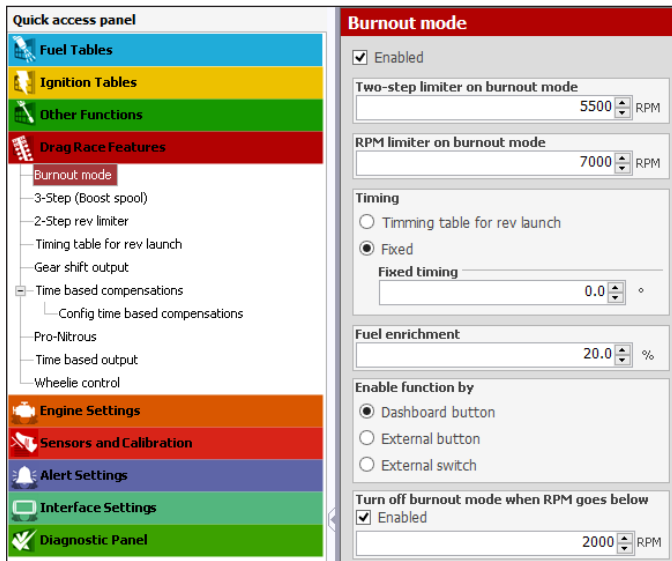

There are 3 different ways to enable the burnout mode:

- by dashboard button: a touchscreen button in the FT600 dashboard enables the function.
- by an external button* - a white input is required. One click to enable and another to disable the burnout mode.
- by an external switch* - similar to the button, but in this case the function is enabled while the input is grounded.

* In the FTManager, this setup is at "Sensors and calibration" - "Inputs"

The burnout mode can be automatically disabled by RPM. When the engine RPM is below an editable value. This option is not available for "external switch" option.

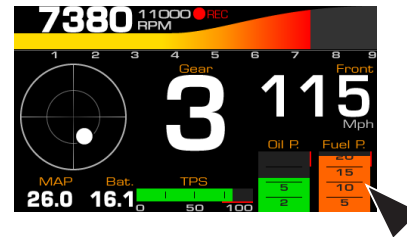

20.2 3-step (boost spool)

The 3-step is quite similar to the 2-step function, however, with proper parameters and even more aggressive to assist in the boost spool.

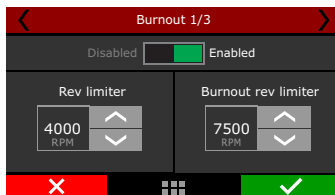

When Burnout mode is activated, it disables the standard RPM Limiter, instead the ECU uses this RPM limiter as the engine's RPM limit.

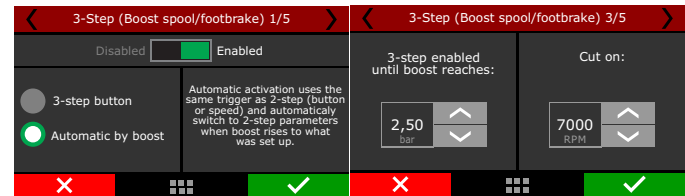
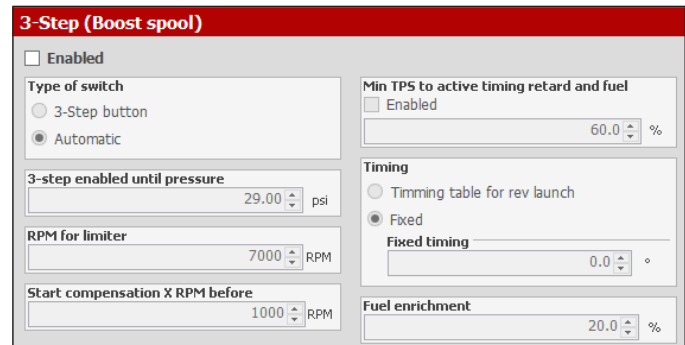
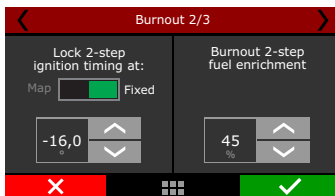

There are two ways to activate this function, one uses an external button (must use a white wire attached to a button, usually on the foot brake) and the other is through 2-step button.

In this case, you must press the 2-step button and the 3-step will be activated until the engine reaches a predefined boost pressure, at this point the 3-step will be deactivated and the 2-step will be activated. If using an external button to trigger the 3-step, when it is triggered simultaneously with 2-step button, the 2-step will prevail.

But when the two-step button is being pressed, the value considered is the one set for the two-step parameter. The values adopted for ignition timing retard and enrichment are the ones configured on the two-step function.

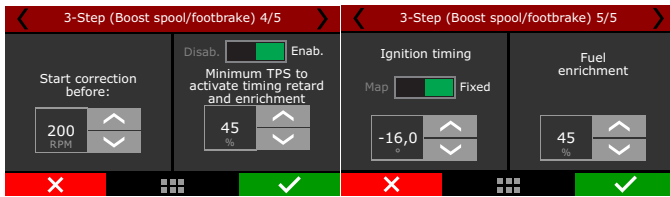

It is possible to start the 3-step mode before the RPM rev limiter and to set a minimum TPS value to activate it.

20.3 2-step rev limiter

The two-step active with a retarded ignition timing, and a mixture enrichment given in percentage (also programmable).

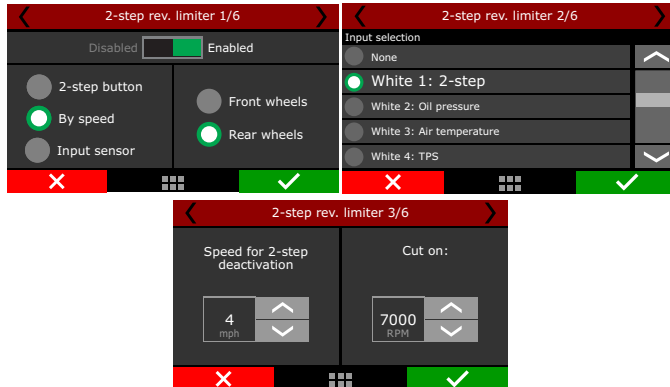

When pressing the two-step button, usually installed on the steering wheel or driven by a launch control / transbrake switch, the system activates an ignition cut in a programmable RPM.

In the FTManager, this setup is at "Sensors and calibration" - "Inputs"

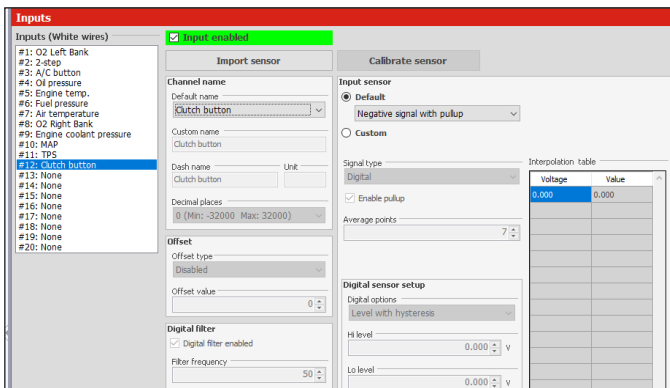
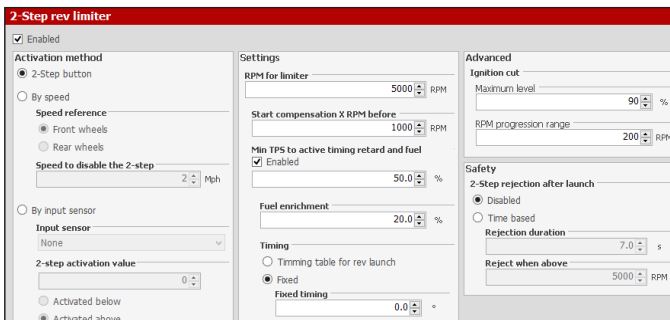

Clutch switch: for drag racing vehicles with manual transmission and clutch, this switch tells the ECU whenever the pedal is pressed. Connected to a white input.

This is an auxiliary feature to the 2-step and it helps releasing the 2-step at the same moment the clutch is being released.

If the clutch switch is pressed when the 2-step is deactivated, nothing happens, but, if the 2-step is active, then the clutch switch will hold the 2-step enabled until the clutch is released. The 2-step button can be released after this that the 2-step feature will still be active.

The 2-step button still works as usual. The clutch switch is fully optional.

Clutch switch electrical diagram

Connect the clutch switch to any white input and setup this input through the FTManager or through the screen. The other side of the clutch switch must be connected to the battery negative or chassis.

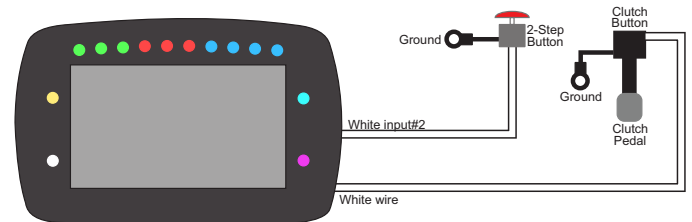

Line lock

Use a yellow output to control the line lock solenoid and setup this output as Line Lock through the FTManager or the screen. The other side of the solenoid must be connected to the battery negative or chassis.

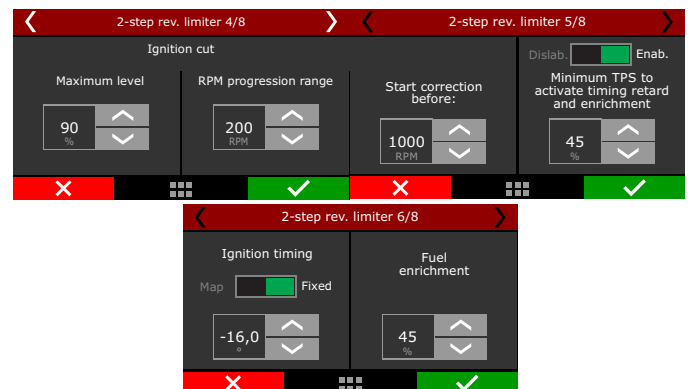
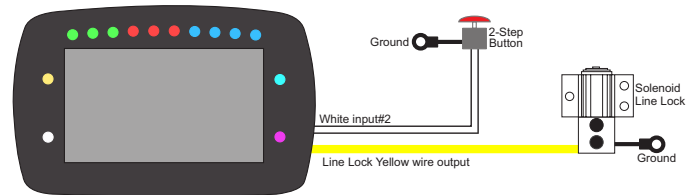

It is possible to set the ignition cut maximum level, that is the percentage of ignition events cut to keep the engine under the rev limiter.

The RPM progression range acts as a smoothing for ignition cut.

Example: rev limiter at 8000rpm, RPM progression range at 200rpm. From 8000rpm the ignition cut level will gradually increase until it reaches 90% cut at 8200rpm.

Percentages less than 90% may not keep the engine under the rev limiter. Bigger RPM progression range tend to stabilize more smoothly the rev limiter, but allows the RPM to pass the RPM set as rev limiter.

These numbers are valid to all kinds of ignition cut, with the exception of time based compensations (time based RPM and driveshaft RPM/ wheel speed) and 2-step. These features have their own parameters.

For inductive ignition systems it is recommended to use 90% maximum level and 200 RPM progression range. For capacitive system, like MSD, it is recommended to use 100% maximum level and 1 RPM progression range.

The "Start compensation X RPM before" helps to spool the turbo and have a more stable rev limiter.

The minimum TPS to activate timing retard and fuel enrichment allows the driver to hold the engine in the rev limiter without any compensation when not needed.

The time based compensations will only work after the release of a valid 2-step. This means hold the 2-step button with more then 50% TPS or reach the rev limiter on time at least.



ATTENTION:

When the 2-step is by wheel speed, its working can be checked through the first page of Diagnostic Panel, since it is not being used any 2-step button input.

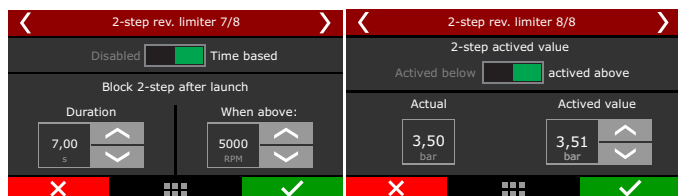

To prevent the driver to activate the 2-step on a run, there are 2 safety parameters. Block 2-step by time or by RPM. This way, even if th driver press the 2-step button, it will not activate before the time slip or above the RPM.

When using the 2-step by an input sensor, you must indicate an above or below value which the 2-step must be considered active.

2-Step warning LEDs

2-step without valid launch condition: Yellow

2-step with valid launch condition (ign cut or TPS): Green

Invalid launch: Red blinking for 5 seconds

Valid Launch: LED is turned off (it would be green until a valid launch)

2-step + staging control: Blue

Staging control button without 2-step: Purple

Active function tables

The following tables show what will be the active function with the 2-step and 3-step combinations

2-Step: Button	3-Step: Button	
<i>Button 2-step</i>	<i>Button 3-step</i>	<i>Active function</i>
Pressed	Pressed	3-step
Pressed	Released	2-step
Released	Pressed	3-step

2-Step: Button	3-Step: Auto	
<i>Button 2-step</i>	<i>MAP pressure</i>	<i>Active function</i>
Pressed	Lower than target	3-step
Pressed	Higher than target	2-step

2-Step: Speed	3-Step: Button	
<i>Speed</i>	<i>Button 3-step</i>	<i>Active function</i>
Lower than target	Released	2-step
Lower than target	Pressed	3-step
Higher than target	Pressed	3-step

2-Step: Speed	3-Step: Auto	
<i>Speed</i>	<i>MAP pressure</i>	<i>Active function</i>
Lower than target	Lower than target	3-step
Lower than target	Higher than target	2-step

2-Step: Sensor	3-Step: Button	
<i>Sensor</i>	<i>Button 3-step</i>	<i>Active function</i>
Active condition	Released	2-step
Active condition	Pressed	3-step
Not Active condition	Pressed	3-step

2-Step: Sensor	3-Step: Auto	
<i>Sensor</i>	<i>Button 3-step</i>	<i>Active function</i>
Active condition	Lower than target	3-step
Active condition	Higher than target	2-step

2-Step: CAN	3-Step: Button	
<i>Button 2-step CAN</i>	<i>Button 3-step</i>	<i>Active function</i>
Pressed	Pressed	3-step
Pressed	Released	2-step
Released	Pressed	3-step

2-Step: CAN	3-Step: Auto	
<i>Button 2-step CAN</i>	<i>MAP pressure</i>	<i>Active function</i>
Pressed	Lower than target	3-step
Pressed	Higher than target	2-step

20.4 Linelock Brake Control

This function allows the use of a line lock solenoid to keep the brake line of the trailing wheels pressurized and to facilitate the exit, avoiding that the pilot has to modulate the brake with the foot at the time of the exit. For correct use of this function press the brake pedal, operate the 2-step, release the brake pedal and the line lock will be activated. When you release the 2-step, the Line Lock solenoid is automatically disabled. Select whether to activate the line lock on burnout, 3-step and / or 2-step modes.

An output must be configured as "Output line lock".

Brake pressure control: This function enables brake pressure control through a PWM curve. This is used to lower the brake line pressure to a desired value and standardize the launches.

It is necessary.

A white input must be setup as "Brake pressure".

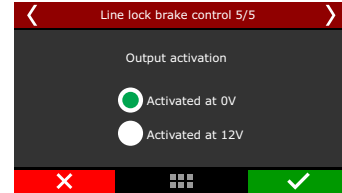
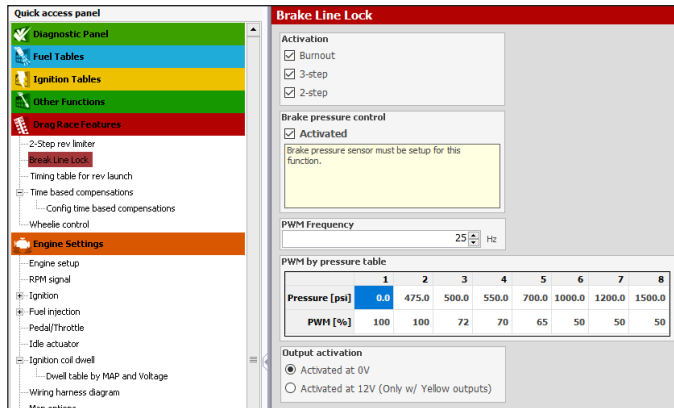

20.5 Timing table for rev launch

This timing table is only used for burnout mode, 2-step and 3-step. This is not a compensation table, but a table with absolute timing values, which ignores any other timing table or compensation.

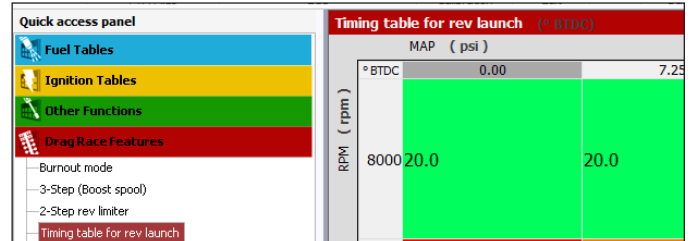

20.6 Gear shift output

This feature allows switching on an external solenoid to shift the gears. The activation strategy can be either by a fixed RPM value for all the gears or different RPM for each gear just like the shift light feature.

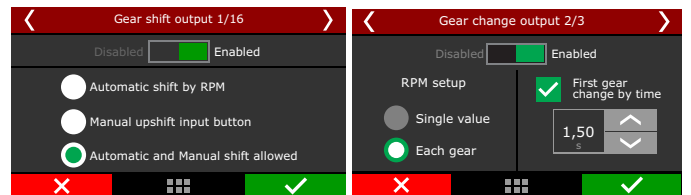
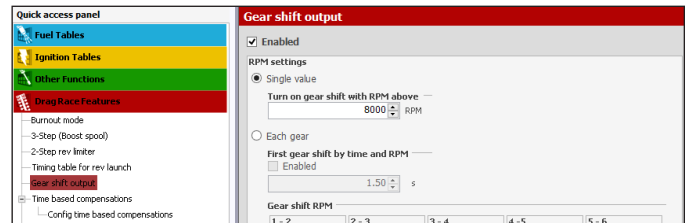

Select the desired output, all the outputs will be displayed, except the ones used for injection and ignition. In the FTManager, this setup is at "Sensors and calibration" - "Inputs".

The gear shift by single value sends a signal every time the engine reaches the selected RPM. When using the each gear mode, each gear shift will be on its own RPM. To use this mode the gear detection must be activated.

The gear shift is enabled after the 2-step is released, so, after the last gear the 2-step must be activated again to perform the shifts again. When selecting this mode, the "First gear shift by time and RPM" will be available. It allows the gear shift to be performed not only by RPM, but also by time. This means that there are 2 conditions (time and RPM) to be met to gear shift. It is not possible to use this control with automatic transmissions with more than one solenoid.

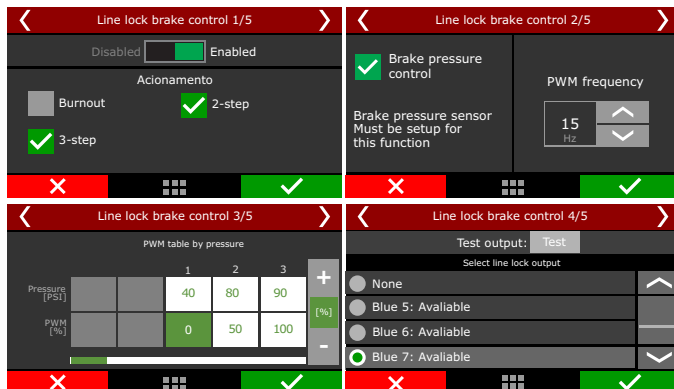

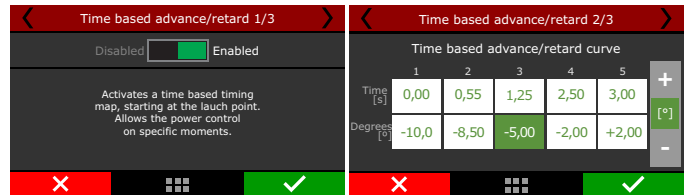
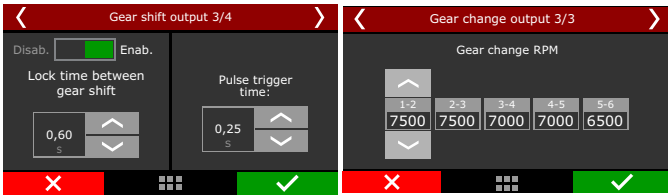

20.7 Time based fuel enrichment

Enables a time based fuel compensation that starts after the 2-step deactivation. This compensation is a time (seconds) versus compensation (%) feature. After you enter the table, a graph will be displayed.

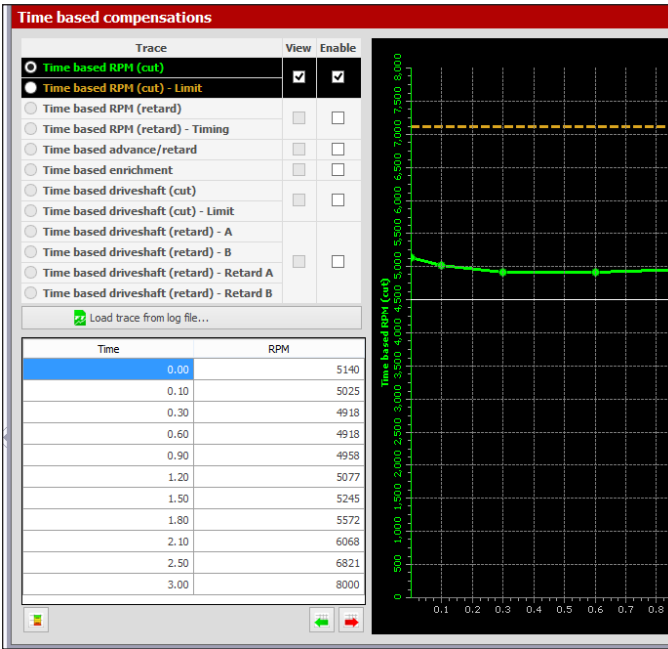

Time based advanced/retard timing

Enables a time based timing compensation that starts after the 2-step deactivation. This compensation is a time (seconds) versus degrees BTDC (° BTDC) feature. After you enter the table, a graph will be displayed.

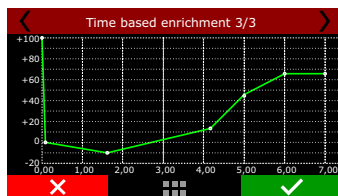

Time based revolution limiter

The RPM control is based on seven RPM and time points that can be determined as shown in the image above.

This function is frequently used in drag racing cars, because it makes it easier to control the vehicle, once it allows the traction to be recovered through an ignition cut ramp.

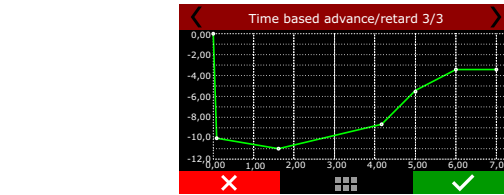

Time based speed (cut)

This feature is the same as the time based RPM (cut) but instead of using the engine RPM, it uses the wheel speed or the driveshaft RPM.

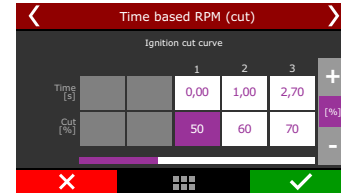

It will perform ignition cut to keep the wheel speed/driveshaft RPM under a predefined curve.

The "Time based RPM (cut) - Limit" is the maximum level, which means the percentage of ignition events that will be cut to keep the engine under the rev limiter.

The RPM progression range acts as a smoothing for ignition cut.

Example: rev limiter at 8000rpm, RPM progression range at 200rpm. From 8000rpm the ignition cut level will gradually increase until it reaches 90% cut at 8200rpm.

Percentages less than 90% may not keep the engine under the rev limiter. Bigger RPM progression range tend to stabilize more smoothly the rev limiter, but allows the RPM to pass the RPM set as rev limiter.

For inductive ignition systems it is recommended to use 90% maximum level and 200 RPM progression range. For capacitive system, like MSD, it is recommended to use 100% maximum level and 1 RPM progression range.

The last screen will show the graph.

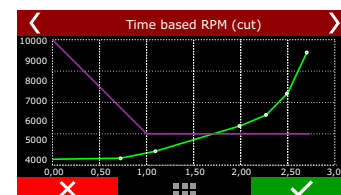

Time based RPM (retard)

This feature is very similar to the time base RPM (cut), instead of cutting the ignition, it will retard the timing, to have a smoother way to control power and torque to the wheels. The function starts after 2-step.

It is recommended to use this function together with the Time based RPM (cut) to have a better control of the engine, this way the control itself will be smoother.

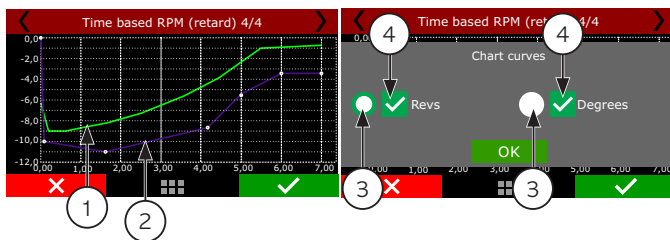
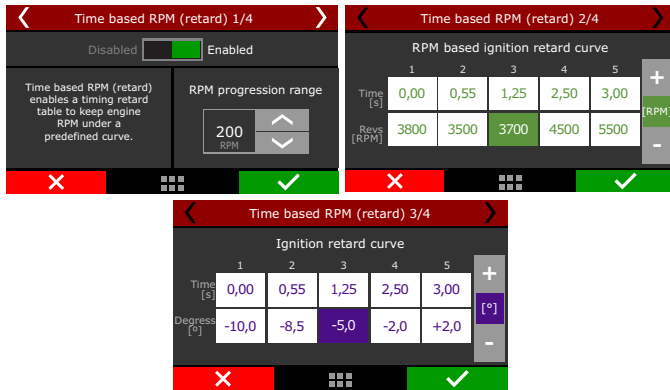

- 1 - Green Speed curve;
- 2 - Purple speed curve;
- 3 - Buttons for chart selection that will be in the upper layer;
- 4 - Check boxes to enable or disable graphic display;

Time based speed (cut)

This feature is the same as the time based RPM (cut) but instead of use the engine RPM, it uses the wheel speed (with a wheel speed sensor or by calculate speed) or the driveshaft RPM. It will perform ignition cut to keep the wheel speed/driveshaft RPM under a predefined curve. Generally speaking, this speed/RPM control searches to limit the wheel speed during the run.

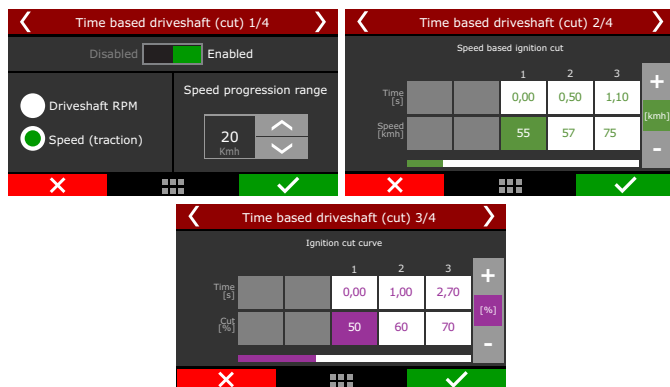

The first screen will briefly explain how the feature works and it will ask what the speed reference is, if it is a wheel speed or drive shaft RPM. You must have a wheel speed sensor or a driveshaft RPM sensor enabled to use this feature.

The first parameter to be set is the speed/RPM progression range, which is the Speed/RPM range from start the ignition cut to its maximum level.

A 10 Mph speed progression range means that if your control starts at 80 Mph, the ignition cut maximum level will be at 90 Mph.

The next screen is the wheel speed/driveshaft RPM versus time table. After the 2-step, every time the speed/RPM goes above the curve, the ECU will perform ignition cuts.

Percentages less than 90% may not keep the engine under the rev limiter. Bigger RPM progression range tend to stabilize more smoothly the rev limiter, but allows the RPM to pass the RPM set as rev limiter.

For inductive ignition systems it is recommended to use 90% maximum level and 200 RPM progression range. For capacitive system, like MSD, it is recommended to use 100% maximum level and 1 RPM progression range.

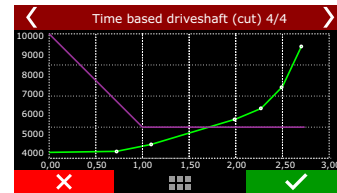

Time based speed (retard)

This feature reads the wheel speed (or the driveshaft RPM) and applies ignition compensation, according to the two RPM curves (A and B) to control launch.

The basic idea is to retard the ignition timing, reducing power to the wheels. When the wheel speed reaches the programmed in the "speed curve A", the ECU starts the programmed retard in the "delay curve A point".

As the speed increases, and goes toward the curve "B" speed, the retard applied to the timing (that is interpolated between the two retard curves) is incremented. Thus, if the initial retard made by curve A is not sufficient to hold the speed of the vehicle, the retard will increase as much as the RPM increase.

In cases where the speed/RPM exceeds the limits of the curve "B", the maximum retard (entered in curve B) will be applied.

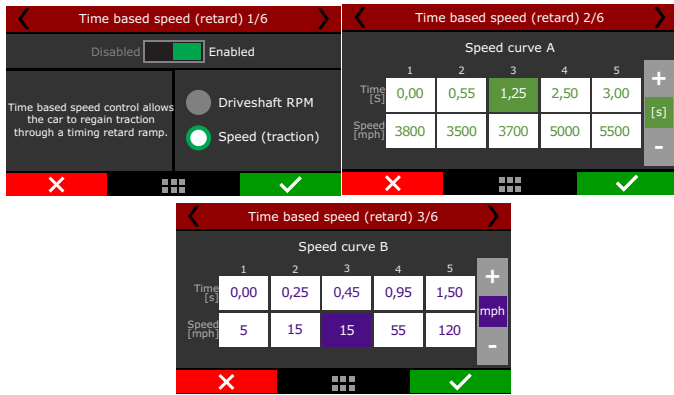

The first screen allows to select the speed/RPM reference (wheel speed or driveshaft RPM). You must have a wheel speed sensor or a driveshaft RPM sensor enabled.

The next screens will show the speed/RPM curves A and B.

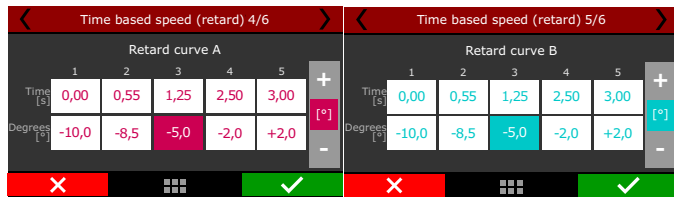

After this, the ignition retard curves A and B

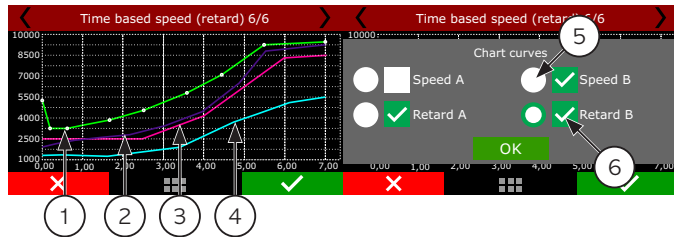

- 1 - Green speed curve A;
- 2 - Purple speed curve B;
- 3 - Pink timing retard curve A;
- 4 - Blue timing retard curve B;
- 5 - Buttons for chart selection that will be in the upper layer;
- 6 - Check boxes to enable or disable graphic display;

In the end, a graph will be displayed with all the curves (speed/RPM A and B, retard A and B)

Note that the speed and retard curves shown on the graph form speed and retard zones. They have the following characteristics:

- When below the curve A, there is no retard applied to the engine;;
- When the speed/RPM is equal to the programmed curve A, the ignition retard is equal to the programmed in curve A;
- For speed/RPM between the two curves, the retard is interpolated, in other words, the more the speed/RPM exceeds the curve A towards to curve B, the more retarded will be the timing;
- If the speed/RPM programmed is overcoming the curve B, the ignition retarded is equal to the programmed in curve B.

20.8 Pro-Nitrous

This feature controls up to 6 time based nitrous stages, with individual settings for each stage.

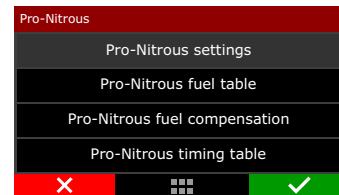
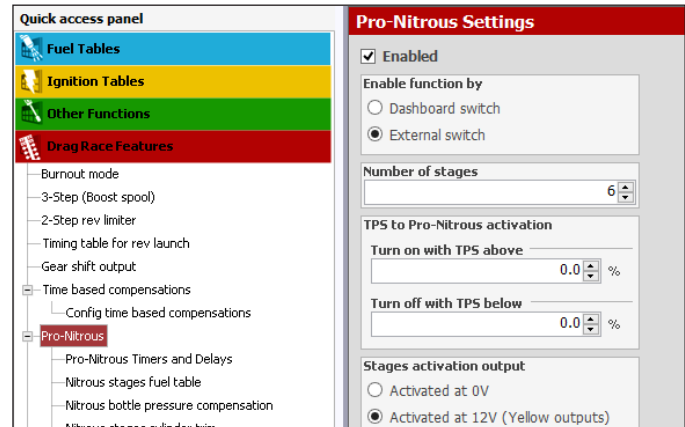

Pro-Nitrous settings

To activate the Pro-Nitrous it is mandatory fulfill 3 requirements:

1. Active the Pro-Nitrous button (external switch in one of the white inputs or a dashboard button in FT600 display).
2. The elapsed time after 2-step cannot be more than 15s, otherwise Pro-Nitrous will not be turned on. In other words, the vehicle must launch in less than 15s after 2-step deactivation.
3. TPS must be above minimum configured.

With these 3 requirements fulfilled, the Pro-Nitrous stages will start and follow the configured time. The fuel and timing compensations will also start at this point. If any condition fail, the Pro-Nitrous is deactivated and FT600 will use fuel, timing and O2 closed loop main tables.

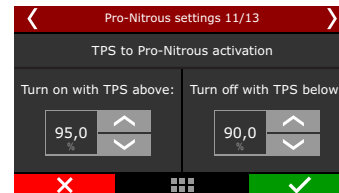
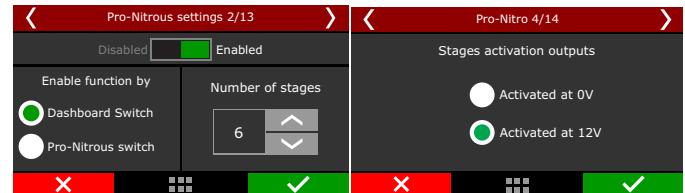

The first parameter to be set is the enabling mode:

- Dashboard button: a touchscreen button in the LCD screen that can be found in the Dashboard settings menu.
- External switch: a white input must be used in an external switch. While the input is grounded, the Pro-Nitrous will be on.

FuelTech FT600 allows firing the solenoids by switching 12V or OV (ground), which must be setup in the grays or yellow outputs. All the Pro-Nitrous inputs and outputs can be set both by touchscreen or FTManager, in the "Sensor and calibration" menu.

Pro-Nitrous has two different TPS limits. One limit is to turn on with a minimum TPS, the other is to turn off with a maximum TPS. The recommend is set the TPS to turn on at least 5% higher than the TPS to turn off. This way there will be a hysteresis that won't let Pro-Nitrous turn on and turn off several times when TPS is around activation TPS. Also, you will be able to pedal the throttle to get back traction.

The RPM activation window is necessary to protect the engine, not allowing having a nitrous shot in a low RPM or by deactivating nitrous before the rev limiter

The Pro-Nitrous timers and delays table gathers the on and off settings for stages and compensations. A pedaling delay can also be set, so, if the driver pedals in a run, the Pro-Nitrous can be reactivated progressively.

In the FTManager, this table is as shown below.

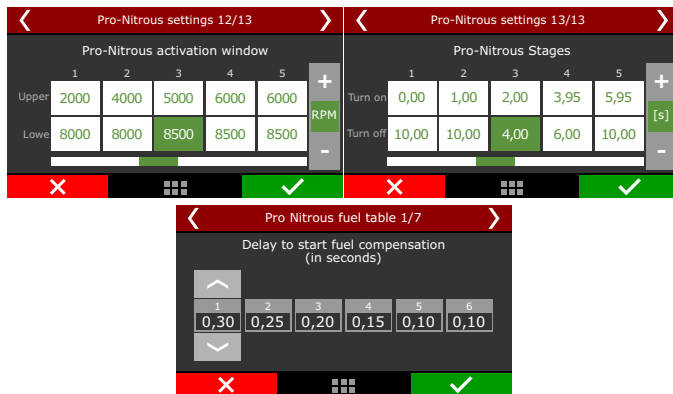

Pro-Nitrous Timers and Delays						
	Stage #1	Stage #2	Stage #3	Stage #4	Stage #5	Stage #6
NOS stage timers						
ON after launch	0.00	0.00	0.00	0.00	0.00	0.00 s
OFF after launch	0.00	0.00	0.00	0.00	0.00	0.00 s
ON after pedaling	0.00	0.00	0.00	0.00	0.00	0.00 s
NOS fuel compensation						
ON delay	0.00	0.00	0.00	0.00	0.00	0.00 s
OFF delay	0.00	0.00	0.00	0.00	0.00	0.00 s
OFF ramp	0.00	0.00	0.00	0.00	0.00	0.00 s
NOS ignition timing compensation						
ON delay	0.00	0.00	0.00	0.00	0.00	0.00 s

Pro-Nitrous fuel tables

Here all the fuel compensation for Pro-Nitrous can be configured according to each stage.

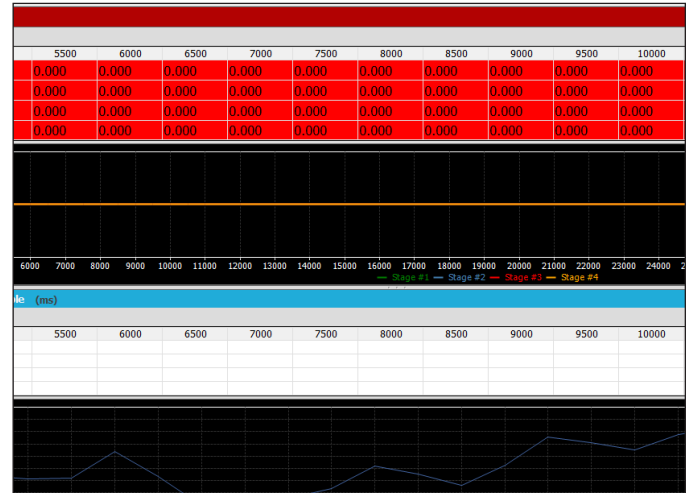
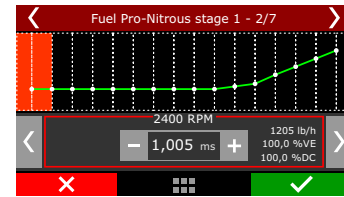
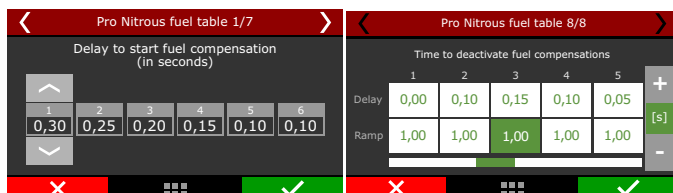

On the first screen is the configuration that allows setting a delay to start the fuel compensation, based on the time that the nitrous shot takes to get to the combustion chamber.

After the delay, there are the fuel tables to each stage. You can program the fuel compensation over RPM and it is calculated considering the main fuel table.

Since the injectors are closer to the combustion chamber than the nozzles/foggers, the purpose is that the fuel and nitrous get to the combustion chamber at the very same time.

In the FTManager software is possible to visualize the total calculated fuel table.

It is possible to set an OFF delay and OFF ramp after each stage. It helps because moments after shut down the nitrous solenoid, the intake still full of nitrous that will be consumed by the engine.

Nitrous stage cylinder trim and bottle pressure compensation

- This is a fuel injection cylinder trim for the Pro-Nitrous feature.

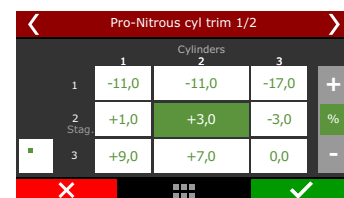

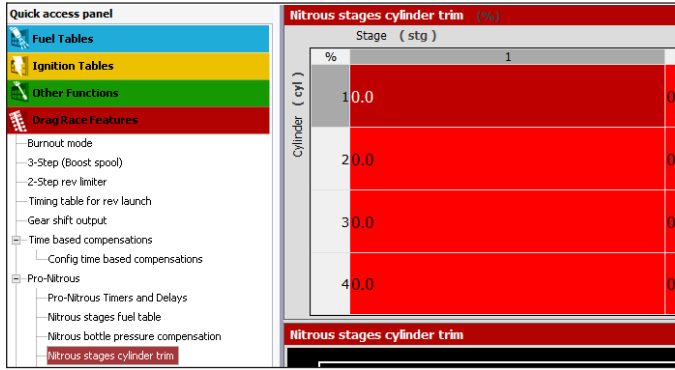

- **Bottle pressure compensation:** compensates the bottle pressure drop that happens in a run. The bigger the nitrous consumption, the bigger the pressure drops, and consequently the nitrous mass is smaller. With this, less fuel is necessary.

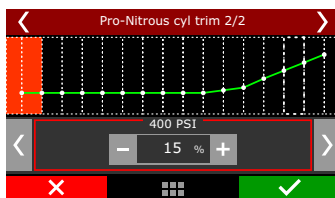

Nitrous stage timing tables: After the delay, there are the timing tables to each stage. You can program the timing compensation over RPM and it is calculated considering the main timing table. In the FTManager software is possible to visualize the total calculated ignition table.

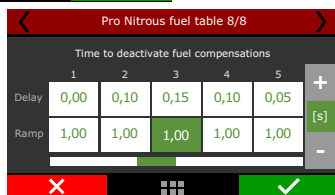
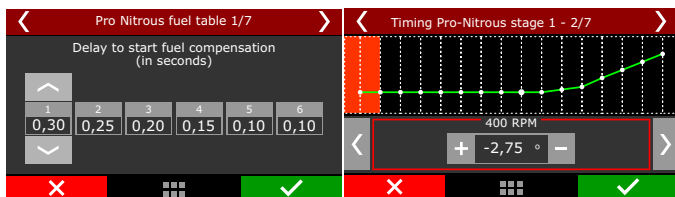
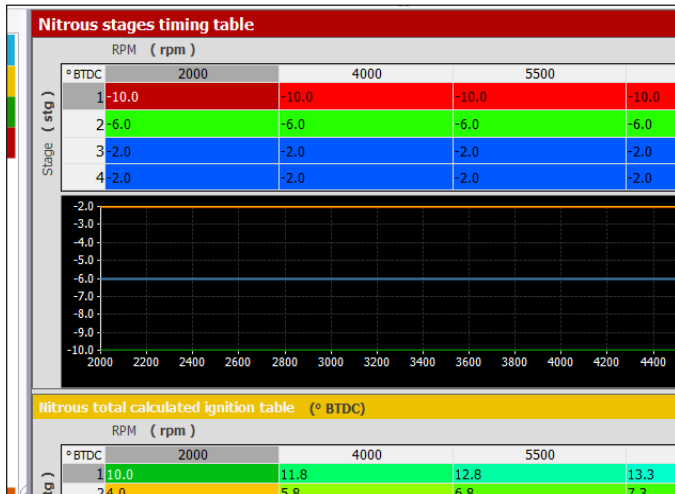

20.9 Time based output

This feature allows activating an auxiliary output by time, which can be used to release the parachute, turn on the nitrous or even switch on the torque converter lockup solenoid.

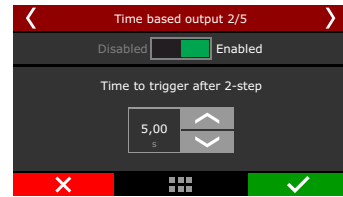
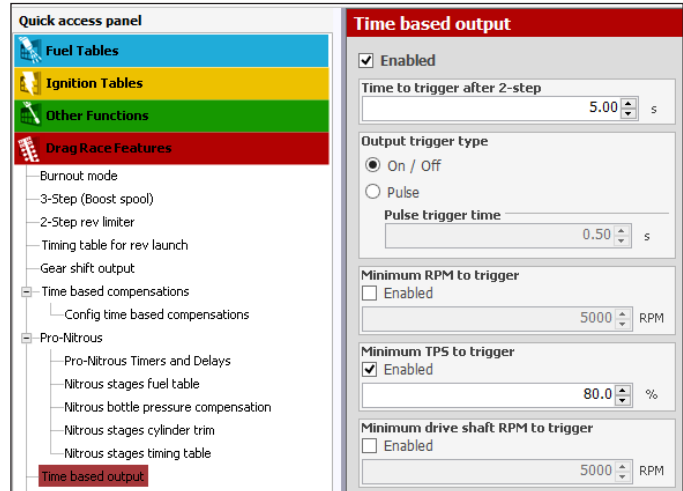

Also, there are conditions, besides time, to trigger the output. The conditions are: minimum RPM, minimum TPS, minimum driveshaft RPM and minimum wheel speed.

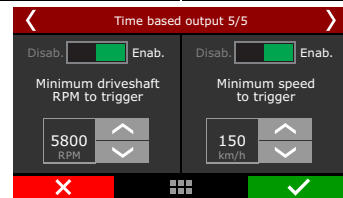
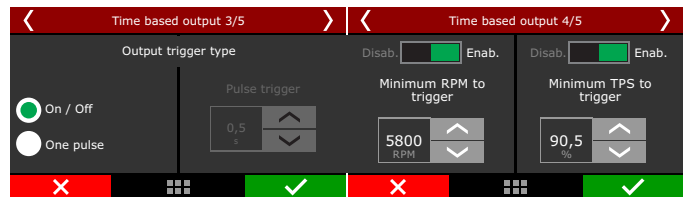

All this options can be enabled or disabled. The output signal can be an ON/OFF signal (remaining on while the conditions are valid) or a pulse (to release the parachute, for instance), which the duration is programmable

The available activation conditions are: minimum RPM, minimum TPS, minimum driveshaft RPM.

If the output trigger type is ON/OFF, when one of the conditions stop being met, the output is turned off.

When activated, the output switches to 0V. In the FTManager, select the output in the "Sensors and calibration" menu, then "Outputs".

20.10 Wheelie Control

This function uses the reading of height and pitch sensors to avoid the car to wheelie. It is recommended to rear wheel drive cars and bikes.

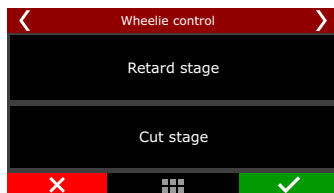
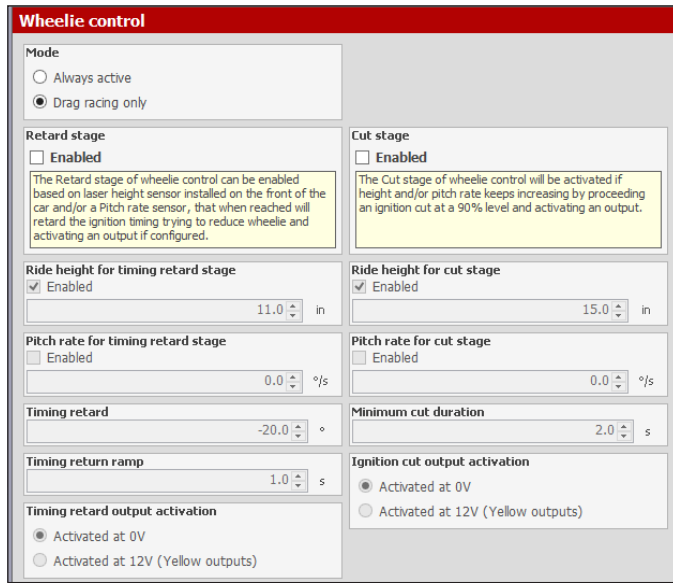

Cut stage

As the retarding control, there are height and pitch rate configurations to the cut stage. The cut level can be configured, and it is possible to define a minimum time to the cut occurs.

Always active: As long as the engine is running this feature will be active, independent how or where the car is positioned, even when testing the car in a car lift. This function is more recommended to motorcycles.

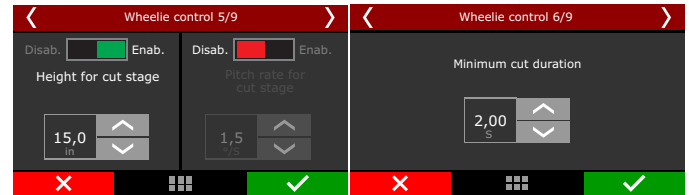

Drag racing only: This feature will be activated after releasing the 2 step button/switch, during the next 15s it will be operating.

Set height (in) or pitch rate (°/s) to activate the retard control. It is possible to use both sensors at the same time.

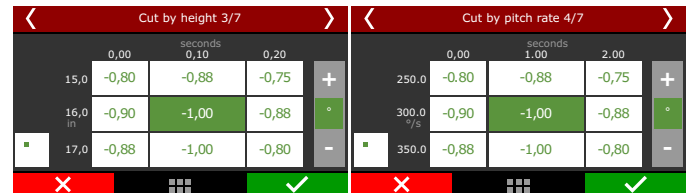

Retard Stage

This feature retards the ignition timing when the front of the car reaches the limit height configured. The cut stage cuts the ignition to control the front height of the vehicle.

The retard stage is a first try to keep the ride height under control, the cut stage is a more aggressive way to stops the height/or pitch rate of keep increasing.

Always active: As long as the engine is running this feature will be active, independent how or where the car is positioned, even when testing the car in a car lift. This function is more recommended to motorcycles.

There is also the option of trigger an auxiliary output when the retard or cut is being performed. The output can be used to release the chute, shift gear, etc.

In the FTManager, select the output in the “Sensors and calibration” menu, then “Outputs”.

To use this function, a height sensor or a pitch rate sensor must be installed and configured in the “Sensors and calibration” menu, then “Inputs”.

20.11 Davis Technologies

Davis Technologies Profiler is traction control module, for rear wheel drive cars, which controls ignition timing and ignition cut by driveshaft RPM. This function allows direct communication with FT600.

In the FTManager, go to “Sensor and calibration” menu, then “Inputs” and select the white wires that will do the communication with Davis Technologies Profiler.

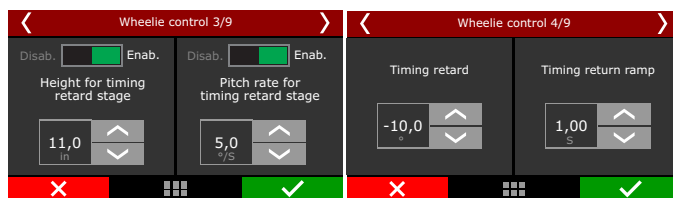

Drag racing only: This feature will be activated after releasing the 2 step button/switch, during the next 15s it will be operating.

Set height (in) or pitch rate (°/s) to activate the retard control. It is possible to use both sensors at the same time.

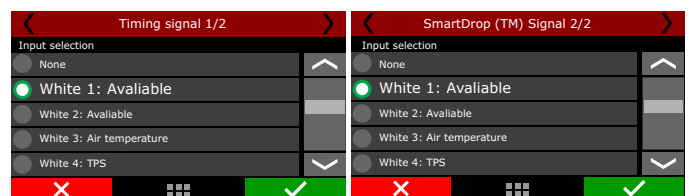
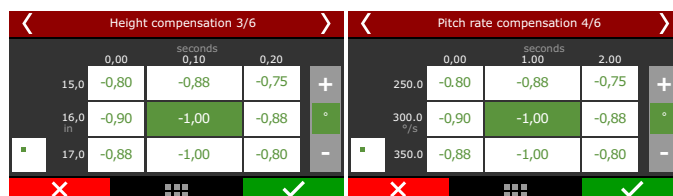

20.12 Staging control

This function helps the car alignment when pre-staging after the burnout.

When activated, it is possible to control the transbrake solenoid frequency to hold the car properly.

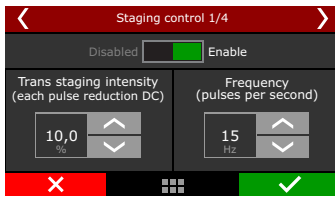

Select the desired inputs and outputs to use with this function.

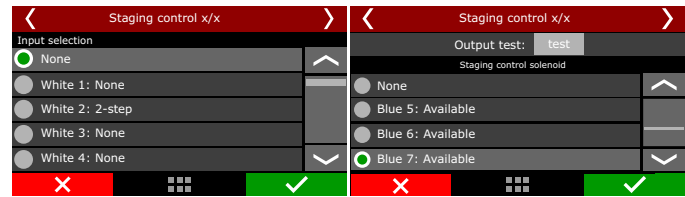

Set the button mode and the output activation voltage (by 0V or 12V).

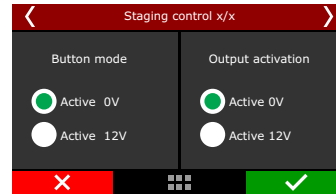

Staging control electrical diagram with Hella solid state relay

Use the diagram below to wire the staging control feature.

Any white wire can be used for the 2-step and staging buttons. The other side of the buttons must be connected to the battery negative or to a switched 12V when needed.



IMPORTANT:

The use of a solid state relay is mandatory for this feature to work properly.

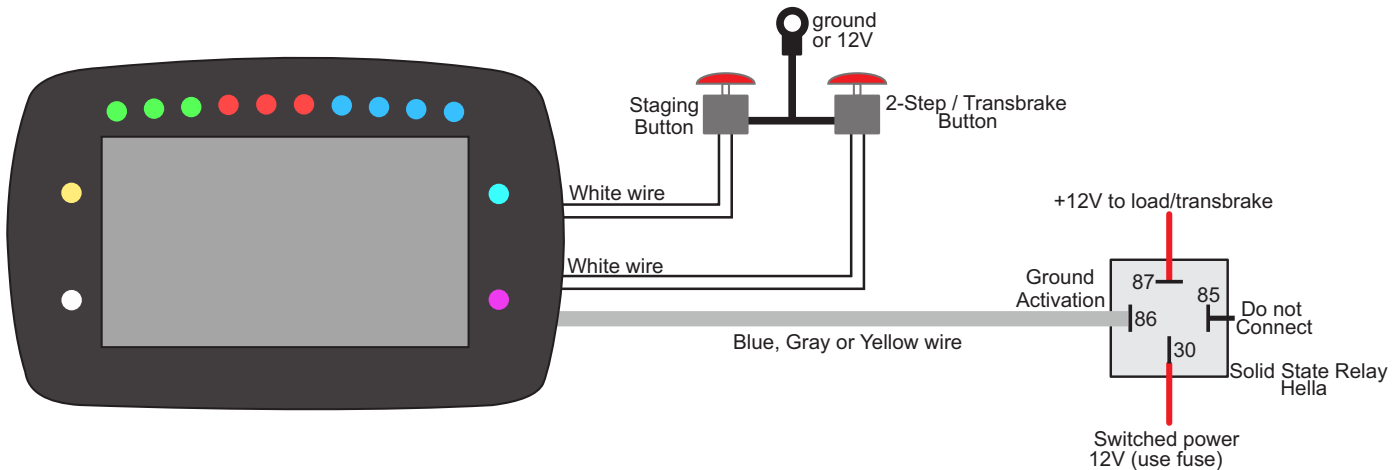

20.13 Time based throttle opening

This feature creates a curve for a time based progressive opening of the electronic throttle.

You can create a curve based on time by maximum percentage of throttle opening.

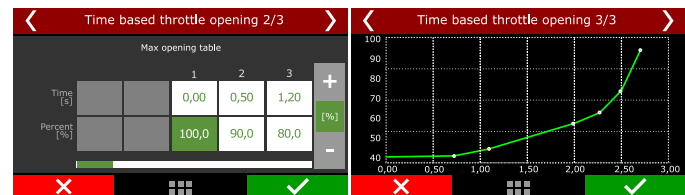

21. Alert settings

This is the menu where you can set all the alert warnings, including safety mode and engine shut down.

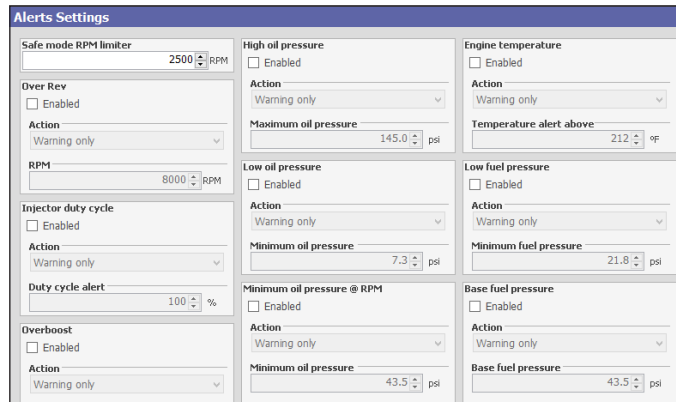

21.1 Safe mode RPM limiter

Safe mode protects the engine whenever an alert is activated, limiting max engine RPM while the alert condition is still happening.

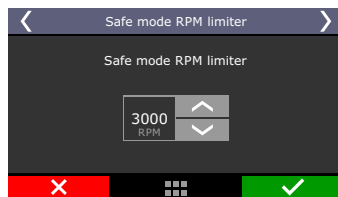

21.2 Alerts

The configuration of alerts allows the programming of sound and visual alerts whenever a dangerous situation to the engine is detected. It is possible to setup up to three different actions when any alert is displayed on the screen:

Alert only: alert is displayed on the screen, but the engine continues to work normally.

Safe mode: besides the alert displaying on the screen, engine has its max RPM limited to what was set up on the "Safe mode rev limiter" parameter

Engine shut off: besides the alert displayed on the screen, engine is immediately shut off by fuel and ignition cut.

Shift alert

When engine reaches the RPM set on this parameter, an alert can be shown at the dashboard and/or an auxiliary output can be activated to control an external shift light.

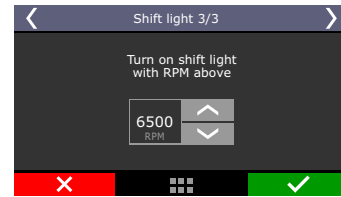
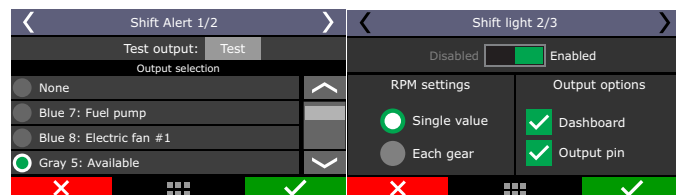

Over rev

Setup the RPM for alert and the action the ECU must perform.

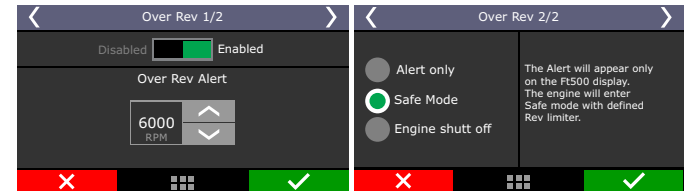

Overboost

Setup an overboost value to activate the alert and the action the ECU must perform.

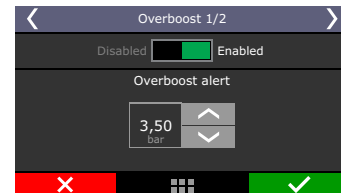

Engine temperature

Setup an engine temperature to activate the alert and the action the ECU must perform.

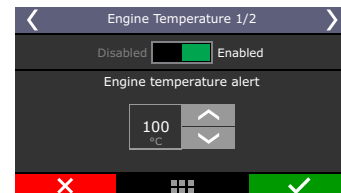

Injector duty cycle

Setup a percentage value that indicates injector's saturation.

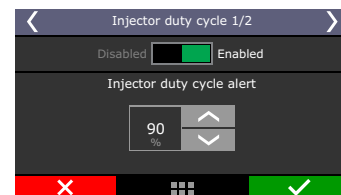

Oil Pressure

Setup a value that's considered as oil pressure excess and one that's considered for low oil pressure. Also, select how the ECU reacts when this alert is activated.

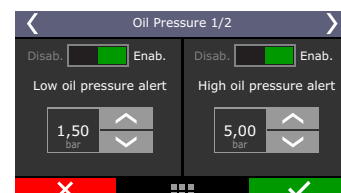

Minimum oil pressure

Setup a minimum oil pressure value above X RPM and how the ECU reacts.

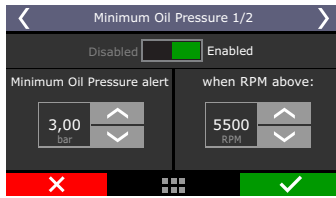

Low fuel pressure

Setup a value to activate the alert and how the ECU reacts.

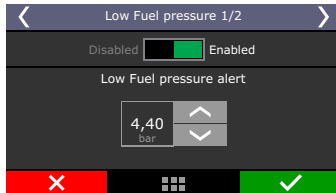

Base fuel pressure

Setup here a tolerance for the base fuel pressure.

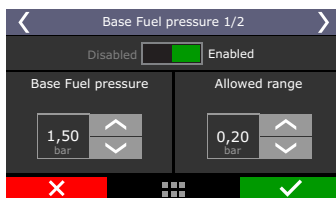

The base fuel pressure is what the pressure regulator should keep with MAP = 0 psi, that, in most of cases is 45psi with the engine turned off and the fuel pump turned on.

When engine is turned on, the vacuum/boost makes the fuel pressure regulator to manage the fuel pressure in a 1:1 ratio.

Example: an engine idling with -8.7psi of map pressure must have 34.8psi of fuel pressure if differential pressure is set as 43.5psi. If the MAP sensor is reading 29psi, the fuel pressure must be 72.5psi. If the tolerance range is 5.8psi, the differential pressure can vary from 37.7 psi to 49.3psi.

High exhaust gas temperature alert (EGT)

Set the high exhaust gas temperature value for alert and the alert type as: "Alert only" "Safe mode" or "Engine shut off".



NOTE:

This function only works for EGT probes reading a single cylinder. EGTs for the entire bank or a single EGT for the motor are not considered for this alert.

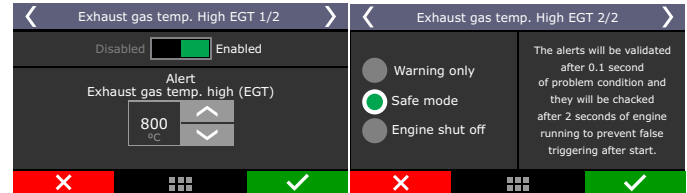

Low exhaust gas temperature alert (EGT)

Set the low exhaust gas temperature value for alert and the alert type as: "Alert only" "Safe mode" or "Engine shut off"



NOTE:

This function only works for EGT probes reading a single cylinder. EGTs for the entire bank or a single EGT for the motor are not considered for this alert.

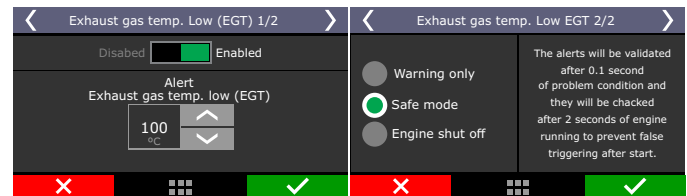

22. Favorites

In this menu it is possible to have access to the most used functions of the ECU. It gives quick access to functions as:

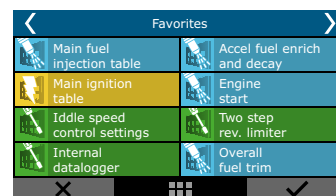

23. Interface settings

Here are the settings related to the interface like measure units, buzzer sound, LCD backlight, etc.

23.1 Day/night mode selection

There are 4 options to select.

Day mode: adjust brightness the display to value in LCD backlight settings menu.

Night mode: adjust brightness the display to value in LCD backlight settings menu.

Dashboard: Enable button on dash to control mode.

Day/night external switch: this option is necessary configure a white input with vehicle light switch.

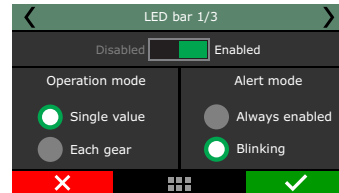

Single value: select the LED you want to edit, choose its color and the RPM value to activate it .

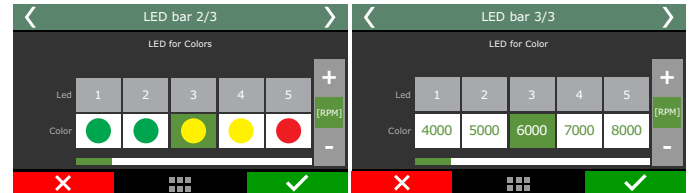

By gear: select the LED to edit, choose its color, set the RPM you want it to turn on for each gear and which LEDs will be activated.

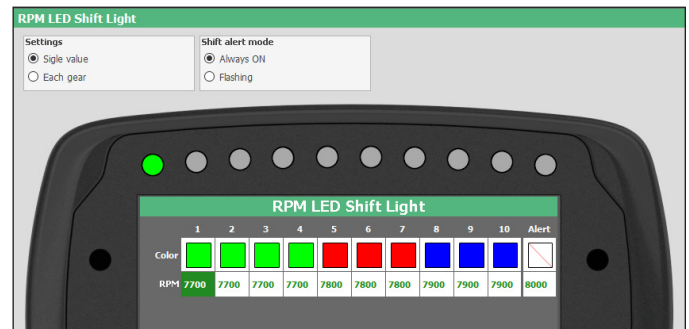
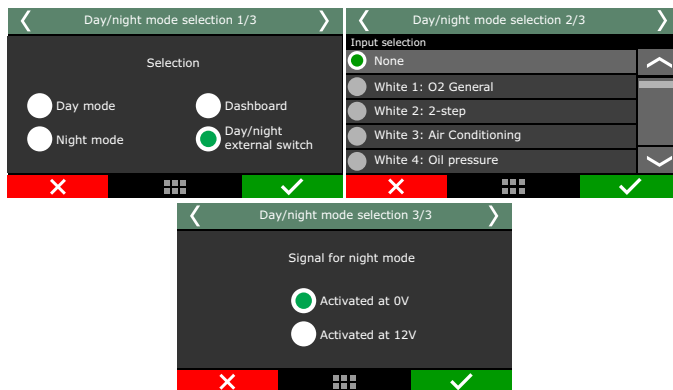
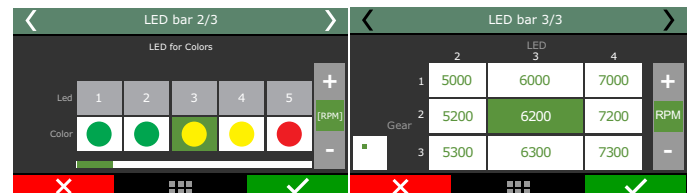

23.2 LCD backlight settings

Adjust LCD brightness and select between night and day modes.

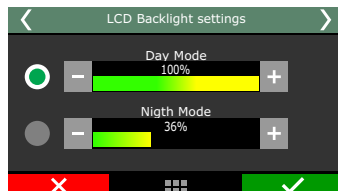

Side LEDs

It is possible to set side LEDs choosing from up to 52 alerts options.

23.3 LED configuration

This function is possible configure all options LED's

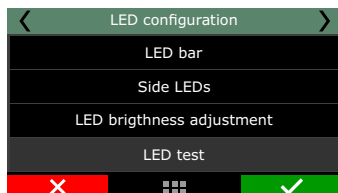

LED bar

Select here the options on how the shift light LEDs will work. It is possible to set the LEDs to turn on in a fixed RPM, progressively or with different values by gear.

Color: Select the LED color.

Warning mode: This menu has two options; always enabled or blinking;

Condition: Select the function will be associated to this LED.

Activation mode: set the maximum and minimum values to turn the LED on.

Operation 2 and 3: This option provides more activation conditions to the same LED.

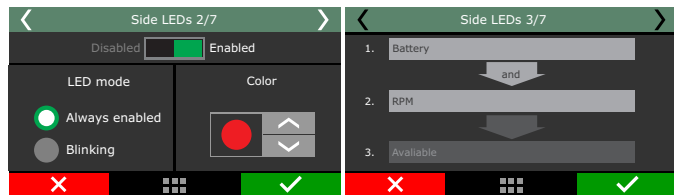
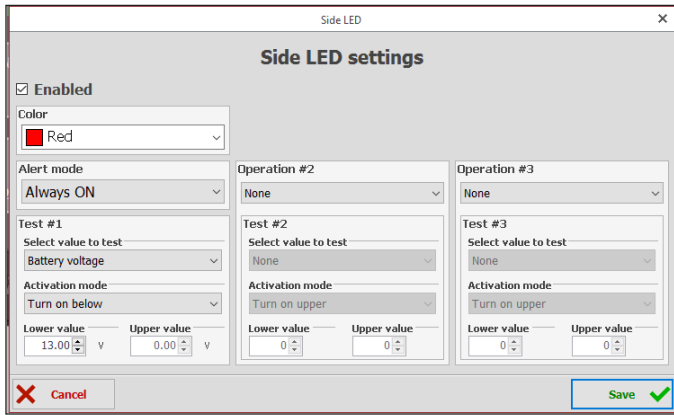

LCD backlight settings

Adjust LCD brightness side LED's and select between night and day modes.

LEDs Testing

This option verify if all LEDs are working properly. Selecting this function the LEDs must to turn on with the same color and at the same time, in case any LED do not turn on you must get in contact with FuelTech maintenance sector.

23.4 Alert sound settings

This parameter allows for setting the volume of sounds generated by touching the display. When the mute option is selected, the ECU is silent when the screen is touched.

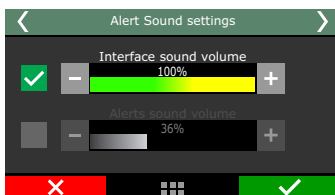

23.5 Dashboard setup

There are 96 configurable positions on the dashboard, with minimal size of 1x1. It's possible to select sizes as 1x2, 2x1, 2x2, 3x2 and 3x1. First, select the position where you want the information to be, then the reading that will be displayed and the reading size.

Dashboard setup is very simple, first select the number of dashboards you want (1 to 4), after that set the space will be used, and then, choose the information you want and select right to define the gauge size.

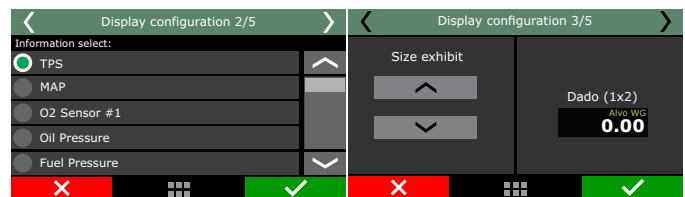
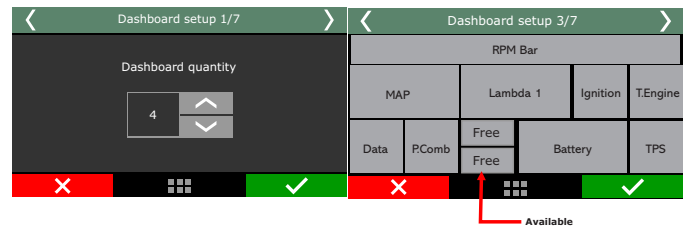

NOTE: After version 3.10 of FTManager is possible to set 4 different dashboards directly in the software clicking over the free gauges and editing the informations.

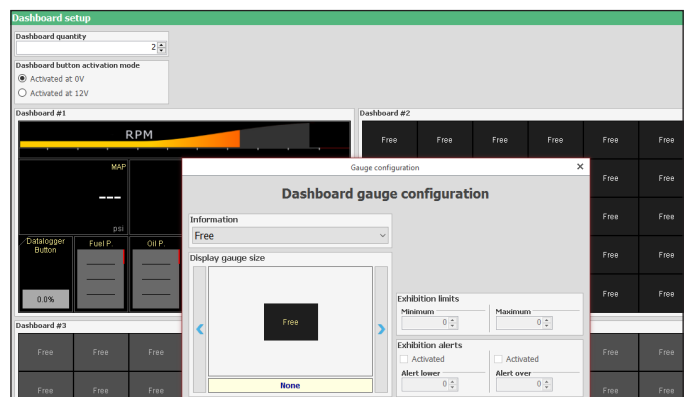
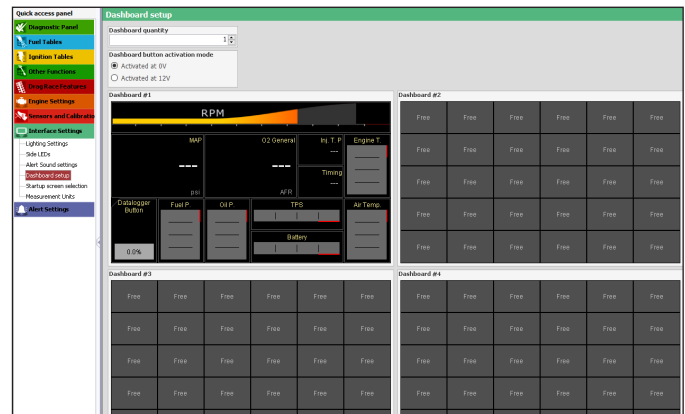

Clicking in the superior corners of the touchscreen the other configured dashboards will appear, as illustrated below, or set a white input as a button/switch key to change the dashboards.

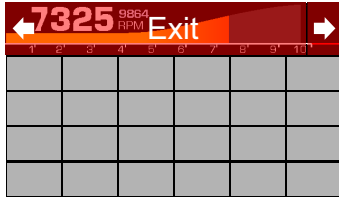

Exhibition limits and alerts

On some sensors, maximum and minimum values may be set up to activate alerts on the dashboard. In this case, the sensor changes his color to indicate something is wrong. The readings with this options are: MAP, air temperature, engine temperature, battery voltage, fuel pressure, oil pressure, TPS, dwell, ignition timing, primary injection time, secondary injection time, O2 sensor 1, O2 sensor 2 and delta TPS

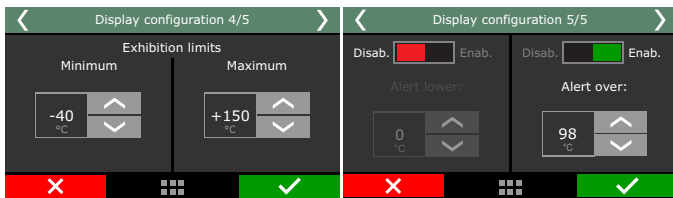

RPM bar

When clicking the RPM bar parameter, it is possible to setup the RPM where the red zone starts.

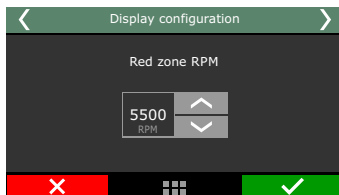

23.6 Startup screen selection

Select the screen shown right after the ECU is turned on. In case the option "Open the main menu after startup" is selected and the ECU is set up with a user password, the ECU will ask for the user password.

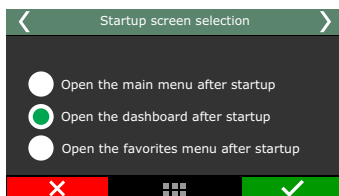

23.7 Password Protection setup

It is possible to set 2 different kinds of password:

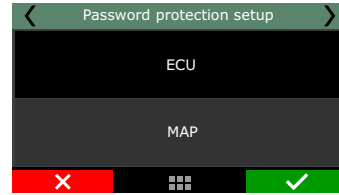
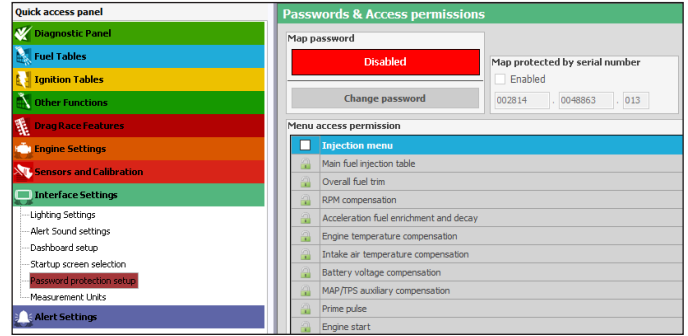

ECU Password

Activating the ECU password allows three types of blocking protection:

- **FTManager:** choose this option to activate an FTManager access password, but keep all touchscreen menus accessible. Do this to avoid that a password be activated without your consent.
- **Menus:** This option protects all the ECU menus, only giving access to information displayed on the on board computer and engine status.
- **Engine Start:** Engine start blocking. All menus will be available for viewing and editing, but the ECU system will be blocked until the password is inserted.

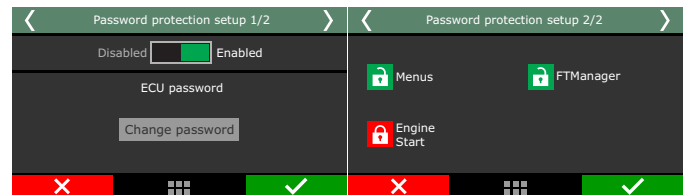

Map Password

This password blocks all the map menus of the fuel and ignition table adjust, engine settings, aux function and file manager. Alert settings, shift alert, display and initial screen are left unprotected. When this password is enabled, it's not possible to change any ignition or fuel map.

The FTManager software access is also blocked by the Map password.



WARNING:

Passwords come disabled by default, when you enable a password you will be blocking access to people using the ECU, even yourself. When you choose a password, be sure you will remember it, as for safety reasons this password will only be removed through the total reset of the ECU (all maps and data are erased).

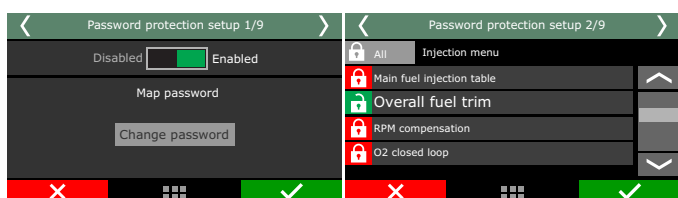

23.8 Clear peaks

At the Dashboard, values read by the sensors connected to the module are displayed in real time. On the bottom of each box on the display, the minimum (on the left) and maximum (on the right) values read by the sensor are shown.

It is possible to clear this data by accessing the option "Clear Peaks", under the "Interface Settings" menu.

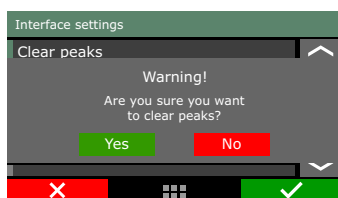

23.9 Measurement units

In this menu it is possible to change the measurement unit for some parameters as pressure, temperature, speed and O2 readings.

Pressure Units: bar, PSI or kPa;

Temperature units: °C or °F;

O2 sensor units: Lambda, AFR Gasoline or AFR Methanol;

Speed units: km/h or mph

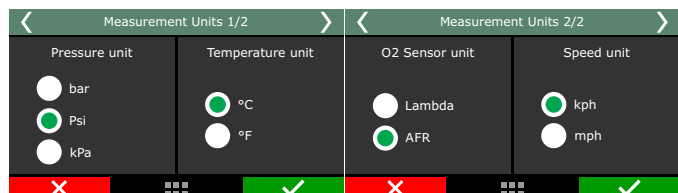

23.10 Demonstration mode

The demonstration mode can be enabled to show the main features of FuelTech FT600 and its working. You can set the waiting time to get in the demo mode. To exit, just touch the screen.

23.11 Touchscreen calibration

This function allows the touchscreen recalibration, use it whenever you notice the screen is unresponsive. Calibrate the screen with you finger or with a pen.

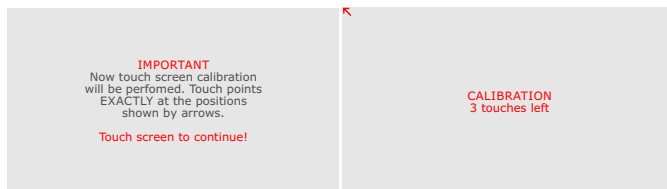

23.12 Serial number and software version

In this menu, it is possible to verify the software version and the equipment's serial number.

Make sure you have these numbers in hand whenever the FuelTech Technical Support is contacted to facilitate and optimize the assistance.

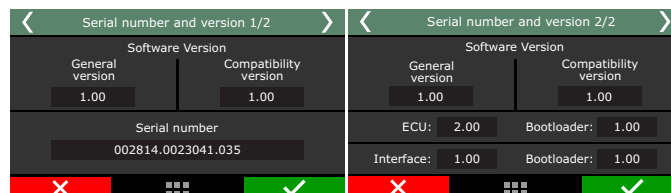

24. File manager

With the file manager it is possible to alternate between the 5 memories positions stored in the ECU. With this, you can have up to 5 totally different calibrations for different fuels or engines. Other option is to use the same ECU for up to 5 different engines with its own maps.

In the FTManager, the functions of File Manager are available in the tool bar.

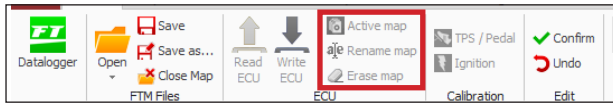
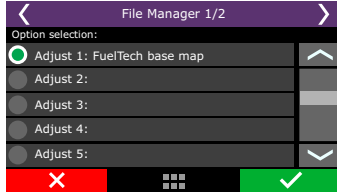

24.1 FuelTech base map generator

This function generates a base map that can be used to start engine tuning. It is very helpful cause gather information from the “Engine setup” menu to create a base map more accurate to the engine needs.

Before using this function, make sure you have followed chapter 5 in this guide.

Further information about the assistant manager can be found in the Chapter 7.7 of this manual

24.2 Edit map file name

Edit the file map name after generating the FuelTech base map.



24.3 Copy map to another file

This option copies a map that is already setup, to an empty position or to overwrite a previous map. First, select the map that will be copied, click right, then select the option “Copy map to another file”. On the next screen, map that will be copied is not shown, only the positions available to be overwritten.

In the example below, the Adjust 4 was copied to Adjust 1, which was empty:

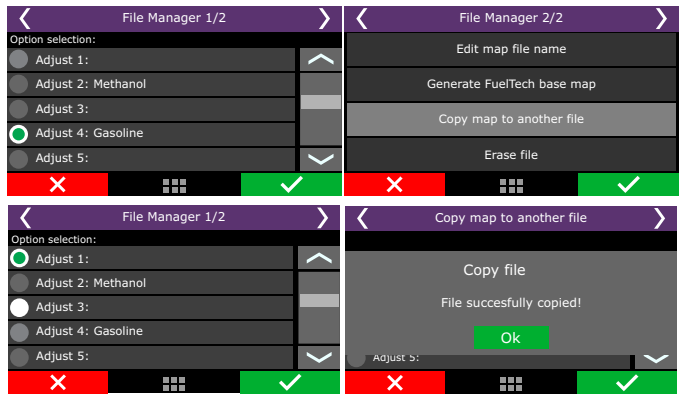

24.4 Erase file

Map files that will no longer be used can be easily erased with this option. To erase a file, simply enter on in by clicking right, then select option “Erase file”. After the confirmation, every parameter that was previously changed will be erased to factory default.

25. Rotary engines setup

The crank angle sensor (CAS) has two (2) trigger wheels that provide different signals to the ECU. As shown in picture, the bottom wheel is a 24 teeth trigger that provides the RPM signal and position of the eccentric shaft. The top wheel is a 2 teeth trigger that provides information of the position of the rotor.

FuelTech ECU will control the ignition timing using the reference of the 24 tooth wheel to spark the leading coil. All ignition timing programmed in the tables is referenced to the leading coil. Trailing coil will be fired using the programmed timing split parameter. This means that if the ignition timing in the main table is 0° and timing split is 10°, the ECU will fire the leading coil at 0° and the trailing coil 10° after leading coil was fired. The timing split parameter is fixed across all the ignition timing range.

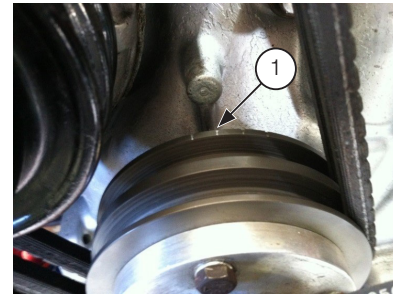

- Align the Crank Angle Sensor to 0° using the mark in the shaft.

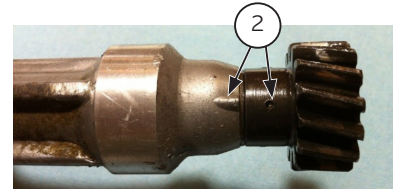

- Install and tighten the Crank Angle Sensor in the engine. After the steps above are correctly followed, the Crank Angle Sensor should be aligned at TDC with the eccentric shaft.

25.2 Crank angle sensor wiring

The stock distributor will be read by FT as a Crank Angle Sensor and Camshaft Position Sensor. Here's how to connect the FT to your stock Mazda distributor:

25.1 Crank angle sensor installation and alignment

The Crank Angle Sensor needs to be installed in the engine at 0° (top dead center position). To align it, follow this quick step by step:

- Use your ignition timing marks in the damper to align the eccentric to TDC. The ignition timing mark to be used is shown below.

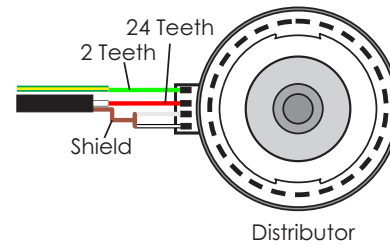

Function	Distributor wire	FuelTech wire	FuelTech pin
24 teeth signal (crank signal)	Red	Red from black shielded cable	1
24 teeth sensor negative	White	White from black shielded cable	2
2 teeth signal (home)	Green	Red from gray shielded cable	3
2 teeth sensor negative	White/Black	White from gray shielded cable	4

For engines using trigger wheel instead of distributor, here are the connections:

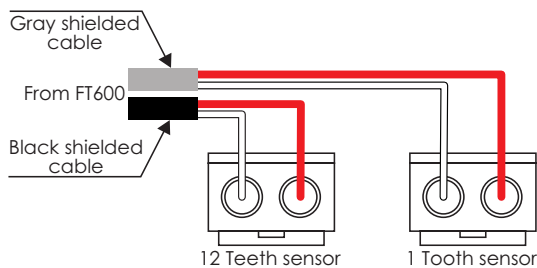

- A - White from black shielded cable (crank trigger white wire)
- B - Red from black shielded cable (crank trigger red wire)
- C - White from gray shielded cable (Cam sync white wire)
- D - Red from gray shielded cable (Cam sync red wire)

Function	FuelTech wire	FuelTech pin
12 teeth sensor (crank signal)	Red from black shielded cable	1
12 teeth sensor negative	White from black shielded cable	2
1 tooth sensor (home signal)	Red from gray shielded cable	3
1 tooth sensor negative	White from gray shielded cable	4

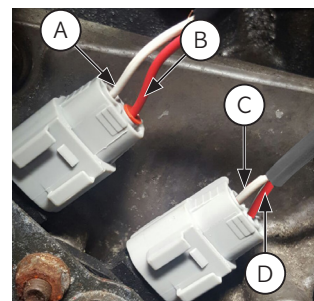

25.3 ECU setup

First, go to Fuel Injection Setup and enter the following:

- Max RPM: setup according to your engine;
- Injection mode: setup according to your engine;
- Idle by: TPS (fixed injection time on idle), MAP (injection time by MAP readings);
- Engine type: Rotary;
- Max boost pressure: setup according to your engine;
- Injectors banks: FT has two banks, setup how you want to use them (both as primary or A as primary and B as secondary);
- Acceleration fuel enrich: use by TPS, it's more accurate;

- Number of cylinders/rotors: setup according to your engine;
- Fuel injectors deadtime: if you don't have this info about your injectors, use 1,00ms;

Now, go to Ignition Setup and select:

- Ignition: Crank/Cam Ref. w/ Multi Coils;
- Crank Trigger Pattern: select option "12 (at crank) 24 (at cam)";
- First Tooth Alignment: 0 teeth or 5° BTDC;
- Crank Ref Sensor: VR differential;
- Crank Ref Edge: Falling edge;
- Cam sync position angle: 23° BTDC;
- Cam Sync Sensor: VR differential (FT600);
- Cam Sync Polarity: Falling edge;

Ignition output edge

Ignition system	ECU ignition output edge
Spark Pro	Falling dwell (Inductive / SparkPRO)
MSD DIS-2 (1)	Rising duty (CDI)
MW Pro-14/R(2)	Falling dwell (Inductive / SparkPRO)
MW-Pro Drag 4/R(3)	Falling dwell (Inductive / SparkPRO)

Notes:

1. Use two (2) ignition units
2. Considering that MW PRO-14/R trigger edge need to be configured as Falling Dwell leaving pins 9 to 10 unconnected. See page 9 of MW Ignition manual for more details
3. There is no set up the trigger edge of Pro-Drag 4/R. Trigger edge is Falling Dwell by default.

After setting up Fuel Injection Setup and Ignition Setup menus, make sure you go through chapter 11.3 to generate a fuel and timing base map for your engine.

25.4 Ignition coils wiring

After setting everything up, the ignition outputs of the ECU are ready to be connected to your coils or ignition modules. FT ECU ignition outputs cannot be connected directly to dumb coils, only to smart coils (coils with integrated ignition module) or ignition modules.

For 2 rotor engines, the gray wires are connected as the table below shows:

ECU ignition output	Function	Recommended SparkPRO-4 channel
Gray wire #1	Leading rotor #1 – Coil L1	Channel 1
Gray wire #2	Leading rotor #2 – Coil L2	Channel 2
Gray wire #3	Trailing rotor #1 – Coil T1	Channel 3
Gray wire #4	Trailing rotor #2 – Coil T2	Channel 4

For 3 rotor engines, the gray wires are connected as the table below shows:

ECU ignition output	Function	Recommended SparkPRO-6 channel
Gray wire #1	Leading rotor #1 – Coil L1	Channel 1
Gray wire #2	Leading rotor #2 – Coil L2	Channel 2
Gray wire #3	Leading rotor #3 – Coil L3	Channel 3
Gray wire #4	Trailing rotor #1 – Coil T1	Channel 4
Gray wire #5	Trailing rotor #2 – Coil T2	Channel 5
Gray wire #6	Trailing rotor #3 – Coil T3	Channel 6

26. FT600 – electrical diagram

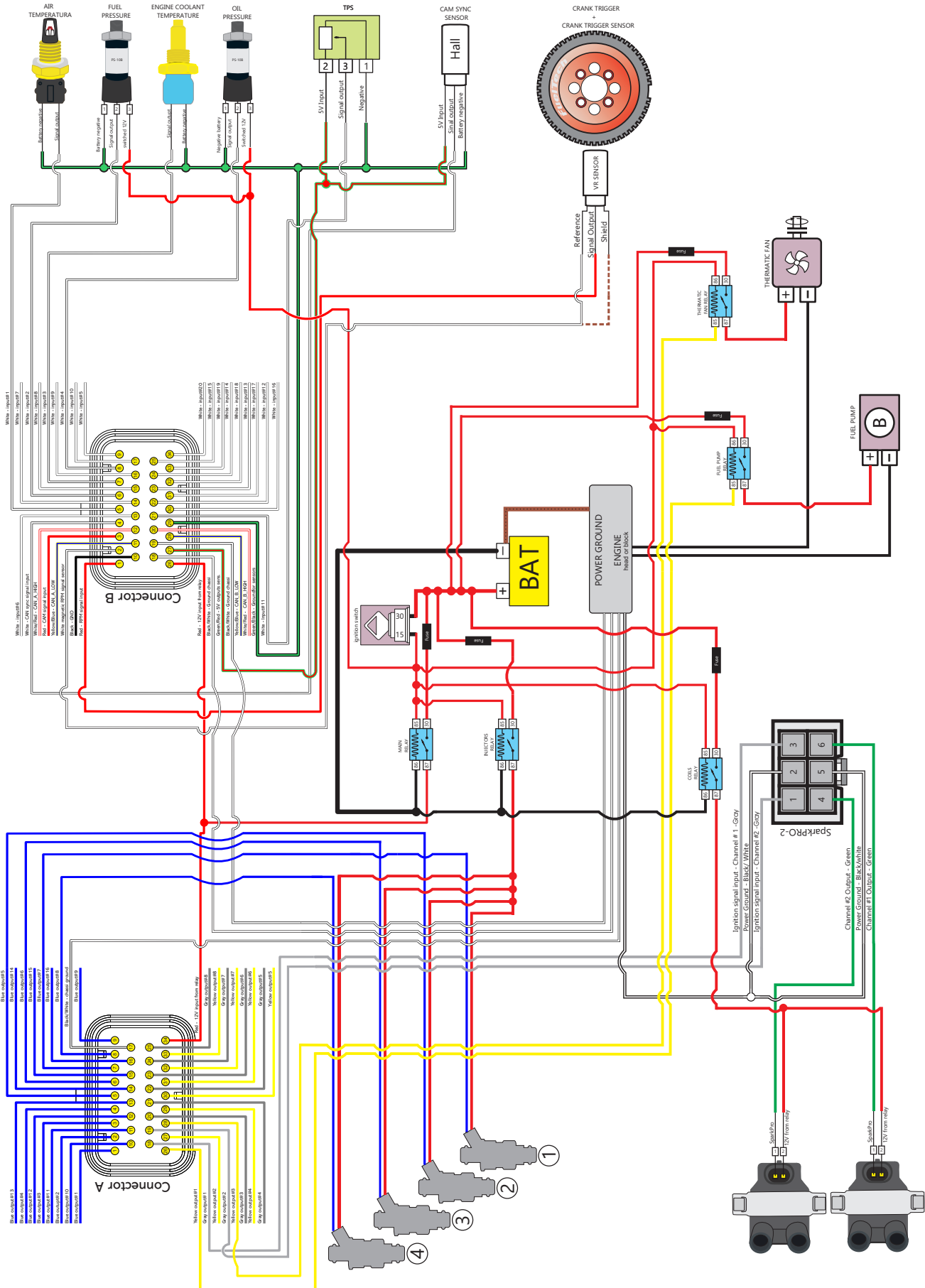



FuelTech

Fixing Template | Gabarito de Fixação | Plantilla de Fijación

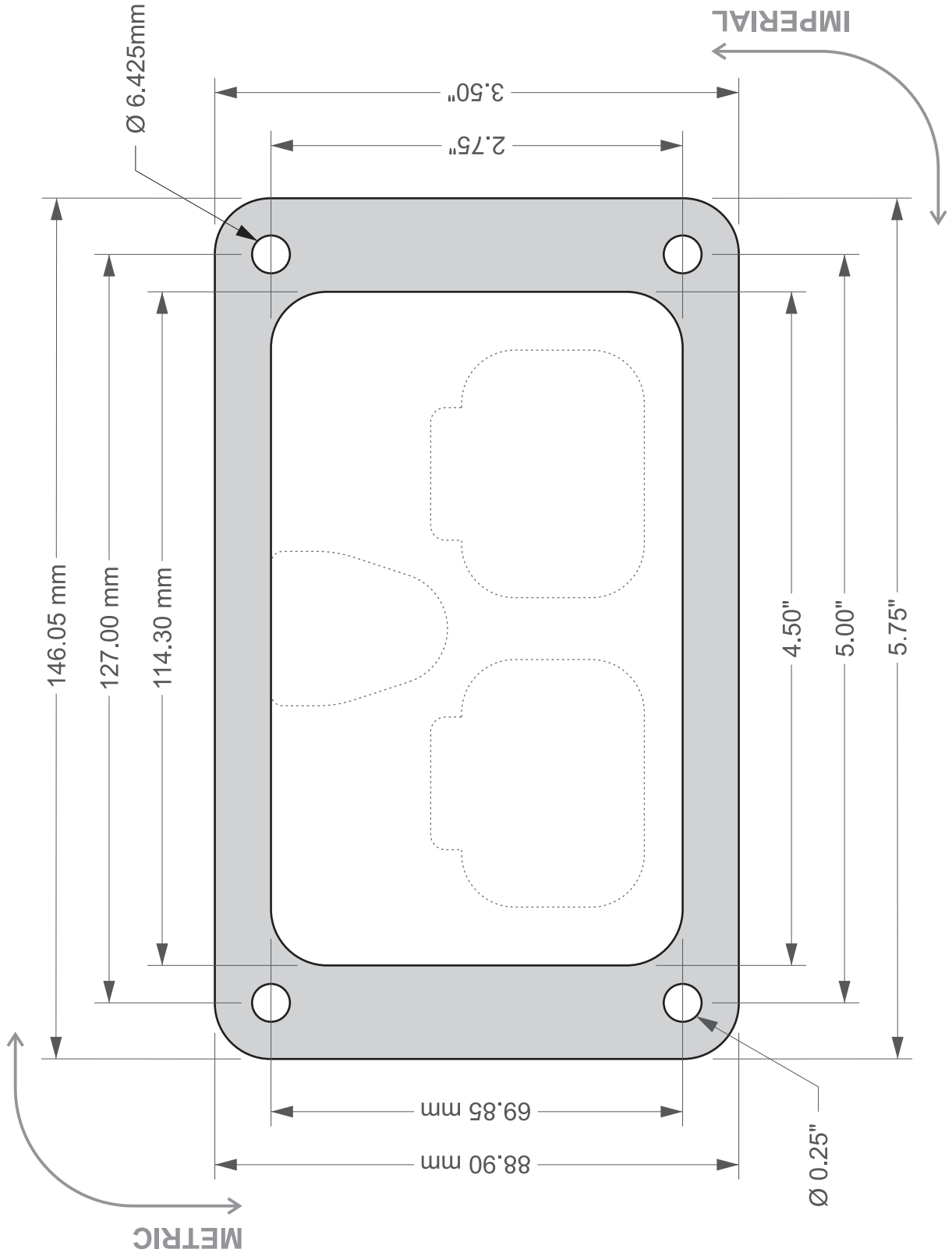

FuelTech

455 Wilbanks Dr.
Ball Ground, GA, 30107, USA

Phone: +1 678-493-3835
Toll Free: +1 855-595-3835

E-mail: info@FuelTech.net
www.FuelTech.net

 FuelTechUSA

POWER **FT**
ECU |