

Key Clamp

| Revision # | Revision Date |
|------------|---------------|
| # 0 | 18/01/2023 |
| | |
| | |



Lockinex Key Clamps are malleable iron castings, streamlined in appearance and providing considerable versatility in their application. Used with Lockinex Tubing, they create robust and durable installations, which are aesthetically pleasing. A wide range of rigid modular structures are possible with standard clamps. They are easily and quickly assembled without the need of special skills or tools.

Lockinex UK Ltd manufacture their own brand of key clamp which are manufactured to relevant British standards with malleable cast iron fittings to BS EN 1562:2012 and hot dip galvanising to BS EN ISO 1461:2009, so you can be sure to receive a quality product. Handrail tube is manufactured to BS EN 10255:2004 and galvanised to BS EN 10240:1998.

Lockinex Key Clamps are available in a wide range of configurations, fitting five different diameters of tubing. The diversity allows the construction of Guardrails, Handrails, Storage & Racking, Machine Guards & much more.

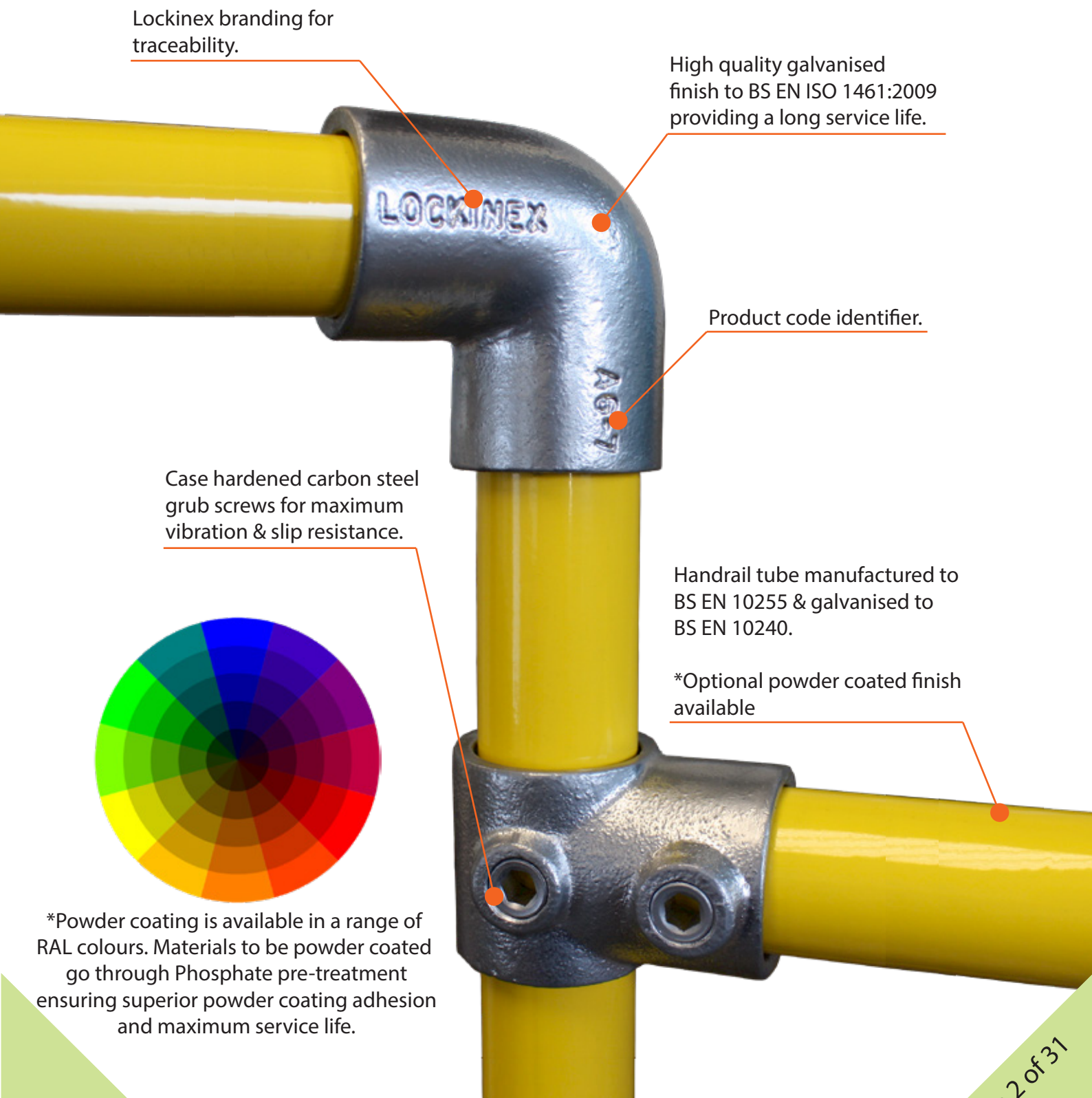

Lockinex branding for traceability.

High quality galvanised finish to BS EN ISO 1461:2009 providing a long service life.

Product code identifier.

Case hardened carbon steel grub screws for maximum vibration & slip resistance.

Handrail tube manufactured to BS EN 10255 & galvanised to BS EN 10240.

*Optional powder coated finish available



*Powder coating is available in a range of RAL colours. Materials to be powder coated go through Phosphate pre-treatment ensuring superior powder coating adhesion and maximum service life.

Handrail infill panels

We stock a range of hot dip galvanised mesh infill panels for use with our 48.3mm key clamp handrail system. All panels are designed to be used with upright post centres at 1495mm to achieve 0.36kN/m general duty loading with 1100mm approx. finish height.

| Code | Guardrail infill panels from stock |
|--------------|---|
| MSH-1363X418 | 1363x418mm, 50x50x3mm mesh, 8mm rod frame, galvanised finish. |
| MSH-1363x836 | 1363x836mm, 50x50x3mm mesh, 8mm rod frame, galvanised finish. |
| MSH-1363x972 | 1363x972mm, 50x50x3mm mesh, 8mm rod frame, galvanised finish. |



PGKC-900-8 (48.3mm)
PGKC-1200-8 (48.3mm)

1000mm tall, 900mm wide infill panel
1000mm tall, 1200mm wide infill panel

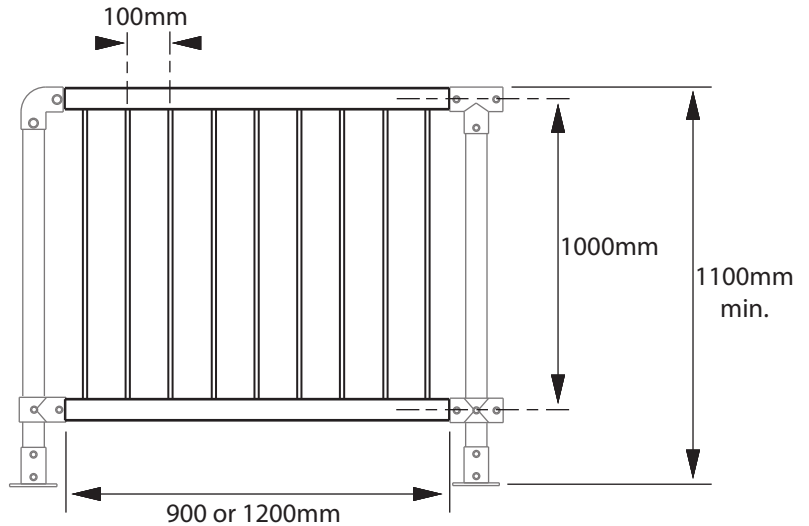

Fencing infill panels used in conjunction with Lockinex key clamps and PGKC ready made key clamp kits. Standard infill panels can be easily cut down to suit site conditions and have a hot dip galv. finish. Posts shown in drawing are not included. Powder coating to your choice of RAL colour available.

PGKC-Corner-8 (48.3mm)



Ready made corner post ready to accept PGKC infill panels. Utilises the Lockinex key clamp range. 48.3mm dia. post.

PGKC-Middle-8 (48.3mm)



Ready made middle post ready to accept PGKC infill panels. Utilises the Lockinex key clamp range. 48.3mm dia. post.

PGKC-End-8 (48.3mm)



Ready made end post ready to accept PGKC infill panels. Utilises the Lockinex key clamp range. 48.3mm dia. post.

Galvanised shown - Powder Coated also available.

All measurements in (mm)

Ready made key clamp

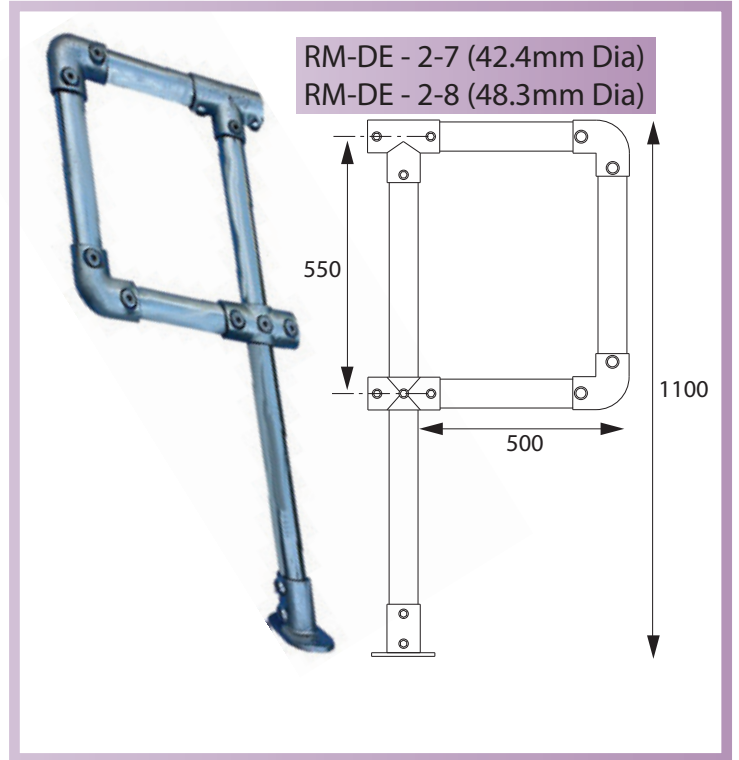
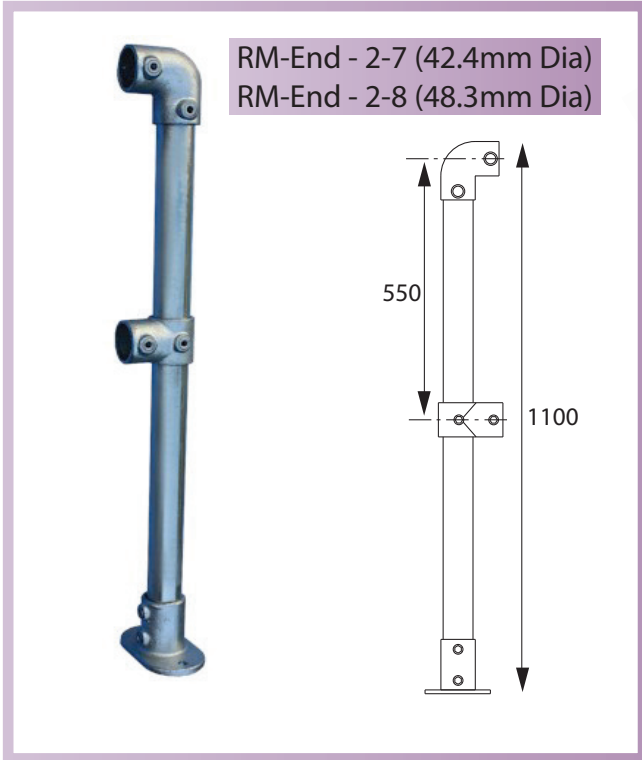

Galvanised shown - Powder Coated also available.

All measurements in (mm)

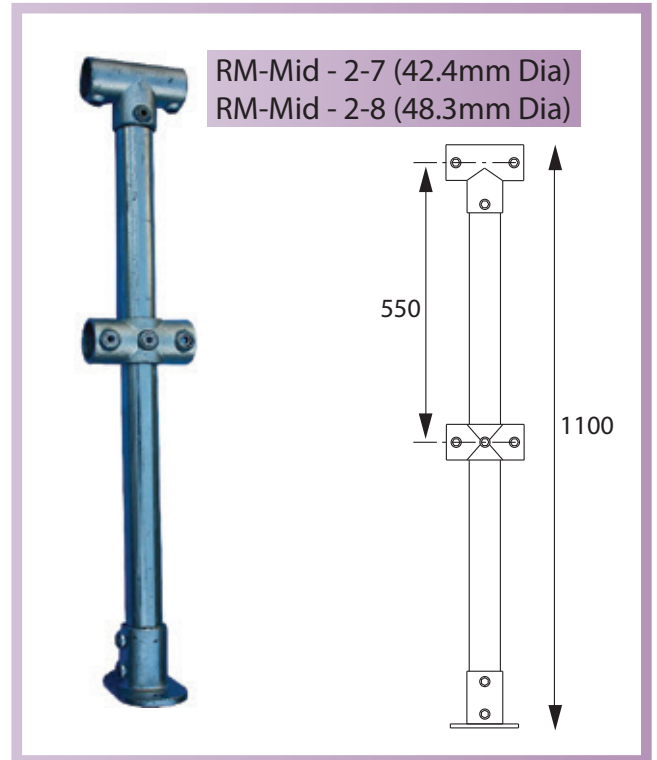
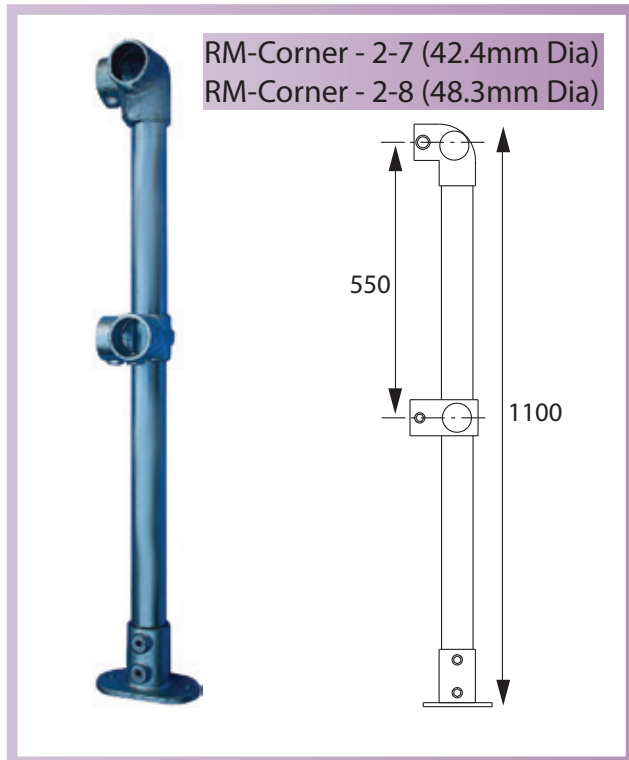

Galvanised shown - Powder Coated also available.

Galvanised Tube

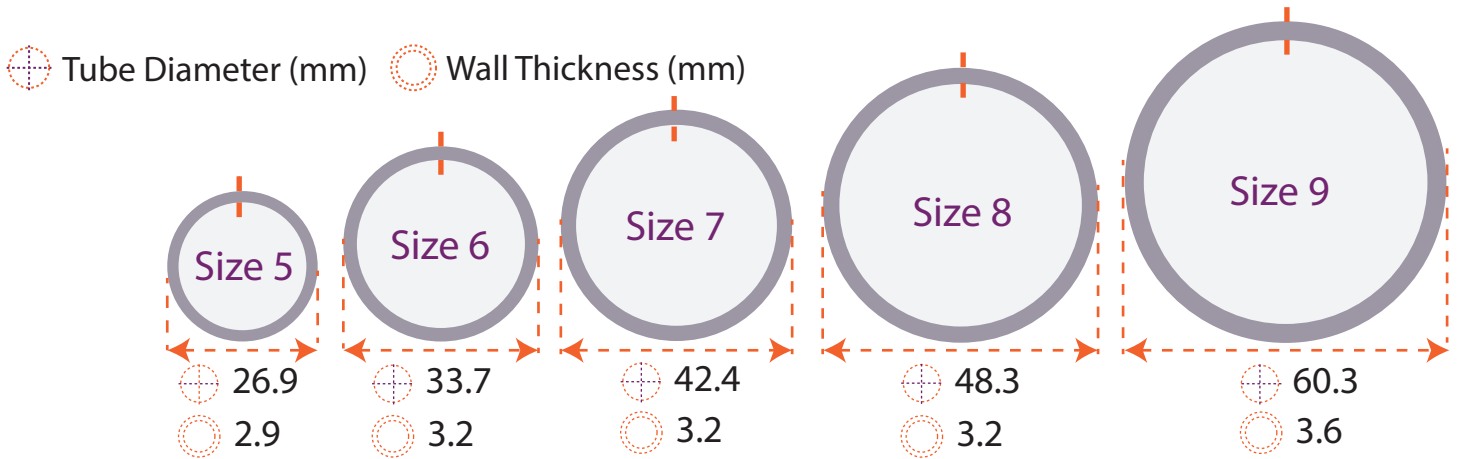

Lengths

3.2mtr

6.0/6.4mtr



A01

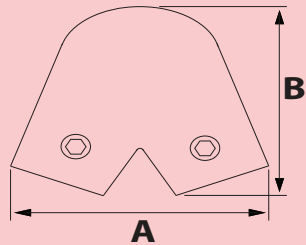

| Tube size | A | B |
|-------------------|-----|-----|
| 8 (D)=48.3mm dia. | 160 | 125 |

| A | B |
|---|---|
| - | - |
| - | - |
| - | - |
| - | - |
| - | - |

Two tubes can be joined to create an incline of 11-30 degrees . Joins the angled rail from a ramp or steps to a vertical post on a landing. Starts an angled rail from top of a first post.



A02

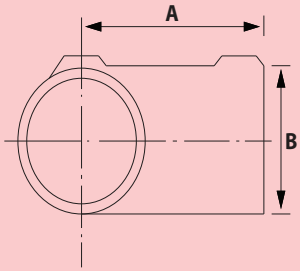

| Tube size | A | B | C | D | E | F |
|--------------------|----|----|---|---|---|---|
| 5 (A)=26.9mm dia. | 44 | 36 | - | - | - | - |
| 6 (B)=33.7mm dia. | 48 | 44 | - | - | - | - |
| 7 (C)=42.4mm dia. | 60 | 54 | - | - | - | - |
| 8 (D)=48.3mm dia. | 68 | 64 | - | - | - | - |
| 9 (E)= 60.3mm dia. | 85 | 75 | - | - | - | - |

| A | B | C | D | E | F |
|---|---|---|---|---|---|
| - | - | - | - | - | - |
| - | - | - | - | - | - |
| - | - | - | - | - | - |
| - | - | - | - | - | - |
| - | - | - | - | - | - |

Provides 90 'T' connection between two tubes. Used for the joint between an end post and lower rail(s) when handrail is straight and level. Also for a top 'T' joint on a guardrail. Cannot join tube in top of 'T', use A4 when this is required.



A02R (Retro fit)

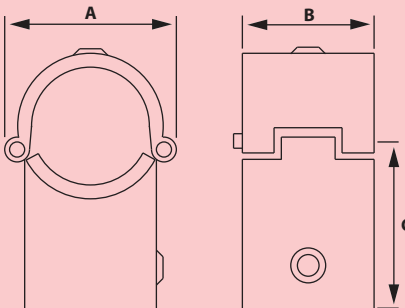

| Tube size | A | B | C |
|-------------------|----|----|----|
| 7 (C)=42.4mm dia. | 76 | 56 | 60 |
| 8 (D)=48.3mm dia. | 83 | 62 | 70 |

| A | B | C |
|---|---|---|
| - | - | - |
| - | - | - |
| - | - | - |
| - | - | - |
| - | - | - |

Provides the same function as the A02. However, this clamp can be retro fitted to an existing installation so disassembly is not required. The clamp can be split in half by removal of the pins and fitted to the existing structure.



A03

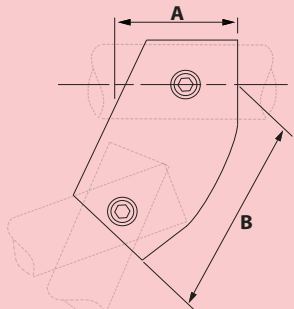

| Tube size | A | B | C | D | E | F |
|-------------------|----|-----|---|---|---|---|
| 6 (B)=33.7mm dia. | 54 | 74 | - | - | - | - |
| 7 (C)=42.4mm dia. | 64 | 89 | - | - | - | - |
| 8 (D)=48.3mm dia. | 68 | 102 | - | - | - | - |

| A | B | C | D | E | F |
|---|---|---|---|---|---|
| - | - | - | - | - | - |
| - | - | - | - | - | - |
| - | - | - | - | - | - |

Variable angle clamp, tubes can be connected between angles of 30 to 60 degrees. Use for an angled top rail joint to vertical post on stairs. Used in conjunction with A23 for the lower rail(s). Can be used for diagonal braces for racking etc.



A04

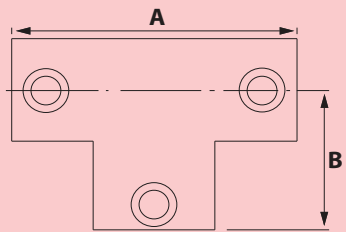

| Tube size | A | B | C | D | E | F |
|--------------------|-----|----|---|---|---|---|
| 5 (A)=26.9mm dia. | 88 | 44 | - | - | - | - |
| 6 (B)=33.7mm dia. | 96 | 48 | - | - | - | - |
| 7 (C)=42.4mm dia. | 120 | 60 | - | - | - | - |
| 8 (D)=48.3mm dia. | 136 | 68 | - | - | - | - |
| 9 (E)= 60.3mm dia. | 170 | 90 | - | - | - | - |

Provides a 90 degree 'T' connection between two tubes. Used for the joint between a top rail and a vertical post. Allows tubes to be joined in the top part of the 'T'. When used in guardrailing the A22 will compliment this for lower rail(s).



A05

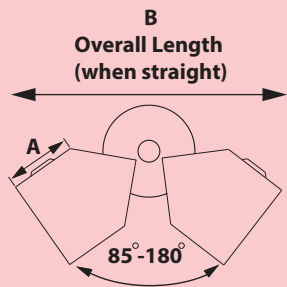

| Tube size | A | B |
|-------------------|----|-----|
| 7 (C)=42.4mm dia. | 40 | 65 |
| 8 (D)=48.3mm dia. | 45 | 170 |

Allows angles between 85 -180 . Used to change direction of rails in the same plane. Consider the A07 as an alternative.



A06

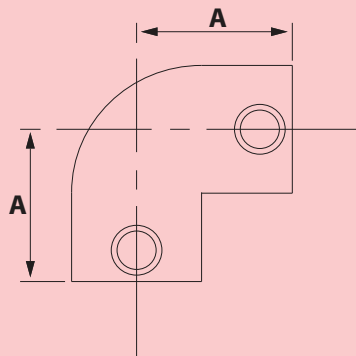

| Tube size | A | B | C | D | E | F |
|--------------------|----|---|---|---|---|---|
| 5 (A)=26.9mm dia. | 44 | - | - | - | - | - |
| 6 (B)=33.7mm dia. | 48 | - | - | - | - | - |
| 7 (C)=42.4mm dia. | 60 | - | - | - | - | - |
| 8 (D)=48.3mm dia. | 68 | - | - | - | - | - |
| 9 (E)= 60.3mm dia. | 85 | - | - | - | - | - |

This is a 90 elbow joint. Used frequently for the termination of the top rail to the last post of a handrail. Also used for turning the rails around a 90 corner.

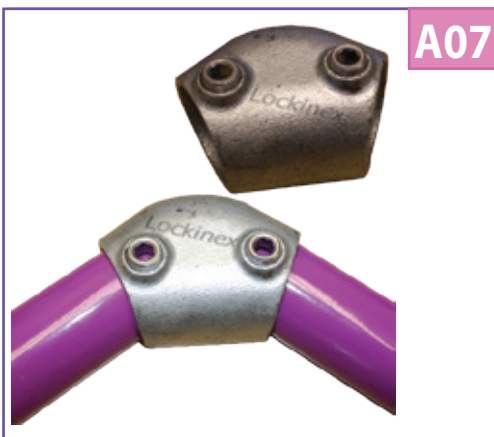

A07

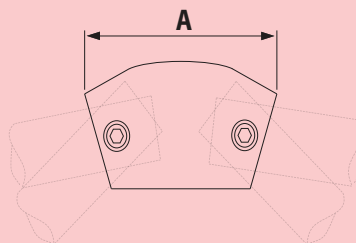

| Tube size | A | B | C | D | E | F |
|-------------------|-----|---|---|---|---|---|
| 6 (B)=33.7mm dia. | 90 | - | - | - | - | - |
| 7 (C)=42.4mm dia. | 106 | - | - | - | - | - |
| 8 (D)=48.3mm dia. | 120 | - | - | - | - | - |

Two tubes can be joined with an angle range between 15 - 60 degrees. Joins the angled rail from a ramp or steps to level rails on a landing. Starts an angled rail from top of a first post. Can be used for obtuse angle change in a handrail.



A08

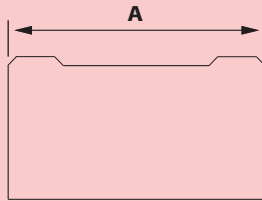

| Tube size | 5 (A)=26.9mm dia. | 6 (B)=33.7mm dia. | 7 (C)=42.4mm dia. | 8 (D)=48.3mm dia. | 9 (E)= 60.3mm dia. |
|-----------|-------------------|-------------------|-------------------|-------------------|--------------------|
| A | 64 | 90 | 96 | 96 | 125 |
| B | - | - | - | - | - |
| C | - | - | - | - | - |
| D | - | - | - | - | - |
| E | - | - | - | - | - |
| F | - | - | - | - | - |

Provides a rigid joint for two tubes of the same dia. Joints to be 150mm to the nearest support. Do not use for joining two tubes subject to extreme loads, i.e. a vertical post member supporting a guardrail. Use A9 for a streamline joint.



A09

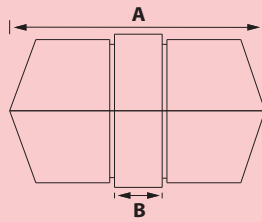

| Tube size | 6 (B)=33.7mm dia. | 7 (C)=42.4mm dia. | 8 (D)=48.3mm dia. |
|-----------|-------------------|-------------------|-------------------|
| A | 78 | 78 | 80 |
| B | 20 | 20 | 20 |
| C | - | - | - |
| D | - | - | - |
| E | - | - | - |
| F | - | - | - |

Provides a streamline flush joint in two tubes of the same diameter with a maximum wall thickness of 3.2mm. Joints to be 150mm to the nearest support. Not for joining tubes that are subject to extreme loads, or where a direct tensile load is applied.



A10

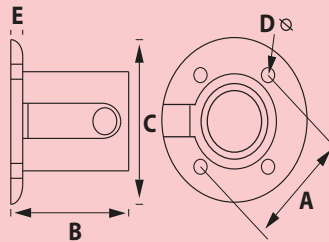

| Tube size | 5 (A)=26.9mm dia. | 6 (B)=33.7mm dia. | 7 (C)=42.4mm dia. | 8 (D)=48.3mm dia. | 9 (E)= 60.3mm dia. |
|-----------|-------------------|-------------------|-------------------|-------------------|--------------------|
| A | 63 | 65 | 75 | 85 | 96 |
| B | 48 | 48 | 51 | 54 | 60 |
| C | 81 | 84 | 98 | 112 | 130 |
| D | 6 | 6 | 6 | 10 | 7 |
| E | 4 | 4 | 6 | 6 | 6 |
| F | - | - | - | - | - |

A four holed plate provides a rigid fixing for handrails that terminate on walls. Ideal for securing garment railing structures to ceilings etc. Not to be used as structural fixings for supporting a vertical post on guardrails. Use A12 for this.

**Procure product prior to pre-drilling holes in structures as some dimensions may vary.



A12

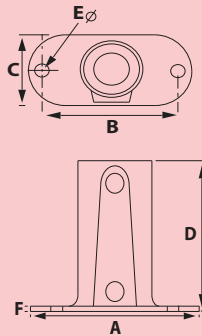

| Tube size | 5 (A)=26.9mm dia. | 6 (B)=33.7mm dia. | 7 (C)=42.4mm dia. | 8 (D)=48.3mm dia. | 9 (E)= 60.3mm dia. |
|-----------|-------------------|-------------------|-------------------|-------------------|--------------------|
| A | 112 | 128 | 144 | 156 | 165 |
| B | 76 | 88 | 102 | 114 | 126 |
| C | 64 | 80 | 80 | 92 | 98 |
| D | 76 | 88 | 88 | 88 | 130 |
| E | 11 | 14 | 14 | 14 | 18 |
| F | 8 | 10 | 10 | 10 | 8 |

Provides a structural base plate for the support of a vertical post typically for a guardrail. Two socket screws give a rigid structural fixing. Recommended that the fixing down bolts be in line with the applied load. (i.e 90 to the rails).

**Procure product prior to pre-drilling holes in structures as some dimensions may vary

A13

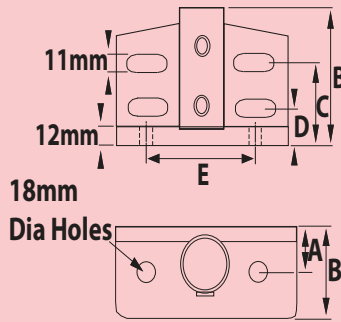

Tube size

7 (C)=42.4mm dia.
8 (D)=48.3mm dia.

| | A | B | C | D | E | F |
|-------------------|----|----|----|----|-----|---|
| | - | - | - | - | - | - |
| 7 (C)=42.4mm dia. | 45 | 90 | 58 | 30 | 100 | - |
| 8 (D)=48.3mm dia. | 45 | 90 | 58 | 30 | 100 | - |
| | - | - | - | - | - | - |

Base plate with integrated toe board attachment. Primarily for guardrails that require more stringent safety requirements. 150mm high steel plate can be attached in sections by fixing through slotted holes. Refer to company post centres and current legislation on installation. **Procure prior to pre-drilling holes in structures as dimensions may vary.

A14

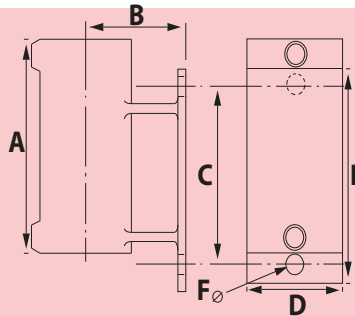

Tube size

6 (B)=33.7mm dia.
7 (C)=42.4mm dia.
8 (D)=48.3mm dia.

| | A | B | C | D | E | F |
|-------------------|-----|----|----|----|-----|----|
| | - | - | - | - | - | - |
| 6 (B)=33.7mm dia. | 104 | 64 | 68 | 44 | 98 | 14 |
| 7 (C)=42.4mm dia. | 114 | 64 | 74 | 50 | 112 | 14 |
| 8 (D)=48.3mm dia. | 120 | 64 | 90 | 60 | 124 | 14 |
| | - | - | - | - | - | - |

Base for vertical posts for side mounting. Posts stand off from structure. Tube cannot pass through this clamp. Access to top fixing hole restricted, a threaded stud type bolt projected a maximum of 25mm from structure needs to be fixed first. **Procure product prior to pre-drilling holes in structures as some dimensions may vary.

A15

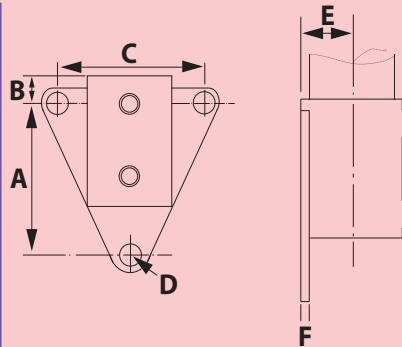
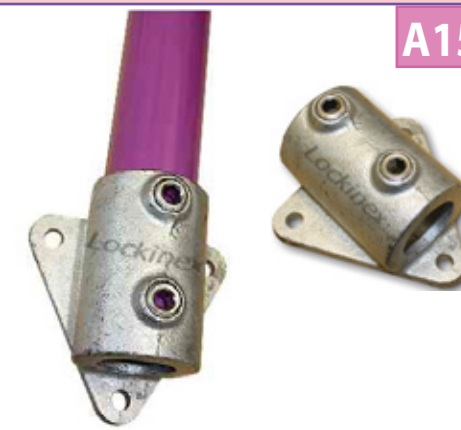

Tube size

6 (B)=33.7mm dia.
7 (C)=42.4mm dia.
8 (D)=48.3mm dia.

| | A | B | C | D | E | F |
|-------------------|----|----|---|----|----|---|
| | - | - | - | - | - | - |
| 6 (B)=33.7mm dia. | 63 | 25 | * | 11 | 24 | 6 |
| 7 (C)=42.4mm dia. | 72 | 23 | * | 11 | 28 | 6 |
| 8 (D)=48.3mm dia. | 78 | 23 | * | 11 | 31 | 6 |
| | - | - | - | - | - | - |

Provides a structural base plate to a vertical post that is required to be side mounted. This clamp is virtually flush to structure it is being fixed to. The tube does not pass through the clamp. **Procure product prior to pre-drilling holes in structures as some dimensions may vary.

A16

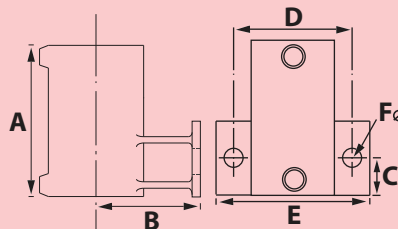

Tube size

6 (B)=33.7mm dia.
7 (C)=42.4mm dia.
8 (D)=48.3mm dia.

| | A | B | C | D | E | F |
|-------------------|-----|----|----|----|-----|----|
| | - | - | - | - | - | - |
| 6 (B)=33.7mm dia. | 114 | 64 | 24 | 66 | 98 | 14 |
| 7 (C)=42.4mm dia. | 114 | 64 | 27 | * | 104 | 14 |
| 8 (D)=48.3mm dia. | 120 | 64 | 30 | * | 114 | 14 |
| | - | - | - | - | - | - |

Provides a structural base plate as the A14, should not be used for heavy duty applications. **Procure product prior to pre-drilling holes in structures as some dimensions may vary.

A16FM

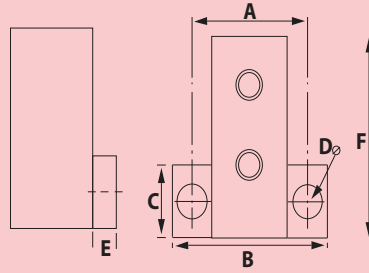

Tube size

- 6 (B)=33.7mm dia.
- 7 (C)=42.4mm dia.
- 8 (D)=48.3mm dia.

| | A | B | C | D | E | F |
|-------------------|-----|-----|----|----|----|----|
| 6 (B)=33.7mm dia. | 100 | 150 | 65 | 18 | 10 | 90 |
| 7 (C)=42.4mm dia. | 100 | 150 | 65 | 18 | 0 | 90 |
| 8 (D)=48.3mm dia. | 100 | 150 | 65 | 18 | 10 | 90 |
| | - | - | - | - | - | - |

As the A16 but designed to take higher loads.

**Procure product prior to pre-drilling holes in structures as some dimensions may vary.

A17

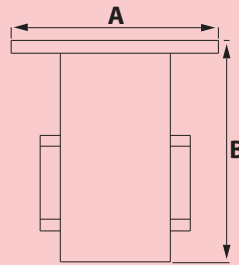
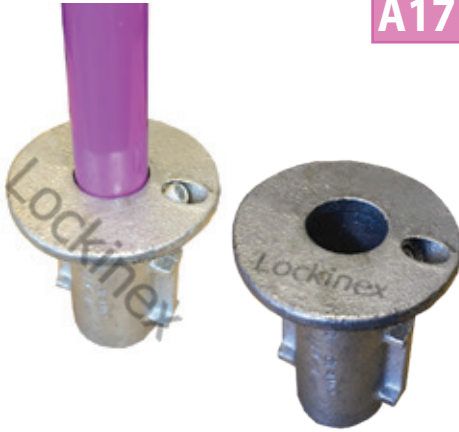

Tube size

- 6 (B)=33.7mm dia.
- 7 (C)=42.4mm dia.
- 8 (D)=48.3mm dia.

| | A | B | | | | |
|-------------------|-----|-----|---|---|---|---|
| 6 (B)=33.7mm dia. | 126 | 125 | - | - | - | - |
| 7 (C)=42.4mm dia. | 140 | 135 | - | - | - | - |
| 8 (D)=48.3mm dia. | 140 | 138 | - | - | - | - |
| | - | - | - | - | - | - |

A ground socket that is cast into concrete and is flush with the finished ground level. Allow posts to be inserted and retained with a locking set screw. Posts can be easily removed at any time.

**Procure product prior to pre-drilling holes in structures as some dimensions may vary.

A18

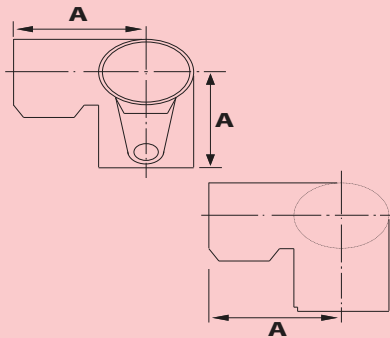
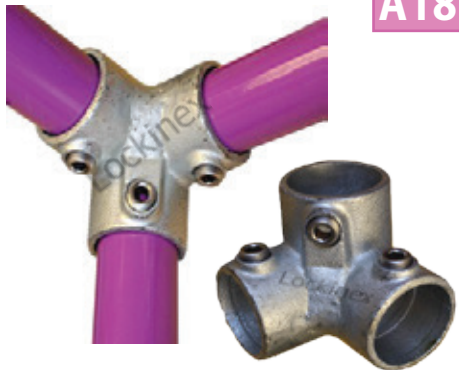

Tube size

- 5 (A)=26.9mm dia.
- 6 (B)=33.7mm dia.
- 7 (C)=42.4mm dia.
- 8 (D)=48.3mm dia.
- 9 (E)= 60.3mm dia.

| | A | B | C | D | E | F |
|--------------------|----|---|---|---|---|---|
| 5 (A)=26.9mm dia. | 44 | - | - | - | - | - |
| 6 (B)=33.7mm dia. | 48 | - | - | - | - | - |
| 7 (C)=42.4mm dia. | 60 | - | - | - | - | - |
| 8 (D)=48.3mm dia. | 68 | - | - | - | - | - |
| 9 (E)= 60.3mm dia. | 85 | - | - | - | - | - |

Provides a three way 90 degree corner joint. Used frequently for top rail 90 turn where a post is present. Compliment this with A20 for a lower rail. Also used for corner joints on structures such as work benches, tables etc.

A20

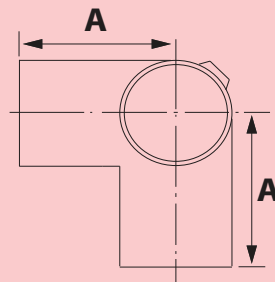

Tube size

- 5 (A)=26.9mm dia.
- 6 (B)=33.7mm dia.
- 7 (C)=42.4mm dia.
- 8 (D)=48.3mm dia.
- 9 (E)= 60.3mm dia.

| | A | B | C | D | E | F |
|--------------------|----|---|---|---|---|---|
| 5 (A)=26.9mm dia. | 44 | - | - | - | - | - |
| 6 (B)=33.7mm dia. | 48 | - | - | - | - | - |
| 7 (C)=42.4mm dia. | 60 | - | - | - | - | - |
| 8 (D)=48.3mm dia. | 68 | - | - | - | - | - |
| 9 (E)= 60.3mm dia. | 85 | - | - | - | - | - |

A 90 degree corner joint, tube passes through the central hole. Used frequently for a lower rail(s). Often used in conjunction with the A18.

A20R (Retro fit)

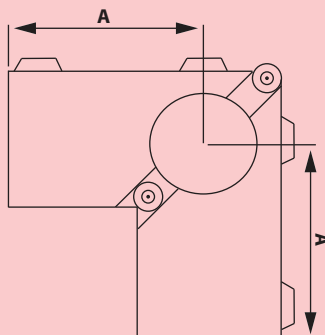

Tube size

8 (D)=48.3mm dia.

| A |
|----|
| - |
| - |
| - |
| - |
| 88 |
| - |
| - |
| - |

Provides the same function as the A20. However, this clamp can be retro fitted to an existing installation so disassembly is not required. The clamp can be split in half by removal of the pins and fitted to the existing structure.

A21

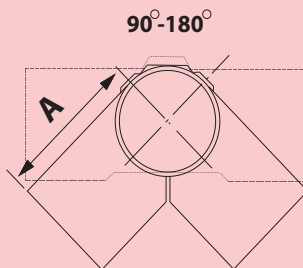

Tube size

6 (B)=33.7mm dia.

7 (C)=42.4mm dia.

8 (D)=48.3mm dia.

| A | B | C | D | E | F |
|----|---|---|---|---|---|
| - | - | - | - | - | - |
| 58 | - | - | - | - | - |
| 73 | - | - | - | - | - |
| 81 | - | - | - | - | - |
| - | - | - | - | - | - |

Generally used in pairs (as shown). Allows angles between 90 -180 . Used to change direction of rails in the same plane. Requires a central tube at the point of angle change. Consider the A7 as an alternative for the angle change.

A22

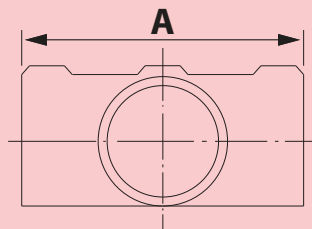

Tube size

5 (A)=26.9mm dia.

6 (B)=33.7mm dia.

7 (C)=42.4mm dia.

8 (D)=48.3mm dia.

9 (E)= 60.3mm dia.

| A |
|-----|
| 88 |
| 96 |
| 120 |
| 136 |
| 175 |

Used for a 90 degree connection of a lower rail(s) to an intermediate vertical post, the vertical post must remain continuous while the rail is joined in each side of the clamp. Usually complimented with the A4 when used for guardrailing.

A22R (Retro fit)

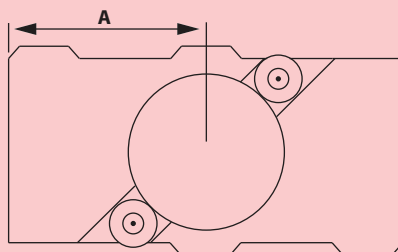

Tube size

8 (D)=48.3mm dia.

| A |
|----|
| - |
| - |
| - |
| - |
| 88 |
| - |
| - |
| - |

Provides the same function as the A22. However, this clamp can be retro fitted to an existing installation so disassembly is not required. The clamp can be split in half by removal of the pins and fitted to the existing structure.



A23

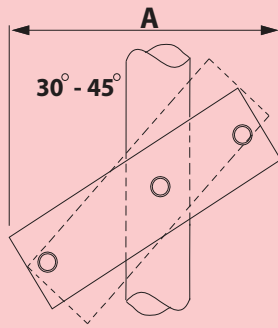

| Tube size | A | B | C | D | E | F |
|--------------------------|-----|---|---|---|---|---|
| | - | - | - | - | - | - |
| 6 (B)=33.7mm dia. | 146 | - | - | - | - | - |
| 7 (C)=42.4mm dia. | 178 | - | - | - | - | - |
| 8 (D)=48.3mm dia. | 216 | - | - | - | - | - |
| | - | - | - | - | - | - |

Variable angle clamp enables tubes to be connected between angles 30 -45 degrees. Used for angled lower rail(s) joint to a vertical post on stairs. A3 can be used in association for top rail connection. A46 swivel clamp is an alternative.

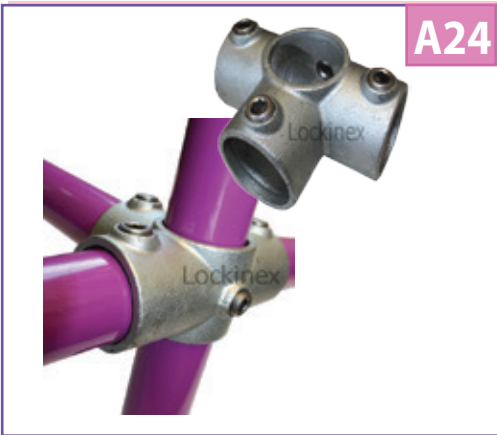

A24

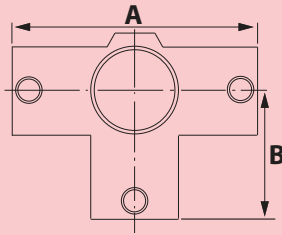

| Tube size | A | B | C | D | E | F |
|---------------------------|-----|----|---|---|---|---|
| 5 (A)=26.9mm dia. | 88 | 44 | - | - | - | - |
| 6 (B)=33.7mm dia. | 96 | 48 | - | - | - | - |
| 7 (C)=42.4mm dia. | 120 | 60 | - | - | - | - |
| 8 (D)=48.3mm dia. | 136 | 68 | - | - | - | - |
| 9 (E)= 60.3mm dia. | 170 | 86 | - | - | - | - |

Frequently used to tie uprights with horizontal tubes in three directions all at 90 degrees to the upright.



A24R (Retro fit)

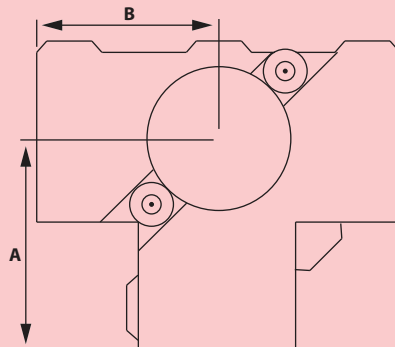

| Tube size | A | B |
|--------------------------|----|----|
| | - | - |
| | - | - |
| | - | - |
| 8 (D)=48.3mm dia. | 85 | 88 |
| | - | - |

Provides the same function as the A24. However, this clamp can be retro fitted to an existing installation so disassembly is not required. The clamp can be split in half by removal of the pins and fitted to the existing structure.



A25

| Tube size |
|--------------------------|
| |
| |
| |
| 8 (D)=48.3mm dia. |
| |

Swivel elbow clamp often used where stair case top rails join level top rails. The swivel connection is created using a rivet. Please note that swivel clamps should not be used to create entire structures as stability may not be sufficient.

A26

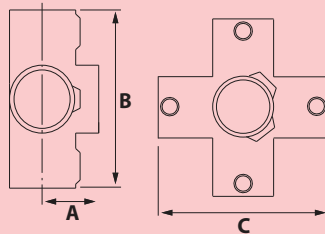

Tube size

| | A | B | C | D | E | F |
|--------------------|----|-----|-----|---|---|---|
| 5 (A)=26.9mm dia. | 32 | 82 | 82 | - | - | - |
| 6 (B)=33.7mm dia. | 43 | 96 | 96 | - | - | - |
| 7 (C)=42.4mm dia. | 48 | 120 | 120 | - | - | - |
| 8 (D)=48.3mm dia. | 50 | 136 | 136 | - | - | - |
| 9 (E)= 60.3mm dia. | 54 | 175 | - | - | - | - |

Frequently used in structures that have many uprights, such as racking. This clamp ties a centre upright, which passes through the central hole, with four horizontal tubes. All connections are at 90 degrees to each other.

A26R (Retro fit)

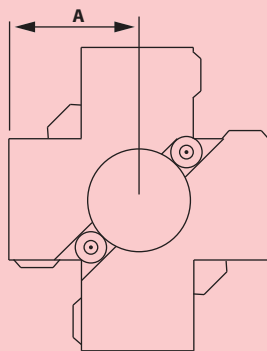

Tube size

| | A |
|-------------------|----|
| | - |
| | - |
| | - |
| 8 (D)=48.3mm dia. | 88 |
| | - |
| | - |

Provides the same function as the A26. However, this clamp can be retro fitted to an existing installation so disassembly is not required. The clamp can be split in half by removal of the pins and fitted to the existing structure.

A27



Tube size

| | |
|-------------------|---|
| | - |
| | - |
| | - |
| 8 (D)=48.3mm dia. | - |
| | - |
| | - |

Swivel T clamp often used where stair case middle rails join level middle rails. The swivel joint is created using a rivet. Please note that swivel clamps should not be used to create entire structures as stability may not be sufficient.

A28

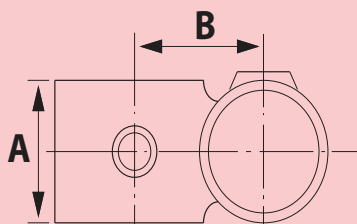

Tube size

| | A | B |
|--------------------|----|----|
| 5 (A)=26.9mm dia. | 36 | 32 |
| 6 (B)=33.7mm dia. | 42 | 40 |
| 7 (C)=42.4mm dia. | 54 | 49 |
| 8 (D)=48.3mm dia. | 60 | 54 |
| 9 (E)= 60.3mm dia. | 62 | 68 |

Provides a 90 degree crossover joint. Used in guardrail installations. Rails are passed through in long lengths and joined using the A8 or A9. Can be used for connection of a horizontal racking member to a vertical support, garment rails etc.

A28R (Retro fit)

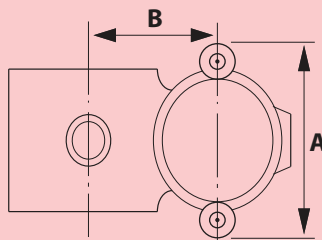

Tube size

| | A | B | | | |
|-------------------|----|----|---|---|---|
| | - | - | - | - | - |
| | - | - | - | - | - |
| | - | - | - | - | - |
| 8 (D)=48.3mm dia. | 67 | 55 | - | - | - |
| | - | - | - | - | - |

Provides the same function as the A28. However, this clamp can be retro fitted to an existing installation so disassembly is not required. One side of the clamp can be split in half by removal of the pins and fitted to the existing structure.

A28 (2 sizes)

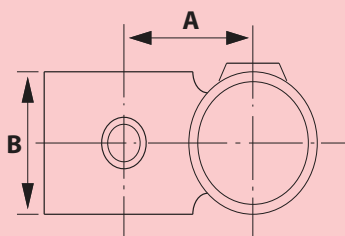

Tube size

| | A | B | | | |
|------------------------------|----|----|---|---|---|
| | - | - | - | - | - |
| | - | - | - | - | - |
| | - | - | - | - | - |
| 8 x 6 (C)=42.4 & 33.7mm dia. | 45 | 39 | - | - | - |
| 8 x 7 (D)=48.3 & 42.4mm dia. | 49 | 45 | - | - | - |
| | - | - | - | - | - |

Provides the same function as the A28. However, this clamp can accept two different sized diameter tubes.

A29



Tube size

| | | | | | |
|-------------------|---|---|---|---|---|
| | - | - | - | - | - |
| | - | - | - | - | - |
| | - | - | - | - | - |
| 6 (B)=33.7mm dia. | - | - | - | - | - |
| 7 (C)=42.4mm dia. | - | - | - | - | - |
| 8 (D)=48.3mm dia. | - | - | - | - | - |
| | - | - | - | - | - |

Rigid 45 degree angle short T fitting.

A30

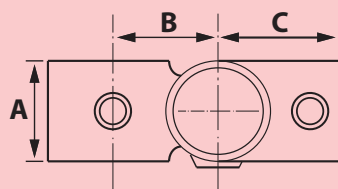

Tube size

| | | | | | | |
|--|----|----|----|---|---|---|
| | 31 | 35 | 41 | - | - | - |
| | 42 | 40 | 48 | - | - | - |
| | 54 | 49 | 60 | - | - | - |
| | 60 | 54 | 68 | - | - | - |
| | 62 | 68 | 86 | - | - | - |

This clamp is used on racking for the 90 degree connection of a vertical support to a horizontal load carrying rail. The rear outlet is available for a horizontal tie across the section.

A31

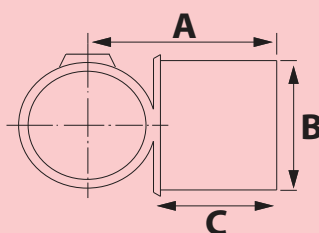

Tube size

| | A | B | C | D | E | F |
|--|----|----|----|---|---|---|
| | - | - | - | - | - | - |
| | 56 | 33 | 33 | - | - | - |
| | 62 | 42 | 36 | - | - | - |
| | 72 | 48 | 41 | - | - | - |
| | - | - | - | - | - | - |

Offset handrail spigot clamp accepts tube through top of the 'T', the spigot inserts directly into another clamp. Used for off setting rail from a post, can be rotated through 360 degree. Used with A6 and A2. Also use with A10 for wall mounted rail.



A32

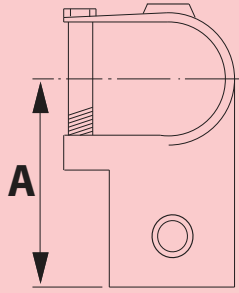

Tube size

5 (A)=26.9mm dia.
 6 (B)=33.7mm dia.
 7 (C)=42.4mm dia.
 8 (D)=48.3mm dia.
 9 (E)= 60.3mm dia.

| | A | B | C | D | E | F |
|---|----|---|---|---|---|---|
| 5 | 50 | - | - | - | - | - |
| 6 | 54 | - | - | - | - | - |
| 7 | 64 | - | - | - | - | - |
| 8 | 74 | - | - | - | - | - |
| 9 | 90 | - | - | - | - | - |

Used for adding to and modifying an existing structure. Similar to the A2.



A34

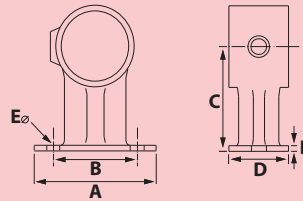

Tube size

5 (A)=26.9mm dia.
 6 (B)=33.7mm dia.
 7 (C)=42.4mm dia.
 8 (D)=48.3mm dia.

| | A | B | C | D | E | F |
|---|-----|----|----|----|----|----|
| 5 | 76 | 57 | 55 | 45 | 8 | 5 |
| 6 | 92 | 62 | 58 | 48 | 10 | 10 |
| 7 | 112 | 75 | 60 | 48 | 10 | 10 |
| 8 | 112 | 84 | 68 | 54 | 10 | 10 |
| | - | - | - | - | - | - |

Used to carry handrails along walls or fix structures back to walls. Tube passes through in long lengths, can be joined using the A8 or A9. Can be slid down a post and used for connecting a kick plate. Also for fixing hoardings, signs etc.



A35

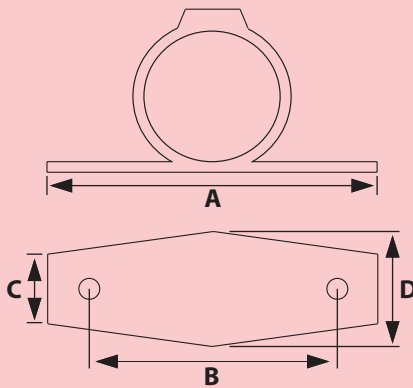

Tube size

5 (A)=26.9mm dia.
 6 (B)=33.7mm dia.
 7 (C)=42.4mm dia.
 8 (D)=48.3mm dia.

| | A | B | C | D |
|---|---|---|---|---|
| 5 | - | - | - | - |
| 6 | - | - | - | - |
| 7 | - | - | - | - |
| 8 | - | - | - | - |
| | - | - | - | - |

Allows for fixing to various panels (such as wood) in order to create a flush fitting. **Procure product prior to pre-drilling holes in structures as some dimensions may vary.



A36

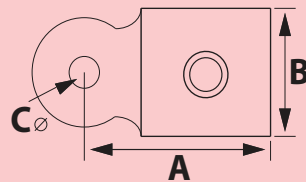

Tube size

5 (A)=26.9mm dia.
 6 (B)=33.7mm dia.
 7 (C)=42.4mm dia.
 8 (D)=48.3mm dia.
 9 (E)= 60.3mm dia.

| | A | B | C | D | E | F |
|---|-----|----|----|---|---|---|
| 5 | 56 | 39 | 10 | - | - | - |
| 6 | 66 | 39 | 10 | - | - | - |
| 7 | 75 | 45 | 10 | - | - | - |
| 8 | 75 | 45 | 10 | - | - | - |
| 9 | 100 | 50 | 10 | - | - | - |

This is a part component of the A44. It can be used on it's own for the insertion of signs and hoardings within a tubular frame, the connection of chain and 'D' shackles and tensioning of yachting wire balustrades etc.

A37

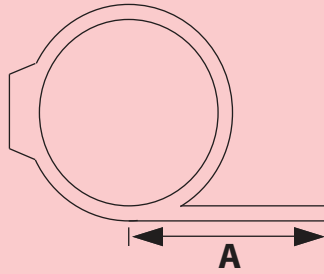

| Tube size | A |
|-------------------|---------------|
| 5 (A)=26.9mm dia. | N/A - - - - - |
| 6 (B)=33.7mm dia. | 43 - - - - - |
| 7 (C)=42.4mm dia. | 48 - - - - - |
| 8 (D)=48.3mm dia. | 52 - - - - - |
| | - - - - - |

| A | B | C | D | E | F |
|-----|---|---|---|---|---|
| N/A | - | - | - | - | - |
| 43 | - | - | - | - | - |
| 48 | - | - | - | - | - |
| 52 | - | - | - | - | - |
| - | - | - | - | - | - |

Often used to allow the fixing of boards which sit practically flush with the tube.
 **Procure product prior to pre-drilling holes in structures as some dimensions may vary.

A38

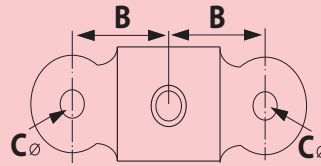

| Tube size | A | B | C | D | E | F |
|--------------------|-----|----|----|---|---|---|
| 5 (A)=26.9mm dia. | 112 | 38 | 10 | - | - | - |
| 6 (B)=33.7mm dia. | 123 | 43 | 10 | - | - | - |
| 7 (C)=42.4mm dia. | 134 | 47 | 10 | - | - | - |
| 8 (D)=48.3mm dia. | 142 | 51 | 10 | - | - | - |
| 9 (E)= 60.3mm dia. | 160 | 56 | 10 | - | - | - |

| A | B | C | D | E | F |
|-----|----|----|---|---|---|
| 112 | 38 | 10 | - | - | - |
| 123 | 43 | 10 | - | - | - |
| 134 | 47 | 10 | - | - | - |
| 142 | 51 | 10 | - | - | - |
| 160 | 56 | 10 | - | - | - |

Similar to the A36 but with two eyelets. This is a part component of the A46.

A40

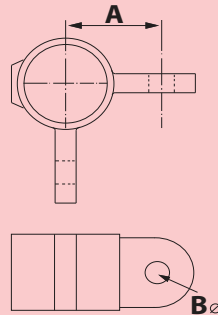

| Tube size | A | B | C | D | E | F |
|-------------------|----|----|---|---|---|---|
| 5 (A)=26.9mm dia. | 38 | 10 | - | - | - | - |
| 6 (B)=33.7mm dia. | 46 | 10 | - | - | - | - |
| 7 (C)=42.4mm dia. | 48 | 10 | - | - | - | - |
| 8 (D)=48.3mm dia. | 54 | 10 | - | - | - | - |
| | - | - | - | - | - | - |

| A | B | C | D | E | F |
|----|----|---|---|---|---|
| 38 | 10 | - | - | - | - |
| 46 | 10 | - | - | - | - |
| 48 | 10 | - | - | - | - |
| 54 | 10 | - | - | - | - |
| - | - | - | - | - | - |

Similar to the A38 but the two eyelets are at 90 degrees . This is a part component of the A48.

A41

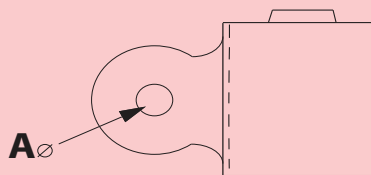

| Tube size | A |
|-------------------|--------------|
| 6 (B)=33.7mm dia. | 12 - - - - - |
| 7 (C)=42.4mm dia. | 12 - - - - - |
| 8 (D)=48.3mm dia. | 12 - - - - - |
| | - - - - - |

| A | B | C | D | E | F |
|----|---|---|---|---|---|
| 12 | - | - | - | - | - |
| 12 | - | - | - | - | - |
| 12 | - | - | - | - | - |
| - | - | - | - | - | - |

Socket with single eye

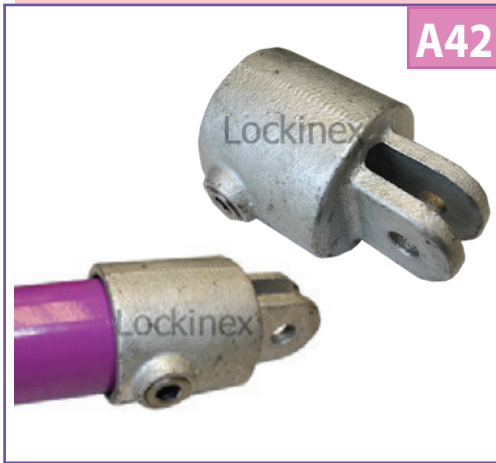

A42

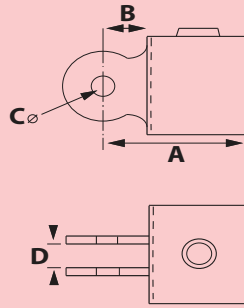

Tube size

- 5 (A)=26.9mm dia.
- 6 (B)=33.7mm dia.
- 7 (C)=42.4mm dia.
- 8 (D)=48.3mm dia.
- 9 (E)= 60.3mm dia.

| | A | B | C | D |
|---|----|----|----|----|
| 5 | 61 | 25 | 10 | 12 |
| 6 | 61 | 25 | 10 | 12 |
| 7 | 70 | 25 | 10 | 12 |
| 8 | 77 | 25 | 10 | 12 |
| 9 | 94 | 36 | 10 | 12 |

Socket - Part component of the A44, A46, A48, A52.



A44

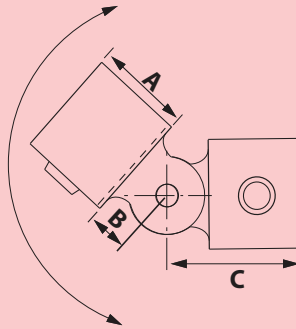

Tube size

- 5 (A)=26.9mm dia.
- 6 (B)=33.7mm dia.
- 7 (C)=42.4mm dia.
- 8 (D)=48.3mm dia.
- 9 (E)= 60.3mm dia.

| | A | B | C |
|---|----|----|-----|
| 5 | 34 | 25 | 56 |
| 6 | 36 | 25 | 66 |
| 7 | 45 | 25 | 75 |
| 8 | 53 | 25 | 75 |
| 9 | 58 | 36 | 100 |

A flexible variable angle connector. Used for an angled top rail connection to a post. Use if the angle required is not known. Also used as bracing struts for racking etc. Reducing combinations are available throughout the size range.



A46

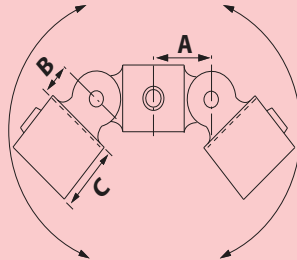

Tube size

- 5 (A)=26.9mm dia.
- 6 (B)=33.7mm dia.
- 7 (C)=42.4mm dia.
- 8 (D)=48.3mm dia.
- 9 (E)= 60.3mm dia.

| | A | B | C | D | E | F |
|---|----|----|----|---|---|---|
| 5 | 38 | 25 | 36 | - | - | - |
| 6 | 43 | 25 | 36 | - | - | - |
| 7 | 47 | 25 | 45 | - | - | - |
| 8 | 51 | 25 | 53 | - | - | - |
| 9 | 56 | 36 | 58 | - | - | - |

A flexible variable connection used for an angled lower rail(s) joint to a post. Changes horizontal rails to angled rails at top of ramps/stairs. Also as bracing struts for racking. Reducing combinations available throughout the size range.



A48

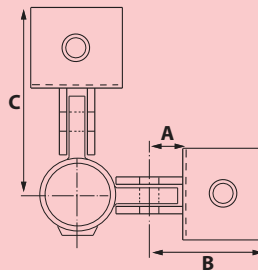

Tube size

- 5 (A)=26.9mm dia.
- 6 (B)=33.7mm dia.
- 7 (C)=42.4mm dia.
- 8 (D)=48.3mm dia.

| | A | B | C | D | E | F |
|---|----|----|-----|---|---|---|
| 5 | 25 | 61 | 99 | - | - | - |
| 6 | 25 | 61 | 107 | - | - | - |
| 7 | 25 | 70 | 118 | - | - | - |
| 8 | 25 | 78 | 132 | - | - | - |
| | - | - | - | - | - | - |

A 90 degree flexible variable angled connector for posts on a corner. Changes horizontal rails to angled rails, at the top of a ramp/stairs. Use as bracing struts for racking etc. Reducing combinations available throughout the size range.

A50

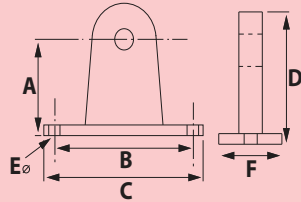

One size

| A | B | C | D | E | F |
|----|----|-----|----|----|----|
| 40 | 84 | 116 | 54 | 12 | 48 |
| - | - | - | - | - | - |
| - | - | - | - | - | - |
| - | - | - | - | - | - |
| - | - | - | - | - | - |

A part component of the A52. Used on it's own it is ideal for a wall fixing for a chain attachment with a 'D' shackle. Can be used to take steel straining wires etc. Can be fixed to floor to provide fixing point for mesh panels/kick plates.

**Procure product prior to pre-drilling holes in structures as some dimensions may vary.

A52

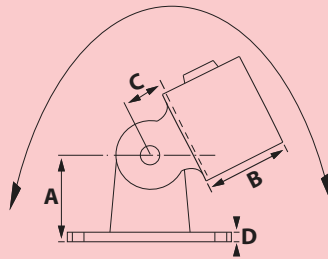

Tube size

- 5 (A)=26.9mm dia.
- 6 (B)=33.7mm dia.
- 7 (C)=42.4mm dia.
- 8 (D)=48.3mm dia.
- 9 (E)= 60.3mm dia.

| A | B | C | D | E | F |
|----|----|----|----|---|---|
| 40 | 34 | 25 | 10 | - | - |
| 40 | 36 | 25 | 10 | - | - |
| 40 | 45 | 25 | 10 | - | - |
| 40 | 53 | 25 | 10 | - | - |
| 40 | 58 | 36 | 10 | - | - |

Used for an angled wall fixing plate or strut for added strengthening of a post. Not to be used as an angled base plate. Consider the G12. Alternatively use A12 and bend the vertical tube to the upright position.

**Procure product prior to pre-drilling holes in structures as some dimensions may vary.

A54

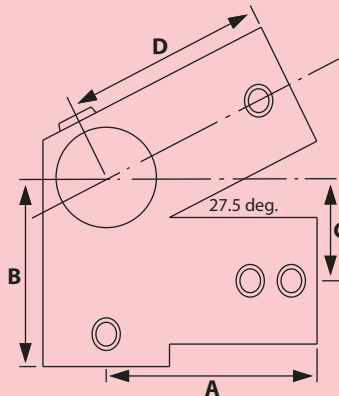

Tube size

- 8 (D)=48.3mm dia.

| A | B | C | D | E | F |
|----|----|----|----|---|---|
| - | - | - | - | - | - |
| - | - | - | - | - | - |
| - | - | - | - | - | - |
| 83 | 93 | 55 | 70 | - | - |
| - | - | - | - | - | - |

Commonly used to create roof structures in association with the A56. The tube cannot be joined within the fitting.

A56

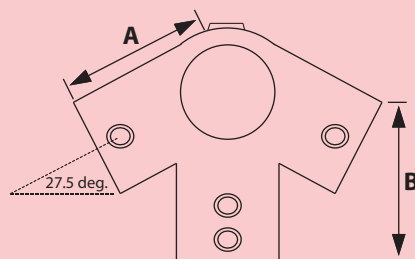

Tube size

- 8 (D)=48.3mm dia.

| A | B | C | D | E | F |
|----|----|---|---|---|---|
| - | - | - | - | - | - |
| - | - | - | - | - | - |
| - | - | - | - | - | - |
| 68 | 95 | - | - | - | - |
| - | - | - | - | - | - |

Commonly used to create roof structures in association with the A54. The tube cannot be joined within the fitting.



A58

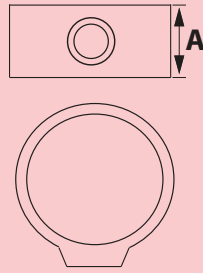

| Tube size | A | B | C | D | E | F |
|-------------------|---|---|---|---|---|---|
| 5 (A)=26.9mm dia. | * | - | - | - | - | - |
| 6 (B)=33.7mm dia. | * | - | - | - | - | - |
| 7 (C)=42.4mm dia. | * | - | - | - | - | - |
| 8 (D)=48.3mm dia. | * | - | - | - | - | - |

Used for the added support of a clamp that may be subject to severe loading, in excess of the maximum permitted slip load of it's socket set screw, on racking etc. Can support another clamp, which doesn't have it's socket screw tightened.



A60

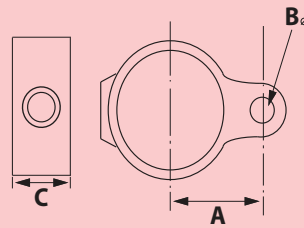

| Tube size | A | B | C | D | E | F |
|-------------------|----|----|----|---|---|---|
| 5 (A)=26.9mm dia. | 30 | 12 | 25 | - | - | - |
| 6 (B)=33.7mm dia. | 33 | 12 | 27 | - | - | - |
| 7 (C)=42.4mm dia. | 37 | 12 | 27 | - | - | - |
| 8 (D)=48.3mm dia. | 40 | 13 | 27 | - | - | - |
| | - | - | - | - | - | - |

Used in conjunction with the A62 for a gate hinge assembly. Consider the Lockinex ready made self closing gate and posts for an alternative.



A62

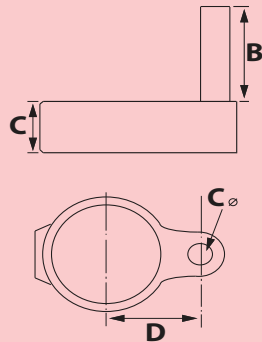

| Tube size | A | B | C | D | E | F |
|-------------------|----|----|----|----|---|---|
| 5 (A)=26.9mm dia. | 25 | 34 | 11 | 30 | - | - |
| 6 (B)=33.7mm dia. | 27 | 34 | 11 | 33 | - | - |
| 7 (C)=42.4mm dia. | 27 | 38 | 12 | 37 | - | - |
| 8 (D)=48.3mm dia. | 27 | 38 | 12 | 40 | - | - |
| | - | - | - | - | - | - |

Used in conjunction with the A60 for a gate hinge assembly. Consider the Lockinex ready made self closing gate and posts for an alternative.



A64

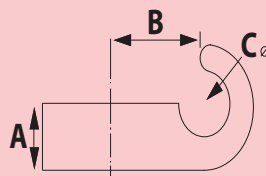

| Tube size | A | B | C | D | E | F |
|-------------------|----|----|----|---|---|---|
| 5 (A)=26.9mm dia. | 25 | 32 | 20 | - | - | - |
| 6 (B)=33.7mm dia. | 25 | 34 | 24 | - | - | - |
| 7 (C)=42.4mm dia. | 25 | 39 | 24 | - | - | - |
| 8 (D)=48.3mm dia. | 25 | 41 | 24 | - | - | - |
| | - | - | - | - | - | - |

This clamp is generally used on a vertical post where chain is connected for an access opening in a guardrail. The chain is easily removed from the A64, use an A36 and a 'D' shackle for the opposite end connection.



A66

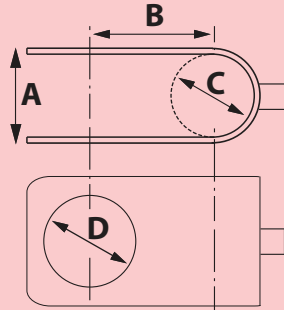

| Tube size | A | B | C | D | E | F |
|--------------------|----|----|----|----|---|---|
| 5 (A)=26.9mm dia. | 35 | 27 | 27 | 27 | - | - |
| 6 (B)=33.7mm dia. | 42 | 34 | 34 | 34 | - | - |
| 7 (C)=42.4mm dia. | 50 | 42 | 42 | 42 | - | - |
| 8 (D)=48.3mm dia. | 56 | 48 | 48 | 48 | - | - |
| 9 (E)= 60.3mm dia. | - | - | - | - | - | - |

This clamp can be added to an existing structure. It provides a 90 degree crossover connection. This product may be supplied as a mild steel manufactured item, or cast iron. This is dependant on availability.



A67

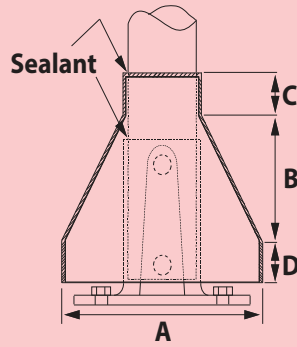

| Tube size | A | B | C | D | E | F |
|-------------------|-----|-----|----|----|---|---|
| 7 (C)=42.4mm dia. | 153 | 105 | 22 | 26 | - | - |
| 8 (D)=48.3mm dia. | 168 | 112 | 22 | 26 | - | - |
| | - | - | - | - | - | - |

Used on asphalt roofs to provide a rain shield. Slides down the post over the A12 base flange. Once installed a silicone seal should be made between the tube circumference and the top of the cowling. Made from spun steel.



A68

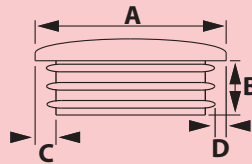

| Tube size | A | B | C | D |
|--------------------|------|----|------|-----|
| 5 (A)=26.9mm dia. | 26.9 | 13 | 1.25 | 2.6 |
| 6 (B)=33.7mm dia. | 33.7 | 16 | 2.6 | 4 |
| 7 (C)=42.4mm dia. | 42.4 | 16 | 2.6 | 4 |
| 8 (D)=48.3mm dia. | 48.3 | 18 | 3.2 | 5 |
| 9 (E)= 60.3mm dia. | 60.3 | 20 | 3.2 | 5 |

These plastic caps are used to plug the ends of the tubing. Once in position they are extremely difficult to remove.



A69

| Tube size | A | B | C | D | E | F |
|--------------------|---|---|---|---|---|---|
| 5 (A)=26.9mm dia. | - | - | - | - | - | - |
| 6 (B)=33.7mm dia. | - | - | - | - | - | - |
| 7 (C)=42.4mm dia. | - | - | - | - | - | - |
| 8 (D)=48.3mm dia. | - | - | - | - | - | - |
| 9 (E)= 60.3mm dia. | - | - | - | - | - | - |

These galvanised caps are used to plug the ends of the tubing.



A70

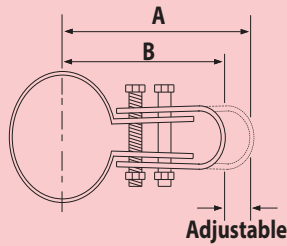

Tube size

- 5 (A)=26.9mm dia.
- 6 (B)=33.7mm dia.
- 7 (C)=42.4mm dia.
- 8 (D)=48.3mm dia.
- 9 (E)= 60.3mm dia.

| | A | B | C | D | E | F |
|---|----|----|---|---|---|---|
| 5 | 68 | 58 | - | - | - | - |
| 6 | 71 | 61 | - | - | - | - |
| 7 | 75 | 65 | - | - | - | - |
| 8 | 78 | 68 | - | - | - | - |
| 9 | 76 | 66 | - | - | - | - |

Used to retain mesh panels within a guardrail. Used without the 'horseshoe' end they can secure other types of infill with a maximum thickness of 10mm, such as perspex/plywood. Can be added to an existing structure. Space 450mm apart.



A72

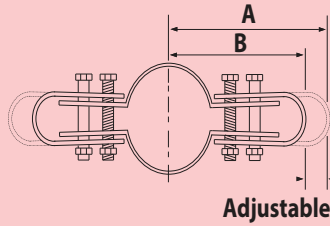

Tube size

- 5 (A)=26.9mm dia.
- 6 (B)=33.7mm dia.
- 7 (C)=42.4mm dia.
- 8 (D)=48.3mm dia.
- 9 (E)= 60.3mm dia.

| | A | B | | | |
|---|----|----|---|---|---|
| 5 | 58 | 48 | - | - | - |
| 6 | 71 | 61 | - | - | - |
| 7 | 75 | 65 | - | - | - |
| 8 | 78 | 68 | - | - | - |
| 9 | 76 | 66 | - | - | - |

Used to retain mesh panels within a guardrail. Used without the 'horseshoe' end they can secure other types of infill with a maximum thickness of 10mm, such as perspex/plywood. Can be added to an existing structure. Space 450mm apart.

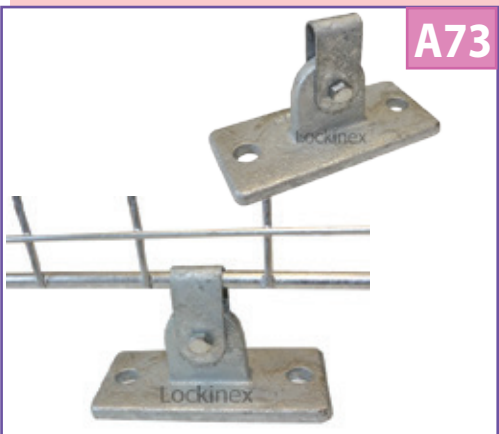

A73

See A50 for plate size.

Used to retain mesh panels to the floor. Position at no more than 450mm apart.

A74-6mm Socket



A74-8mm Socket



A74-Ratchet



A76 Allen Key



Allen key available in two sizes (6mm and 8mm).

Gradient Range

G01

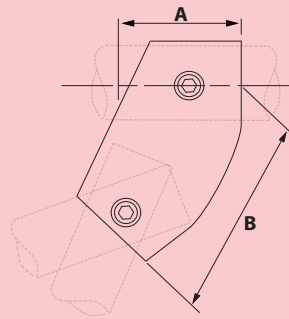
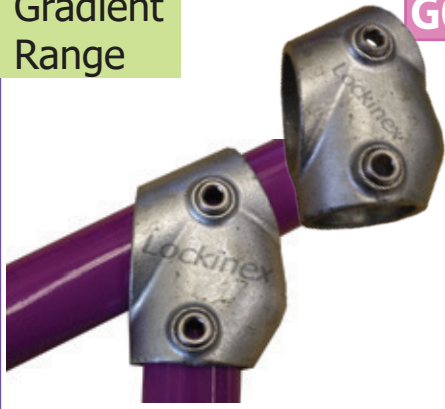

Tube size

- 6 (B)=33.7mm dia.
- 7 (C)=42.4mm dia.
- 8 (D)=48.3mm dia.

| A | B | | | | |
|----|-----|---|---|---|---|
| 54 | 74 | - | - | - | - |
| 64 | 89 | - | - | - | - |
| 68 | 102 | - | - | - | - |

Variable angle clamp, tubes can be connected between angles of 30 to 60 degrees. Use for an angled top rail joint to vertical post on stairs. Used in conjunction with A23 for the lower rail(s). Can be used for diagonal braces for racking etc.

Gradient Range

G02

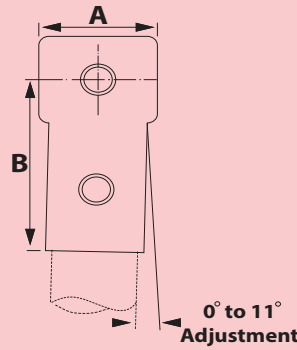

Tube size

- 6 (B)=33.7mm dia.
- 7 (C)=42.4mm dia.
- 8 (D)=48.3mm dia.

| A | B | C | D | E | F |
|----|----|---|---|---|---|
| - | - | - | - | - | - |
| 57 | 46 | - | - | - | - |
| 68 | 60 | - | - | - | - |
| 68 | 64 | - | - | - | - |
| - | - | - | - | - | - |

Used for the joint between the end post and the lower rail(s). Also can be used for the top 'T' joint. Tube cannot be joined in the top part of the 'T' use the G4 when this is required.

Gradient Range

G03

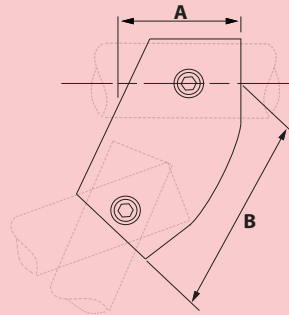

Tube size

- 7 (C)=42.4mm dia.
- 8 (D)=48.3mm dia.

| A | B | | | | |
|-----|-----|---|---|---|---|
| - | - | - | - | - | - |
| N/A | N/A | - | - | - | - |
| N/A | N/A | - | - | - | - |
| - | - | - | - | - | - |

Variable angle clamp, tubes can be connected between angles of 11 to 30 degrees. Use for an angled top rail joint to vertical post on stairs. Used in conjunction with G23 for the lower rail(s). Can be used for diagonal braces for racking etc.

Gradient Range

G04

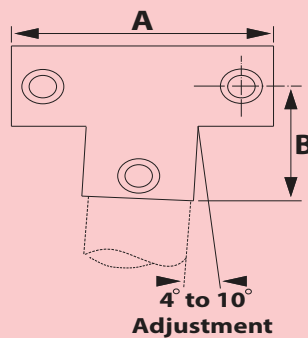

Tube size

- 6 (B)=33.7mm dia.
- 7 (C)=42.4mm dia.
- 8 (D)=48.3mm dia.

| A | B | | | | |
|-----|----|---|---|---|---|
| - | - | - | - | - | - |
| 103 | 45 | - | - | - | - |
| 144 | 60 | - | - | - | - |
| 144 | 76 | - | - | - | - |
| - | - | - | - | - | - |

Used for the joint between the top rail rail and vertical post. Allows tubes to be joined in the top part of the 'T'. Use the G22 to compliment this for the lower rail(s).

Gradient Range

G05

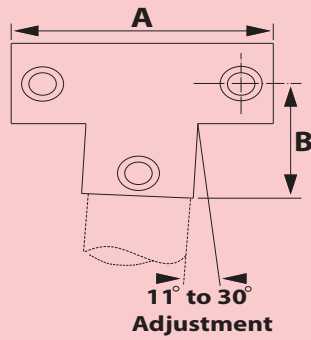

Tube size

A B

7 (C)=42.4mm dia.

8 (D)=48.3mm dia.

| | | | | |
|-----|-----|---|---|---|
| - | - | - | - | - |
| - | - | - | - | - |
| N/A | N/A | - | - | - |
| N/A | N/A | - | - | - |
| - | - | - | - | - |

Used for the joint between the top rail rail and vertical post. Allows tubes to be joined in the top part of the 'T'. Use the G23 or A46 to compliment this for the lower rail(s).

Gradient Range

G07

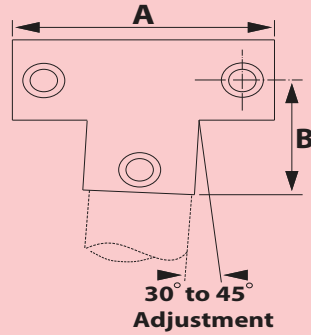

Tube size

A B

7 (C)=42.4mm dia.

8 (D)=48.3mm dia.

| | | | | |
|-----|-----|---|---|---|
| - | - | - | - | - |
| - | - | - | - | - |
| N/A | N/A | - | - | - |
| N/A | N/A | - | - | - |
| - | - | - | - | - |

Used for the joint between the top rail rail and vertical post. Allows tubes to be joined in the top part of the 'T'. Use the G24 or A46 to compliment this for the lower rail(s).

Gradient Range

G06

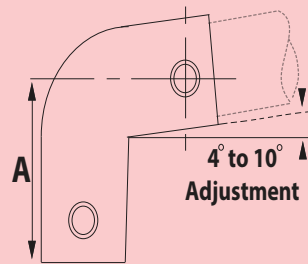

Tube size

A B C D E F

6 (B)=33.7mm dia.

7 (C)=42.4mm dia.

8 (D)=48.3mm dia.

| | | | | | |
|----|---|---|---|---|---|
| - | - | - | - | - | - |
| 34 | - | - | - | - | - |
| 48 | - | - | - | - | - |
| 68 | - | - | - | - | - |
| - | - | - | - | - | - |

Used for the termination of the top rail to the vertical post at the starting point of the incline.

Gradient Range

G08

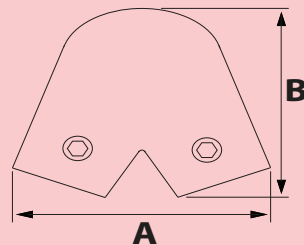

Tube size

A B

8 (D)=48.3mm dia.

| | | | |
|-----|-----|---|---|
| - | - | - | - |
| - | - | - | - |
| - | - | - | - |
| 160 | 125 | - | - |
| - | - | - | - |

Two tubes can be joined to create an incline of 11-30 degrees . Joins the angled rail from a ramp or steps to a vertical post on a landing. Starts an angled rail from top of a first post.

Gradient Range

G09

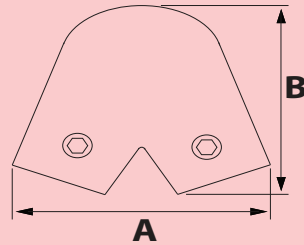

Tube size

A B

8 (D)=48.3mm dia.

| | | | | | |
|-----|-----|---|---|---|---|
| - | - | - | - | - | - |
| - | - | - | - | - | - |
| - | - | - | - | - | - |
| 160 | 125 | - | - | - | - |
| - | - | - | - | - | - |

Two tubes can be joined to create an incline of 30-45 degrees. Joins the angled rail from a ramp or steps to a vertical post on a landing. Starts an angled rail from top of a first post.

Gradient Range

G10

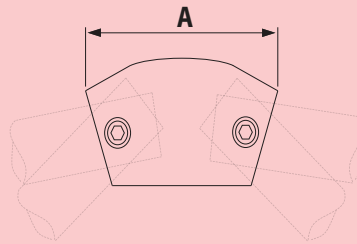
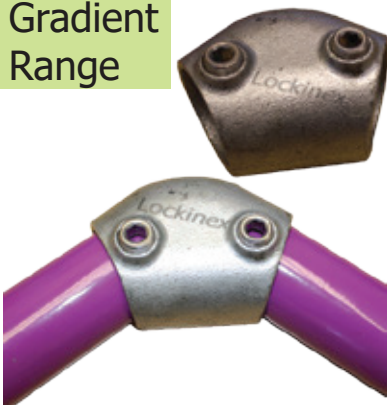

Tube size

A B C D E F

6 (B)=33.7mm dia.

7 (C)=42.4mm dia.

8 (D)=48.3mm dia.

| | | | | | |
|-----|---|---|---|---|---|
| - | - | - | - | - | - |
| 90 | - | - | - | - | - |
| 106 | - | - | - | - | - |
| 120 | - | - | - | - | - |
| - | - | - | - | - | - |

Two tubes can be joined with an angle range between 15-60 degrees. Joins the angled rail from a ramp or steps to level rails on a landing. Starts an angled rail from top of a first post. Can be used for obtuse angle change in a handrail.

Gradient Range

G11

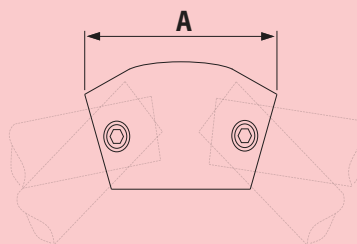

Tube size

A B C D E F

6 (B)=33.7mm dia.

7 (C)=42.4mm dia.

8 (D)=48.3mm dia.

| | | | | | |
|-----|---|---|---|---|---|
| - | - | - | - | - | - |
| 90 | - | - | - | - | - |
| 106 | - | - | - | - | - |
| 120 | - | - | - | - | - |
| - | - | - | - | - | - |

Two tubes can be joined with an angle range between 11-30 degrees. Joins the angled rail from a ramp or steps to level rails on a landing. Starts an angled rail from top of a first post. Can be used for obtuse angle change in a handrail.

Gradient Range

G12

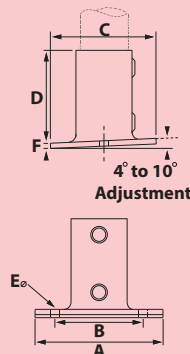
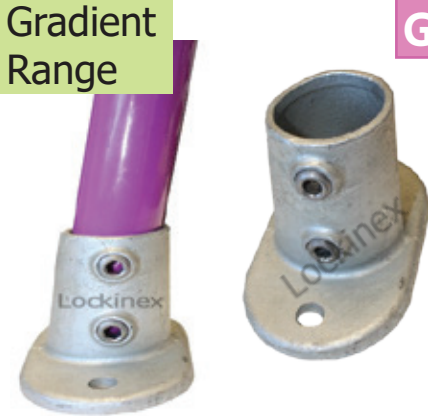

Tube size

A B C D E F

6 (B)=33.7mm dia.

7 (C)=42.4mm dia.

8 (D)=48.3mm dia.

| | | | | | |
|-----|-----|----|----|----|----|
| - | - | - | - | - | - |
| 126 | 88 | 80 | 82 | 14 | 8 |
| 138 | 102 | 90 | 88 | 14 | 8 |
| 150 | 112 | 92 | 88 | 14 | 10 |
| - | - | - | - | - | - |

Provides a structural base plate for the vertical post. Due to the design, this base plate can only be fixed down with the fixing holes in line with the applied load (i.e. 90° to the rails).

Gradient Range

G13

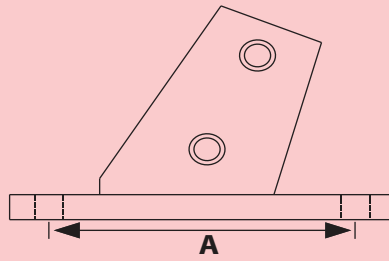

Tube size

A

7 (C)=42.4mm dia.

8 (D)=48.3mm dia.

| | | | | | |
|-----|---|---|---|---|---|
| - | - | - | - | - | - |
| - | - | - | - | - | - |
| 106 | - | - | - | - | - |
| N/A | - | - | - | - | - |
| - | - | - | - | - | - |

Provides a structural base plate for the vertical post. Allows 11-30 degree incline. Due to the design, this base plate can only be fixed down with the fixing holes perpendicular to the applied load (i.e in line with the rails).
 **Procure product prior to pre-drilling holes in structures as some dimensions may vary.

Gradient Range

G14

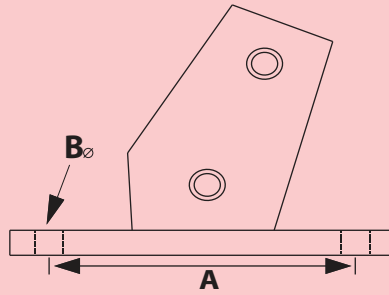

Tube size

A

7 (C)=42.4mm dia.

8 (D)=48.3mm dia.

| | | | | | |
|-----|-----|---|---|---|---|
| - | - | - | - | - | - |
| - | - | - | - | - | - |
| N/A | N/A | - | - | - | - |
| 125 | 18 | - | - | - | - |
| - | - | - | - | - | - |

Provides a structural base plate for the vertical post. Allows 30-45 degree incline. Due to the design, this base plate can only be fixed down with the fixing holes perpendicular to the applied load (i.e in line with the rails).
 **Procure product prior to pre-drilling holes in structures as some dimensions may vary.

Gradient Range

G15

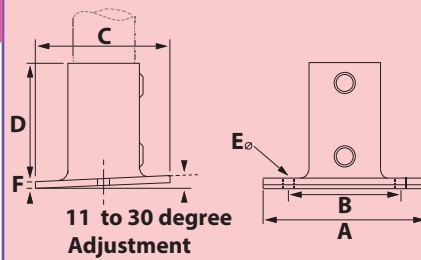

Tube size

A B C D E F

7 (D)=42.4mm dia.

8 (D)=48.3mm dia.

| | | | | | |
|-----|-----|-----|-----|-----|-----|
| - | - | - | - | - | - |
| - | - | - | - | - | - |
| N/A | N/A | N/A | N/A | N/A | N/A |
| 165 | 127 | 95 | 100 | 18 | 12 |
| - | - | - | - | - | - |

Provides a structural base plate for the vertical post. Due to the design, this base plate can only be fixed down with the fixing holes in line with the applied load (i.e. 90 to the rails).
 **Procure product prior to pre-drilling holes in structures as some dimensions may vary.

Gradient Range

G22

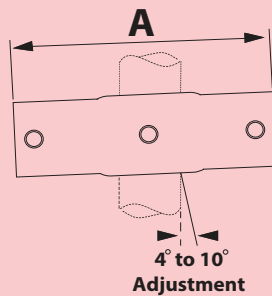

Tube size

A B C D E F

6 (B)=33.7mm dia.

7 (C)=42.4mm dia.

8 (D)=48.3mm dia.

| | | | | | |
|-----|---|---|---|---|---|
| - | - | - | - | - | - |
| 108 | - | - | - | - | - |
| 140 | - | - | - | - | - |
| 144 | - | - | - | - | - |
| - | - | - | - | - | - |

Used for the connection of lower rail(s) to an intermediate vertical post, the vertical post must remain continuous while the rails are joined in each side of the clamp. Complimented with the G4 for the top rail connection.

Gradient Range

G30



Tube size

7 (C)=42.4mm dia.

8 (D)=48.3mm dia.

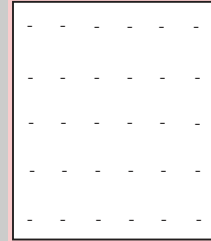

90 degree corner + 30 - 45 degree incline outlet. Used to form a right hand side outlet where the top rail changes from level to sloping.

Gradient Range

G32



Tube size

7 (C)=42.4mm dia.

8 (D)=48.3mm dia.

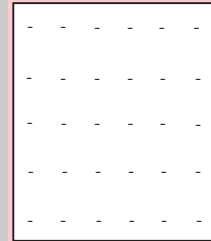

90 degree corner + 30 - 45 degree incline outlet. Used to form a right hand side outlet where the mid rail changes from level to sloping.

Gradient Range

G34



Tube size

7 (C)=42.4mm dia.

8 (D)=48.3mm dia.

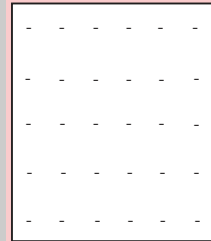

90 degree corner + 30 - 45 degree incline outlet. Used to form an outlet where the top rail changes from level to sloping. Consider the A25 as a cheaper alternative.

Gradient Range

G36



Tube size

7 (C)=42.4mm dia.

8 (D)=48.3mm dia.

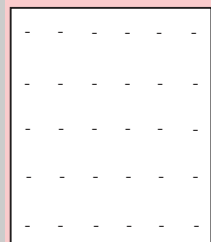

90 degree corner + 30 - 45 degree incline outlet. Used to form an outlet where the top rail changes from level to sloping. Consider the A25 as a cheaper alternative.

Gradient Range

G38



Tube size

7 (C)=42.4mm dia.

8 (D)=48.3mm dia.

| | | | | |
|---|---|---|---|---|
| - | - | - | - | - |
| - | - | - | - | - |
| - | - | - | - | - |
| - | - | - | - | - |
| - | - | - | - | - |
| - | - | - | - | - |
| - | - | - | - | - |
| - | - | - | - | - |
| - | - | - | - | - |
| - | - | - | - | - |

90 degree corner + 30 - 45 degree incline outlet. Used to form an outlet where the mid rail changes from level to sloping. Consider the A27 as a cheaper alternative.

Gradient Range

J99



Tube size

8 (D)=48.3mm dia.

| | | | | |
|---|---|---|---|---|
| - | - | - | - | - |
| - | - | - | - | - |
| - | - | - | - | - |
| - | - | - | - | - |
| - | - | - | - | - |
| - | - | - | - | - |
| - | - | - | - | - |
| - | - | - | - | - |
| - | - | - | - | - |
| - | - | - | - | - |

Much like the A28. Provides a 90 degree crossover joint. Used in guardrail installations. Rails are passed through in long lengths and joined using the A8 or A9. Due to the open top design, horizontal tube can simply be dropped in and secured rapidly.

Info Snippet

To comply with Building Regulations for Access Ramps serving Public Buildings consider our Ramp Handrail System (DDA Compliant). Details can be found on our web site www.lockinex.com



The pictures show installations of the Lockinex Ramp Handrail System. The "Offset" Handrail is the key feature which complies with current Building Regulations.

Guidelines for loading details.

Guardrails & Handrails Key Clamp Load Chart

Notes

360 Newtons per metre run (N/m) Industrial use-non emergency
 740 Newtons per metre run (N/m) Commercial use
 1500 Newtons per metre run (N/m) Retail/public access
 These loads are as specified in BS 6180:2011
 All tube is manufactured to BS EN 10255.

Horizontal rails are the same diameter as the upright posts and manufactured to BS EN 10255.

The table is based on the maximum permissible bending moment of the tube.

The figures shown in brackets are the required anchor pull out loads for the bay size indicated after all reduction factors have been applied.

Design loads stated in BS 6180:2011, BS 7818, BS 4592-0:2006+A1:2012 & BS EN ISO 14122-3:2001.

The bay sizes are based on using the Lockinex A-12 base plate which is fixed with the fixing down bolts in line with the applied load.

| Tube Size | Size 6 (Wall Thickness 3.2mm) | Size 7 (Wall Thickness 3.2mm) | Size 7 (Wall Thickness 4mm) | Size 8 (Wall Thickness 3.2mm) | Size 8 (Wall Thickness 4mm) | Size 8 (Wall Thickness 5mm) | Size 9 (Wall Thickness 3.6mm) | Size 9 (Wall Thickness 4.5mm) |
|----------------------|--|--|--------------------------------------|--|--------------------------------------|--------------------------------------|--|--|
| Design Load Criteria | Upright Height 900mm | | | | | | | |
| 360 N/m | 815mm (4.44kN) | 1368mm (6.52kN) | 1596mm (7.60kN) | 1826mm (7.73kN) | 2583mm (10.92kN) | 3051mm (12.90kN) | 3266mm (13.8kN) | 3855mm (14.75kN) |
| 740 N/m | 396mm (4.44kN) | 667mm (6.52kN) | 777mm (7.60kN) | 890mm (7.73kN) | 1256mm (10.92kN) | 2230mm (19.36kN) | 1587mm (13.8kN) | 1875mm (14.75kN) |
| 1500 N/m | 194mm (4.44kN) | 330mm (6.52kN) | 382mm (7.60kN) | 438mm (7.73kN) | 621mm (10.92kN) | 1099mm (19.36kN) | 785mm (13.8kN) | 924mm (14.75kN) |
| Design Load Criteria | Upright Height 1000mm | | | | | | | |
| 360 N/m | 733mm (4.44kN) | 1231mm (6.52kN) | 1434mm (7.60kN) | 1646mm (7.73kN) | 2327mm (10.92kN) | 2931mm (13.76kN) | 2938mm (13.8kN) | 3471mm (14.75kN) |
| 740 N/m | 358mm (4.44kN) | 598mm (6.52kN) | 699mm (7.60kN) | 802mm (7.73kN) | 1132mm (10.92kN) | 2005mm (19.36kN) | 1431mm (13.8kN) | 1689mm (14.75kN) |
| 1500 N/m | 177mm (4.44kN) | 295mm (6.52kN) | 346mm (7.60kN) | 394mm (7.73kN) | 559mm (10.92kN) | 991mm (19.36kN) | 704mm (13.8kN) | 832mm (14.75kN) |
| Design Load Criteria | Upright Height 1100mm | | | | | | | |
| 360 N/m | 667mm (4.44kN) | 1121mm (6.52kN) | 1304mm (7.60kN) | 1495mm (7.73kN) | 2115mm (10.92kN) | 2777mm (14.35kN) | 2672mm (13.8kN) | 3156mm (14.75kN) |
| 740 N/m | 326mm (4.44kN) | 546mm (6.52kN) | 636mm (7.60kN) | 727mm (7.73kN) | 1027mm (10.92kN) | 1823mm (19.36kN) | 1299mm (13.8kN) | 1536mm (14.75kN) |
| 1500 N/m | 162mm (4.44kN) | 268mm (6.52kN) | 312mm (7.60kN) | 358mm (7.73kN) | 508mm (10.92kN) | 899mm (19.36kN) | 640mm (13.8kN) | 758mm (14.75kN) |

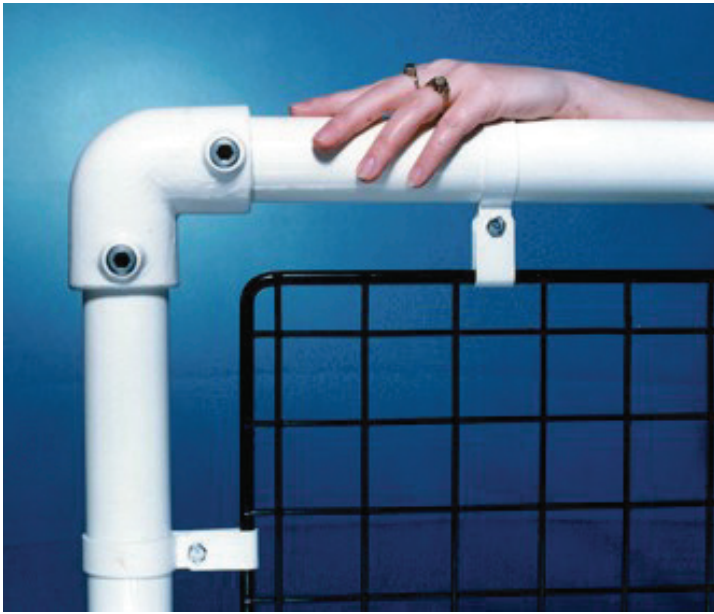

Composition, manufacture

Every clamp is subjected to a heat treatment process that gives the clamps their malleability and inherent strength. Once this process is completed the clamps are then shot blasted to provide a clean surface which is free from burrs and sharp edges. The clamps are then galvanised to BS EN 1461:2009 to ensure that they resist corrosion and will provide a strong durable joint for many years ahead. All clamps are supplied completely rust proofed and extra strong case hardened allen screws. Clamps and tubing can also be supplied polyester powder coated from a wide range of assorted colours.

Dimensions

Dimensions are given for each type of clamp on the preceding pages. They are supplied in a range of sizes suitable for tubes from 26.9mm to 60.3mm outside diameter.

Design Considerations

When tightened to 4.1kg (29 ft/lb) a slip load of 900 kg can be obtained on each screw.

Additional clamps can be installed directly under the initial load bearing clamp to increase loading capacity further. The ratchet spanner (Ref A74) should be used to tighten the screws to the required torque.

SITWORK

Installation

Our Lockinex Key Clamps are fast and easy to erect, they need no special skills or tools. Tube bending can be eliminated by use of the varied and flexible range of clamps that are available. The positive locking of the allen screw gives rigid quickly made connections which, if required, allow for easy dismantling or modifications. Where access could be difficult for a fabricated structure the fittings and tubing can be packed for easy conveyance to the most difficult locations.

SUPPLY

Availability Direct from the company

Delivery A complete nationwide service is provided

SERVICES

Design and estimating

A complete service, including calculations, where necessary, is available to comply with the requirements of British Standards and Health & Safety Executive recommendations.

Please contact our design department for any advice you may require.

Sales and technical

Please contact the company at the address shown