

ML52-READER RFID CAM LOCK

Installation Instructions - ML52-READER

Programming locks is recommended prior to installation. Refer to Operating Instructions.

Package Contents:

- A. 2 x RFID cards
- B. 1 x ML52-READER lock
- C. 1 x Rubber gasket
- D. 1 x Rubber ring washer
- E. 1 x M16 nut
- F. 1 x Cam governor (limits cam to 90°)
- G. 2 x Cams (1 flat, 1 offset)
- H. 2 x M4 washer
- I. 1 x Cam fixing bolt - M4 x 10mm
- J. 4 x Upper lock fixing bolt options to suit door thicknesses;
 - 1-3mm doors - M4 x 10mm
 - 3-13mm doors - M4 x 20mm
 - 13-18mm doors - M4 x 25mm
 - 18-23mm doors - M4 x 30mm

⚠ Caution:

Once batteries are installed, the first card to touch the lock will automatically be set as the Administration Card. See operating instructions for card programming.

- Use Alkaline AAA batteries ONLY (Using other battery types may cause damage)
- Dispose of used batteries according to the batteries instructions

Power:

3 x AAA Alkaline batteries
(NOT INCLUDED IN PACK)

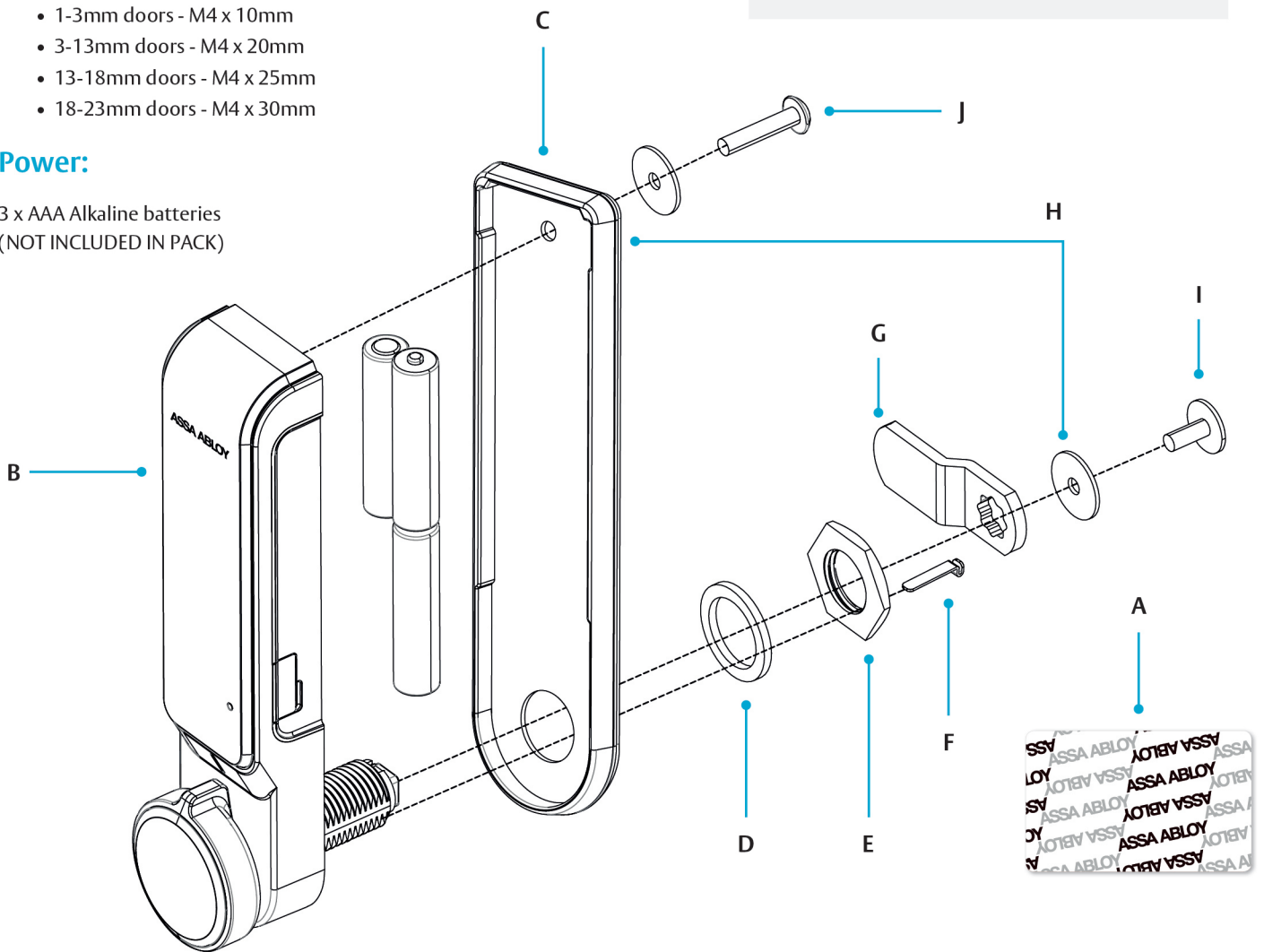

Installation Template

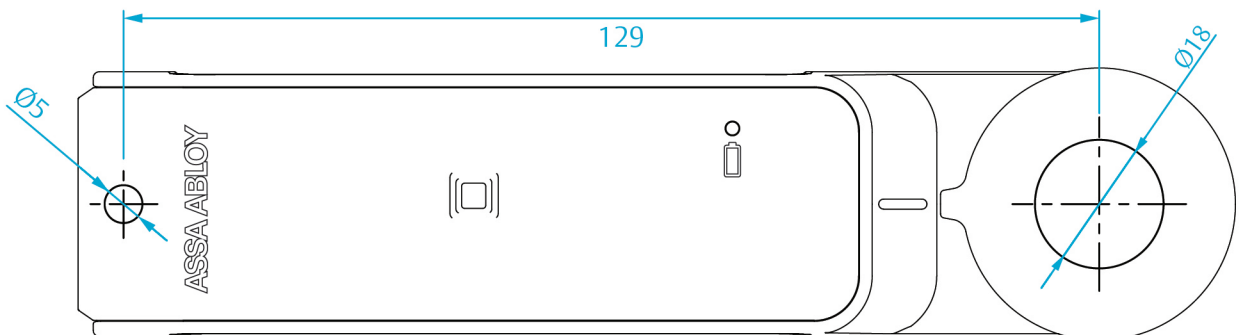

Installation:

1. Position the template on the door in the required vertical or horizontal position

Position Notes:

- Ensure the lock position allows the cam to move freely between the locked and unlocked position
- Ensure the chosen cam (flat or offset) will securely fasten the door in the locked position

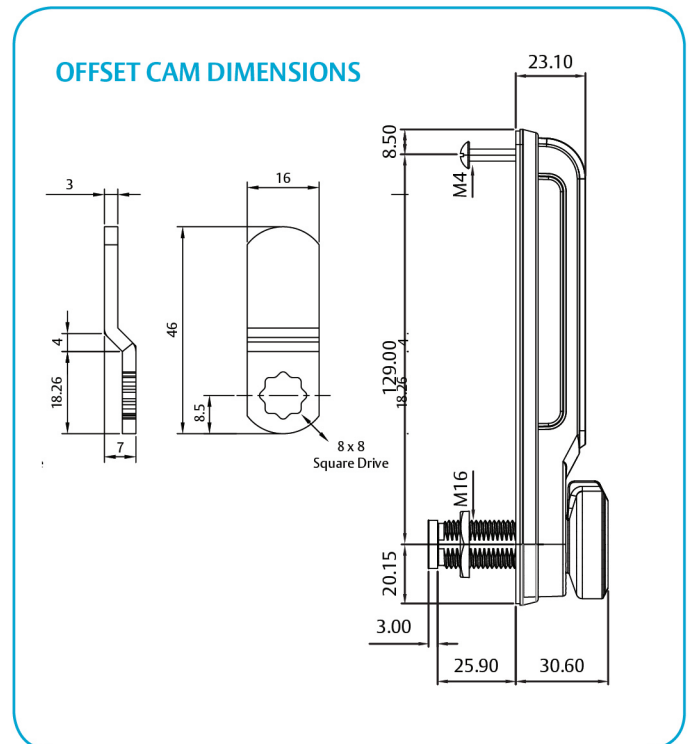
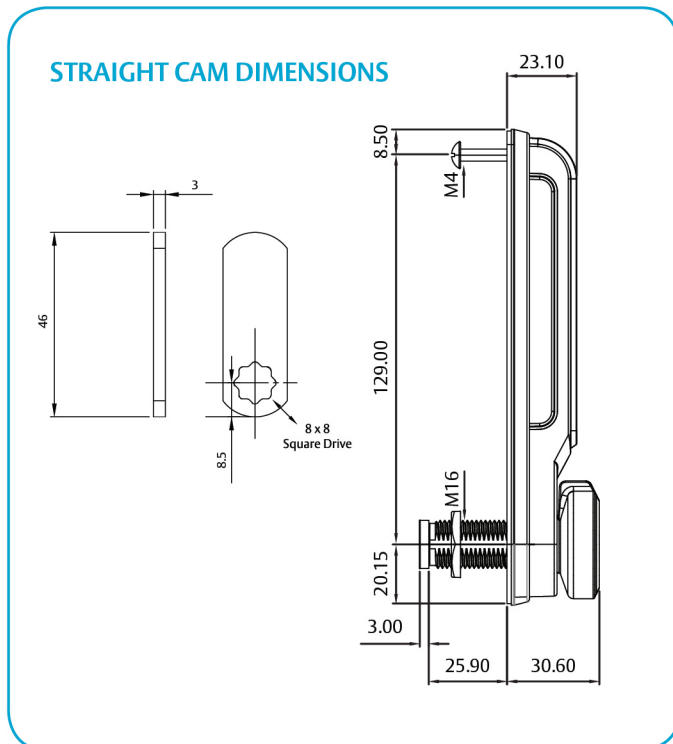

2. Drill the upper lock fixing bolt hole with a 5mm drill bit
3. Drill the cam lock hole with a 18mm drill bit
4. Install 3 x alkaline AAA lock batteries (not included in pack)
5. Fit rubber gasket (C) to the lock (B)
6. Choose the correct upper M4 bolt (J) for the door thickness. Position the lock to the door and fix the upper lock bolt with M4 washer (H)
7. Install the rubber ring washer (D)
8. Fix lock with M16 nut (E)

9. This step is only required if you need to limit the cam motion to 90°. Insert the cam governor (F) into one of the two holes at the end of the cam lock. Choose the hole that will limit the cam in the direction that suits your application.

10. Install cam (G), M4 washer (H) and M4 x 10mm cam fixing bolt (I)

11. Test lock securely locks door

12. Proceed with operating instructions

Note: Test lock with the door open.

ML52-READER RFID CAM LOCK

Operating Instructions - ML52-READER

Preparation Notes

- Programming your locks is best done before you install the locks.
- Don't touch any card to the locks until you are ready to start programming.
- Have all cards ready when you begin programming the locks.
- In these instructions: "touch" = a short touch for the lock to register the card only.
- "hold" = hold the card to the lock for the specified visual and audible signals.

Operating Modes

The ML52-READER has two operating modes, by default the lock is factory set to **Private Mode**. The modes can be changed after setting the Administration Card in the section below.

- In **Private Mode** permanent User Cards can be set. This is best for individually allocated lockers. Locks in Private Mode will automatically lock after 3 seconds.
- In **Public Mode** a temporary User Card is set. This is best for shared lockers. A lock will only lock after a User Card is touched to the lock.

Setting the Administration & Master Cards

Note: Setting Master Cards Mode starts automatically after programming Administration Cards. If you miss this step go to section "How to Change Master Cards" on page 2.

Admin

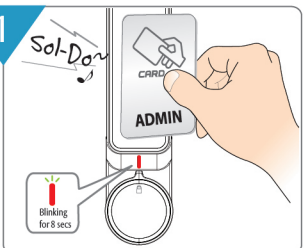

- 1** Touch a card to register it as an Admin Card - Red LED blinks for 8 secs with melody sound "Sol-Do~"

Note: The first registered Admin Card should be marked "1st Admin" card and kept in a safe place. Only this card can be used to change operating modes

- b** During the 8 sec of red LED flashing from point "a" an additional 19 cards may be touched in sequence to program a maximum of 20 Admin Cards
- c** Touch the same card twice to stop Admin Card setting mode. The red LED will stop blinking and the orange LED will start blinking to indicate the lock is now in Master Card setting mode

Master

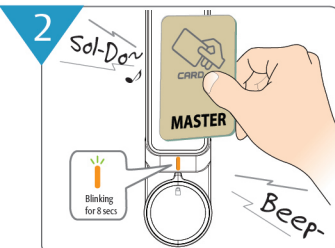

- 2** After Admin Card setting mode, Master Card setting mode starts automatically
- d** Touch another card up to 20 in sequence for setting up to 20 Master Cards
- e** Touch same card twice to stop Master Card setting mode

Note: Skip Master Card setting mode if you do not want to register a Master Card or delete a previous Master Card

Cards

- Cards are not factory programmed to any card type, Administration, Master or User.
- Administration Card (Admin)** – This is used to perform all programming functions. Up to 20 can be programmed to each lock.
 - Note:** -Only the first Administration Card set can be used to change operating modes.
 - Any time an Administration Card is used it will clear all User Cards.
 - Master Card** – This is used to open locks. Up to 20 can be programmed to each lock.
 - Note:** -Master Cards can only be used in Private Mode.
 - Be aware Master Cards can be used without trace even if the cabinet is in use.
 - User Card** – This is used for unlocking locks. In Public Mode it will also lock locks.

How to Switch Between Private & Public Mode

Step 1

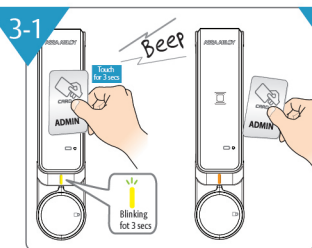

- 3-1** Hold "1st" Admin Card for 3 seconds until a short beep. Remove the card after the short beep. Note: Default Mode is Private Mode

Note: Changing back to Private Mode can be done by following point "a" in this section

Note: If user cards are already programmed you will need to first delete all user cards by touching any Admin Card. Both LEDs will blink orange 5 times

Step 2

b-1 Public Mode



Blinking 1 time

b-2 Private Mode



Blinking 3 times

- b-1** **Public Mode**
The LED will blink orange 2 times with melody sound "Beep-" to indicate the lock is now in Public Mode
- b-2** **Private Mode**
The LED will blink orange 3 times with melody sound "Sol-Do~"

Setting User Card

Private Mode

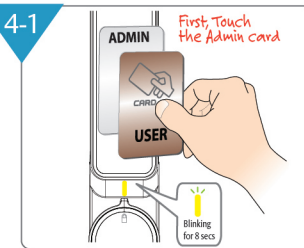

- 4-1** Touch any Admin Card (Yellow LED blinks for 8 seconds)
- b** Touch a card to set the card as a User. (Up to 20 User Cards can be registered)
- c** Touch same card twice to stop the User Card setting mode

Public Mode

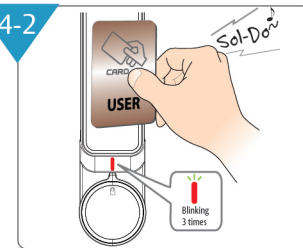

- 4-2** Touch any User Card Red LED blinks 3 times with melody sound "Sol-Do~"

Private Mode - How to Use the User Card

Unlock the Door

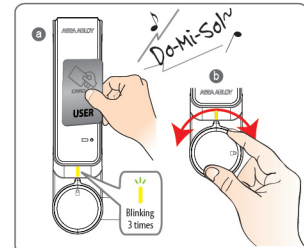

- a** Touch a registered User Card. Yellow LED blinks 3 times with melody sound "Do-Mi-Sol~"
- b** Turn the handle to the open position and open the door

Lock the Door

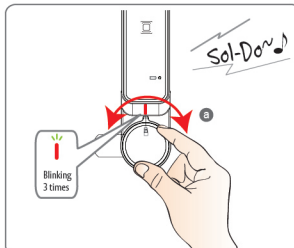

- a** Close the door and turn the handle to the lock position

Note: Private Mode (Assigned use) - The lock will automatically lock in 3 seconds, just close the door and turn the handle to the lock position

Changing User Card

- a** Touch any Admin Card to delete all User Cards.
- b** Repeat steps 4-1 or 4-2 to reprogram User Cards

ML52-READER RFID CAM LOCK

Operating Instructions - ML52-READER

Public Mode - How to Use the User Card

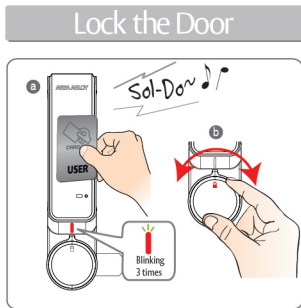

- a Touch the User Card. Red LED blinks 3 times with melody sound "Sol-Do~"
- b Turn the handle to the lock position

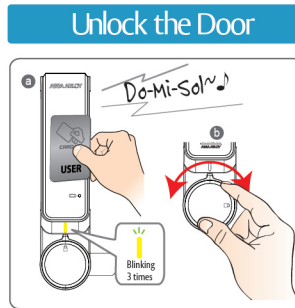

- a Touch the User Card. Yellow LED blinks 3 times with melody sound "Do-Mi-Sol~"
- b Turn the handle to the open position and open the door

Note: Public Mode (One Time use) - User Card will be erased after being unlocked and stay open for next user

How to Change the Administration Cards

Note: This process will delete any existing Administration Cards and User Cards.

Step 1

a Touch any Admin Card to delete User Cards

Step 2

b Hold any Admin Card for 10 seconds. The lock will beep after three seconds and after 10 seconds will give 3 beeps. After 3 beeps remove card

Step 3

c LED will flash red for 8 secs to indicate Admin Card setting mode

Step 4

d Touch up to 20 cards in sequence during red flashing to set Admin Cards

Step 5

e Touch the Admin Card twice to stop setting of the Admin Card

Step 6

f The Admin Card change is complete

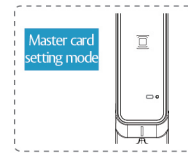

Note: Master programming mode will begin automatically after step 5. This is indicated by the LED flashing orange for 8 secs.

How to Change the Master Cards

Note: This process will delete any existing Master Cards and User Cards.

Step 1

a Touch any Admin Card to delete User Cards

Step 2

b Hold any Admin Card for 10 seconds. The lock will beep after three seconds and after 10 seconds will give 3 beeps. After 3 beeps remove card

Step 3

c Wait while LED flashes red for 8 secs and gives single beep

Step 4

d LED will flash orange for 8 secs to indicate Master Card setting mode

Step 5

e Touch up to 20 cards in sequence during orange flashing to set new Master Cards

Step 6

f Touch last Master Card twice to stop Master Card setting mode

Step 7

g The Master Card change is complete

External Emergency Power

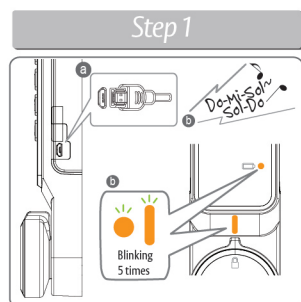

- a Connect standard 5 pin Micro USB cable to the USB Port on the right side of the lock
- b When power is applied, both LEDs blink 5 times with melody sound "Do-Mi-Sol~Sol-Do"

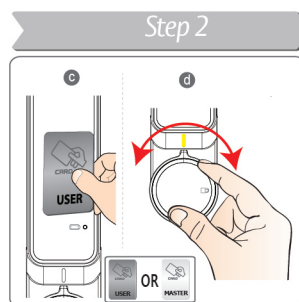

- c Touch a User Card or Admin Card to unlock
- d Open the door and change all 3 batteries

Note: - The User Card will be deleted after use of the Admin Card
- For Private Mode the User Cards will need to be reprogrammed

Hard Reset

On the rear of the lock at the top right of the battery compartment there is a 2mm hole. A small pin can be inserted here and held down for 3 seconds until a beep sounds. This will delete all card types from the lock.

Note: This will not reset the mode back to Private Mode if the lock is in Public Mode.

