

ARCADE 1UP

WIFI
LIVE

- ASSEMBLY INSTRUCTIONS
- MONTERINGS INSTRUKTIONER
- MONTAGE INSTRUCTIES
- KOKOAMISOHJEET
- INSTRUCTIONS DE MONTAGE
- MONTAGEANLEITUNGEN
- SAMANTEKTARLEIÐBEININGAR
- ISTRUZIONI DI MONTAGGIO
- MONTERINGS ANVISNINGER
- INSTRUCCIONES DE MONTAJE
- MONTERINGS ANVISNINGAR
- INSTRUÇÕES DE MONTAGEM



WWW.ARCADE1UP.COM

ADULT ASSEMBLY REQUIRED

INSPECTION & ASSEMBLY:

TO ENSURE A SUCCESSFUL STARTUP FOLLOWING SHIPMENT, THE ARCADE1UP CABINET SHOULD BE INSPECTED BEFORE INITIAL ASSEMBLY AND POWER UP.

- CAREFULLY REMOVE THE GAME CABINET FROM ITS SHIPPING BOX AND INSPECT IT FOR VISIBLE SIGNS OF DAMAGE.

NOTE: IF YOUR GAME EXHIBITS SIGNS OF DAMAGE BE SURE TO DOCUMENT IT AND CONTACT OUR CUSTOMER SERVICE IMMEDIATELY.

KEEP INSTRUCTIONS FOR FUTURE USE
RETAIN FOR FUTURE REFERENCE.

FOR REPLACEMENT PARTS OR TO DISASSEMBLE.
FOLLOW ASSEMBLY INSTRUCTION IN REVERSE.

SAMLING AF EN VOKSEN ER PÅKRÆVER

INSPEKTION OG SAMLING:

FOR AT SIKRE EN KORREKT OPSTART EFTER FORSENDELSEN SKAL ARCADE1UP-KABINETTET INSPIRERES FØR DET SAMLES OG STARTES.

- FJERN FORSIGTIGT SPILKABINETTET FRA FORSENDELSÆSKEN OG INSPIRER DET FOR SYNLIGE TEGN PÅ SKADE.

BEMÆRK: HVIS DITT SPIL UDSTYRER SKADER
TEKNISKE SIKRIG AT DOKUMENTERE DET OG
KONTAKT VORES KUNDESERVICEN ØJEBLIKKELT.

HOLD INSTRUKTIONER TIL FREMTIDIG BRUG
RETANTE FOR FREMTIDIG REFERENCE.

TIL UDSKIFTINGSDELER ELLER TIL UDFORMNING.
FØLG MONTERINGSINSTRUKTION I VENDELSE.

VEREIST MONTAGE DOOR EEN VOLWASSENE

INSPECTIE & MONTAGE:

OM EEN SUCCESVOLLE INBEDRIJFSTELLING NA LEVERING TE GARANDEREN, MOET DE ARCADE1UP-KAST VOOR DE EERSTE MONTAGE EN INBEDRIJFSTELLING WORDEN GEINSPECTEERD.

- VERWIJDER DE SPEELKAST VOORZICHTIG UIT DE DOOS EN CONTROLEER DEZE OP ZICHTBARE BESCHADIGINGEN.

OPMERKING: ALS UW SPEL TEKENEN VAN SCHADE TOONT, ZORG ERVOOR DAT U HET DOCUMENT EN ONMIDDELIJK CONTACT OPNEMT MET ONZE KLANTENSERVICE.

BEWAAR INSTRUCTIES VOOR TOEKOMSTIG GEBRUIK
BEHOUD VOOR TOEKOMSTIGE REFERENTIE.

VOOR VERVANGINGSONDERDELEN OF VOOR DEMONTAGE.
VOLG DE MONTAGE-INSTRUCTIE IN ACHTERUIT.

VAIN AIKUISTEN ASENNETTAVA

TARKASTUS JA KOKOAMINEN:

ONNISTUNEEN KÄYNNISTYMISEN VARMISTRAMINEN TOIMITUKSEN JÄLKEEN EDELLYTTÄÄ ARCADE1UP-KAAPIN TARKASTUSTA ENNEN KOKOAMISTA JA KÄYNNISTÄMISTÄ.

- POISTA KAAPPI VAROAVASTI TOIMITUSPAKKAUKSESTAAN JA TARKASTA, NÄKYKÖ SINÄJÄ MERKKEJÄ VAURIOISTA.

HUOMAUTUS: JOS PELI NÄYTETTÄÄ VAHONGON
MERKIT, VARAA, ETTÄ ASIAKIRJASI JA OTA
VÄLITTÖMÄSTI YHTEYS ASIAKASPALVELUUMME.

SÄILYÄ TULEVAAN KÄYTTÖOHJEITA
TULEVAISEN VIITTEEN RETAIN.
VARAOSSIEN TAI PURKAMISEKSI.
SEURAAVAT ASENNUSOHJEET KÄÄNTÖPUOLELLA.

LE MONTAGE DOIT ÊTRE EFFECTUÉ PAR UN ADULTE

INSPECTION & ASSEMBLAGE:

POUR UNE MISE EN PLACE RÉUSSIE APRÈS L'EXPÉDITION, LA BORNE ARCADE1UP DOIT ÊTRE INSPECTÉE AVANT L'ASSEMBLAGE ET LA MISE SOUS TENSION.

- RETIREZ SOIGNEUSEMENT LA BORNE DE JEU DE L'EMBALLAGE ET REPÉREZ D'ÉVENTUELS SIGNES D'ENDOMMAGEMENT.

REMARQUE: SI VOTRE JEU EXPOSE DES SIGNES DE
DOMMAGES, ASSUREZ-VOUS DE LES DOCUMENTER ET DE
CONTACTER IMMÉDIATEMENT NOTRE SERVICE CLIENT.

CONSERVEZ LES INSTRUCTIONS POUR
UNE UTILISATION FUTURE
CONSERVEZ POUR RÉFÉRENCE FUTURE.

POUR REMPLACEMENT DE PIÈCES OU POUR DÉMONTAGE.
SUIVEZ LES INSTRUCTIONS D'ASSEMBLAGE EN INVERSE.

MONTAGE DURCH EINEN ERWACHSENEN

ÜBERPRÜFUNG UND MONTAGE:

ZUR GEWÄHRLEISTUNG DER ERFOLGREICHEN INBETRIEBNAHME NACH DER LIEFERUNG, SOLLTE DER SPIELAUTOMAT ARCADE1UP VOR BEGINN DER MONTAGE UND NUTZUNG ÜBERPRÜFT WERDEN.

- DEN SPIELAUTOMAT VORSICHTIG AUS DEM VERSANDKARTON ENTFERNEN UND AUF SICHTBARE ANZEICHEN VON SCHÄDEN PRÜFEN.

HINWEIS: WENN IHR SPIEL SCHÄDEN AUSSTELLT,
SICHERSTELLEN SIE ES SOFORT UND KONTAKTIEREN SIE
SOFORT UNSEREN KUNDENSERVICE.

BEWAHREN SIE DIE ANWEISUNGEN FÜR
DEN ZUKÜNFTIGEN GEBRAUCH AUF
BLEIBEN SIE FÜR ZUKÜNFTIGE REFERENZEN.
ZUM ERSETZEN VON TEILEN ODER ZUM ZERLEGEN.
BEFOLGEN SIE DIE MONTAGEANLEITUNG IN RÜCKWÄRTS.

VERÐUR AÐ VERA SETT SAMAN AF FULLORÐNUM

SKOÐUN OG SAMSETNING:

TIL AÐ TRYGGJA RÉTTA GANGSETNINGU EFTIR
AFHENDINGU SKAL SKOÐA ARCADE1UP KASSANN
FYRIR FYRSTU UPPSETNINGU OG GANGSETNINGU.

- TAKIÐ KASSANN VARLEGA ÚR UMBÚÐNUM OG SKOÐIÐ
HVORT SÝNILEGAR SKEMMDIR SÉU Á HONUM.

ATHUGIÐ: EF GILDIN SEM SEM TÆKI SKAÐA AÐ VARA AÐ
SKOÐA ÞAÐ OG SAMBANDA VIÐ ÞJÓNUSTUÞJÓNUSTU.

HALDIÐ LEIÐBEININGUM UM FRAMTÍÐARNOTKUN

HALDIÐ ÁFRAM TIL FRAMTÍÐAR TILVÍSUNAR.
TIL Breytingar hluta eða til að taka í sundur.
FYLGDU SAMKOMULAGSLEIÐBEININGUM Í SNÚNINGI.

DEBE SER MONTADO POR UN ADULTO

INSPECCIÓN Y MONTAJE:

PARA GARANTIZAR UN CORRECTO ARRANQUE DESPUÉS DEL ENVÍO, SE DEBE INSPECCIONAR LA VITRINA DEL ARCADE1UP ANTES DEL MONTAJE Y DEL ARRANQUE INICIAL.

- SACA CON CUIDADO LA VITRINA DEL JUEGO DE SU EMBALAJE E INSPECCIONA EN BUSCA DE SEÑALES VISIBLES DE DAÑO.

NOTA: SI SU JUEGO EXPONE SIGNOS DE DAÑO, ASEGÚRESE DE DOCUMENTARLO Y CONTACTAR CON NUESTRO SERVICIO AL CLIENTE INMEDIATAMENTE.

CONSERVE LAS INSTRUCCIONES PARA USO FUTURO
CONSERVAR PARA FUTURAS REFERENCIAS.

PARA PIEZAS DE REPUESTO O PARA DESMONTAJE.
SIGA LAS INSTRUCCIONES DE MONTAJE AL REVERSO.

IL MONTAGGIO RICHIEDE LA PRESENZA DI UN ADULTO

ISPEZIONE E MONTAGGIO:

PER GARANTIRE UNA MESSA IN SERVIZIO CORRETTA DOPO LA SPEDIZIONE, IL VIDEOGIOCO ARCADE1UP DEVE ESSERE ISPEZIONATO PRIMA DEL MONTAGGIO INIZIALE E DELL'ACCENSIONE.

- RIMUOVERE CON ATTENZIONE IL VIDEOGIOCO DAL RELATIVO IMBALLO DI SPEDIZIONE E ISPEZIONARLO PER VERIFICARE L'ASSENZA DI SEGNI VISIBILI DI DANNI.

NOTA: SE IL TUO GIOCO ESPORTA SEGNI DI DANNI ASSICURARSI
DI DOCUMENTARLO E CONTATTARE IMMEDIATAMENTE IL
NOSTRO SERVIZIO CLIENTI.

CONSERVARE LE ISTRUZIONI PER L'UTILIZZO FUTURO

PRENOTAZIONE PER FUTURO RIFERIMENTO.

PER PARTI DI RICAMBIO O DA SMONTARE.

SEGUIRE LE ISTRUZIONI DI MONTAGGIO IN INVERSIONE.

MONTERING SKAL GJØRES AV EN VOKSEN

INSPEKSJON & MONTERING:

FOR Å SIKRE EN VELLYKKET OPPSTART EFTER FORSENDELSE,
BØR ARCADE1UP-KABINETTET INSPIRERES FØR DET
MONTERES OG STARTES FOR FØRSTE GANG.

- TA SPILLKABINETTET FORSIKTIG UT AV FRAKTESKEN
OG SE EFTER TYDELIGE TEGN PÅ SKADE.

MERKNAD: HVIS DITT SPILL UTSTILLER TILTAK FOR SKADER
VÆR SIKRIG DOKUMENTER DET OG KONTAKT VÅRE
KUNDESERVICEN UMIDDELBART.

HOLD INSTRUKSJONER FOR FREMTIDIG BRUK

KJENTE TIL FREMTIDIG REFERANSE.

FOR UTSKIFTINGSDELER ELLER TIL DEMONTERING.

FØLG MONTERINGSINSTRUKSJONEN I REVERSJON.

MONTERING AV VUXEN KRÄVS

INSPEKTION & MONTERING:

FÖR ATT SÄKERSTÄLLA EN LYCKAD START EFTER
LEVERANS BÖR ARCADE1UP-KABINETTET INSPEKTERAS
INNAN MONTERING OCH INKOPPLING.

- TA FÖRSIKTIGT UT SPELKABINETTET UR TRANSPORTLÅDAN
OCH INSPEKTERA DET FÖR TECKEN PÅ SYNLIGA SKADOR.

OBS: OM DITT SPEL UTSTÄLLAR SKADOR TEKNISKE
SÄKER ATT DOKUMENTERA DET OCH KONTAKTA
VÅRA KUNDSTJÄNST OMEDELBART.

HÅLL INSTRUKTIONER FÖR FRAMTIDA ANVÄNDNING
KONTROLLERA FÖR FRAMTIDSREFERENS.

FÖR BYTESDELAR ELLER FÖR DEMONTERING.

FÖLJ MONTERINGSINSTRUKTIONEN I ÖMVÄNDNING.

ASSEMBLÉIA DE ADULTOS NECESSÁRIA

INSPEÇÃO E MONTAGEM:

PARA GARANTIR UMA INICIAÇÃO DE SUCESSO APÓS A EXPEDIÇÃO, O
ARMÁRIO ARCADE1UP DEVE SER INSPECCIONADO ANTES DA
MONTAGEM INICIAL E DA ALIMENTAÇÃO ELÉTRICA.

- REMOVA CUIDADOSAMENTE O GABINETE DO JOGO DA SUA CAIXA DE
TRANSPORTE E INSPECTE-O PARA SINAIS VISÍVEIS DE DANOS.

OBSERVAÇÃO: SE O SEU JOGO EXIBIR SINAIS DE DANOS,
CERTIFIQUE-SE DE DOCUMENTÁ-LO E ENTRAR EM CONTATO
COM O SERVIÇO DE ATENDIMENTO AO CLIENTE IMEDIATAMENTE.

MANTENHA AS INSTRUÇÕES PARA O USO FUTURO
RETENÇÃO PARA FUTURA REFERÊNCIA.

PARA PEÇAS DE SUBSTITUIÇÃO OU DESMONTAGEM.

SIGA AS INSTRUÇÕES DE MONTAGEM EM REVERSA.

- TOOLS NEEDED
- VÆRKTØJER NØDVENDIGT
- GEREEDSCHAP NODIG
- TARVITETTAVAT TYÖKALUT
- OUTILS NÉCESSAIRES
- WERKZEUGE BENÖTIGT
- VERKEFNI ÞÖRF
- STRUMENTI NECESSARI
- VERKTØY NØDVENDIG
- HERRAMIENTAS NECESARIAS
- VERKTYG TILLHÅLLS
- FERRAMENTAS NECESSÁRIAS

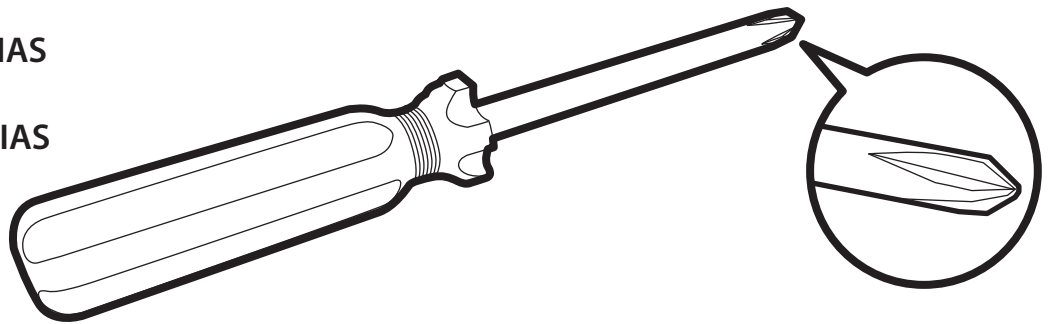

a x42*



b x16*



c x20*



e x3*

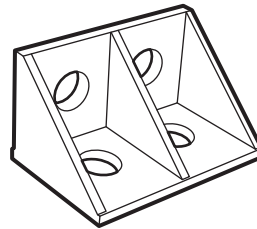

f x5



g x20



h x4

- HARDWARE • HARDWARE • HARDWARE • LAITTEISTO
- MATÉRIEL • HARDWARE • VARNAÐUR • HARDWARE
- HARDWARE • HARDWARE • HARDWARE • HARDWARE

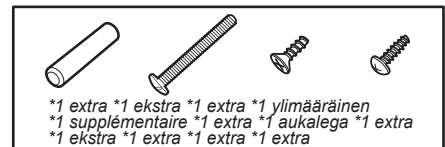

- CORDS • CORDS • KOORDEN • NÖYT • CORDONS • CORDS
- BREYTINGAR • CORDS • KORD • CORDONES • KORD • CORDAS

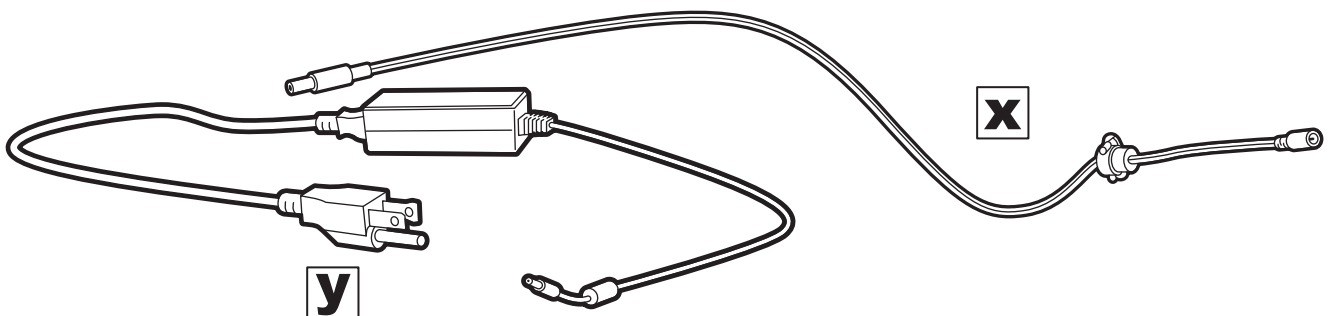

• PARTS • DELER • ONDERDELEN • OSAT • LES PIÈCES • TEILE
 • HLUTAR • PARTI • DELER • PARTES • DELAR • PEÇAS

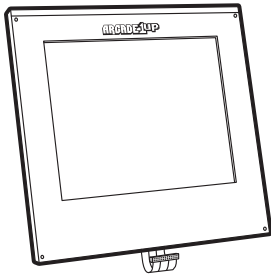

A

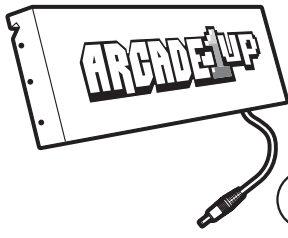

B

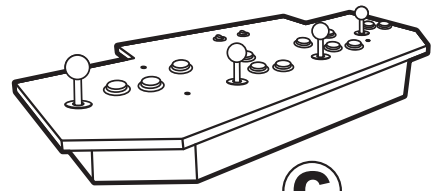

C

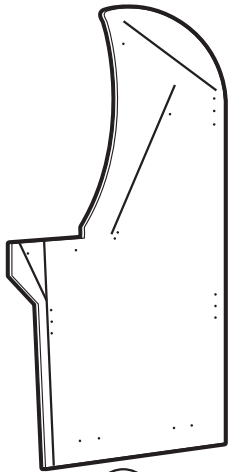

D

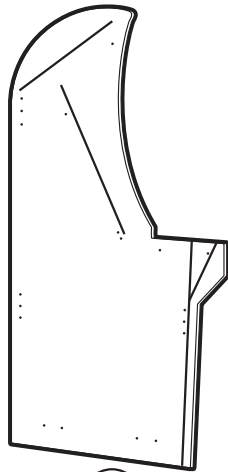

E

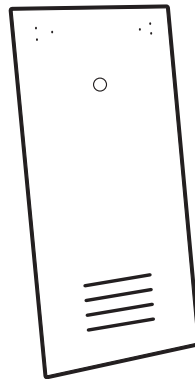

F

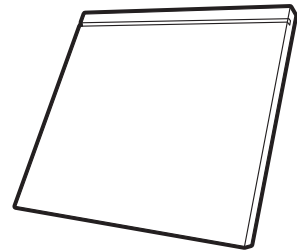

G

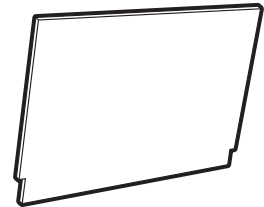

H

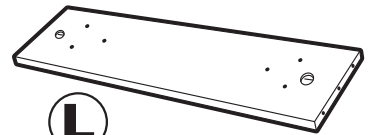

L



I



J

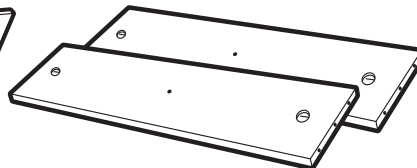

K

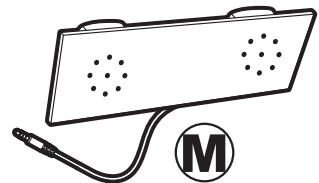

M

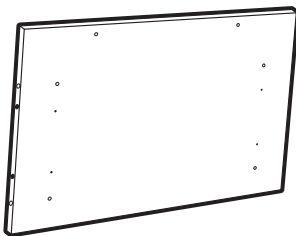

rL

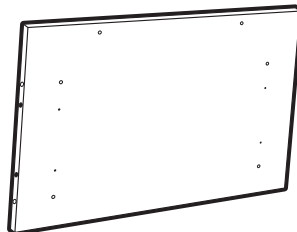

rR

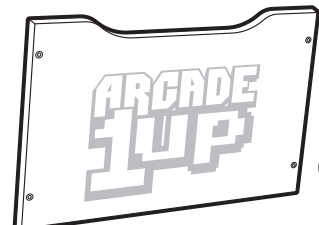

rM

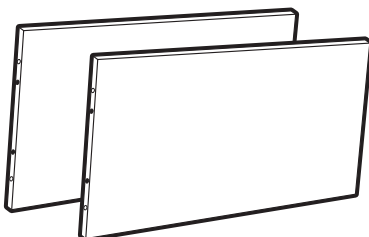

rP

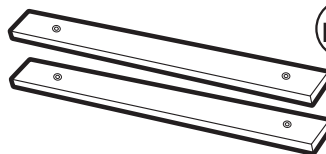

rQ



rO

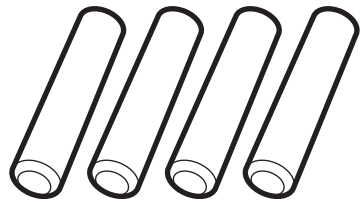

a x 4

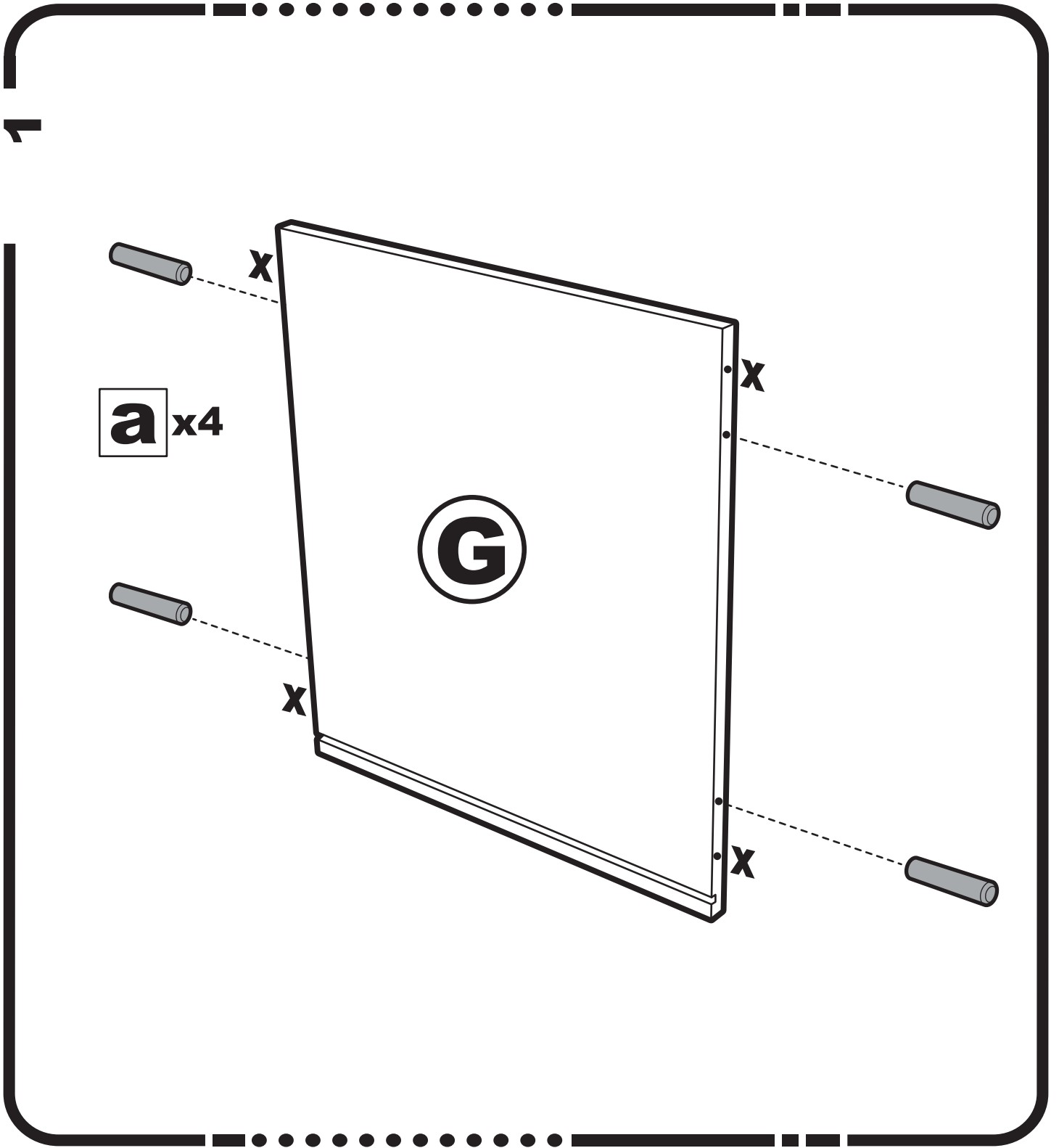

4

2

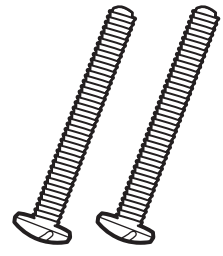

b X 2

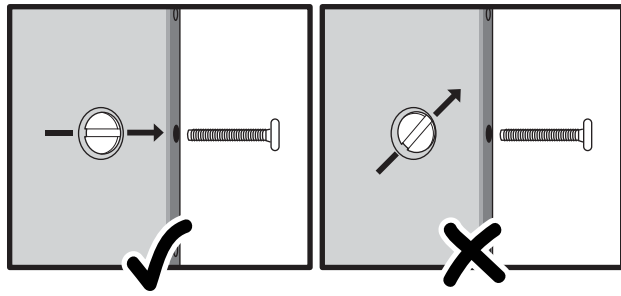
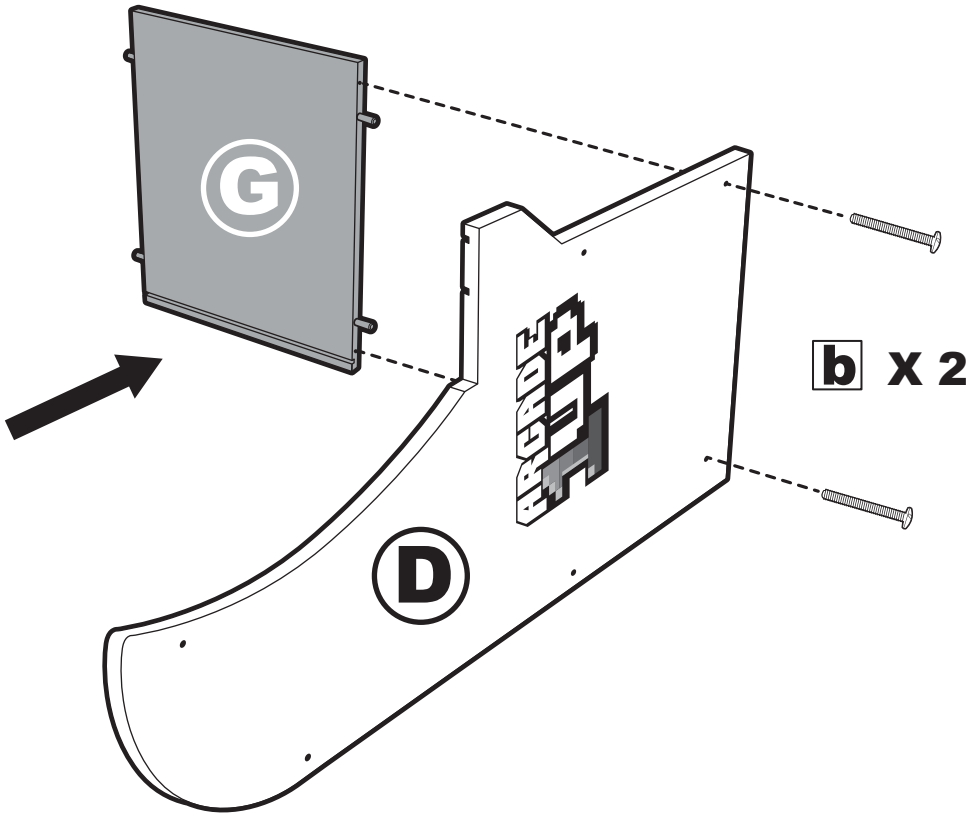

5

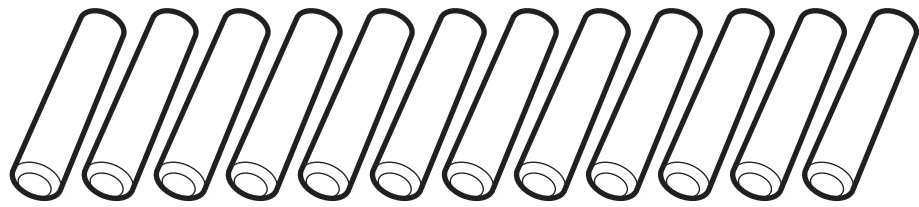

a X 12

3

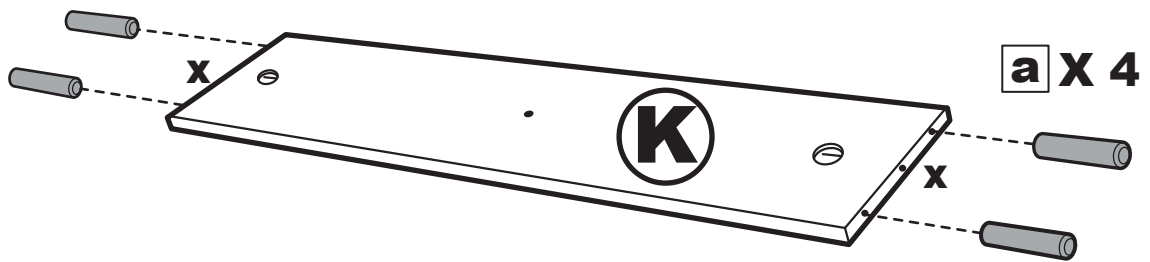

a X 4

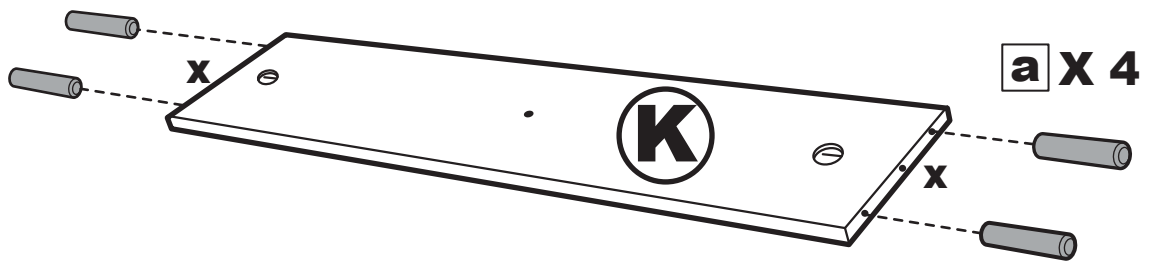

a X 4

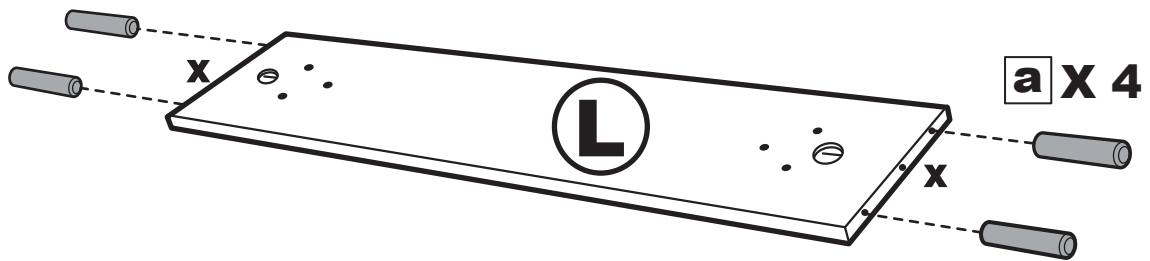

a X 4

6

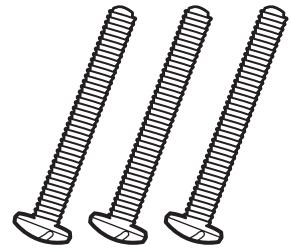

b X 3

4

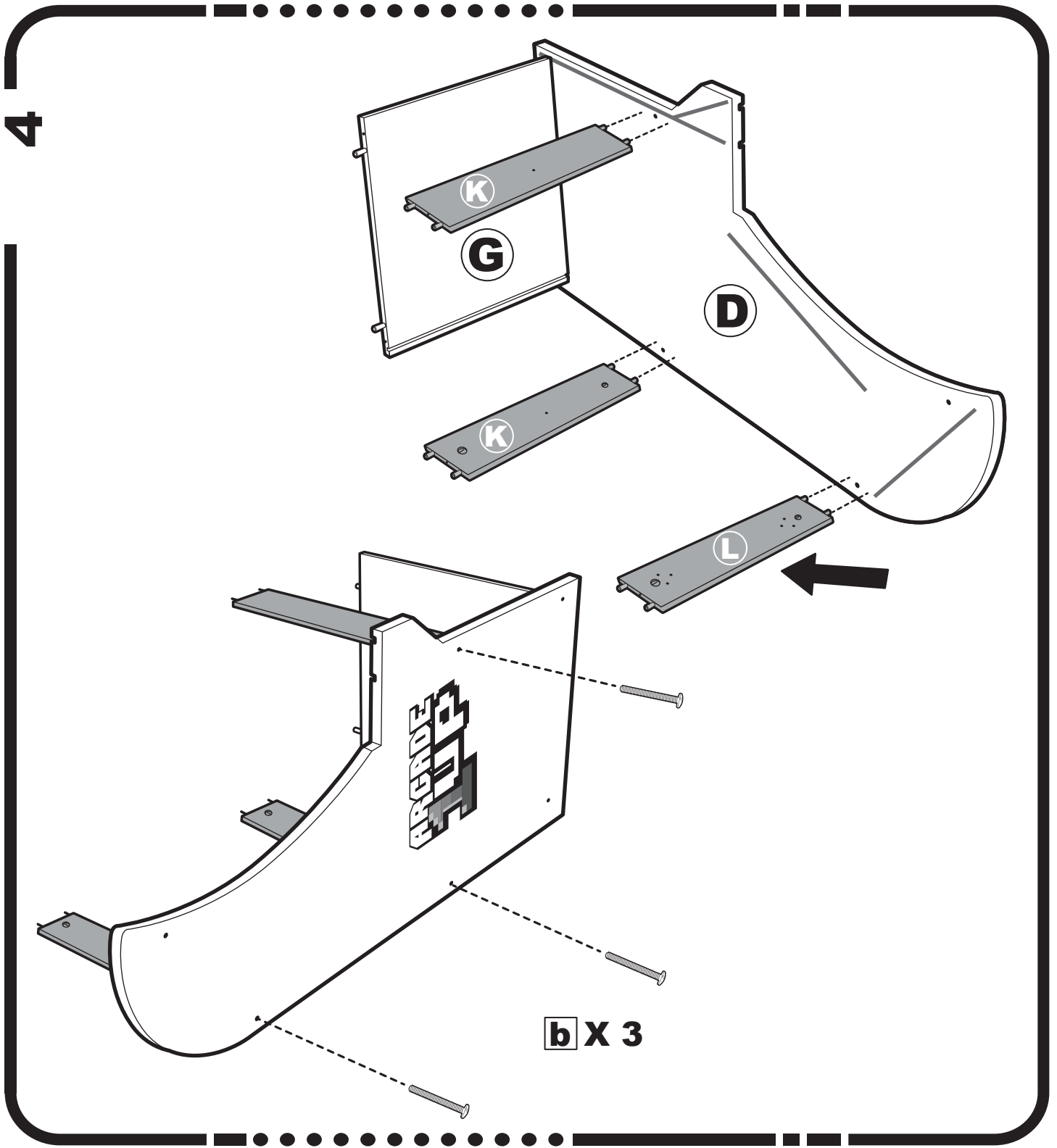

b X 3

7

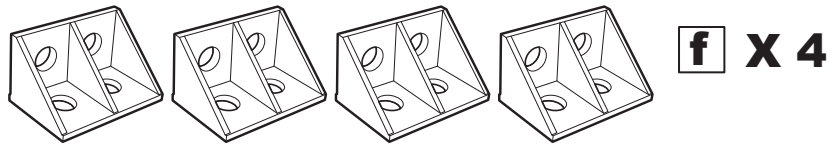

f X 4



c X 8

5

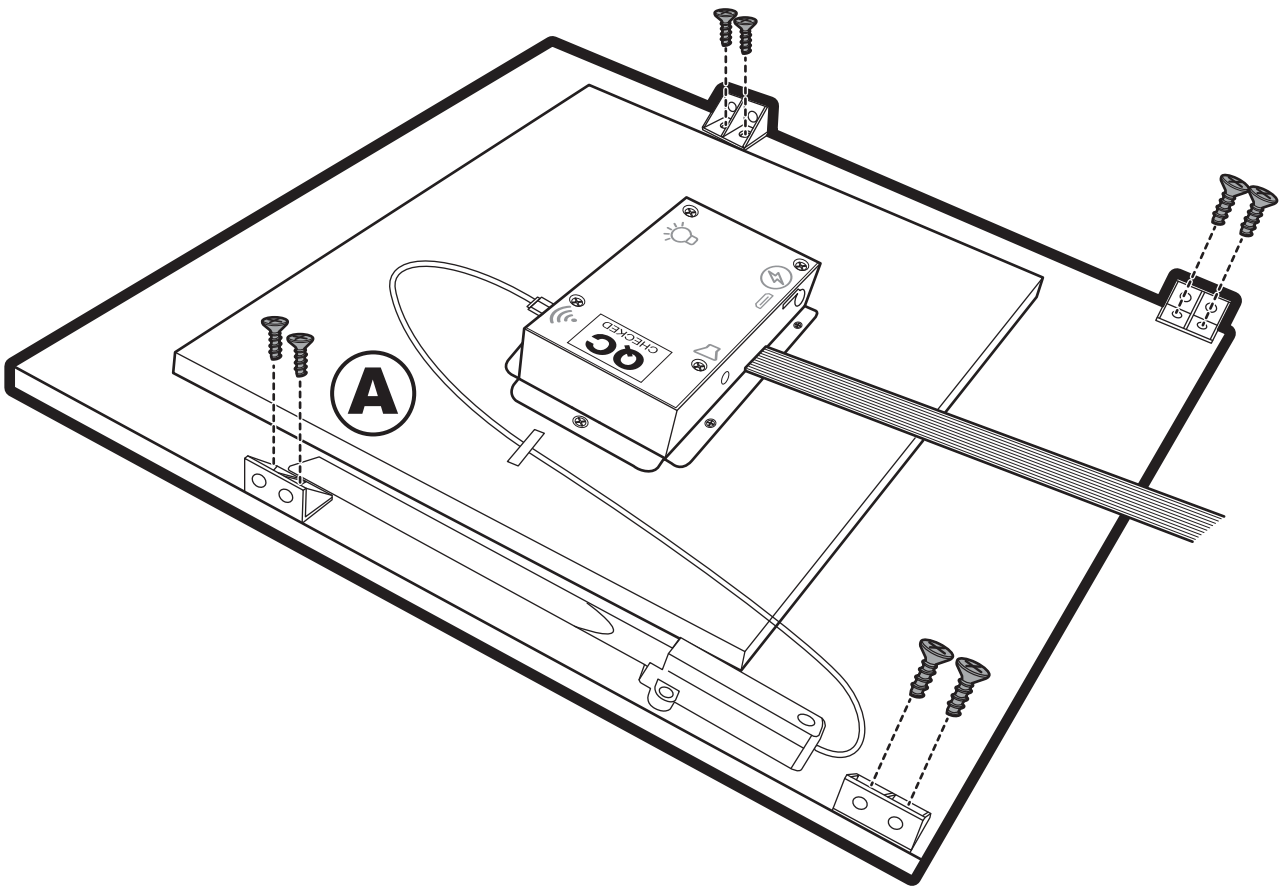

8



c X 4

6

**CAUTION! / ADVARSEL! / LET OP! / VAROITUS! /
MISE EN GARDE! / VORSICHT! / VARÚÐ! / ATTENZIONE! /
FORSIKTIG! / ¡PRECAUCIÓN! / VARNING! / CUIDADO!**

- * PLEASE LAY PANEL D ON A CLEAN SMOOTH SURFACE TO PROTECT FROM SCRATCHES AND DENTS.
- * LÆG VENLIGST PANEL D PÅ EN REN, SMOOTH OVERFLADE TIL AT BESKYTTE MOD SKRAMMER OG BULER.
- * GELIEVE PANEEL D OP EEN SCHOON VLAK OPPERVLAK TE BESCHERMEN TEGEN KRASSEN EN DEUKEN.
- * VAIHDA PANEELI D PUHDASTA, SALLISTA PINNASTA SUOJAAKSESI NAARMUILTA JA HAMPAILTA.
- * VEUILLEZ POSER LE PANNEAU D SUR UNE SURFACE LISSE ET PROPRE POUR VOUS PROTÉGER DES ÉGRATIGNURES ET DES DENTS.
- * BITTE LAGE PANEL D AUF EINE SAUBERE GLATTE OBERFLÄCHE, UM VOR KRATZERN UND DENTS ZU SCHÜTZEN.
- * VINSAMLEGAST LÁÐU PANEL D Á HREINU SMOOTH YFIRBORDI TIL AÐ VERJA GEGN KLÓRA OG BEYGLUM.
- * SI PREGA DI POSIZIONARE IL PANNELLO D SU UNA SUPERFICIE PULITA E LISCIA PER PROTEGGERE DA GRAFFI E AMMACCATURE.
- * LEGG GJERNE PANEL D PÅ EN REN, SMOOTH OVERFLATE FOR Å BESKYTTE FRA SKRATER OG DENTER.
- * POR FAVOR COLOQUE EL PANEL D SOBRE UNA SUPERFICIE LIMPIA Y SUAVE PARA PROTEGER DE RASGUÑONES Y DENTOS.
- * LÄG PÅ PANEL D PÅ EN REN SMOOTH YTTFÖR ATT SKYDDA FRÅN SKRIFTER OCH DENTER.
- * FAVOR COLOCAR O PAINEL D EM UMA SUPERFÍCIE LISA LIMPA PARA PROTEGER DE RISCOS E DENTES.

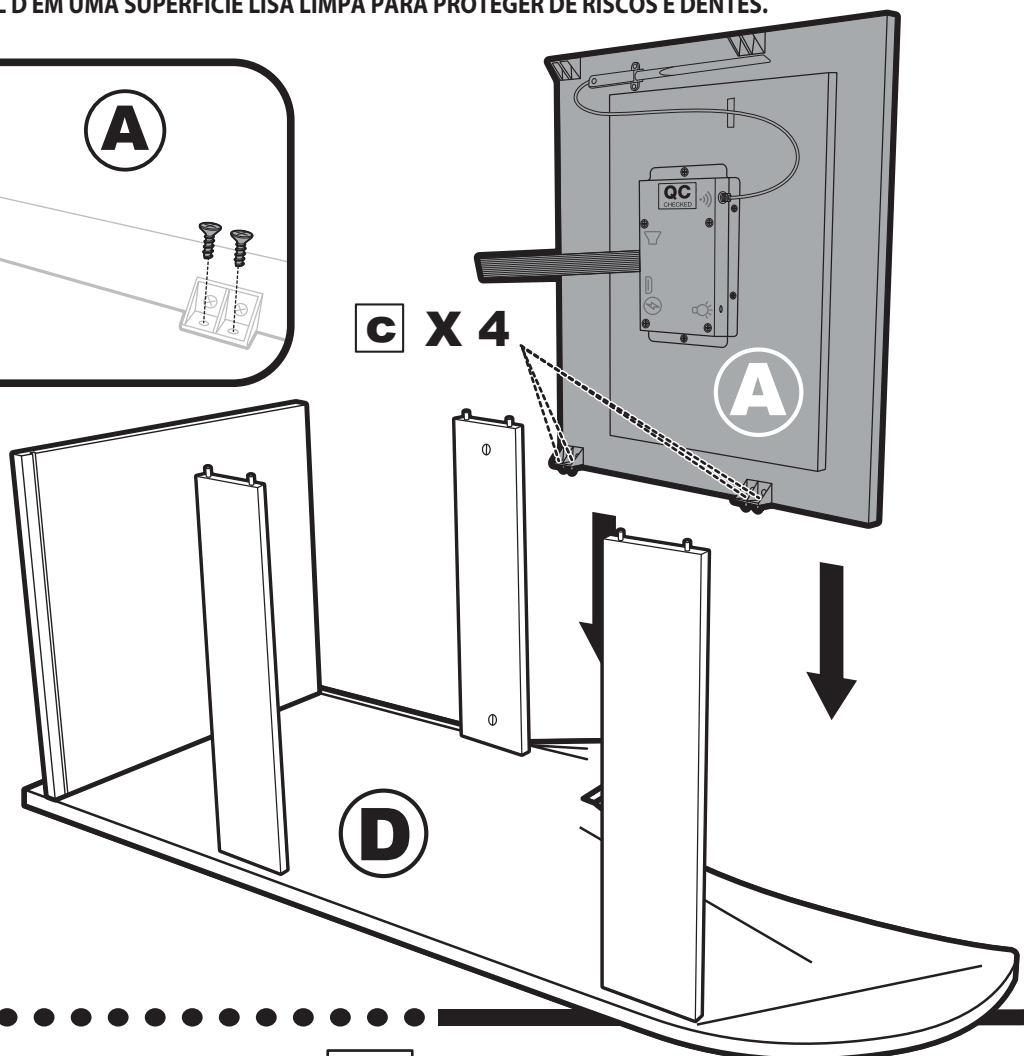
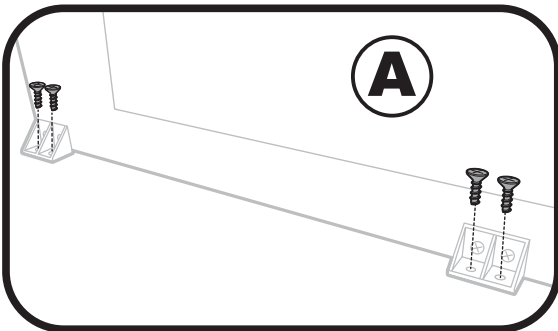

9

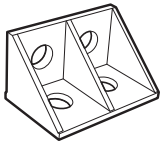

f X 1



c X 2

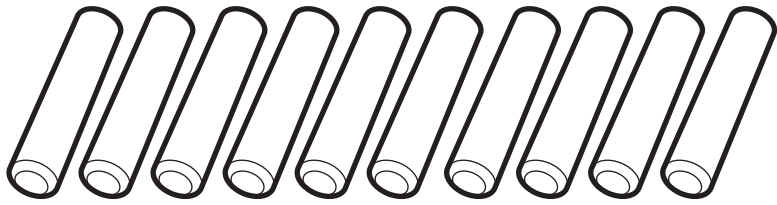

a X 10

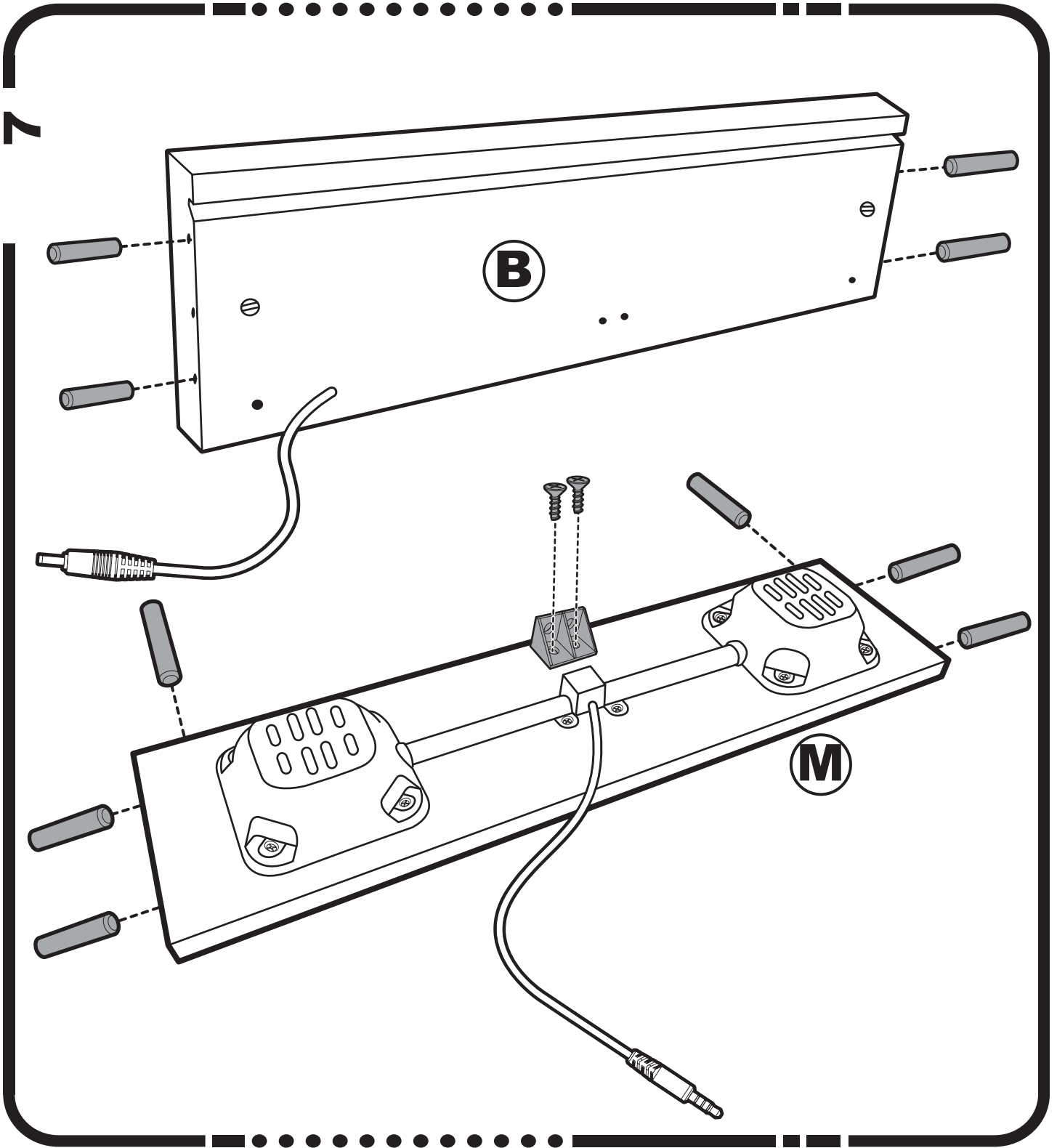



c X 2

8

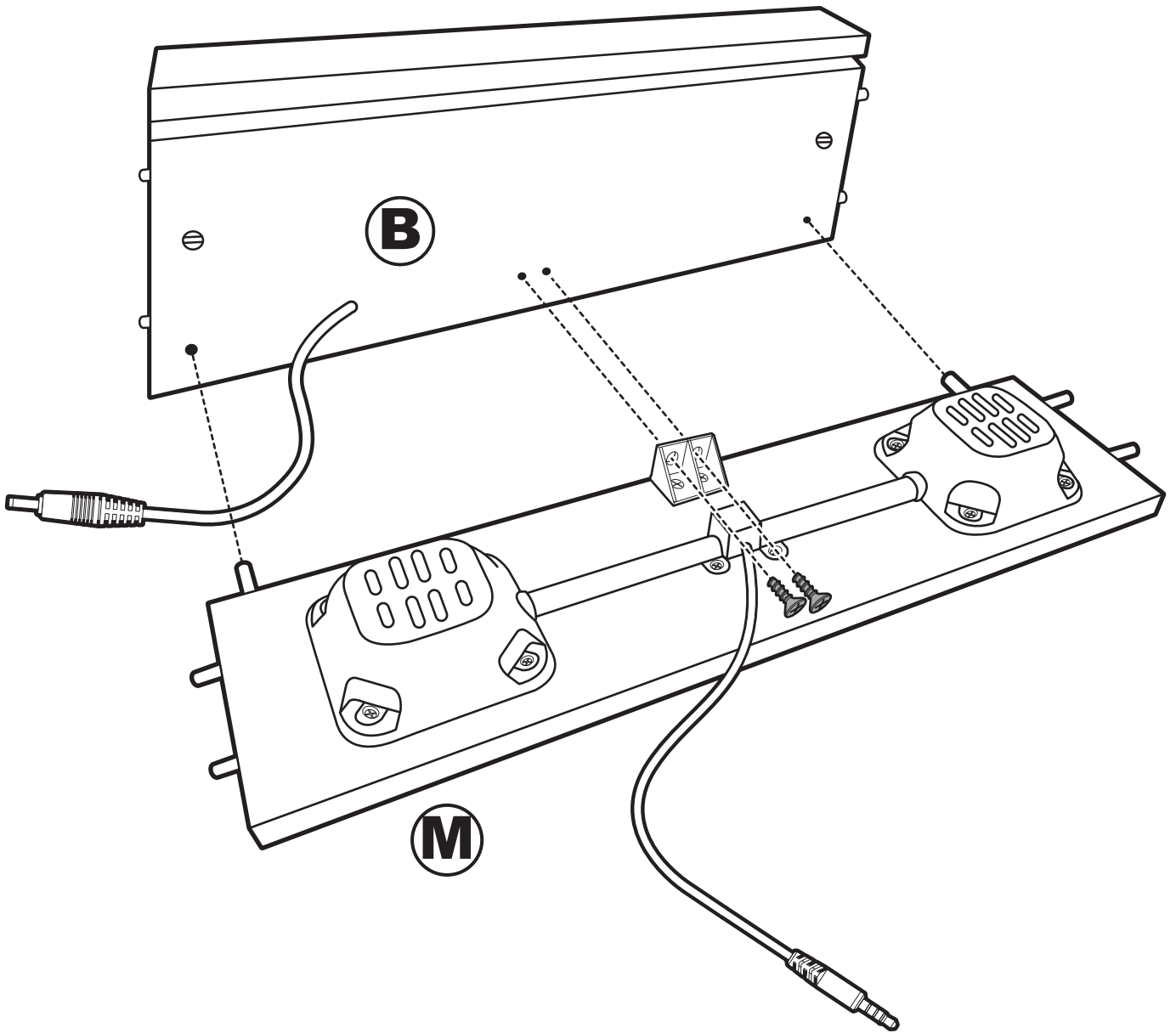

11

9

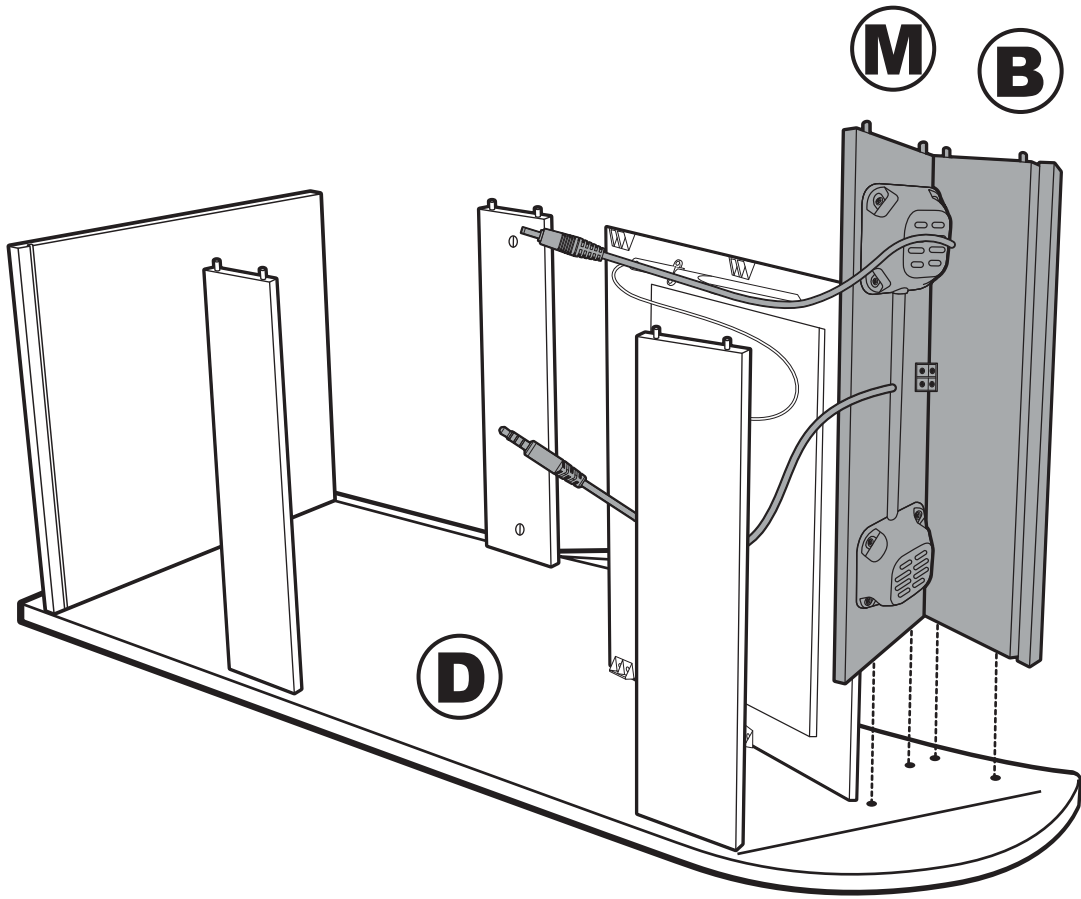

10

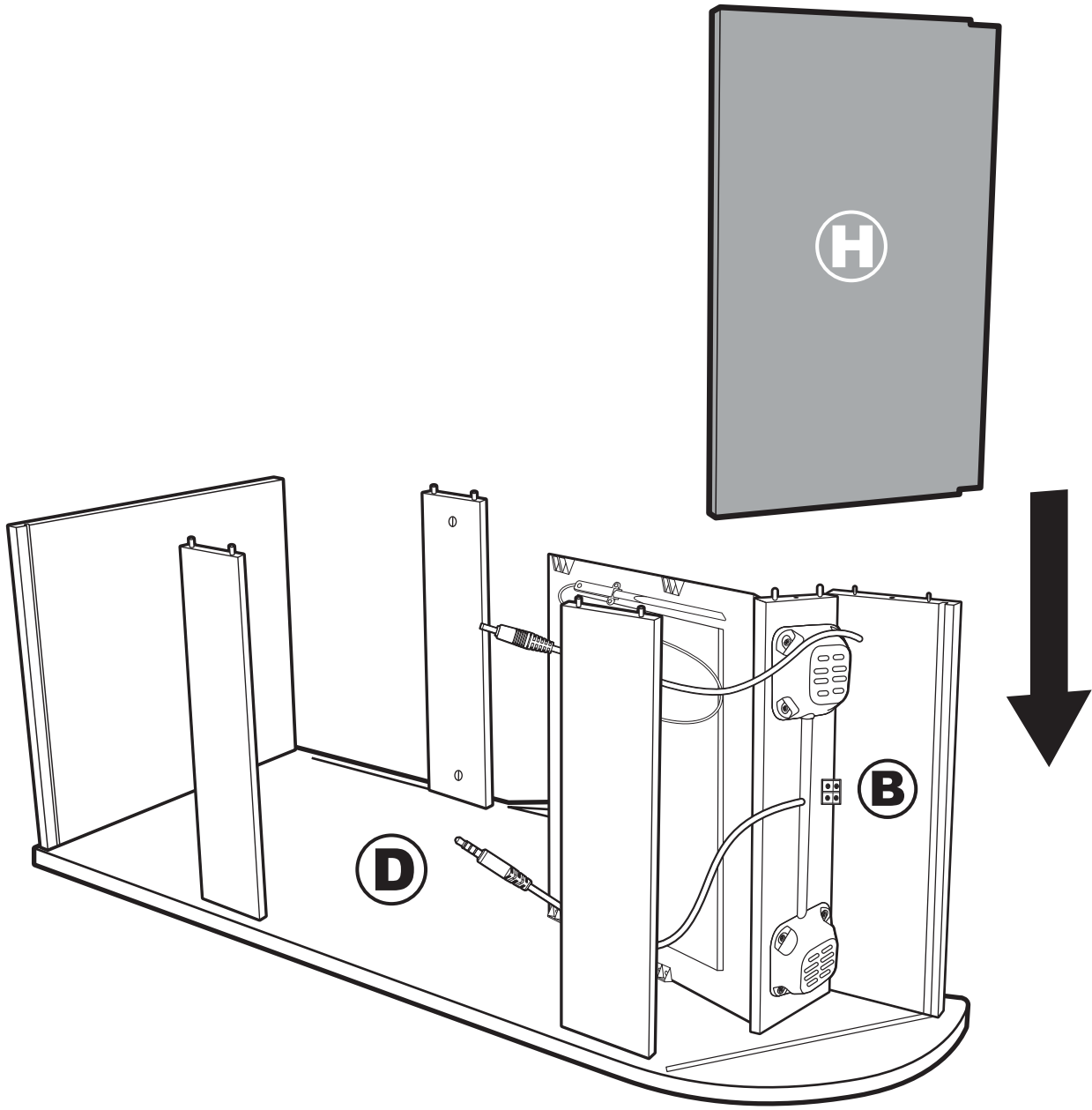

13

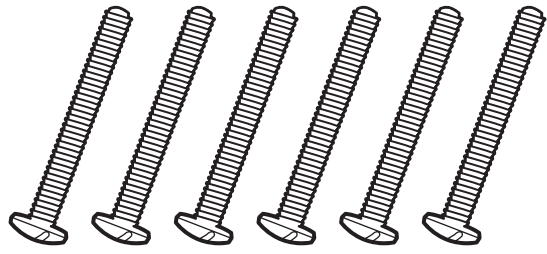

b X 6

11

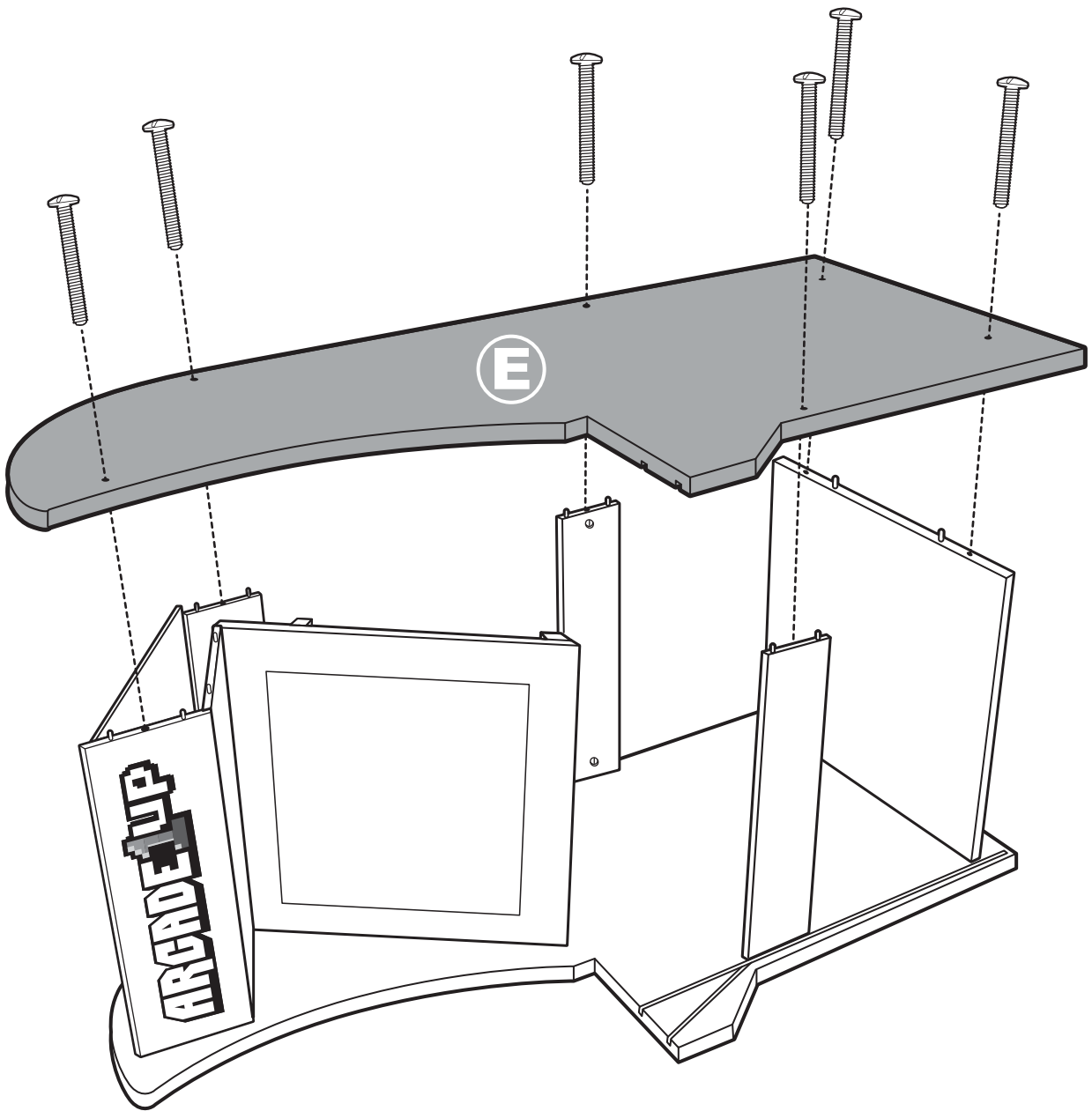

14



C X 4

12

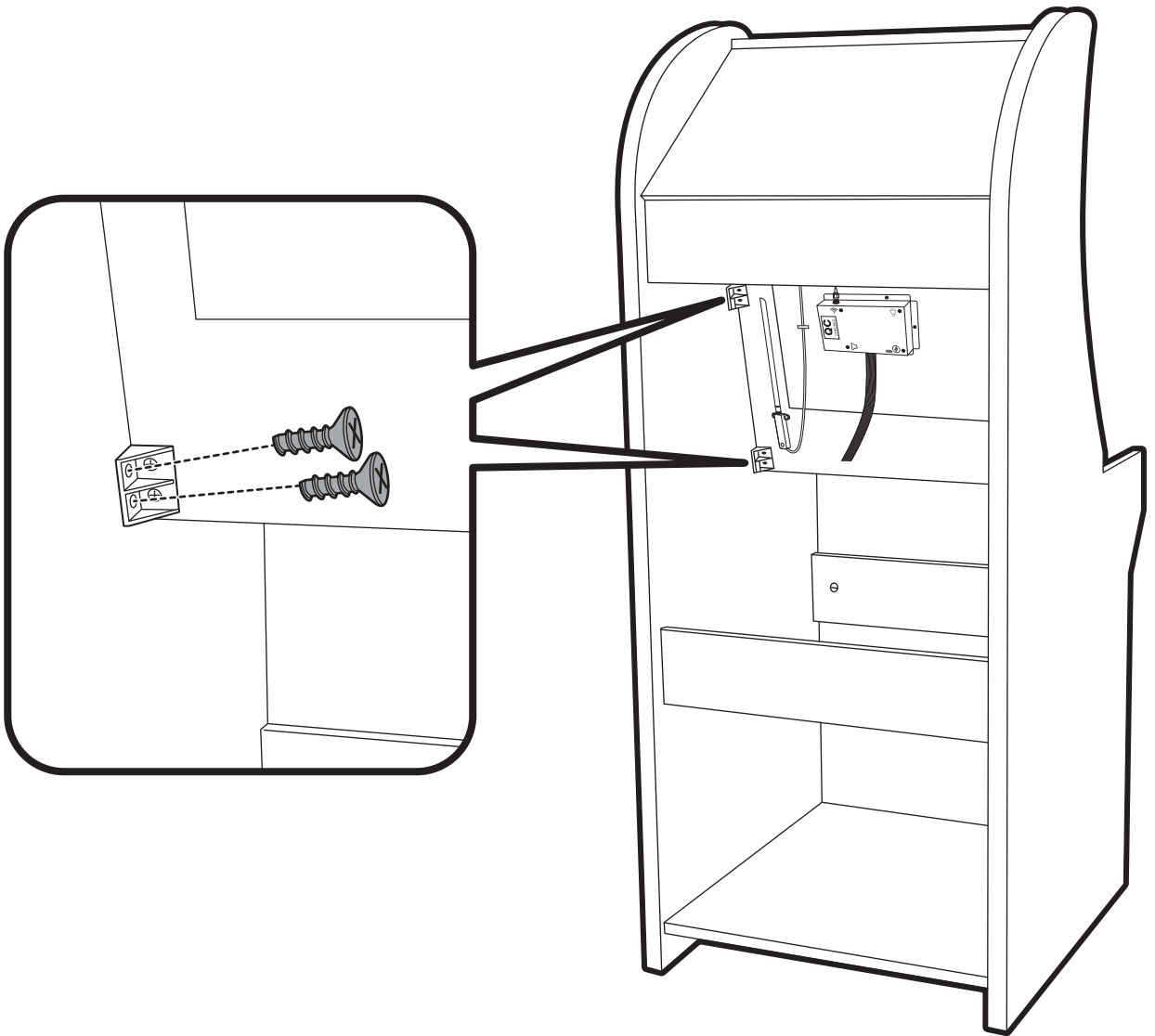

15

13



b X 1

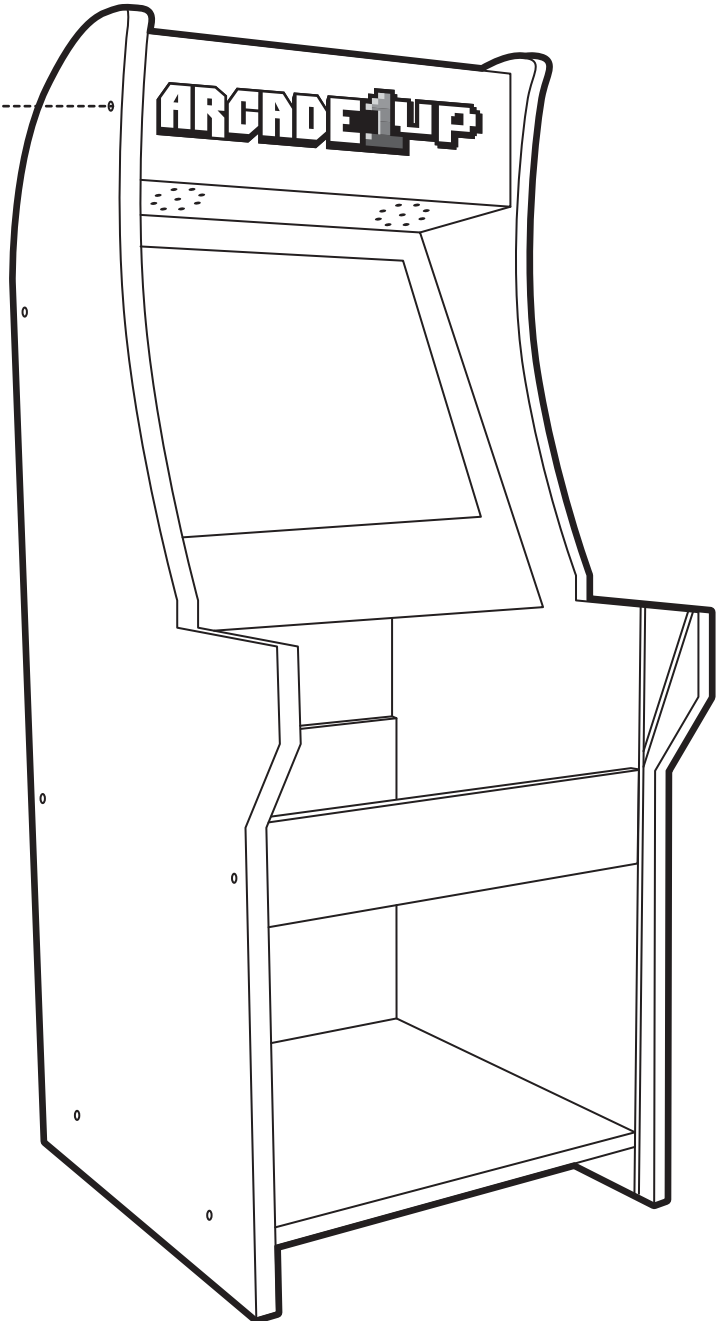

16

14

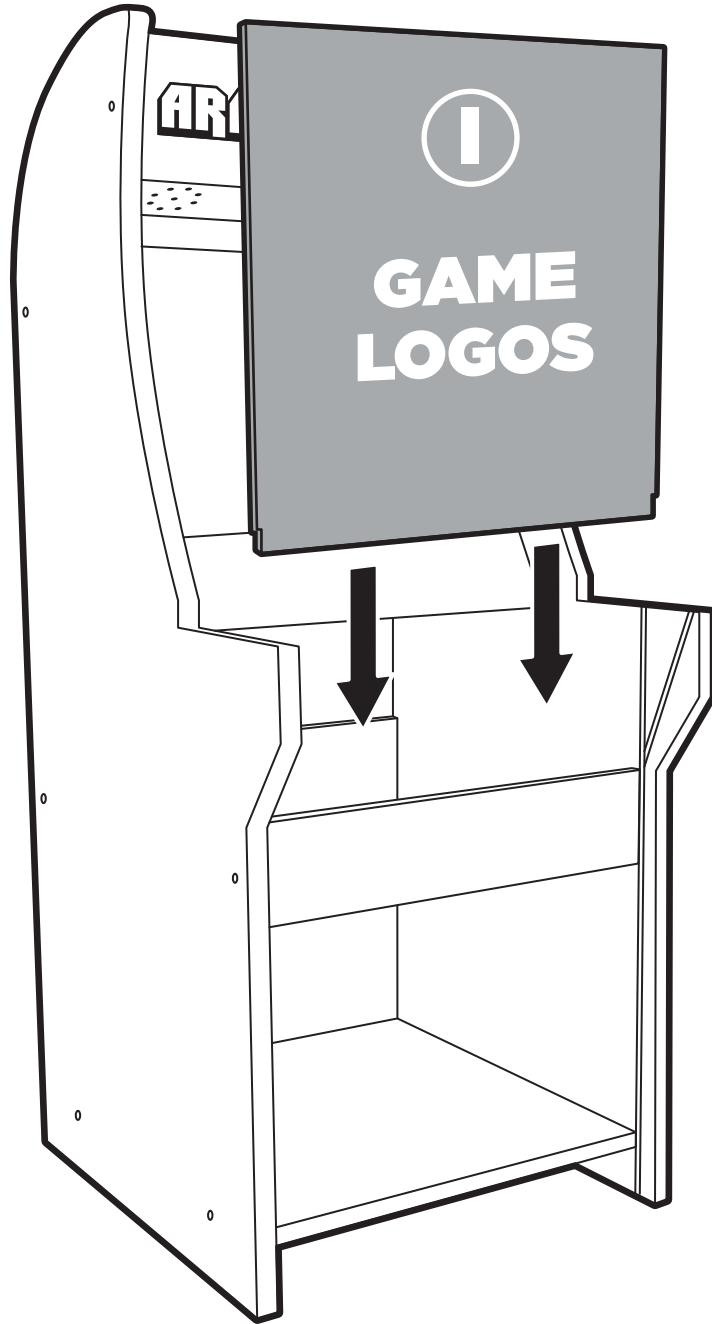

17

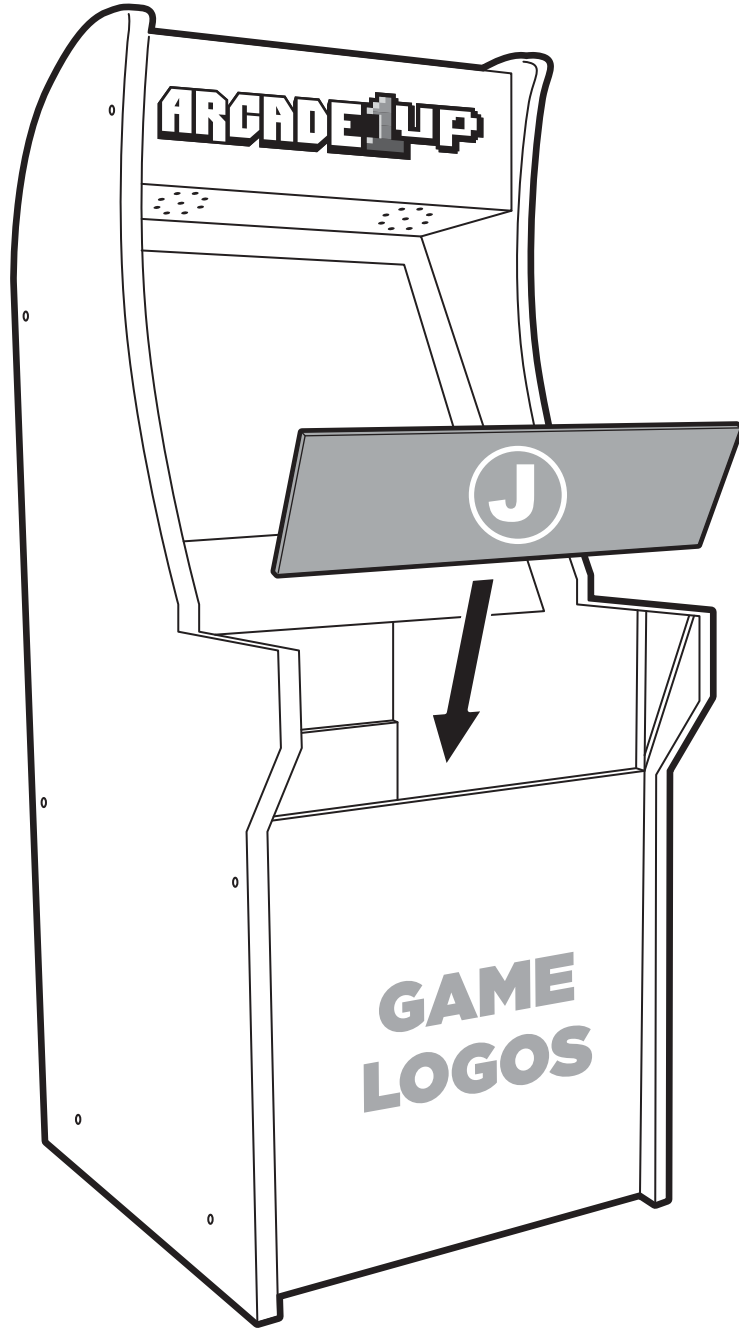



- REMOVE SCREEN PROTECTIVE FILM BEFORE CONTROL DECK ASSEMBLY
- FJERN SKÆRMBESKYTTELSFILMEN INDEN MONTERING AF DÆK
- VERWIJDER DE SCHERMBESCHERMINGSFILM VOORDAT U HET DECK CONTROLEERT
- POISTA NÄYTÖNSUOJAKALVO ENNEN OHJAUSKANNEN KOKOAMISTA
- ENLEVER LE FILM DE PROTECTION ÉCRAN AVANT L'ASSEMBLAGE DU PONTE DE COMMANDE
- ENTFERNEN SIE DEN SCHUTZFILM VOR DER MONTAGE DES STEUERGERÄTS
- FJARLÆGÐU SKERM VERNDANDI KVIKMYND ÁÐUR EN STJÓRNUN ÞILJA ER SETT SAMAN
- RIMUOVERE IL FILM DI PROTEZIONE DELLO SCHERMO PRIMA DEL MONTAGGIO DEL PONTE DI CONTROLLO
- FJERN SKJERMBESKYTTENDE FILM FØR KONTROLLER DECK MONTERING
- RETIRE LA PELÍCULA PROTECTORA DE PANTALLA ANTES DEL MONTAJE DE LA CUBIERTA DE CONTROL
- BORTTAGNING AV SKÄRMSKYDDSFILM FÖRE MONTERING AV DÄCK
- REMOVA O FILME DE PROTEÇÃO DA TELA ANTES DA MONTAGEM DO CONVÉS DE CONTROLE

17

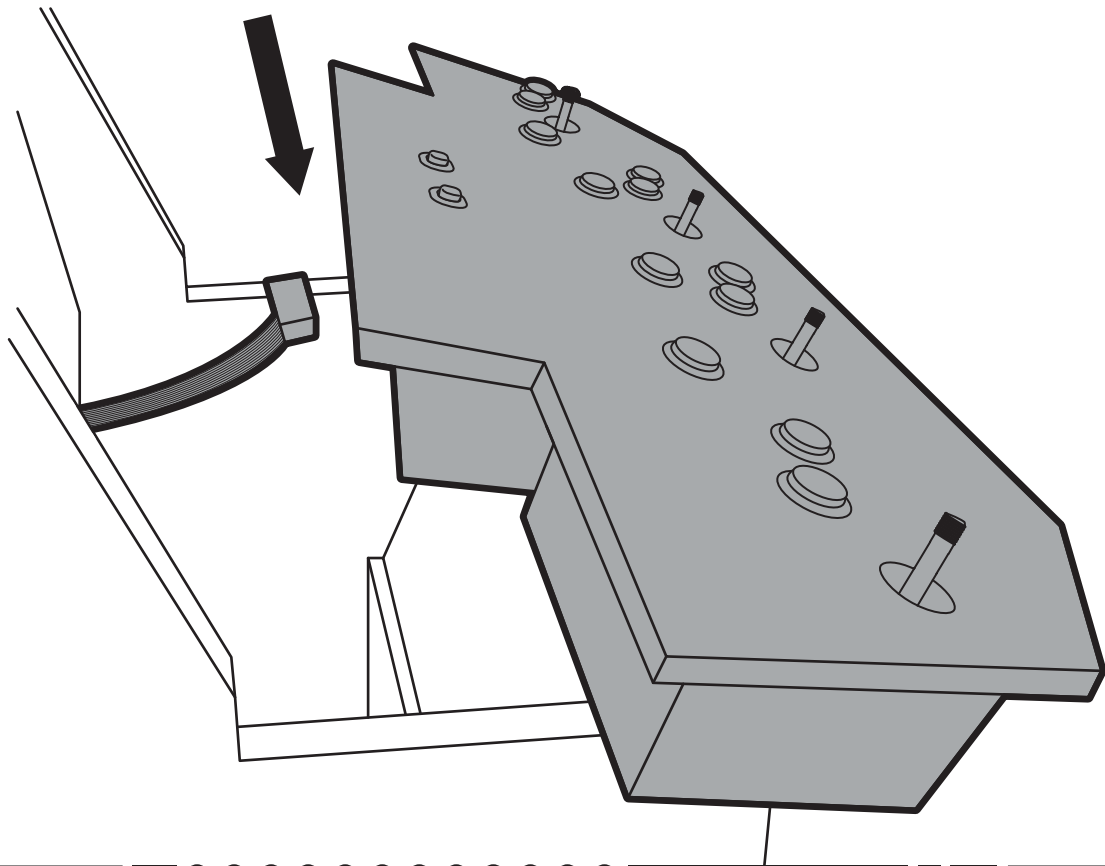

- * REMOVE PROTECTIVE FILMS ON BOTH SIDES OF DECK PROTECTOR BEFORE INSTALLATION
- * FJERN BESKYTTESEFILM PÅ BEGGE SIDER AF DÆKKEBESKYTTELSE INDEN INSTALLATION
- * VERWIJDER BESCHERMINGSFILMS AAN BEIDE ZIJDEN VAN DEKBESCHERMING VOOR INSTALLATIE
- * IRROTAVAT SUOJAKUVAT KANNASUOJAJEN MOLEMMILTA PUOLILTA ENNEN ASENTAMISTA
- * ENLEVER LES FILMS DE PROTECTION DES DEUX CÔTÉS DU PROTECTEUR DE PONT AVANT L'INSTALLATION
- * ENTFERNEN SIE DIE SCHUTZFILME BEIDEN SEITEN DES DECK-SCHUTZES VOR DER INSTALLATION
- * FJARLÆGÐU VERNDANDI KVIKMYNDIR Á BÁÐUM HLIÐUM HLÍÐARHLÍFARSINS FYRIR UPPSETNINGU
- * RIMUOVERE I FILM DI PROTEZIONE SU ENTRAMBI I LATI DEL PROTEZIONE DEL PONTE PRIMA DELL'INSTALLAZIONE
- * FJERNE BESKYTTENDE FILMER PÅ BEGGE SIDER AV DEKKBESKYTTEREN FØR INSTALLASJONEN
- * RETIRE LAS PELÍCULAS DE PROTECCIÓN EN AMBOS LADOS DEL PROTECTOR DE CUBIERTA ANTES DE LA INSTALACIÓN
- * TA BORT SKYDDSFILMER PÅ BÅDA SIDORNA AV DÄCKSKYDD FÖRE INSTALLATIONEN
- * REMOVA OS FILMES DE PROTEÇÃO EM AMBOS OS LADOS DO PROTETOR DE DECK ANTES DA INSTALAÇÃO

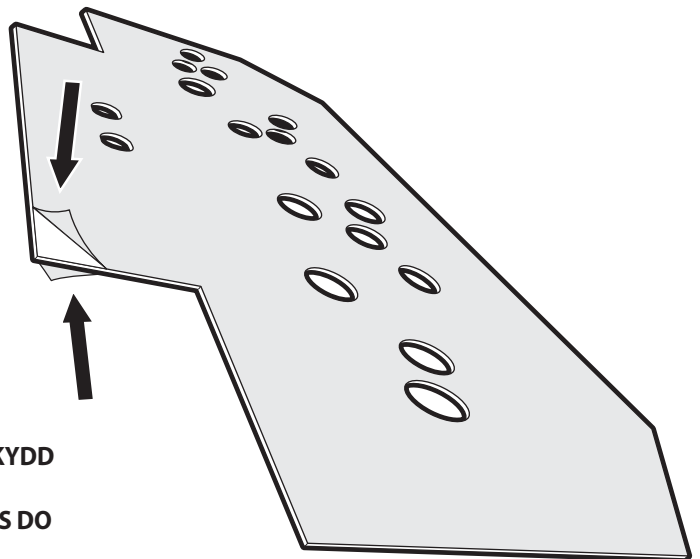

20

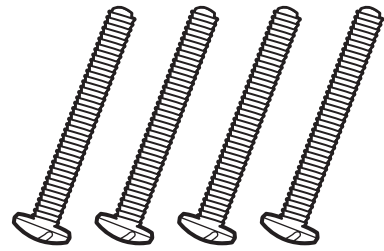

b X 4

**CAUTION! / ADVARSEL! / LET OP! / VAROITUS! /
MISE EN GARDE! / VORSICHT! / VARÚÐ! / ATTENZIONE! /
FORSIKTIG! / ¡PRECAUCIÓN! / VARNING! / CUIDADO!**

HAND TIGHTEN ONLY / KUN HÅNDTREJNING / ALLEEN MET DE HAND AANGEDRAAID / KÄSITTELY VAIN VAIN /
SERRER À LA MAIN UNIQUEMENT / NUR HANDZIEHEN / AÐEINS HAND HERTU / STRINGERE SOLO /
KUN HÅNDTRYKK / APRETAR A MANO SOLAMENTE / HANDTÄTTNING ENDAST / APORTE APENAS A MÃO /

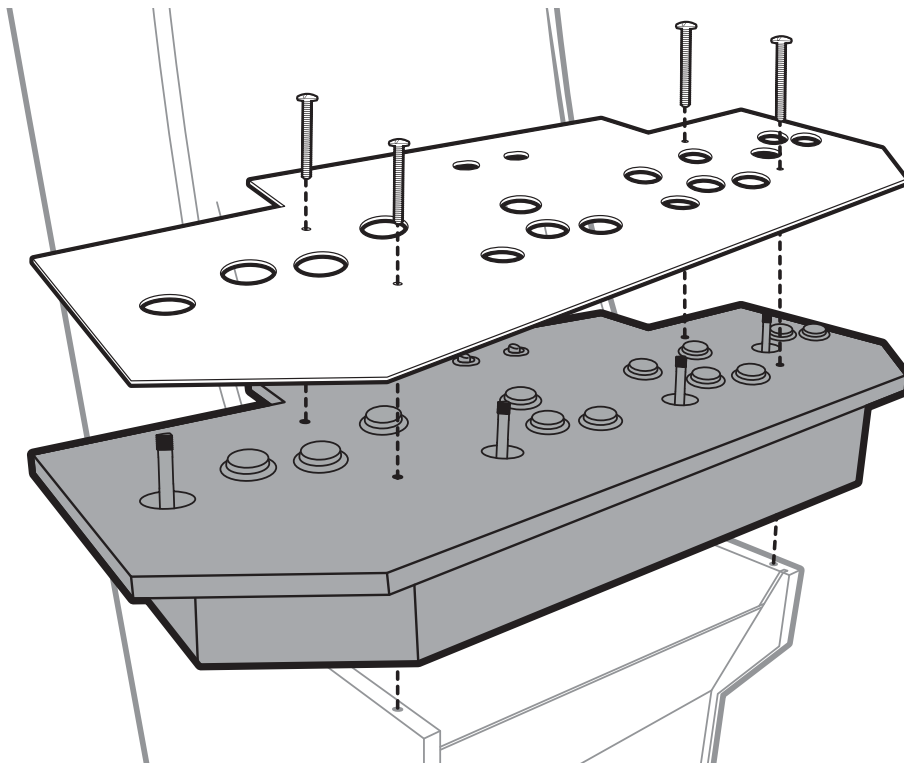

*** INSTALL JOYSTICK FOLLOW DIRECTIONS**

- INSTALLER JOYSTICK FOLLOW DIRECTIONS
- INSTALLEER JOYSTICK VOLG DE ROUTEBESCHRIJVING
- ASENTA JOYSTICK FOLLOW DIRECTIONS
- INSTALLER LE JOYSTICK SUIVRE LES INSTRUCTIONS
- INSTALLIEREN SIE JOYSTICK-FOLGUNGSANWEISUNGEN
- SETJIÐ JOYSTICK FOLLOW TILBENDINGAR
- INSTALLARE JOYSTICK SEGUIRE LE DIREZIONI
- INSTALLER JOYSTICK FOLLOW DIRECTIONS
- INSTALAR JOYSTICK SEGUIR DIRECCIONES
- INSTALLERA JOYSTICK FOLLOW DIRECTIONS
- INSTALAR O JOYSTICK SEGUIR AS DIREÇÕES

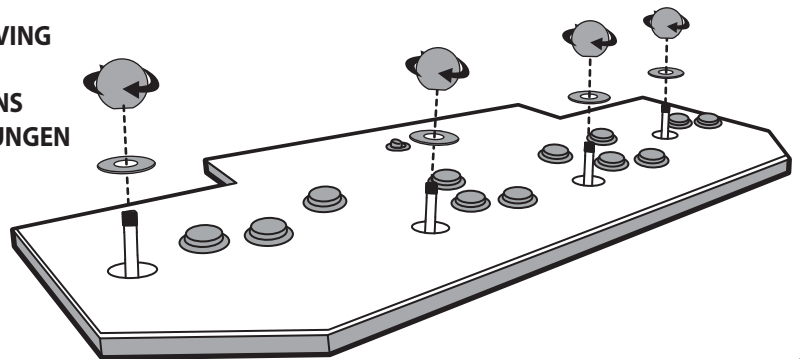

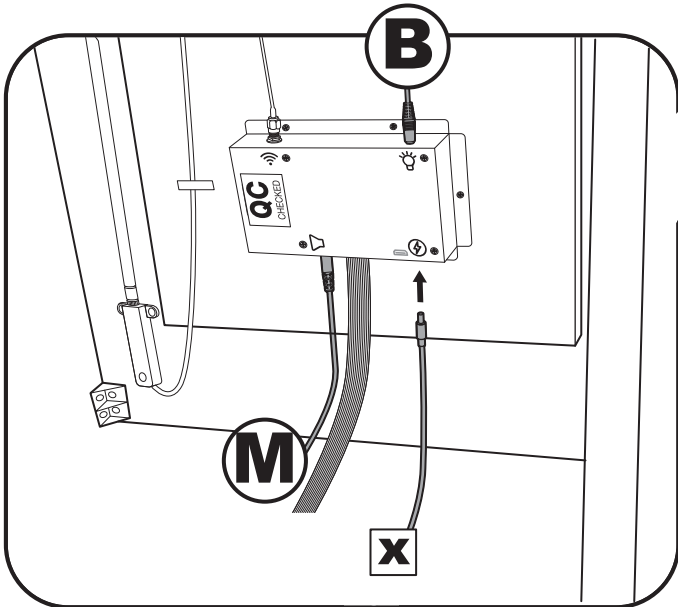
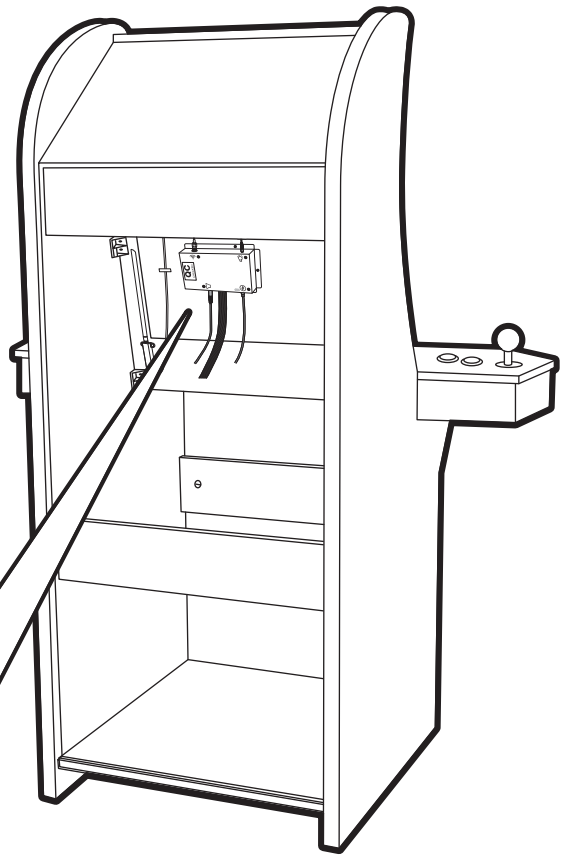
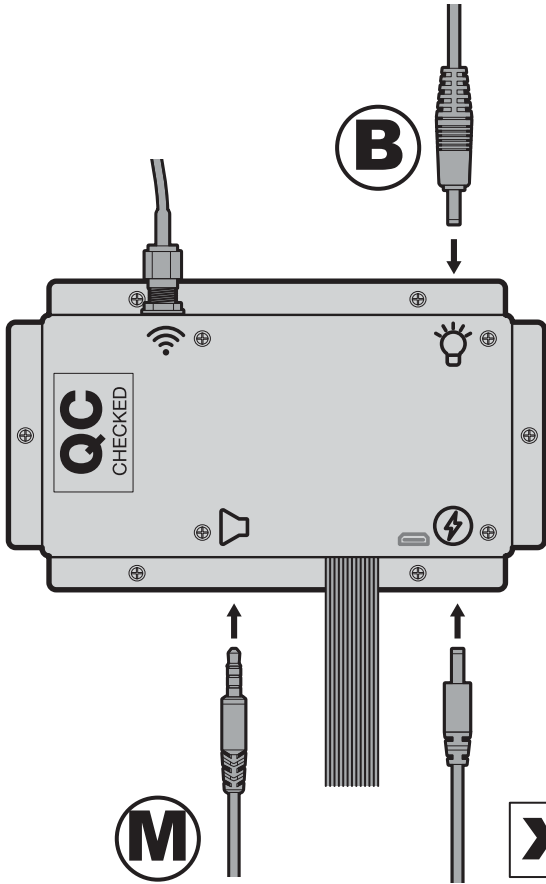
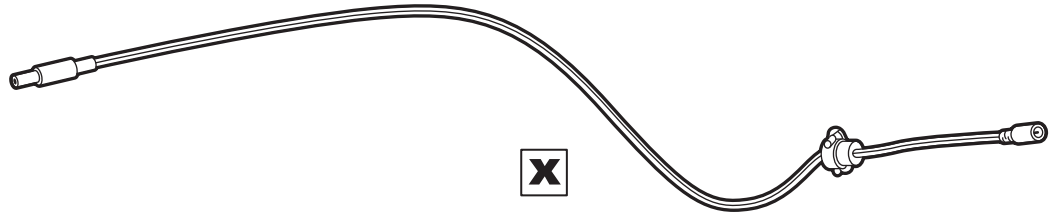

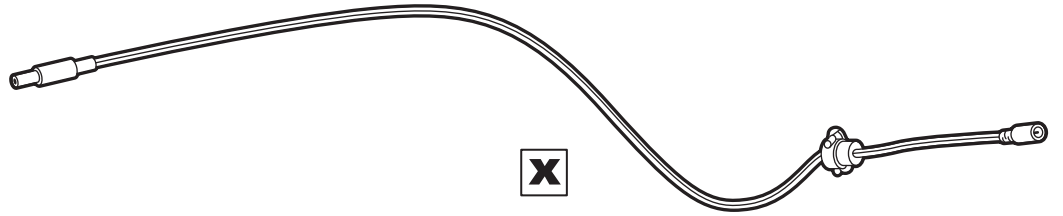

20

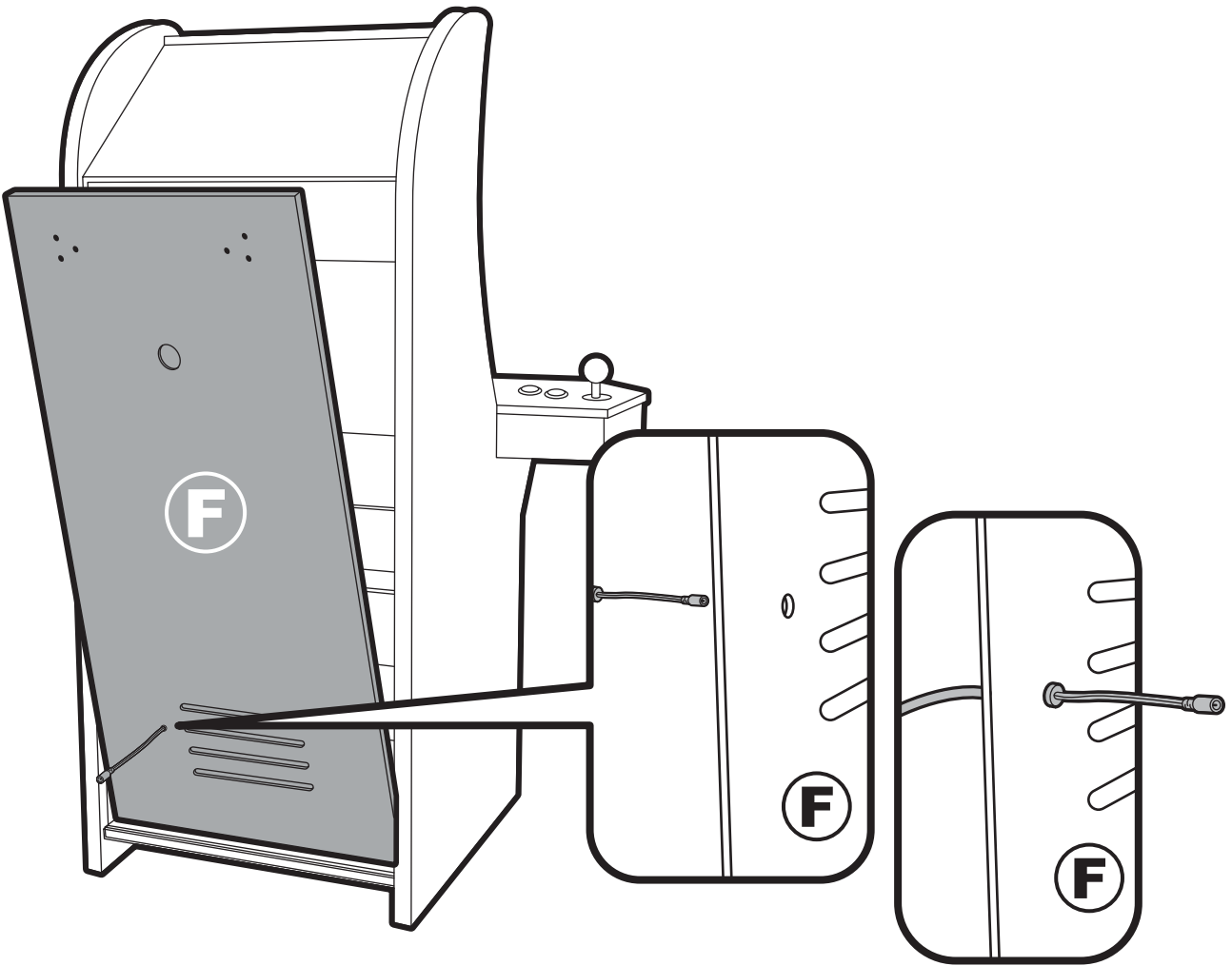

23

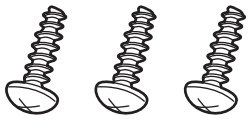

e X 3

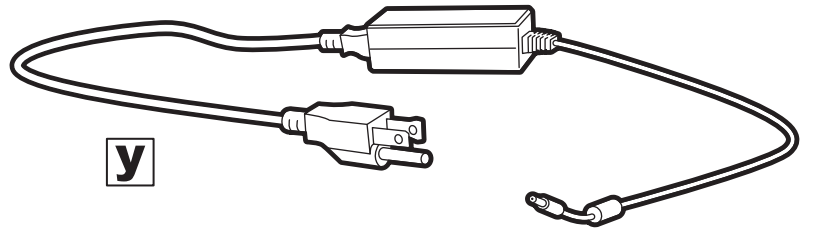

y

21

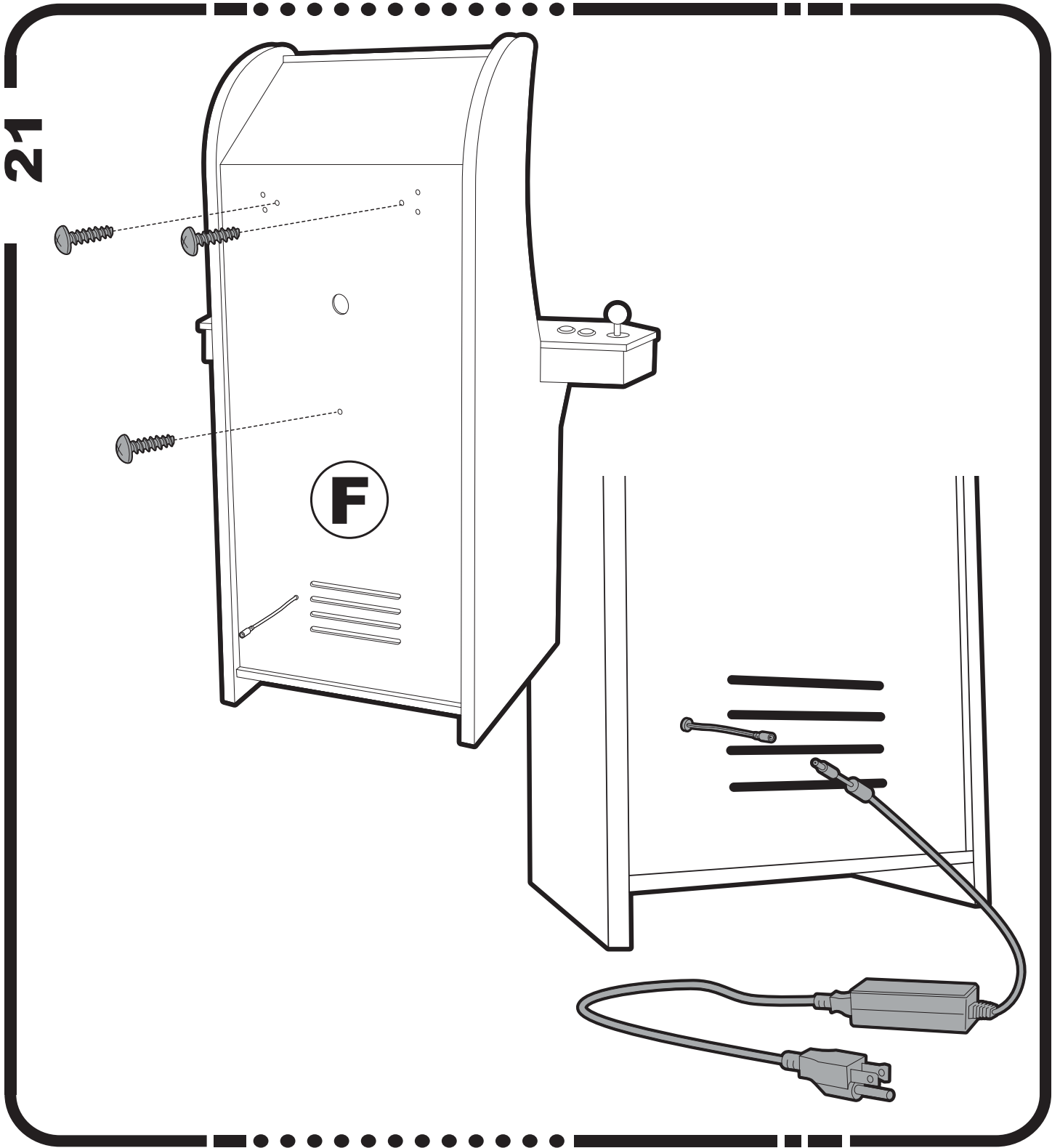

24

⚠ WARNING



Children have died from furniture products tipping over. To reduce the risk of unit tip over:

- ALWAYS install Anti Tip Over device provided.
- NEVER allow children to stand, climb or hang on game.
- Set up on level floor.

WARNING: Arcade1UP assumes no liability for improper installation or excessive loads placed on screws or bracket. This wall anchor is not a substitute for proper adult supervision.

⚠ WAARSCHUWING



Kinderen zijn gestorven aan het kantelen van meubels. Om het risico op omvallen van de unit te verminderen:

- Installeer ALTIJD het meegeleverde Anti Tip Over-apparaat.
- Laat kinderen NOOIT staan, klimmen of aan het spel hangen.
- Opgezet op een vlakke vloer.

WAARSCHUWING: Arcade1UP is niet aansprakelijk voor ondeskundige montage of overmatige belasting van schroeven of steunen. Dit muuranker is geen vervanging voor goed toezicht door volwassenen.

⚠ ATTENTION



Des enfants sont morts de renversement de produits d'ameublement. Pour réduire le risque de renversement de l'unité:

- TOUJOURS installer le dispositif anti-basculement fourni.
- NE JAMAIS laisser les enfants se tenir debout, grimper ou s'accrocher au gibier.
- Installation sur sol plat.

ATTENTION: Arcade1UP décline toute responsabilité en cas de mauvaise installation ou de surcharge sur les vis ou les équerres. Ce système d'ancrage ne remplace pas la surveillance d'un adulte.

⚠ AÐVÖRUN



Börn hafa látist af völdum húsgagnaafurða. Til að draga úr hættu á því að hlutum sé hallað yfir:

- Setjið ALLTAF upp Anti Tip Over tæki sem fylgir.
- Láttu ALDREI börn standa, klifra eða hanga á leik.
- Settu upp á hæð hæð.

AÐVÖRUN: Arcade1UP tekur enga 0225byrgð á rangri uppsetningu eða of miklum þunga sem er lagður á skrúurnar eða rammann. Þessi veggfesting kemur ekki í staðinn fyrir rétt eftirlit foreldra.

⚠ ADVARSEL



Barn har dædd av at møbelprodukter velter. For å redusere risikoen for at enheten velter:

- Installer ALLTID Anti Tip Over-enheten som følger med.
- La ALDRI barn stå, klatre eller henge på lek.
- Sett opp i plan etasje.

ADVARSEL: Arcade1UP påtar seg intet ansvar for feil installasjon eller for store belastninger på skruer eller brakett. Denne veggforankringen er ikke en erstatning for riktig tilsyn av en voksen.

⚠ WARNING



Barn har dött av möbelprodukter som tippat över. För att minska risken för att enheten välter:

- Installera ALLTID Anti Tip Over-enhet som tillhandahålls.
- Låt ALDRIG barn stå, klättra eller hänga på spelet.
- Ställ in på plan våning.

WARNING: Arcade1UP påtar sig inget ansvar för felaktig installation eller för stor belastning på skruvar eller fästn/brickor. Denna väggförankring är inte ett substitut för tillbörlig vuxenuppsikt.

⚠ ADVARSEL



Børn er døde af møbelprodukter, der vælter. Sådan reduceres risikoen for enhedens vippe:

- Installer ALLTID Anti Tip Over udstyr leveret.
- Lad ALDRIG børn stå, klatre eller hænge på leg.
- Indstil på plant niveau.

ADVARSEL: Arcade1UP påtager sig intet ansvar for forkert installation eller for store belastninger placeret på skruer eller beslag. Dette væganker er ikke en erstatning for korrekt voksenovervågning.

⚠ VAROITUS



Lapset ovat kuolleet huonekalujen kaatumisen vuoksi. Yksikön kaatumisriskin vähentämiseksi:

- AINA asenna mukana toimitettu Anti Tip Over -laite.
- ÄLÄ KOSKAAN anna lasten seisoa, kiivetä tai ripustaa peiliin.
- Aseta tasaiselle lattialle.

VAROITUS: Arcade1UP ei ota minkäänlaista vastuuta epäasianmukaisesta asennuksesta tai liiallisesta ruuveille tai kannattimille kohdistetusta kuormasta. Tämä sinäankkuri ei korvaa asianmukaista aikuisen valvontaa.

⚠ ACHTUNG



Kinder sind an umgekippten Möbelprodukten gestorben. So verringern Sie das Risiko eines Umkippens des Geräts:

- Installieren Sie IMMER das mitgelieferte Anti-Tip-Over-Gerät.
- Lassen Sie Kinder NIEMALS stehen, klettern oder am Spiel hängen.
- Auf ebenem Boden aufstellen.

ACHTUNG: Arcade1UP übernimmt keine Haftung für unsachgemäße Montage oder übermäßige Belastungen an Schrauben und Halterungen. Der Wandanker ist kein Ersatz für die ordnungsgemäße Beaufsichtigung durch Erwachsene.

⚠ AVVERTENZA



I bambini sono morti a causa del ribaltamento dei prodotti di arredamento. Per ridurre il rischio di ribaltamento dell'unità:

- SEMPRE installare il dispositivo Anti Tip Over fornito.
- Non permettere MAI ai bambini di stare in piedi, arrampicarsi o restare in gioco.
- Installazione al piano terra.

AVVERTENZA: Arcade1UP non si assume alcuna responsabilità per un'installazione impropria o per carichi eccessivi sulle viti o sulla staffa. Questo ancoraggio a parete non sostituisce un'adeguata supervisione da parte di un adulto.

⚠ ADVERTENCIA



Los niños han muerto por la caída de productos de muebles. Para reducir el riesgo de vuelco de la unidad:

- SIEMPRE instale el dispositivo Anti Tip Over provisto.
- NUNCA permita que los niños se paren, trepen o cuelguen del juego.
- Instalar en piso nivelado.

ADVERTENCIA: Arcade1UP no acepta responsabilidades por instalación incorrecta o por cargas excesivas colocadas en tornillos o ensoportes. Este anclaje de pared no sustituye a una supervisión adulta adecuada.

⚠ AVISO



Crianças morreram devido à queda de produtos de móveis. Para reduzir o risco de tombamento da unidade:

- SEMPRE instale o dispositivo Anti Tip Over fornecido.
- NUNCA permita que as crianças fiquem em pé, subam ou se pendurem no jogo.
- Instale no piso plano.

AVISO: O Arcade1UP não assume nenhuma responsabilidade por instalação inadequada ou cargas excessivas colocadas nos parafusos ou no suporte. Esta âncora de parede não é um substituto para a supervisão adequada de um adulto.



a X 16

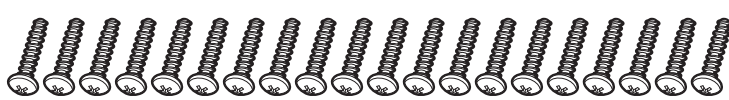

g X 20



h X 4

22

1

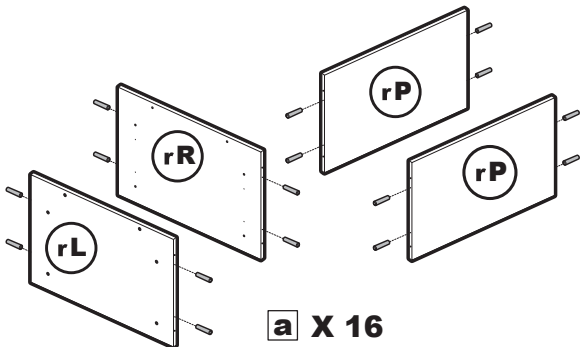

a X 16

2

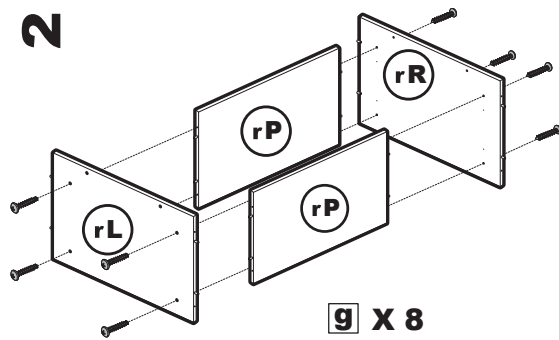

g X 8

3

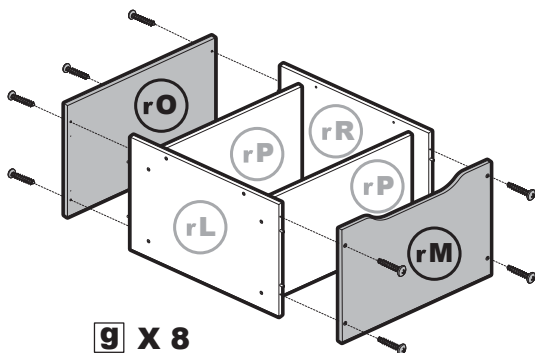

g X 8

4

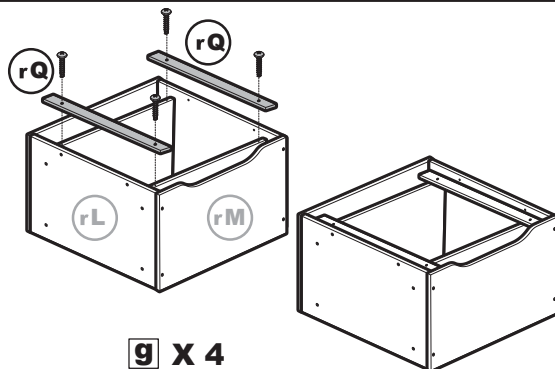

g X 4

5

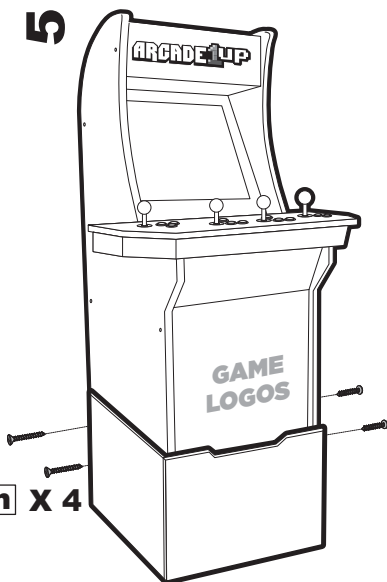

h X 4

- There are no pre-drilled holes on the Arcade side panels, use self-tapping screws **h** to fix the riser and arcade to prevented serious injury or death.
- Der er ingen forborede huller på Arcade-sidepanelerne. Brug selvskærende skruer **h** til at fastgøre stigerøret og arkaden for at forhindre alvorlig personskada eller død.
- Er zijn geen voorgeboorde gaten in de Arcade-zijpanelen, gebruik zelftappende schroeven **h** om de riser en arcade te bevestigen om ernstig letsel of de dood te voorkomen.
- Pelihallin sivupaneeleissa ei ole ennalta porattuja reikiä. Kiinnitä nokka ja arcade kiinnittämällä itsekierteittäviä ruuveja **h** vakavien vammojen tai kuoleman estämiseksi.
- Il n'y a pas de trous pré-perçés sur les panneaux latéraux de l'Arcade, utilisez des vis autotaraudeuses **h** pour fixer la contremarche et l'arcade pour éviter des blessures graves ou la mort.
- Die Arcade-Seitenwände haben keine vorgebohrten Löcher. Befestigen Sie den Riser und die Arcade mit selbstschneidenden Schrauben **h**, um schwere oder tödliche Verletzungen zu vermeiden.
- Engar förborraðar holur eru á hliðarspöldum Arcade, notaðu sjálfskrúfandi skrúfur **h** til að festa stígvélina og spílakassann til að koma í veg fyrir alvarleg meiðsl eða dauða.
- Non ci sono fori preforati sui pannelli laterali Arcade, utilizzare viti autofilettanti **h** per fissare il montante e il porticato per prevenire lesioni gravi o morte.
- Det er ingen forhåndsborede hull på arkadens sidepaneler, bruk selvskruende skruer **h** for å fikske stigerøret og arkaden for å forhindre alvorlig personskada eller død.
- No hay agujeros pretaladrados en los paneles laterales Arcade, utilice tornillos autorroscantes **h** para fijar el elevador y la arcade para evitar lesiones graves o la muerte.
- Det finns inga förborrade hål på arkadens sidopaneler, använd självtappande skruvar **h** för att fixa stigare och arkaden för att förhindra allvarlig personskada eller dödsfall.
- Não há furos pré-perfurados nos painéis laterais do Arcade, use parafusos auto-atarraxantes **h** para fixar o elevador e a arcade para evitar ferimentos graves ou morte.

ADVARSEL: For at forhindre alvorlig personskada eller død, skal skruer bruges til at fastgøre stigerøret til spillet.

WAARSCHUWING: Om ernstig letsel of de dood te voorkomen, moeten schroeven worden gebruikt om de riser aan het spel te bevestigen.

VAROITUS: Vakavan loukkaantumisen tai kuoleman estämiseksi nousuputki on kiinnitettävä ruuveilla.

VAROITUS: Um schwere oder tödliche Verletzungen zu vermeiden, müssen Schrauben verwendet werden, um den Riser am Spiel zu befestigen.

VIDVÖRUN: Til að koma í veg fyrir alvarleg meiðsl eða dauða, verður að nota skrúfur til að tryggja uppstigið á leikim.

ATTENZIONE: Per prevenire lesioni gravi o morte, è necessario utilizzare viti per fissare il riser al gioco.

ADVARSEL: For å forhindre alvorlig personskada eller død, må skruer brukes for å feste stigerøret til spillet.

VARNING: För att förhindra allvarlig personskada eller dödsfall måste skruvar användas för att säkra stigerøret till spillet.

AVISO: Para evitar ferimentos graves ou morte, devem ser utilizados parafusos para prender o riser ao jogo.

WARNING: To prevent serious injury or death, screws must be used to secure the riser to the Arcade.

AVERTISSEMENT: Pour éviter des blessures graves ou la mort, des vis doivent être utilisées pour fixer la colonne montante à l'Arcade.

ADVERTENCIA: Para evitar lesiones graves o la muerte, se deben usar tornillos para asegurar el elevador al Arcade.

WARNING: This apparatus must be securely attached to the wall in accordance with the installation instruction to prevented serious injury or death.

AVERTISSEMENT: Cet appareil doit être solidement fixé au mur conformément aux instructions d'installation pour éviter des blessures graves ou la mort.

ADVERTENCIA: Este aparato debe estar firmemente sujeto a la pared de acuerdo con las instrucciones de instalación para evitar lesiones graves o la muerte.

ADVARSEL: Dette apparat skal være sikkert fastgjort til væggen i overensstemmelse med installationsinstruktionen for at forhindre alvorlig personskade eller død.
WAARSCHUWING: dit apparaat moet stevig aan de muur worden bevestigd in overeenstemming met de installatie-instructies om ernstig letsel of de dood te voorkomen.
VAROITUS: Tämä laite on kiinnitettävä tiukasti seinään asennusohjeiden mukaisesti vakavien vammojen tai kuoleman estämiseksi.
WARNUNG: Dieses Gerät muss gemäß den Installationsanweisungen sicher an der Wand befestigt sein, um schwere oder tödliche Verletzungen zu vermeiden.
VIÐVÖRUN: Þetta tæki verður að vera tryggilega fest við vegginn í samræmi við leiðbeiningar um uppsetningu til að koma í veg fyrir alvarleg meiðsl eða dauða.
ATTENZIONE: Questo apparecchio deve essere fissato saldamente alla parete in conformità con le istruzioni di installazione per prevenire lesioni gravi o morte.
ADVARSEL: Dette apparatet må være forsvarlig festet til veggjen i samsvar med monteringsanvisningen for å forhindre alvorlig personskade eller død.
VARNING: Denna apparat måste vara ordentligt fäst på väggen i enlighet med installationsinstruktionen för att förhindra allvarlig personskada eller dödsfall.
AVISO: Este aparelho deve ser fixado firmemente à parede de acordo com as instruções de instalação para evitar ferimentos graves ou morte.

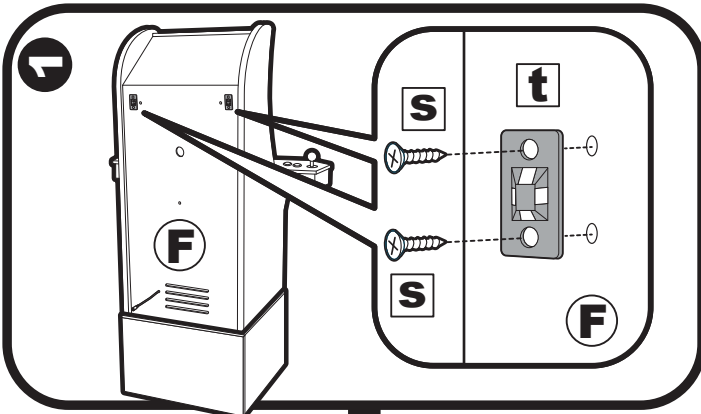

ANTI TIP DEVICE / SIKKERHEDSSTRAP / VEILIGHEIDSRIM / TURVAPEITE /
 SANGLE SÉCURITÉ / SICHEREITSGURT / ÖRYGGI STRAP / CINTURINO DI SICUREZZA /
 SIKKERHETSSTRAP / CORREA DE SEGURIDAD / SÄKERHETSSTRAP / CORREIA DE SEGURANÇA

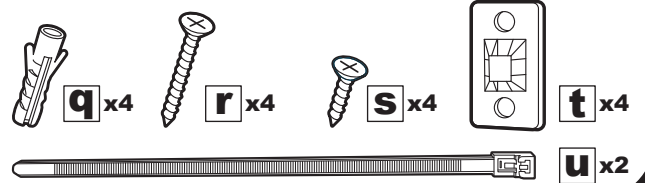

- * Use a stud finder to locate two (or more) studs within the desired area (studs may be 16 inches apart from another).
- * Brug en stud finder til at lokalisere to (eller flere) studs i det ønskede område (studs kan være 16 tommer fra hinanden).
- * Gebruik een stud finder om twee (of meer) studs binnen het gewenste gebied te lokaliseren (studs kunnen 16 inch van elkaar verwijderd zijn).
- * Käytä nastanappulaa löytääksesi kaksi (tai useampaa) nastaa halutulle alueelle (nastat voivat olla 16 tuuman päässä toisistaan).
- * Utilisez un détecteur de montants pour localiser deux (ou plus) montants dans la zone souhaitée (les montants peuvent être à 16 pouces l'un de l'autre).
- * Verwenden Sie einen Bolzensucher, um zwei (oder mehr) Bolzen innerhalb des gewünschten Bereichs zu lokalisieren (Bolzen können 16 Zoll voneinander entfernt sein).
- * Notaðu foli finnara til að finna tvo (eða fleiri) pinnar innan viðkomandi svæðis (pinnar geta verið 16 tommur frá öðrum).
- * Utilizzare un cercatore di tacchetti per individuare due (o più) tacchetti all'interno dell'area desiderata (i tacchetti potrebbero essere distanti 16 pollici l'uno dall'altro).
- * Bruk en stud finder for å finne to (eller flere) pigger i ønsket område (pigger kan være 16 tommer fra hverandre).
- * Use un buscador de postes para ubicar dos (o más) postes dentro del área deseada (los postes pueden estar a 16 pulgadas de distancia de otro).
- * Använd en stud finder för att hitta två (eller fler) dubbar i önskat område (dubbar kan vara 16 tum från varandra).
- * Use um localizador de pinos para localizar dois (ou mais) pinos na área desejada (os pinos podem estar a 40 cm de distância).

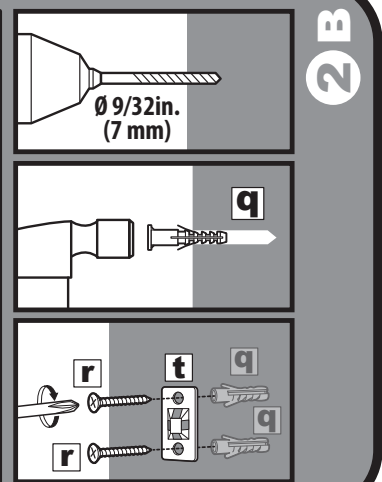
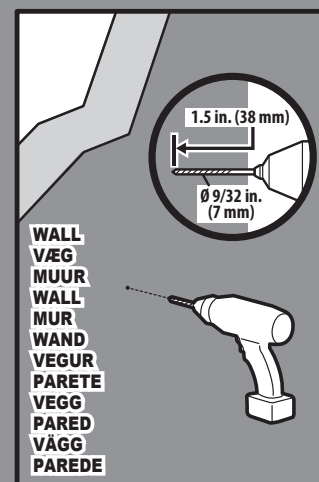
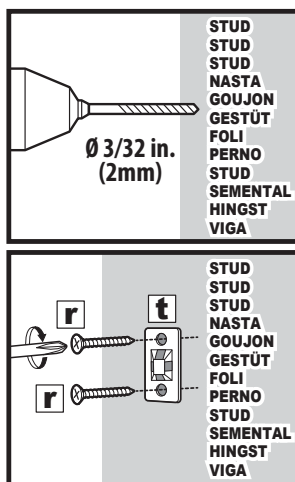
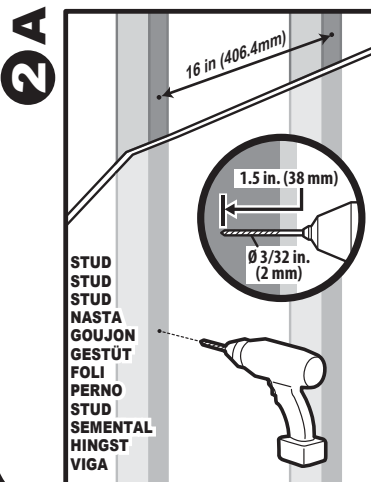
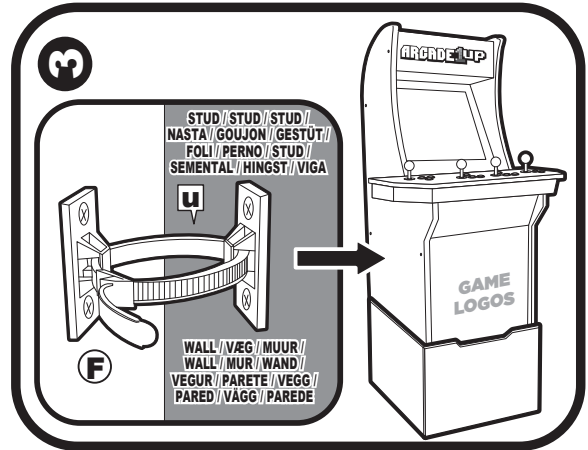

TASTEMAKERS, LLC.

589 Eighth Avenue, 3rd Floor, New York, NY 10018

F.P.L.T.W.F. 05.20.20