

TRANSMITTER AND RECEIVER/ESC DIAGRAMS

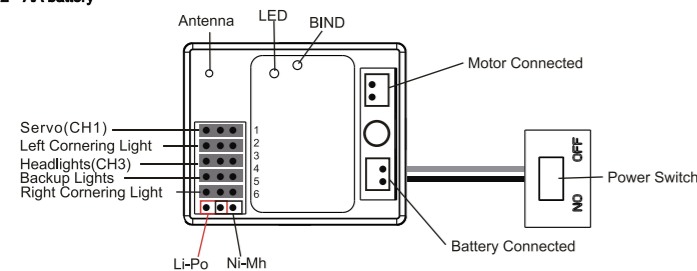
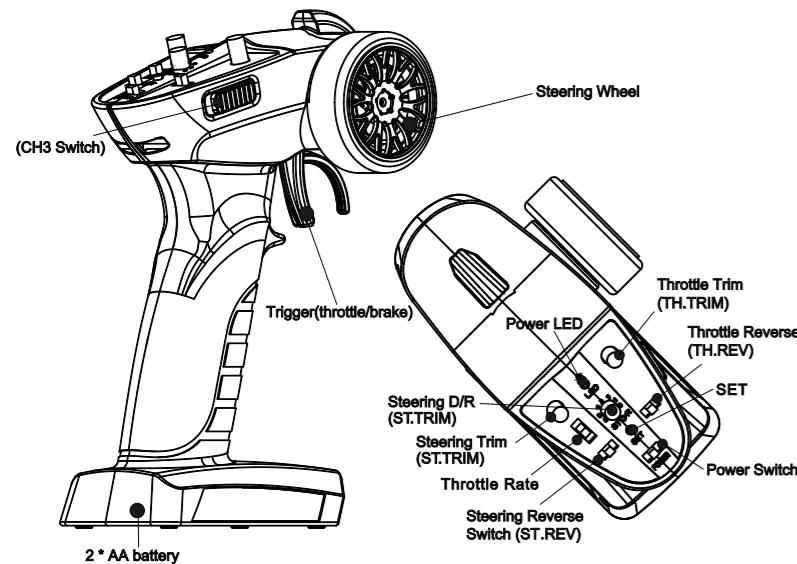

Three Settings Lighting System
 -Constant
 -Slow Flash
 -Strobe

To use: - Push switch towards steering wheel to turn on. Push switch in opposite direction to turn off. Cycle through using the same instruction to the desired light setting.

Automatic Light Operations

- The following light functions are automatic when lights are on.
- Turn right - Red right blinker activates
- Turn left - Red left blinker activates
- Driving - Red Rear taillights on
- Reverse - White reverse lights activate and red lights turn off.

Automatic Light Operations Troubleshoot

If your lights are not working according to your transmitter input, the plugs are in the incorrect position. Please see ESC guide for proper placement of plugs.

FCC Statement FCC ID: T-8198A

This device complies with part 15 of the FCC rules. Operation is subject to the following two conditions: (1) This device may not cause harmful interference, and (2) this device must accept any interference received, including interference that may cause undesired operation.

CAUTION: Changes or modifications not expressly approved by the party responsible for compliance could void the user's authority to operate the equipment.

This product contains a radio transmitter with wireless technology which has been tested and found to be compliant with the applicable regulations governing a radio transmitter in the 2.400GHz to 2.4835GHz frequency range. This equipment has been tested and found to comply with the limits for Part 15 of the FCC rule.

These limits are designed to provide reasonable protection against harmful interference in a residential installation.

This equipment generates, uses and can radiate radio frequency energy and, if not installed and used in accordance with the instructions, may cause harmful interference to radio communications.

However, there is no guarantee that interference will not occur in a particular installation. If this equipment does cause harmful interference to radio or television reception, which can be determined by turning the equipment off and on, the user is encouraged to try to correct the interference by one or more of the following measures:

- Reorient or relocate the receiving antenna.
- Increase the separation between the equipment and receiver.
- Connect the equipment to an outlet on a circuit different from that to which the receiver is connected.

CE EU Compliance Statement: This product is in compliance with the essential requirements and other relevant provisions of the RED and EMC Directives.

Instructions for disposal of WEEE by users in the European Union
 This product must not be disposed of with other waste. Instead, it is the user's responsibility to dispose of their waste equipment by handing it over to a designated collection point for the recycling of waste electrical and electronic equipment. The separate collection and recycling of your waste equipment at the time of disposal will help to conserve natural resources and ensure that it is recycled in a manner that protects human health and the environment. For more information about where you can drop off your waste equipment for recycling, please contact your local city office, your household waste disposal service or where you purchased the product.

TIPS

For more information on operating the car, the full manual can be found on the official website at www.pandahobby.com



QUICK START

TETRA18

1/18th Scale Crawler
READY-TO-RUN

All instructions and precautions outlined in this Quick Start should be strictly followed to ensure safe operation of your model. This model is not intended for use by children under 14 years of age without the supervision of a responsible and knowledgeable adult.

We want you to safely enjoy your new model. Operate your model sensibly and with care, and it will be exciting, safe, and fun for you and those around you. Failure to operate your model in a safe and responsible manner may result in property damage and serious injury. The precautions outlined in this Quick Start should be strictly followed to help ensure safe operation. You alone must see that the instructions are followed and the precautions are adhered to.

IMPORTANT POINTS TO REMEMBER

- Your model is not intended for use on public roads or congested areas where its operation can conflict with or disrupt pedestrian or vehicular traffic.
- Never, under any circumstances, operate the model in crowds of people. Your model is fast and could cause injury if allowed to collide with anyone.
- Because your model is controlled by radio, it is subject to radio interference from many sources that are beyond your control. Since radio interference can cause momentary losses of radio control, always allow a safety margin in all directions around the model in order to prevent collisions.
- The motor and battery can become hot during use. Always use caution in these areas.
- Don't operate your model at night, or anytime your line of sight to the model may be obstructed or impaired in any way.

ESC (SPEED CONTROLLER)

- **Disconnect the Battery:** Always disconnect the battery from the model when not in use.
- **Transmitter on First:** Switch on your transmitter first before switching on the speed control to prevent runaways and erratic performance.
- **Don't Get Burnt:** The motor can become extremely hot during use, so be careful not to touch it until it is cool. Make sure there is adequate airflow to the motor.
- **Use the Factory-Installed Connectors:** Do not change the battery connector. Improper wiring can cause fire or damage to the ESC.
- **Insulate the Wires:** Always insulate exposed or damaged wiring with heat shrink tubing to prevent short circuits. More information please refer to your ESC instruction manual.

BOX CONTENTS

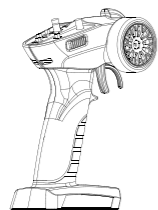
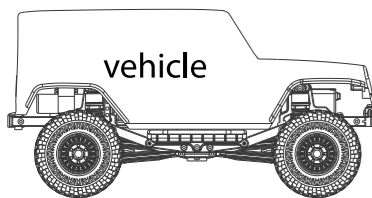

2.4Ghz 3ch Full Function Radio



QUICK START



Sticker

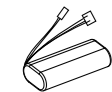

Vehicle Battery

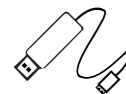

USB Charger



Hex Wrench 1.5mm



Cross wrench



AA Alkaline Dry Batteries



Spring Clips thin x 4
Spring Clips thick x 4

2

CHARGING INSTRUCTIONS

This is a guide for the care and usage of the charger and battery that comes with the vehicle.

CAUTION: The PHTC636082 charger is for use with 2-cell 7.4 volt batteries ONLY and must not be used with any other type of battery.

CAUTION: Never leave battery unattended while charging. Always disconnect the battery and store in a safe container.

CAUTION: Never store battery in your car or direct sunlight. Excessive heat may damage batteries and cause the battery to malfunction.

CAUTION: Never charge the battery if it is damaged in any way. Always check for loose wires, if it is puffy or wet after each use.

Remove the battery from the vehicle before charging.

- Place the battery on a fire-resistant surface away from combustible material.
- Keep the battery and charger away from water and other fluids. Never charge battery unattended.

1. Connect the USB connector to a PC USB port or to a USB AC wall adapter. The Red LED should be lit and solid.
2. Connect the battery to the JST connector on the charger. The Red LED should be lit and stay solid, and the Green LED should Flash to indicate charging has commenced. The charger will automatically begin the charging process. When the Red LED and the Green LED are both solid, the battery is fully charged.

When using the PHTC636082 charger, the PHTC636081 battery should fully charge in 1 hour.

GETTING STARTED

1. Install the battery.

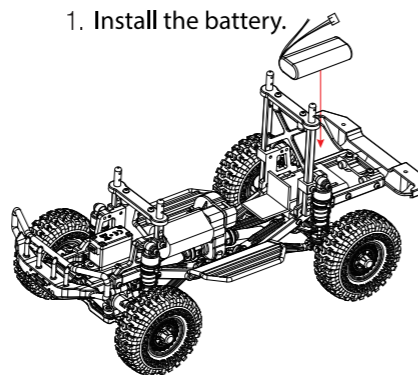

3

- 2.

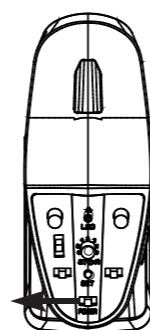

Turn on the transmitter.

3. Connect the battery to the ESC

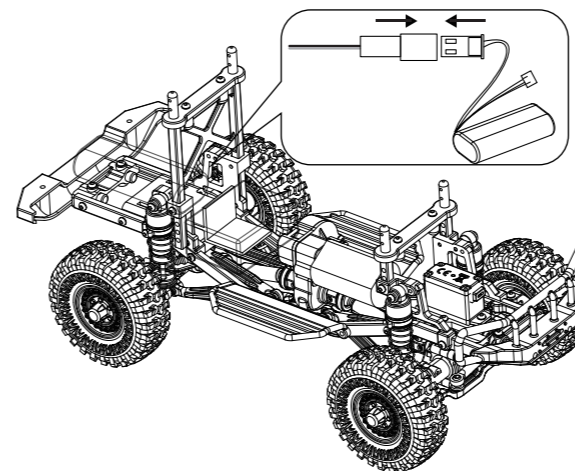

RADIO SYSTEM SPECIFICATIONS

Transmitter
Model: T-8198A
FHSS Output Power: <50mW
Operating Voltage: 2.4-3.2V
Power Supply: 2 Cell Alkaline
Frequency/Modulation Type:
2.4GHz FHSS

Receiver
Model: RX-18
Frequency: 2.4GHz FHSS
Operating Voltage: 6V-7.4V
Dimensions: 38.2*31.2*14mm
Low Battery Voltage Cutoff:
Li-ion/Li-Po: 6.4V
Ni-Mh: 5.0V

4

INSTALLING TRANSMITTER BATTERIES

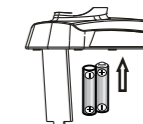

The Installing transmitter batteries should be below charging instructions and just after getting started.

CAUTION: If using rechargeable batteries, charge only rechargeable batteries. Charging non-rechargeable batteries may cause the batteries to burst, resulting in injury to persons and/or damage to property.

CAUTION: Risk of explosion if battery is replaced by an incorrect type. Dispose of used batteries according to national regulations.

BINDING

YOUR TETRA18 COMES BOUND AND READY TO OPERATE. IN THE EVENT THAT YOUR VEHICLE DOES NOT RESPOND TO THE TRANSMITTER, FOLLOW THE BINDING INSTRUCTIONS BELOW.

1. Turn off transmitter, power on the receiver and the receiver indicator will flash slowly.
2. Press receiver Bind key for 2 seconds, then release the button the indicator will flash fast.
3. Power on the transmitter. Once the light flashes, it indicates entering the binding process.
4. Once binding is successful, the LED of receiver and transmitter will stop flashing.

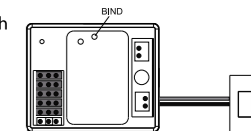

STEERING RATES & STEERING TRIM

Rates (dual rate) allow you to make adjustments to Steering, which allows you to access a different rate by turning. The Trim function allows electronic adjustment or centering of the steering servo to get the servo arm exactly perpendicular to the servo, or in the exact optimum desired position.



ST-TRIM



TH-TRIM

CHANGING THE THROTTLE LIMIT

L-Beginner Mode
Throttle limiting Switch: 30%

- Best for learning the basic functions of left, right, stop, brake and reverse
- For use in smaller areas
- Longest battery life

M-Best Overall Performance
Throttle limiting Switch: 60%

- Great top speed and acceleration
- Easier to accelerate in desired direction, especially on loose surfaces when compared to Maximum Speed setup
- Run time is greatly increased over Maximum Speed setup with minimal impact to speed

H-Maximum Speed
Throttle limiting Switch: 100%

- More capable of climbing over steep obstacles.
- Higher top speeds and maximum acceleration
- The most fun throttle position.

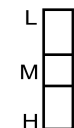

L
M
H

5