

**MOSO**  
**bamboo**  
the next  
flooring  
generation







**presenting  
the fastest  
growing plant  
in the world**



## stem to strip

After harvesting, the mature bamboo stems are split in longitudinal direction and the outer skin is removed.

The strips naturally have a light yellow colour (natural), but can be steamed for a light brown colour (caramel) or thermally treated for a dark brown colour (chocolate).

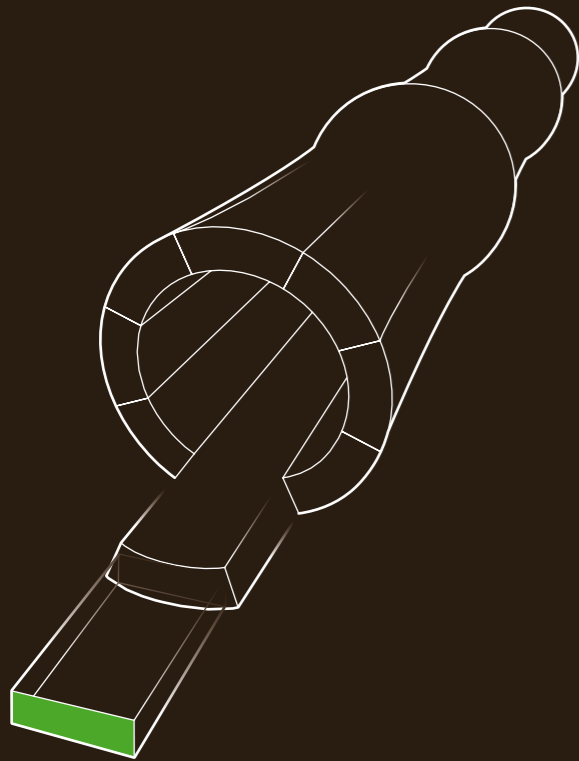

## strip to floor

After treating and drying, the strips are ready to be connected in several ways to make the final product:



### plain pressed

Strips are placed horizontally and glued together to create a wide line pattern with the characteristic bamboo nodes clearly visible.



### side pressed

Strips are placed vertically and glued together to create a narrow line pattern with the bamboo nodes visible in a subtle way.

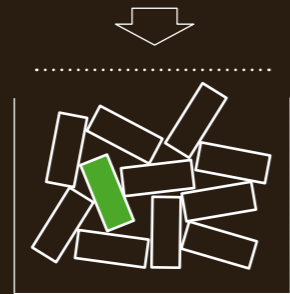

### high density

Strips are compressed and glued under high pressure, creating an elegant random line pattern. The result is a floor that is even harder than the best tropical hardwood species.



### extra hard

In the brochure the High Density variation is indicated by a hammer.

# ready for harvest after 5 years





**even  
harder  
than oak**



Although the bamboo species “Moso” is formally not a wood but a grass, it has excellent “hardwood like” characteristics: it is very **hard** and **durable**. Combined with the **high stability** (little shrink & swell) it is the perfect raw material for MOSO bamboo flooring.

Bamboo is an ‘**endless**’ **resource**: it grows very fast (up to 1 meter per day!) and as only the older stems are harvested, the younger bamboo receives more space for growth providing a higher yield. Because of its unique growing speed, combined with efficient production, MOSO bamboo actually absorbs more CO<sub>2</sub> than it releases during production and transport to the customer. All solid MOSO bamboo floors are therefore guaranteed **CO<sub>2</sub> neutral**.

MOSO floors are also a **healthy** choice as they are anti-static and anti-allergic.

The most striking feature of MOSO floors is certainly its **beauty**. Combined with the **vast choice** of different styles, configurations and colours, there is always a MOSO floor which will match your preferences.

As one of the pioneers in bamboo, MOSO has grown to become the European market leader. Our long experience (over 18 years) and strive for perfection have established our reputation of providing floors of the highest **quality**, with a product **guarantee** of up to 30 years.

# discover the bamboo benefits



#### CO<sub>2</sub> neutral

All solid MOSO bamboo floors are officially assessed to be CO<sub>2</sub> neutral or better over the complete lifecycle.



#### healthy

As a product from nature, MOSO bamboo floors are anti-static and anti-allergic, and thus facilitate a healthy indoor environment.



#### hard & durable

With a hardness and density similar to the best hardwood floors, MOSO bamboo floors are suitable for use even in heavy duty applications.



#### warranted quality

MOSO bamboo floors are of the highest quality and come with a product guarantee of up to 30 years.



#### endless resource

With a growing speed of up to 1 meter per day, Moso bamboo is the fastest growing plant on earth.



#### high stability

Because of the composition of individual strips, MOSO bamboo flooring will shrink and swell less than solid wood species, providing a more stable floor.



#### vast choice

MOSO bamboo floors are available in a large variety of configurations, styles and colours to cater to anyone's preferences.



#### natural beauty

Inspired by nature, MOSO bamboo floors are not only a conscious choice but also a stylish one.





## dynamic collection

The Dynamic Collection offers an **economical** range of **easy to install** floors, available in a **vast range of colours, sizes and styles** fitting the latest trends.

page 12

## eternal collection

The Eternal Collection features the **strongest** and most **robust** floors MOSO has to offer, suitable for use in even the **toughest commercial** applications.

page 22

## grand collection

The Grand Collection provides **long** and **wide** floors for a 'spacious' and luxurious look, with relatively **quick installation**.

page 30

## outdoor collection

The Outdoor Collection offers an **ecological, stable** and **durable** alternative for increasingly scarce tropical hardwood for exterior applications.

page 38

# dynamic collection

purebamboo  
topbamboo  
unibamboo  
flexbamboo

The Dynamic Collection provides an **economical** choice for customers that want a floor which is **easy to install**. Even though these are not the most expensive floors in the MOSO range, it does not mean they are of a lesser quality or offer less choice. In fact, the Dynamic Collection offers the **widest range** of possibilities in colour, size and style, fitting the latest trends.





# purebamboo

## Economical and 100% bamboo

MOSO Purebamboo is entirely made of solid bamboo, either with strips pressed together horizontally (plain pressed), vertically (side pressed) or compressed (high density). This floor type is a good solution when an economical but high performance bamboo floor is required. Purebamboo (in plain pressed version) was the first bamboo floor ever - all other bamboo floors have been derived from this classic version.

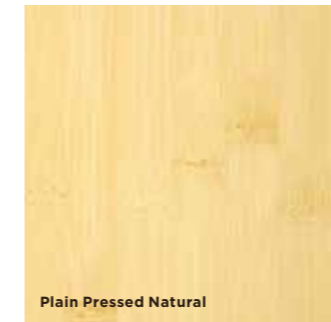

Plain Pressed Natural

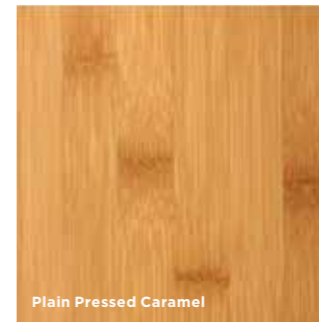

Plain Pressed Caramel

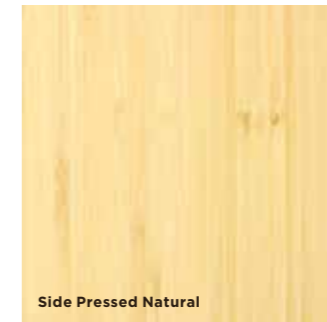

Side Pressed Natural

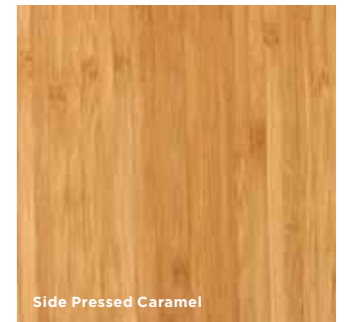

Side Pressed Caramel

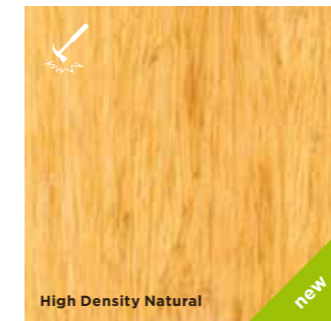

High Density Natural

new



High Density Caramel

shown on left page

new

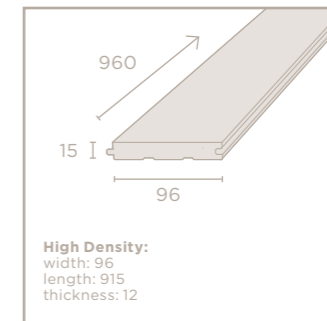

High Density:  
width: 96  
length: 915  
thickness: 12

For details about finishing & installation possibilities and technical properties please refer to pages 42 & 43.





# topbamboo

## Versatile and easy to install

MOSO Topbamboo consists of a top layer of bamboo combined with a HDF (High Density Fibre board) as the core and a softwood backing. Because of this construction, the product is very stable, while the click system makes it very easy to install (no glue needed). Topbamboo is available in a large variation of fashionable colours and finishes, including brushed and stained versions.

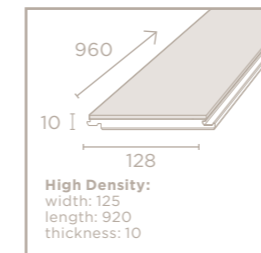
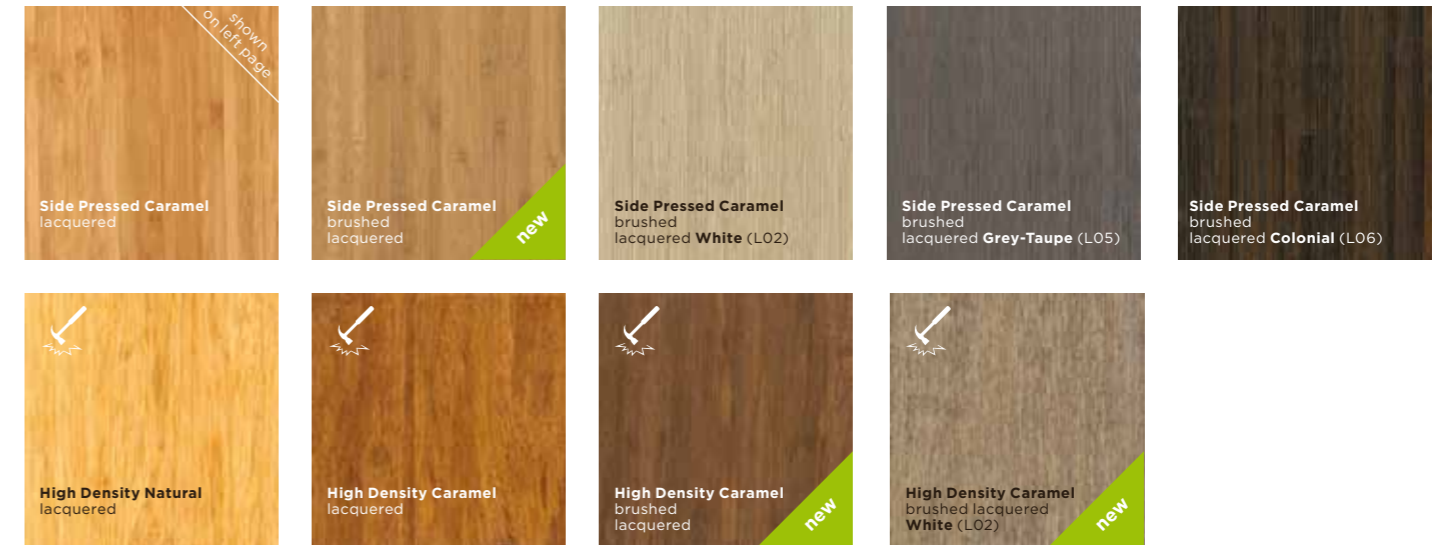

For details about finishing & installation possibilities and technical properties please refer to pages 42 & 43.





## unibamboo

### The power of thin

Unibamboo combines the virtues of carpet / vinyl with the charm of bamboo. In this innovative product, thin bamboo strips are pressed on a latex backing, providing a flexible, light, sound absorbing, economical flooring solution which is available in tiles or boards in a broad assortment of colours and sizes. Because of its limited thickness it is perfect for installation on top of existing floors, therefore ideal for renovation projects.

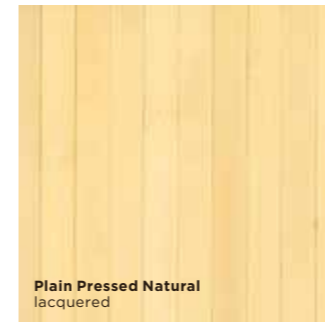

**Plain Pressed Natural**  
lacquered

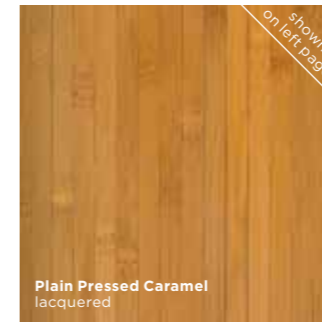

**Plain Pressed Caramel**  
lacquered



**Plain Pressed Caramel**  
stained-lacquered **White** (92)



**Plain Pressed Caramel**  
stained-lacquered **Black** (93)

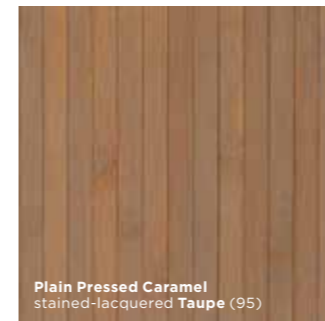

**Plain Pressed Caramel**  
stained-lacquered **Taupe** (95)



**Plain Pressed Caramel**  
stained-lacquered **Colonial** (96)

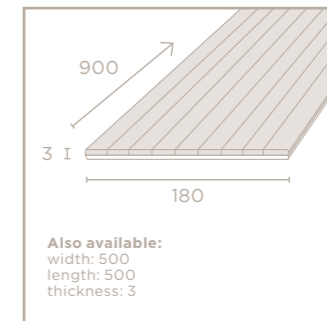

For details about finishing & installation possibilities and technical properties please refer to pages 42 & 43.





# flexbamboo

## Bamboo rolled into your room

MOSO Flexbamboo is made by connecting thin bamboo strips to a flexible latex backing and comes in rolls. The latex backing makes it very comfortable to walk on. Flexbamboo offers excellent sound absorption characteristics at a very economical price. The product is finished with a high quality UV cured oil (SAICOS®) and is available in seven trendy colours.

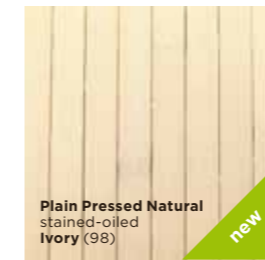

**Plain Pressed Natural**  
stained-oiled  
Ivory (98)

new

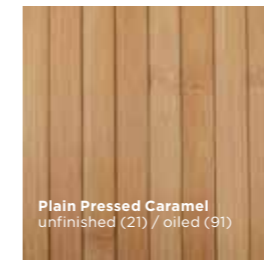

**Plain Pressed Caramel**  
unfinished (21) / oiled (91)



**Plain Pressed Caramel**  
stained-oiled  
Misty-White (92)

new

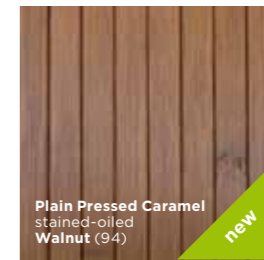

**Plain Pressed Caramel**  
stained-oiled  
Walnut (94)

new

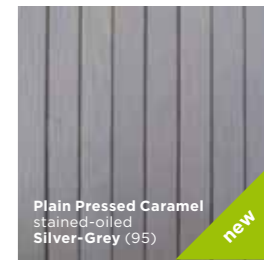

**Plain Pressed Caramel**  
stained-oiled  
Silver-Grey (95)

new

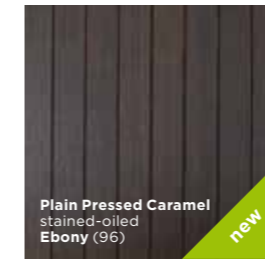

**Plain Pressed Caramel**  
stained-oiled  
Ebony (96)

new

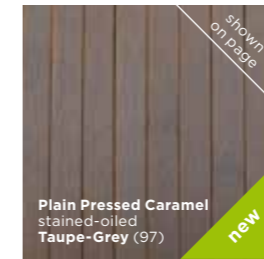

**Plain Pressed Caramel**  
stained-oiled  
Taupe-Grey (97)

new

shown  
on page

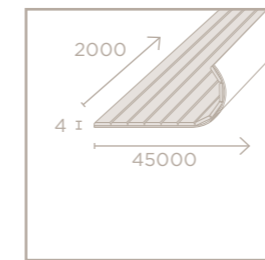

For details about finishing & installation possibilities and technical properties please refer to pages 42 & 43.



# eternal collection

The Eternal Collection provides the **strongest** and most **robust** floors in the MOSO assortment. For customers that are searching for a **lifelong** flooring solution, a floor from the Eternal Collection will be the best choice. MOSO Eternal floors are even suitable for use in the **toughest** applications for the **professional** market.

**bamboosupreme**  
**bambooforest**  
**bambooindustriale**





## bamboosupreme

Perfect compromise between durability and stability

MOSO Bamboo Supreme is made from two layers of bamboo, with a 4 mm toplayer and a cross pressed bamboo backing. The total thickness is 10 mm which is relatively thin compared to other wood floors. However, as with any wood species the basic rule is: the thicker, the less stable the wood (shrink/swell). The 10 mm thickness and 4 mm toplayer is an ideal compromise between durability and stability and therefore offers a perfect solution for heavy circumstances, like installation on floor heating and/or installation in heavy traffic areas.

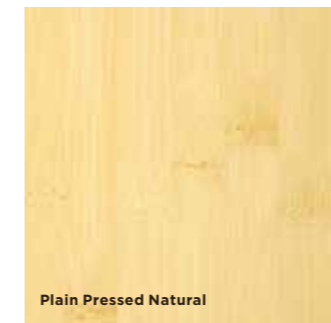

Plain Pressed Natural

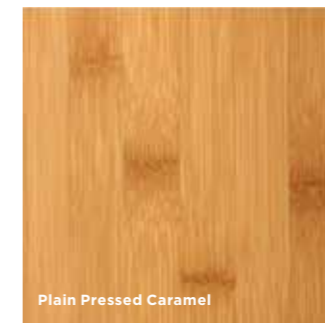

Plain Pressed Caramel

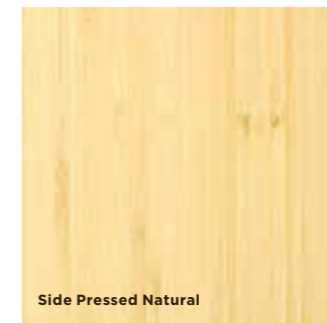

Side Pressed Natural

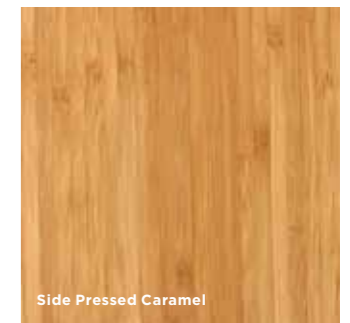

Side Pressed Caramel

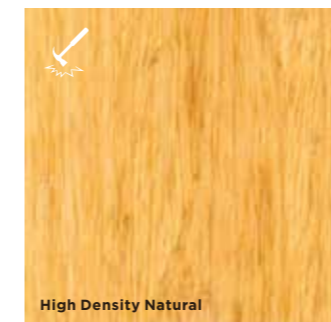

High Density Natural

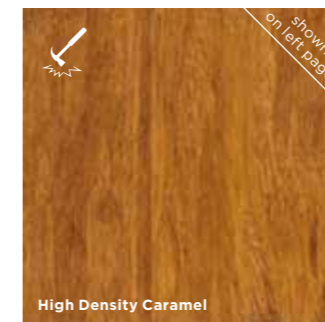

High Density Caramel

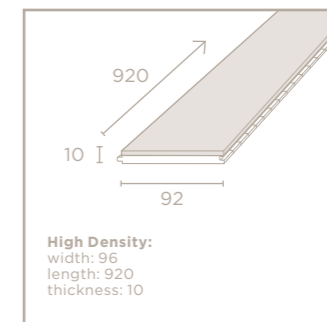

For details about finishing & installation possibilities and technical properties please refer to pages 42 & 43.





## bambooforest

### Bringing the bamboo forest to your floor

MOSO Bamboo Forest is the most authentic bamboo floor imaginable. For this unique product the bamboo stem is flattened with a special process to create the top layer of a three layer solid bamboo floor board. The result is a very robust floor with the natural beauty and original look of the bamboo plant. The surface of the floor consists of the stony bark of the bamboo stem, which is so hard and wear resistant that no oil or lacquer finish is required.

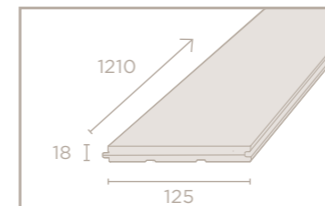
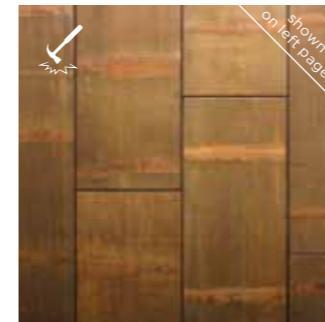

Also available:  
width: 97  
length: 970  
thickness: 18

For details about  
finishing &  
installation  
possibilities and  
technical properties  
please refer to  
pages 42 & 43.





## bambooindustriale

### Striking look and strength

MOSO Bamboo Industriale consists of small floor 'boards' made from short solid bamboo strips, creating the specific industrial look. The 'boards' are in fact blocks of strips bundled together with tape (so no glue is used in the product itself!). The floor installer glues them on the subfloor, sands off the tape, fills the gaps and finishes the surface. Being made of such small strips, the floor is very stable – making it the perfect solution for application on floor heating. This floor has the thickest wear layer of all MOSO floors: up to 15 mm!

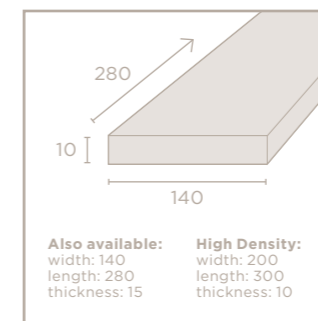
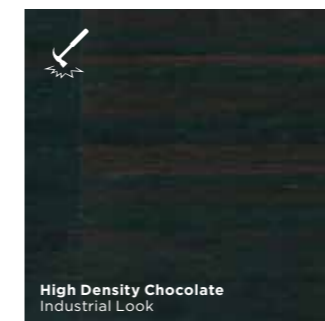
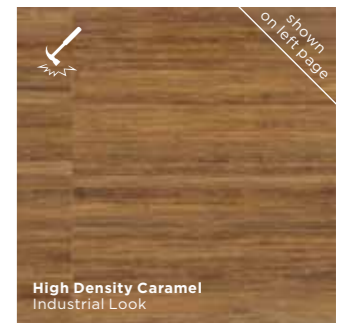
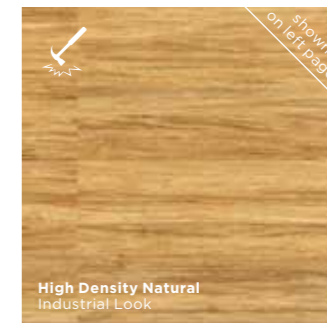
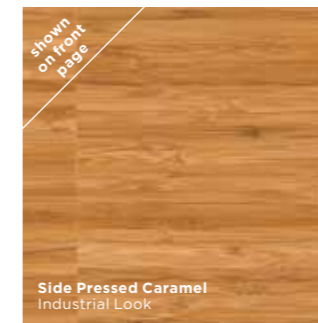
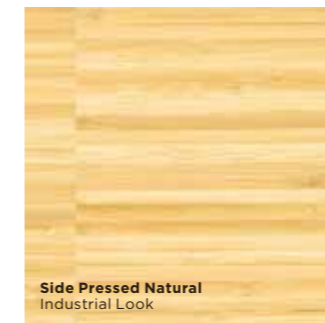

For details about finishing & installation possibilities and technical properties please refer to pages 42 & 43.

# grand collection

bambooeelite  
bambooplex  
bamboonoble

The Grand Collection was specially developed for customers that appreciate the aesthetics of **large boards** for a **spacious** and **exclusive** look. Because of the large size of the boards, the installation can be done relatively fast.





## bamboelite

Long and wide boards - 100% bamboo

MOSO Bamboo Elite is a floor board which is relatively long and wide (compared to other MOSO floors) and is made from three layers of solid bamboo. The middle layer of Bamboo Elite is pressed cross wise to maximise the stability.

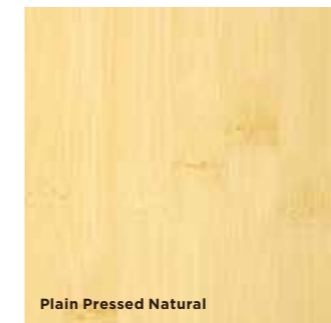

Plain Pressed Natural

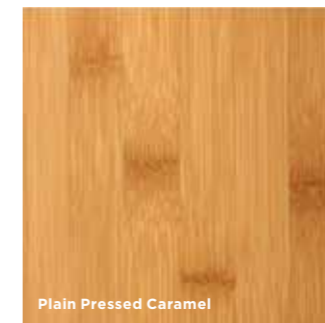

Plain Pressed Caramel

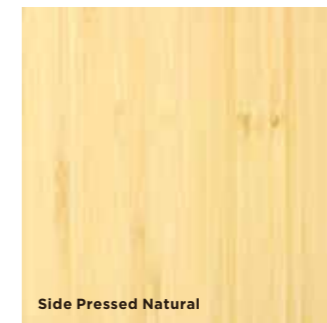

Side Pressed Natural

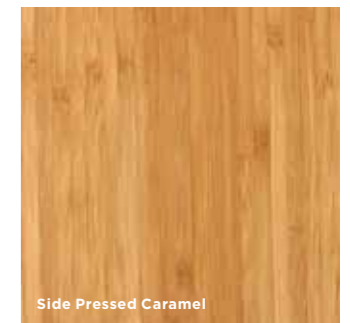

Side Pressed Caramel

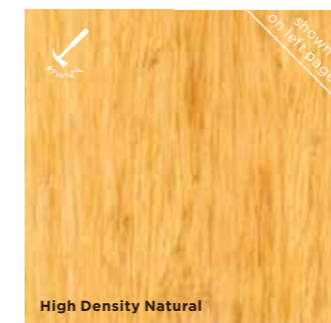

High Density Natural

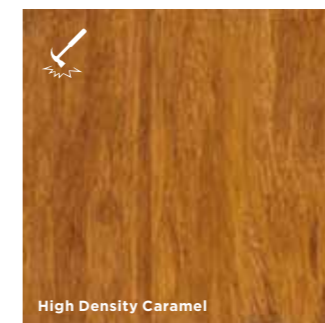

High Density Caramel

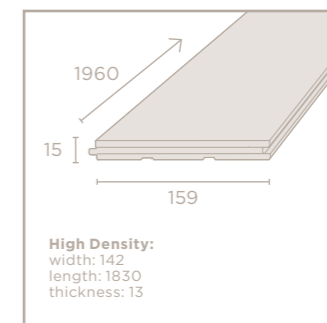

High Density:  
width: 142  
length: 1830  
thickness: 13

For details about finishing & installation possibilities and technical properties please refer to pages 42 & 43.





## bambooplex

### Long and wide boards with V-groove

MOSO Bamboo Plex is a long and wide floor board made from a thick bamboo top layer and a multiplex sub layer. With this construction, the floor board is very stable and with the thick top layer also very durable. The big bevel (on the length side) of the board creates a beautiful V-groove once installed.

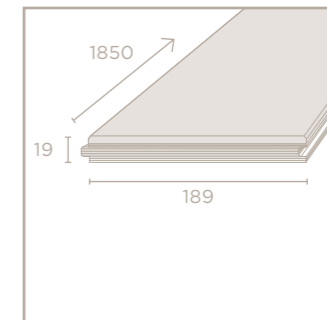
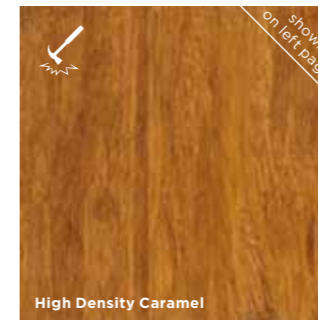
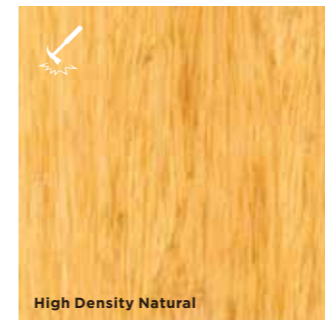

For details about finishing & installation possibilities and technical properties please refer to pages 42 & 43.





## bamboonoble

Long and wide with extra option: installation without glue

MOSO Bamboo Noble is, together with MOSO Bamboo Plex, the widest flooring board MOSO has to offer. MOSO Bamboo Noble consists of 3 layers, with a bamboo top layer. The other layers are made of soft wood, the middle layer being cross pressed to maximise stability. In addition to the normal tongue and groove connection, the boards are also available with a “click” system which facilitates installation without using glue.



**Plain Pressed Natural**  
only with click system



**Plain Pressed Caramel**



**Side Pressed Natural**  
only with click system

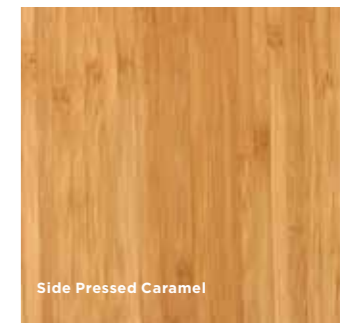

**Side Pressed Caramel**

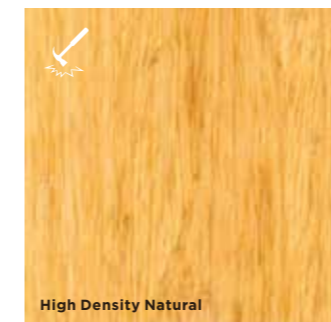

**High Density Natural**

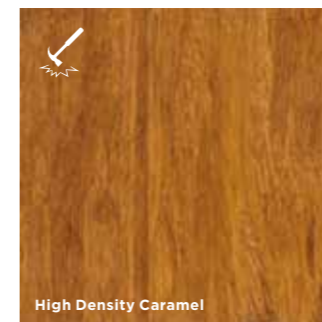

**High Density Caramel**

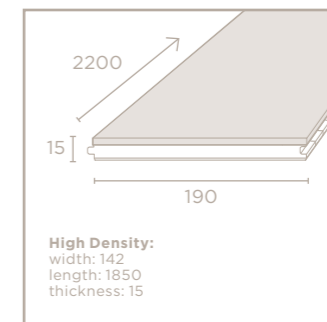

**High Density:**  
width: 142  
length: 1850  
thickness: 15

For details about finishing & installation possibilities and technical properties please refer to pages 42 & 43.

# outdoor collection

bamboox-treme

With the introduction of the Outdoor Collection, MOSO has developed a truly **ecological** and **durable** alternative for increasingly scarce tropical hardwood. MOSO uses a unique patented process to alter the **hardness, dimensional stability** and **durability** to a level **superior** to the best tropical hardwood species.



outdoor collection

## bamboox-treme

### The next generation in decking

MOSO Bamboo X-treme is a solid, high density bamboo board, made from compressed bamboo strips. Bamboo X-treme is suitable for outdoor applications, especially as decking. A special, patented heat treatment process provides Bamboo X-treme the highest durability class possible in the appropriate EU norms\* and increases the density - making it very hard. The special symmetrical shape of the sides offers the possibility to choose between either the ribbed or the flat surface, and allows for quick installation with fasteners. Like any untreated tropical hardwood species, when exposed to outdoor circumstances, Bamboo X-treme will turn grey over time creating a very natural look (see right bottom picture).

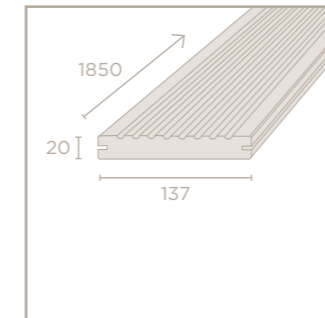
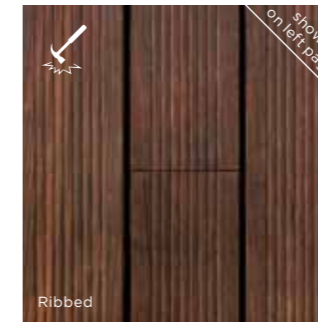

\*Class 1 for EN 350,  
Class 0 for EN 152  
and Class 4 for EN 335

For details about  
finishing & installation  
possibilities and technical  
properties please refer to  
pages 42 & 43.



dynamic collection

purebamboo



topbamboo



unibamboo



Board

flexbamboo



Tile

Style	purebamboo	topbamboo	unibamboo	flexbamboo
Plain Pressed (PP)	•	-	•	•
Side Pressed (SP)	•	•	-	-
High Density (HD)	•	•	-	-
<b>Dimensions (mm)</b>				
Thickness	15 (HD: 12)	10	3	3
Strip dimensions			2x15	2x15
Length	960 (HD: 915)	960 (HD: 920)	900	500
Width	96	128 (HD: 125)	180	500
2000				
<b>Colours</b>				
Natural	•	•	•	•
Caramel	•	•	•	•
Chocolate	-	-	-	-
Additional Colours	-	3 <sup>3)</sup>	4 <sup>4)</sup>	6 <sup>5)</sup>
<b>Finish</b>				
Unfinished	•	-	-	•
Oil	-	-	-	Saicos <sup>5)</sup>
Lacquer	Bona 80 gr/m <sup>22)</sup>	Treffert 80 gr/m <sup>2</sup>	Bona 110 gr/m <sup>2</sup>	Bona 110 gr/m <sup>2</sup>
Stained-Lacquered	-	Treffert 80 gr/m <sup>2</sup>	Bona 110 gr/m <sup>2</sup>	Bona 110 gr/m <sup>2</sup>
Brushed	-	•	-	-
Flat / Ribbed				
<b>Edges</b>				
Unfinished	Sharp edged	-	-	-
Oil	-	-	-	Micro bevel 2 sides
Lacquer	Micro bevel 4 sides	Micro bevel 4 sides	Micro bevel 4 sides	Micro bevel 2 sides
-				
<b>Properties &amp; certification</b>				
Hardness (Brinell kg/mm <sup>2</sup> )	>4 (HD: >9.5)	>4 (HD: >9.5)	>3	>3
CO <sub>2</sub> neutral	•			
FSC® certified				
Guarantee (years)	30	10	10	10
CE marked	•	•	-	-
<b>Installation method</b>				
Fully glued	++	+	++	++
Floating	+	++	-	-
Floor heating <sup>1)</sup>	+	+	-	-
With Clips (Grooved)				

++ advised  
+ possible  
+/- limited possible  
- not possible

<sup>1)</sup> See pdf "MOSO floorheating" (www.moso.eu)  
<sup>2)</sup> Plain and Side Pressed style: lacquered with Bona 80 gr/m<sup>2</sup>  
High density style: lacquered with Treffert 80 gr/m<sup>2</sup>  
<sup>3)</sup> There are 3 additional colours available on Topbamboo:  
L02=White, L05=Grey-Taupe, L06=Colonial

<sup>4)</sup> There are 4 additional colours available on Unibamboo:  
92=White, 93=Black, 95=Taupe, 96=Colonial  
<sup>5)</sup> There are 6 additional colours (Saicos<sup>®</sup>) available on  
Flexbamboo: 98=Ivory, 92=Misty-White, 94=Walnut,  
95=Silver-Grey, 96=Ebony, 97=Taupe-Grey

eternal collection

bamboosupreme

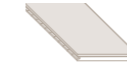

bambooforest



bambooindustriale



grand collection

bambooeelite



bambooplex

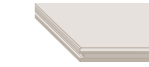

bamboonoble

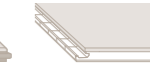

outdoor collection

bamboox-treme

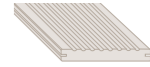

bamboosupreme	bambooforest	bambooindustriale	bambooeelite	bambooplex	bamboonoble	bamboox-treme
•		-	•	-	•	-
•		•	•	-	•	-
•		•	•	•	•	•
10	18	10 / 15 <sup>7)</sup>	15 (HD: 13)	19	15	20
970 (HD: 920)	1210 / 970	280 (HD: 300)	1960 (HD: 1830)	1850	2200 (HD: 1850)	1850
95 (HD: 96)	125 / 97	140 (HD: 200)	159 (HD: 142)	189	190 (HD: 142)	137
•		•	•	•	•	•
•		•	•	•	•	•
-		• <sup>8)</sup>	-	-	-	• <sup>11)</sup>
-		-	-	-	-	-
•	•	•	•	-	-	•
Woca	-	-	Woca <sup>9)</sup>	Woca	Woca <sup>10)</sup>	Woca <sup>12)</sup>
Bona 125 gr/m <sup>2 6)</sup>	-	-	Bona 80 gr/m <sup>2 9)</sup>	-	Bona 80 gr/m <sup>2 10)</sup>	-
-	-	-	-	-	-	-
-	-	-	-	-	-	-
						• <sup>13)</sup>
Sharp edged	Micro Bevel	Sharp edged	Sharp edged	-	-	Bevel 4 sides
Sharp edged	-	-	Micro bevel	Bevel 2 sides	Sharp edged	Bevel 4 sides
Sharp edged <sup>6)</sup>	-	-	Micro bevel 4 sides	-	Sharp edged <sup>10)</sup>	-
>4 (HD: >9.5)	>9.5	>4 (HD: >9.5)	>4 (HD: >9.5)	>9.5	>4 (HD: >9.5)	>9.5
•	•	•	•	•	•	•
•		•				•
30	30	30	30	30	30	10
•	•	•	•	•	•	
++	++	++	++	++	+	
-	+	-	+	++	++	
++	+	++	+	+	+	
						++ <sup>14)</sup>

<sup>6)</sup> High density style: lacquered with Bona Naturale (extra matt) 225 gr/m<sup>2</sup>, with nano bevel  
<sup>7)</sup> High density style: not available in 15 mm thickness  
<sup>8)</sup> Chocolate colour only available in high density style  
<sup>9)</sup> High density style: lacquered with Bona Naturale (extra matt) 125 gr/m<sup>2</sup> / Pre-oiled with Woca

<sup>10)</sup> High density style: lacquered with Bona 80 gr/m<sup>2</sup>  
High density style: equipped with "nano bevel", approx. 0.1 mm (barely visible)  
<sup>11)</sup> Colour can change over time depending on the maintenance schedule  
<sup>12)</sup> Oil applied on both sides  
<sup>13)</sup> One side flat, one side ribbed: both sides can be used  
<sup>14)</sup> Can also be screwed



## accessories

MOSO offers a full array of bamboo accessories for a sophisticated finishing touch to the MOSO floor of your choice.

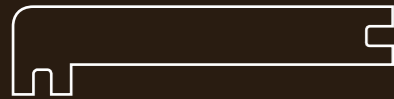

**stair nose**  
10, 13 or 15 mm thickness  
Available in various finishes  
Bamboo Forest: 18 mm thickness

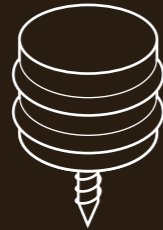

**door stopper**  
32 mm diameter  
34 mm high



**radiator pipe rosette**  
50 mm (diameter) x 18 mm (high), 16 mm hole  
55 mm (diameter) x 20 mm (high), 22 mm hole



**skirting strip**  
25x5mm  
attach to floor



**solid skirting board**  
68/50 x 15mm  
attach to wall  
Bamboo Forest: 60x18 mm



**veneered skirting board**  
40x22 mm  
attach to wall



**veneered skirting board**  
45x22 mm  
attach to wall



**veneered skirting board**  
60x15 mm  
attach to wall



## about MOSO

MOSO International was founded in the Netherlands in 1997. Since then MOSO has evolved to become the unchallenged **European market leader** in the development of innovative and sustainable bamboo products for interior and exterior applications.

There is no other company worldwide with an equal - and still expanding - **broad assortment** in **high quality** bamboo products, permanently available from stock either in Barcelona (office MOSO Europe), Milan (office MOSO Italy), Hangzhou (office MOSO China) or at the main office near Amsterdam (MOSO International). Furthermore, MOSO works with several partner companies and leading distributors worldwide to **guarantee the availability** of MOSO products in each region.

Besides the product groups MOSO Bamboo Flooring and MOSO Outdoor, MOSO offers a very broad assortment of **bamboo panels, veneer and beams** in various sizes, thicknesses, colours and textures. These panelling products are used worldwide in various applications ranging from wall covering, ceilings, window frames, doors, stairs, furniture and kitchens, providing an ideal combination with the MOSO flooring assortment.

Furthermore, because of its expertise, MOSO is able to develop **unique, customized bamboo solutions** for industrial clients meeting exceptionally stringent requirements. Through its experience, innovative attitude and world-wide network, MOSO is recognised as the **global A-brand** in bamboo products. The proof is the impressive line of references such as Madrid Airport, BMW, Philips, Bodyshop, Starbucks, Shell, Artek, Guggenheim Museum, Dell, Toyota, Crocs, ING, Salomon Skis, Carlton Hotel, Randstad, Rabobank, United Nations (FAO), Mercedes and CitizenM Hotels. For an overview of our references and clients please refer to our website: **www.moso.eu**



# MOSO bamboo flooring: a sustainable choice!

To determine the eco-impact of a floor, every phase of the life cycle should be taken into account. MOSO bamboo flooring offers clear sustainability advantages in each phase and is even proven CO<sub>2</sub> neutral over the full life cycle!

## growth phase

- ✓ Made from the extremely rapidly renewable giant bamboo species "Moso", renowned for its CO<sub>2</sub> absorbing and O<sub>2</sub> producing capacity.
- ✓ Abundantly available in China (approx. 7 mio ha) and always sourced from sustainably managed forests and plantations.
- ✓ The Moso bamboo plant consists of multiple stems. As a result, several stems may be harvested each year without killing the mother plant.
- ✓ **Optional:** MOSO bamboo FSC®-certified (most important ecolabel for sustainable wood sourcing).



growth phase

## production phase

- ✓ All MOSO bamboo floors are made in production facilities that are ISO 9001 and ISO 14001 (important quality standards) certified.
- ✓ **Optional:** use of eco-friendly adhesive with no added formaldehyde, complying with the strictest emissions norm: EO (EU requisite = E1).



production phase



end of life phase



use phase

## end of life phase

- ✓ As a non toxic, natural material, MOSO bamboo floors offer no restrictions in the end-of-life phase.
- ✓ If maintained well, MOSO bamboo flooring may be reused in similar applications (upcycling). If this is not possible, MOSO flooring may be safely used as input material for the chipboard industry (downcycling).
- ✓ If up- or downcycling is not possible, it is recommended to use the bamboo material as sustainable substitute for fossil fuels in a biomass energy plant for the production of green energy.

## use phase

- ✓ Durable = Sustainable: because of the high hardness, density and stability, MOSO bamboo flooring lasts very long (less replacement) even in tough circumstances.
- ✓ Proven Quality: all MOSO bamboo flooring products are CE marked and guaranteed up to 30 years.
- ✓ Healthy indoor climate: very low emissions of volatile organic compounds (VOCs). MOSO floors have been rated A and A+ in France with respect to VOC emissions: the best classification possible!
- ✓ Extra credits for sustainable building eco-labels, such as BREEAM and LEED.



# carbon footprint

**MOSO bamboo flooring: CO<sub>2</sub> neutral or better over full life cycle** - Life-cycle Assessment (ISO 14040/44) and carbon footprint studies executed by Delft University of Technology have confirmed that all assessed MOSO products (all solid bamboo flooring, decking, beams, panels and veneer) are CO<sub>2</sub> neutral or better over the full life cycle. For more information about the official report please refer to our website: [www.moso.eu](http://www.moso.eu)

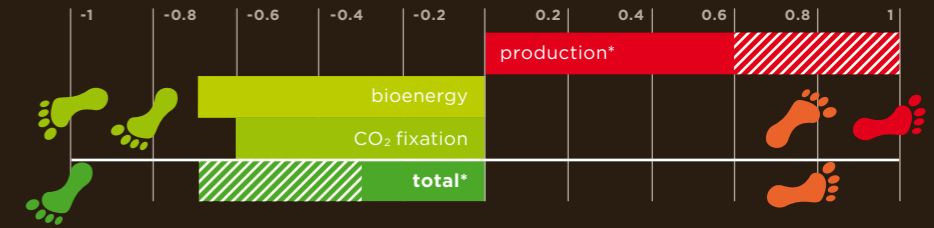

in CO<sub>2</sub> eq/kg

\* result depending on MOSO floor assessed

# unsurpassed growing speed

**Moso bamboo: the fastest growing plant in the world** - Because of the fast growth, giant bamboo is managed as an agricultural crop: the annual harvest of the 4-5 year old stems – compared to 80 years for tropical hardwood! - provides a steady annual income to farmers and stimulates the bamboo plant to reproduce even faster. Therefore, in contrast to tropical hardwood, there is no deforestation taking place for production of MOSO bamboo flooring.

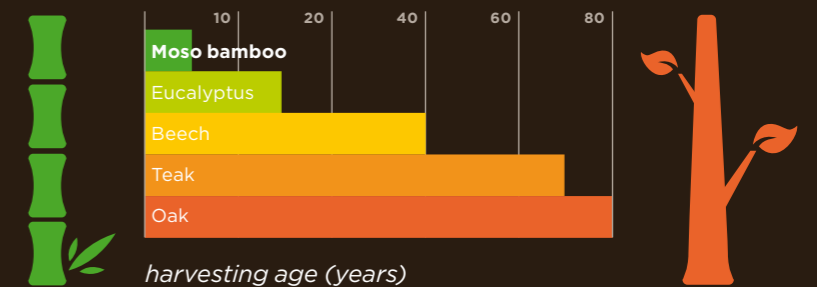



# MOSO world leading in bamboo

ceiling panel

Adolfo Suarez  
International Airport  
Madrid, Spain

design: Rogers Stirk  
Harbour + Partners  
scope: 200.000m<sup>2</sup>





**Aveda educational center**  
Milano (April Architects)



**lounge chair**  
Worldwide (Tejo Remy & René Veenhuizen)



**Bodyshop stores**  
Europe



**BMW dashboard**  
Worldwide



**Campus Palmas Altas**  
Sevilla (Rogers Stirk Harbour + Partners, Vidal)



**office van Leeuwen Buizen**  
The Netherlands (Lugten Malschaert Architects)



**CitizenM hotel**  
Amsterdam (Concrete Architects Amsterdam)



**Guggenheim museum**  
Bilbao (Cesar Caicoya - Idom Architects)



**World financial center**  
Shanghai (KPF Architects)



**Lentini's restaurant**  
Torino (F&F Studio)



**Bata shops**  
France



**Loyens & Loeff lawyers**  
Rotterdam (Fokkema & Partners)



**headoffice Van Oord**  
Rotterdam (INBO Architects)



**Wuxi Grand Theatre**  
Wuxi China (Pekka Salminen)



**Toyota Europe**  
Brussels (Bureau ASSAR)



**Virgin gym**  
Zaragoza



**Jumbo headoffice**  
Rotterdam (MVSA Architects)



**Campus Hotel Hertenstein**  
Weggis, Switzerland (Luc Richard)



Spain, France, Portugal, Italy, Africa  
and South-America:

**Moso Europe SLU**

Edificio CIM Vallès C/ Calderín, s/n - 7-5  
08130 Sta Perpetua de la Mogoda  
(Barcelona) Spain  
T +34 (0)93 5749610  
[www.moso.eu](http://www.moso.eu)

Other countries:

**Moso International BV**

De Marowijne 43  
1689 AR Zwaag  
the Netherlands  
T +31 (0)229 265732  
[www.moso.eu](http://www.moso.eu)



**bamboo  
products**