



MODEL: PTL2450



Plane Chart:

Unit:(mm) Terminal type:(LC4)

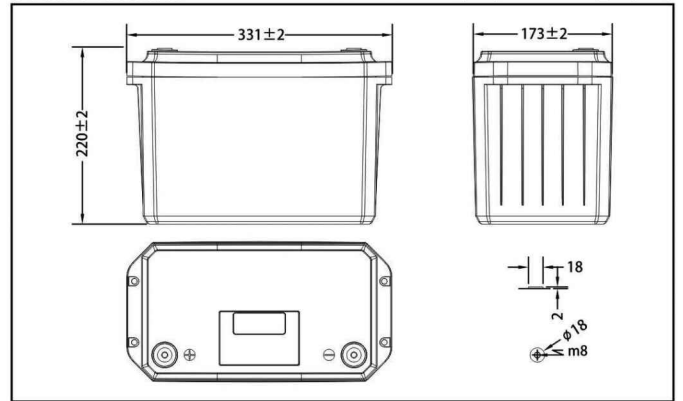

Parameter Chart:

Capacity(25°C)	10 hours rate (5A)	50Ah
Internal Resistance	Full Charged Battery 25°C	≤30mΩ
Capacity Affected By Temperature	40°C	101%
	25°C	100%
	0°C	93%
	-20°C	65%
Residual Capacity (25°C)	Capacity After 3 Months Storage	87%
	Capacity After 6 Months Storage	74%
	Capacity After 12 Months Storage	50%
Charge (Constant Voltage)	Cycle (25°C)	Initial Charging Current Less Than 30A Voltage 28.8~29.2V
	Float (25°C)	Charge Voltage 27.2~27.6V
Discharge Current (25°C)	35A (Max. continuous); 52.5A (5 Seconds)	
Weight (Approx)		11.30Kg

Discharge Current 25°C

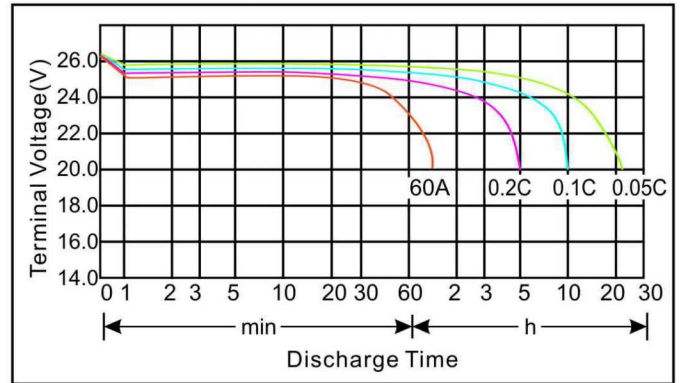

Cycle service life in relation to the depth of discharge

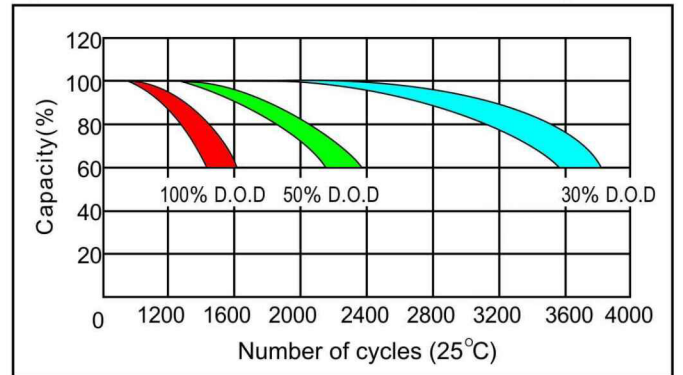

Residual Capacity

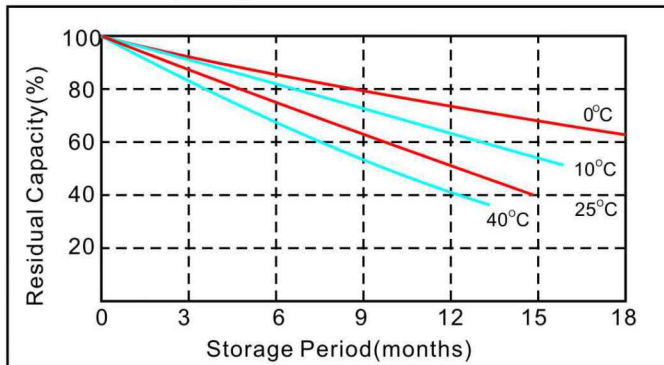

Constant Current Discharge Characteristics (A, 25°C)

F.V/Time	1.6h	2h	2.5h	3h	5h	8h	10h	21h
20V	35	25	20	16.6	10	6.3	5	2.4

Constant Power Discharge Characteristics (Watt, 25°C)

F.V/Time	1.6h	2h	2.5h	3h	5h	8h	10h	21h
20V	420	300	240	200	120	75	60	29

Capacity Factors With Different Temperature

Battery Type	-20°C	-10°C	0°C	5°C	10°C	20°C	25°C	30°C	40°C	45°C
Li Battery	24V	65%	82%	93%	95%	97%	100%	100%	101%	102%

Constant voltage charging characteristics

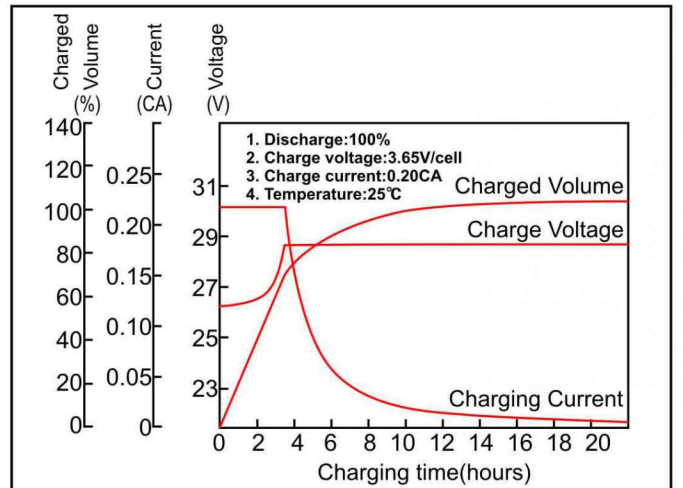

★The above are average and data obtained from the first 3 charge/discharge cycles. These are not minimum values.