



An IMCI Company  
**BIJUR DELIMON**  
INTERNATIONAL



# SINGLINE<sup>®</sup> COMPONENTS

PUMPS, VALVES, CONTROLLERS

BULLETIN SL2800

## Contents

Introduction .....	2
M2500G Series Valves .....	3
1000 Series Valves.....	5
3000 Series Valves.....	7
FD Valves and Sureshot Kits .....	9
Singline Valve Assembly Ordering	
Instructions .....	10
Singline Valve Accessories.....	11
Manual/Mechanical Pumps.....	15
TP Air/Hydraulic Operated Pumps .....	16
T30, T32 Oil/Grease Reservoirs .....	17
Ordering Info for Complete Air/Hydraulic Pumps Packages .....	18
Surematic Pumps.....	19
GPO Motor Driven Oil Pump Packages....	20
Dynamis/Dynamis Maxx Pumps .....	21
Multiport Motor Driven Grease Pump Packages .....	22
Air & Electric Grease Drum Pumps .....	25
Air/Oil.....	26
Lube Point Monitor .....	28
Strainers and Timers .....	29
System Controls .....	30

MODULAR CONSTRUCTION,  
EASY INSTALLATION &  
MAINTENANCE,  
INDIVIDUAL ZONE  
CONTROL, ZINC-NICKEL  
PLATING

*Illustrations and specifications are not binding in detail. Designs are subject to modification and improvement without notice.*

# Introduction

## Description

The series 1000, M2500G, and 3000 Progressive Divider Valve Manifolds distribute and proportion incoming oil or grease to bearing points. A typical divider valve manifold consists of an inlet section, three to ten valves and an end section. One assembly can serve up to a maximum of 20 lubrication points. Individual divider valve blocks have a discharge piston and built-in outlet check valves. Blocks are offered in various output sizes. The discharge capacity of a block is determined by varying the piston diameter in the valve block.

Twin valve blocks have two outlets located at each end of the assembly and supply rated discharge from each of the two outlets during one complete valve cycle. Single outlet blocks have one end outlet plugged and supply twice the rated output to the open outlet. External cross porting of adjacent valves can be achieved with a cross port kit to combine outputs.

## Progressive Divider Valve Operating Sequence

Individual valve blocks operate in a "Progressive" sequence. During operation, the piston within the block must complete a full discharge cycle before another piston begins operation. As long as lubricant is supplied under pressure to the inlet section of the divider, manifold valve blocks will continue to operate in a progressive manner.

When lubricant flow is interrupted to the inlet block, piston movement stops. When flow resumes, piston movement commences at the same point in the discharge cycle. Feed lines deliver lubricant from the valve block to individual lube points. Should a discharge line become blocked, it will stop all the valves operating. Indicators are available to alert a blockage.

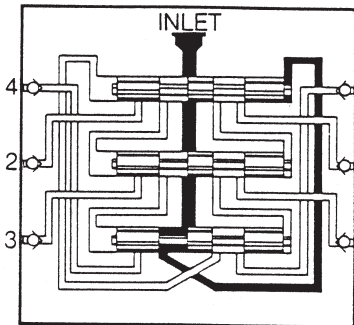

FIGURE 1

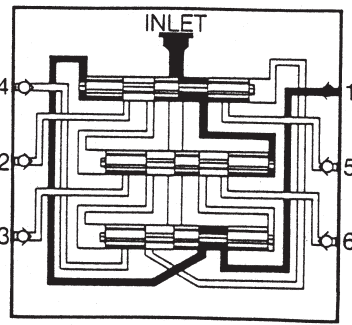

FIGURE 2

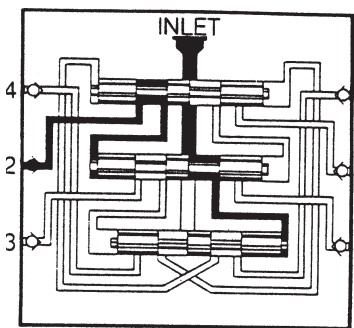

FIGURE 3

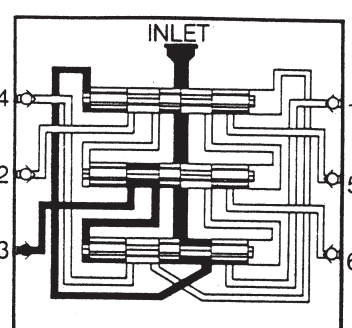

FIGURE 4

**FIGURE 1:** The inlet is connected to all piston chambers with only one piston free to move at any one time. With all pistons at the far right, lubricant flows against the right end of piston 1.

**FIGURE 2:** Lubricant flow moves piston 1 from right to left, displacing lubricant through passages to outlet 1. The shifting of piston 1 moves the lubricant flow against the right side of piston 2.

**FIGURE 3:** Lubricant flow moves piston 2 from right to left, displacing lubricant through outlet 2. The shifting of piston 2 moves the lubricant flow against right side of piston 3.

**FIGURE 4:** Lubricant flow shifts piston 3 from right to left displacing lubricant through outlet 3. The shifting of piston 3 moves the lubricant flow against right side of piston 1 (This would continue for as many valves mounted: 3-10 section).

Lubricant flow on left side of piston 1 begins the second cycle which shifts pistons from left to right, displacing lubricant through outlets 4, 5 and 6 of the valve.

# M2500G Series

## Description

The M2500G Series valve manifolds are the principal components of a Single Line central lubricating system. The modular construction makes the system easy to install, and can be modified and maintained without removing any tubing. Operation of all valves in the system can be monitored by a single cycle indicator switch. Up to 20 bearings can be lubricated from one manifold assembly and up to 20 manifolds can be included in a system.

Zone control components can be used to build a system of any size and can be divided into individually controlled and monitored zones. This permits varied cycle times, rapid trouble-shooting and easy maintenance.

## Features that Make the Difference

- VITON O-rings standard to protect against high heat & synthetic lubricants.
- Form, fit and functional interchangeable with all major competitive brands.
- SAE straight thread, NPSF or BSPP - all standard.
- Integral or in-line solenoid valve for zone control.
- Easy to assemble and replace valves without removing tube.
- Operating pressures to 5,800 psi.
- 0.005 to 0.080 cubic inch discharge volumes.
- Zinc-Nickel plating- 1000 hour salt spray.
- Three to Ten section valve manifolds available.

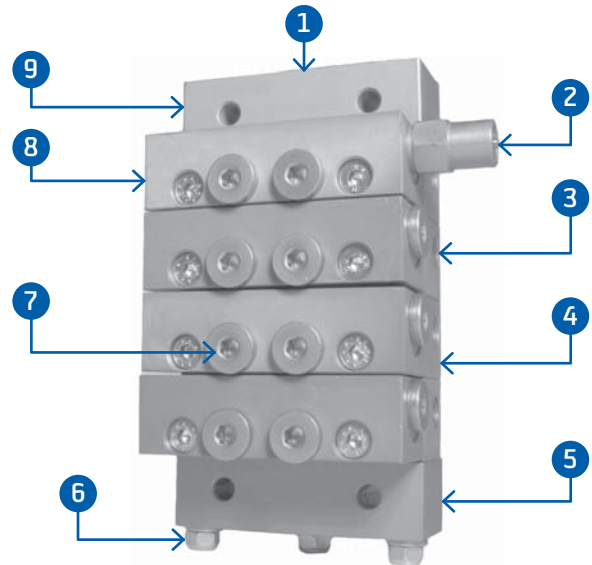

M2500B4G - 4 Section Valve Assembly

Item #	Description
1	Lube Inlet Port
2	Cycle Indicator Pin
3	Discharge Ports
4	Base Section
5	End Section

Item #	Description
6	Tie Rods
7	Alternate Outlet Port
8	Valve Section
9	Inlet Section

## M2500G Specifications

Max Operating Pressure	5800 psi (400 bar)
Min Operating Pressure	300 psi (20 bar)
Discharge Per Cycle	0.005 (0.08cc) to 0.080 (1.31cc)
Lubricant	Oil to NLGI #2 Grease
Seals	VITON O-rings (70 durometer)
Max. Temperature	350°F (163°C)
Material	Zinc-Nickel Plated

## Torque Specifications

Tie Rod Nuts	5-8 foot pounds
Outlet Port Fitting	8-9 foot pounds
Piston Enclosure Plugs	12-15 foot pounds
Valve Mounting Screws	8-9 foot pounds

## Divider Valve Assembly (Weight)

Divider Valve Assembly	Approximate Net Weight
3 Section Divider	6.2 lb (2.8 kg)
4 Section Divider	7.6 lb (3.5 kg)
5 Section Divider	9.1 lb (4.1 kg)
6 Section Divider	10.5 lb (4.8 kg)
7 Section Divider	11.9 lb (5.4 kg)
8 Section Divider	13.4 lb (6.1 kg)
9 Section Divider	14.8 lb (6.7 kg)
10 Section Divider	16.2 lb (7.4 kg)

# M2500G Series

M2500G Divider Valve Assemblies Consist of An Inlet Section, Base Sections (3-10), End Section and Valves

Valve Size	Discharge Cu. In. (cc)		Valve Sections			
	Twin Outlet	Single Outlet	Twin Outlet		Single Outlet	
			Standard	W/ Cycle Pin	Standard	W/ Cycle Pin
5	0.005 (0.08)	0.010 (0.16)	MCVA250105TG	--	MCVA250105SG	--
10	0.010 (0.16)	0.020 (0.33)	MCVA250110TG	--	MCVA250110SG	--
15	0.015 (0.25)	0.030 (0.49)	MCVA250115TG	--	MCVA250115SG	--
20	0.020 (0.33)	0.040 (0.66)	MCVA250120TG	MCVA250120TPG	MCVA250120SG	MCVA250120SPG
25	0.025 (0.41)	0.050 (0.82)	MCVA250125TG	MCVA250125TPG	MCVA250125SG	MCVA250125SPG
30	0.030 (0.49)	0.060 (0.98)	MCVA250130TG	MCVA250130TPG	MCVA250130SG	MCVA250130SPG
35	0.035 (0.57)	0.070 (1.15)	MCVA250135TG	MCVA250135TPG	MCVA250135SG	MCVA250135SPG
40	0.040 (0.66)	0.080 (1.31)	MCVA250140TG	MCVA250140TPG	MCVA250140SG	MCVA250140SPG

Note: Valve sections include VITON O-rings and mounting screws. MCVA2501BPG bypass valve with VITON O-rings is available.

## Divider Block Components

### Inlet Section

Inlet Type	Part #
Standard	#4 MCI2504AG
	1/4-18 NPSF MCI2504BG
	1/4-19 BSPP MCI2504CG
Zone-oil*	#4 37499A
	1/4-18 NPSF 37499B
	1/4-19 BSPP 37499C
Zone-grease*	#4 37500A
	1/4-18 NPSF 37500B
	1/4-19 BSPP 37500C

\*Note: Select Applicable Control Valve (MCZ2501 or MCZ2503) from page 12

### Valve Base Section

Description	Part #
#4 SAE discharge ports	MCBA2502AG
1/8-27 NPSF discharge ports	MCBA2502BG
1/8-28 BSPP discharge ports	MCBA2502CG

Note: Includes integral check valves, VITON O-rings

### End Section

Description	Part #
Includes VITON O-rings	MCEA2503G
Includes 1/8" NPT port for grease fitting	37484

## Dimensional Schematics

# of Sections	A	B
3	3.58" (91mm)	4.52" (115mm)
4	4.50" (114mm)	5.44" (138mm)
5	5.42" (138mm)	6.36" (162mm)
6	6.34" (161mm)	7.28" (185mm)
7	7.27" (185mm)	8.20" (208mm)
8	8.19" (208mm)	9.13" (232mm)
9	9.11" (231mm)	10.04" (255mm)
10	10.03" (235mm)	10.97" (279mm)

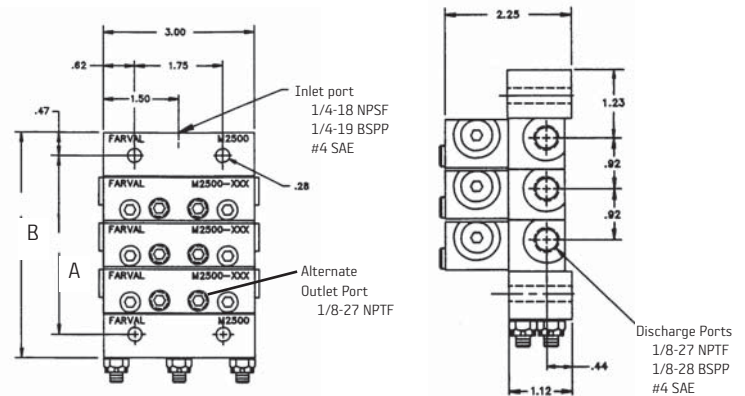

## Tie Rod Kits

Tie Rod Kits include 3 tie rods & 3 nuts.

# of Sections	Part #	# of Sections	Part #
3	MCRK25053G	7	MCRK25057G
4	MCRK25054G	8	MCRK25058G
5	MCRK25055G	9	MCRK25059G
6	MCRK25056G	10	MCRK250510G

# 1000 Series

## Description

The Series 1000 Progressive Divider Valve Manifold distributes and proportions incoming oil or grease to bearing points. A typical divider valve manifold consists of an inlet section, three to nine valves and an end section. One assembly can serve up to a maximum of 18 lubrication points.

Individual divider valve blocks have a discharge piston and built-in outlet check valves. Blocks are offered in three output sizes. The discharge capacity of a block is determined by varying the piston diameter in the valve block.

Twin valve blocks have two outlets located at each end of the assembly and supply rated discharge from each of the two outlets during one complete valve cycle. Single outlet blocks have one end outlet plugged and supply twice the rated output to the open outlet.

External crossporting of adjacent valves can be achieved with a crossporting kit to combine outputs.

## Progressive Divider Valve Operating Sequence

Individual valve blocks operate in a “progressive” sequence. During operation, the piston within the block must complete a full discharge cycle before another piston begins operation. As long as lubricant is supplied under pressure to the inlet section of the divider, manifold valve blocks will continue to operate in a progressive manner.

When lubricant flow is interrupted to the inlet block, piston movement stops. When flow resumes, piston movement commences at the same point in the discharge cycle. Feed lines deliver lubricant from the valve block to individual lube points. Should a discharge line become blocked, it will stop all the valves operating.

Indicators are available to alert a blockage.

## 1000 Series Specifications

Max Operating Pressure	2000 psi (138 bar)
Min Operating Pressure	300 psi (20 bar)
Discharge Per Cycle	0.005 (0.082cc) - 0.030 (0.492cc)
Lubricant	Oil to NLGI #2 Grease
Seals	Non-asbestos composition with steel core
Max. Temperature	350°F (163°C)
Material	Steel (Zinc Plated)

## Torque Specifications

Tie Rod Nuts	60-70 inch pounds
Outlet Port Fitting	72-89 inch pounds
Piston Enclosure Plugs	15 foot pounds

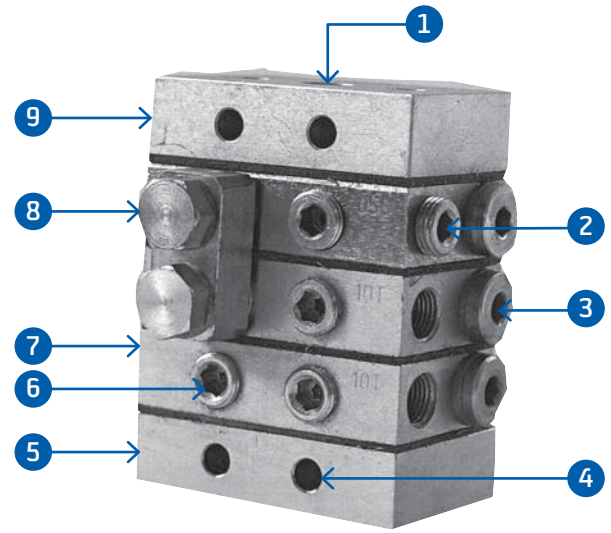

Item #	Description
1	1/8" NPT or 1/8" BSP Lube Inlet
2	1/8" NPT or 1/8" BSP Lube Outlet
3	Piston Enclosure Plugs
4	0.190 Mounting Holes (4)

Item #	Description
5	End Section
6	1/8" NPT or 1/8" BSP Alternate Outlet Ports
7	Valve Sections
8	Cross Port Kit
9	Inlet Section

## Divider Valve Assembly (Weight)

Divider Valve Assembly	Approximate Net Weight
3 Section Divider	1.9 lb (0.88 kg)
4 Section Divider	2.3 lb (1.04 kg)
5 Section Divider	2.7 lb (1.21 kg)
6 Section Divider	3 lb (1.38 kg)
7 Section Divider	3.4 lb (1.55 kg)
8 Section Divider	3.8 lb (1.72 kg)
9 Section Divider	4.2 lb (1.89 kg)

Refer to the following documents for more info:

+ Datasheet #27663: 1000 Divider Valves

# 1000 Series

1000 Series Divider Valve Assemblies consist of an Inlet Section, Several Valve Sections (3-9) and an End Section.

Valve Size	Discharge Cu. In. (cc)		Valve Sections					
	Twin Outlet	Single Outlet	Twin Outlet			Single Outlet		
			Standard	W/ Cycle Pin	W/ Cycle Pin SW	Standard	W/ Cycle Pin	W/ Cycle Pin SW
05	.005 (.082)	.010 (.164)	1000-05AT	N/A	N/A	1000-05AS	N/A	N/A
10	.010 (.164)	.020 (.328)	1000-10AT	N/A	N/A	1000-10AS	N/A	N/A
15	.015 (.246)	.030 (.492)	1000-15AT	1000-157LT	1000-158LT	1000-15AS	1000-157LS	1000-158LS

Note<sup>1</sup>: Above are supplied with 1/8" NPT threads, if 1/8" BSP threads are required add BSP after above part numbers. Example: 1000-05ATBSP

Note<sup>2</sup>: Above cycle pin and cycle switch numbers are for left side mounted pin/switch, if right side mounted pin or switch is required substitute R for L in part #.

Example: 1000-157RT.

## Divider Block Components

Description	Part #
Inlet Section 1/8" NPT	1006-1
Inlet Section 1/8" BSP	1006-1BSP
End Block	1007-1
Gaskets (order separately)	1009

## Tie Rod Kits

Description	Part #	
Tie Rod Kit	3 Valves	1017-3K
	4 Valves	1017-4K
	5 Valves	1017-5K
	6 Valves	1017-6K
	7 Valves	1017-7K
	8 Valves	1017-8K
	9 Valves	1017-9K

Note: Kits include 2 tie rods and 2 nuts.

## Dimensional Schematics

# of Valve Blocks	A	B
3	2.34" (59.4mm)	2.87" (73.1mm)
4	2.92" (74.2mm)	3.46" (87.9mm)
5	3.50" (89.0mm)	4.04" (102.6mm)
6	4.08" (103.7mm)	4.62" (117.4mm)
7	4.66" (118.5mm)	5.2" (132.2mm)
8	5.25" (133.3mm)	5.78" (147mm)
9	5.83" (148.1mm)	6.37" (161.8mm)

## Valve Manifold Assemblies

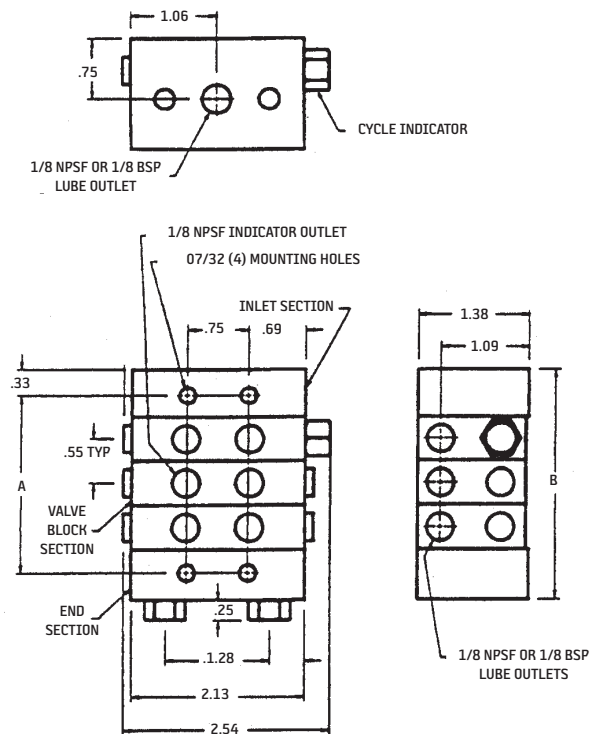

Dimensions in inches

# 3000 Series

## Description

The Series 3000 Progressive Divider Valve manifold distributes and proportions incoming oil or grease to bearing points. A typical divider valve manifold consists of an inlet section, three to ten valves and an end section. One assembly can serve up to a maximum of 20 lubrication points.

Individual divider valve blocks have a discharge piston and built-in outlet check valves. Blocks are offered in six output sizes. The discharge capacity of a block is determined by varying the piston diameter in the valve block.

Twin valve blocks have two outlets located at each end of the assembly and supply rated discharge from each of the two outlets during one complete valve cycle. Single outlet blocks have one end outlet plugged and supply twice the rated output to the open outlet. External crossporting of adjacent valves can be achieved with a crossporting kit to combine outputs.

## Progressive Divider Valve Operating Sequence

Individual valve blocks operate in a “progressive” sequence. During operation, the piston must complete a full discharge cycle before another piston begins operation. As long as lubricant is supplied under pressure to the inlet section of the divider, valve blocks will continue to operate in a progressive manner.

When lubricant flow is interrupted to the inlet block, piston movement stops. When flow resumes, piston movement commences at the same point in the discharge cycle. Feed lines deliver lubricant from the valve block to individual lube points. Should a discharge line become blocked, it will stop all the valves operating.

Indicators are available to alert a blockage.

## 3000 Series Specifications

<b>Max. Operating Pressure</b>	3000 psi (207 BAR)
<b>Min. Operating Pressure</b>	300 psi (20 BAR)
<b>Discharge Per Cycle</b>	0.025 (.41cc) - 0.300 (4.92cc)
<b>Lubricants</b>	Oil to NLGI #2 grease
<b>Seals</b>	Plated steel with bounded Viton® seals
<b>Max. Temperature</b>	350°F (163°C)
<b>Material</b>	Steel (zinc plated)

## Torque Specifications

<b>Tie Rod Nuts</b>	72-78 inch pounds
<b>Outlet Port Fitting</b>	72-96 inch pounds
<b>Piston Enclosure Plugs</b>	48 foot pounds

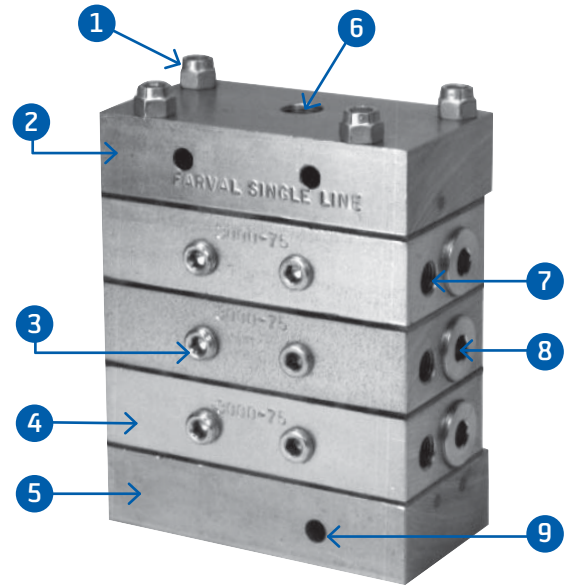

Item	Description
1	Tie Rods
2	Inlet Section
3	1/4 NPT Alternate Outlet Ports
4	Valve Sections
5	End Section

Item	Description
6	3/8 NPT Lube Inlet
7	1/4 NPT Lube Outlet
8	Piston Enclosure Plugs
9	0.344 MTG Holes

## Divider Valve Assembly (Weight)

Divider Valve Assembly	Approximate Net Weight	
3 section divider	22 lbs	9.98 kg
4 section divider	27 lbs	12.24 kg
5 section divider	32 lbs	14.52 kg
6 section divider	37 lbs	16.78 kg
7 section divider	42 lbs	19.05 kg
8 section divider	47 lbs	21.32 kg
9 section divider	52 lbs	23.57 kg
10 section divider	57 lbs	25.86 kg



# 3000 Series

3000 Divider Valve Assemblies consist of an Inlet Section, Several Valve Sections (3-10) and an End Section.

Valve Size	Discharge cu. in. (cc)		Valve Section					
	Twin Outlet	Single Outlet	Twin Outlet			Single Outlet		
			Standard	W/ Cycle Pin	W/ Cycle SW	Standard	W/ Cycle Pin	W/ Cycle SW
25	.025 (.41)	.050 (.82)	300025	N/A	N/A	300025X	N/A	N/A
50	.050 (.82)	.100 (1.64)	300050	3000507	3000508	300050X	3000507X	3000508X
75	.075 (1.23)	.150 (2.46)	300075	3000757	3000758	300075X	3000757X	3000758X
100	.100 (1.64)	.200 (3.28)	3000100	30001007	30001008	3000100X	30001007X	30001008X
125	.125 (2.05)	.250 (4.10)	3000125	30001257	30001258	3000125X	30001257X	30001258X
150	.150 (2.46)	.300 (4.92)	3000150	30001507	30001508	3000150X	30001507X	30001508X

## Tie Rod Kits

Description		Part #
Tie Rod Kit	3 Valves	FT25171A
	4 Valves	FT25171B
	5 Valves	FT25171C
	6 Valves	FT25171D
	7 Valves	FT25171E
	8 Valves	FT25171F
	9 Valves	FT25171G
	10 Valves	FT25171H

Note: Sold individually each assembly requires 4 tie rods

## Dimensional Schematics

# of Valves	A	B
3	5-7/16	6-9/16
4	6-3/4	7-7/8
5	8-1/16	9-3/16
6	9-7/16	10-9/16
7	10-3/4	11-7/8
8	12-1/16	13-3/16
9	13-3/8	14-1/2
10	14-11/16	15-13/16

## Inlet Section (Part #3006) & End Section (Part #3007)

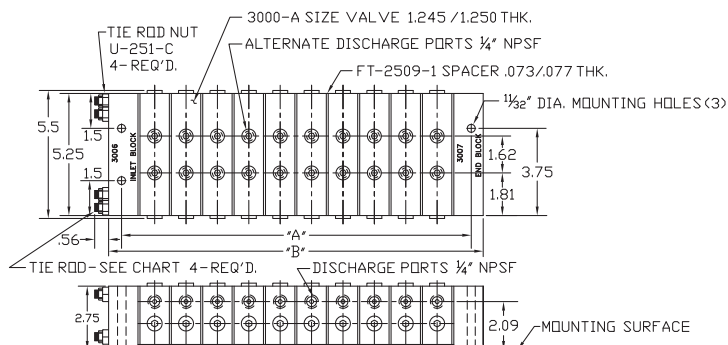

## Inlet (3006) and End (3007) Block Dimensions

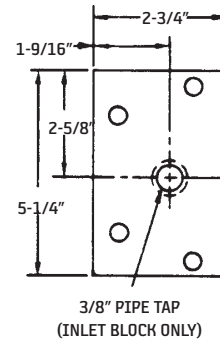

## Gasket (Part #FT25091) Dimensions Order Separately

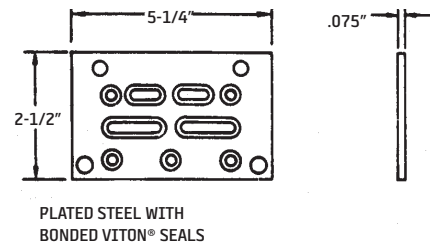

## Manifold Tie Rod (Part #FT2517)

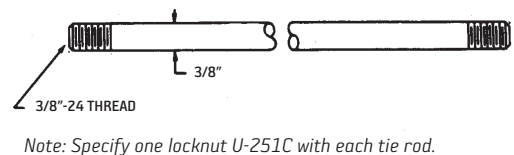

# FD Series

## Description

FD Series Valves are designed for use with series progressive oil and grease lubrication systems. The FD Divider Valve distributes and proportions incoming oil or grease to bearing points.

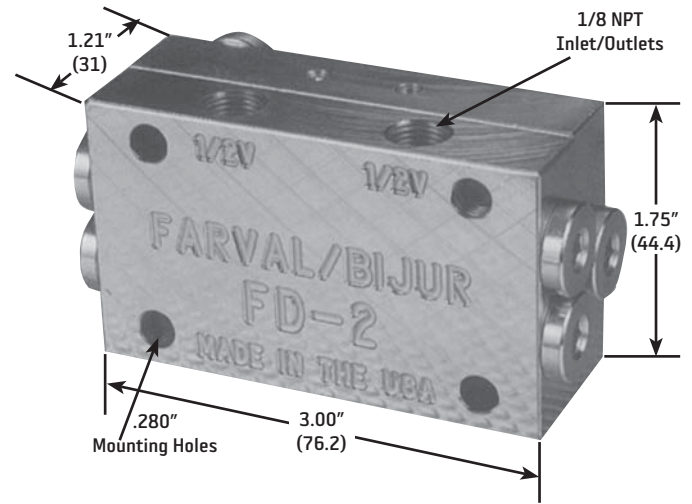
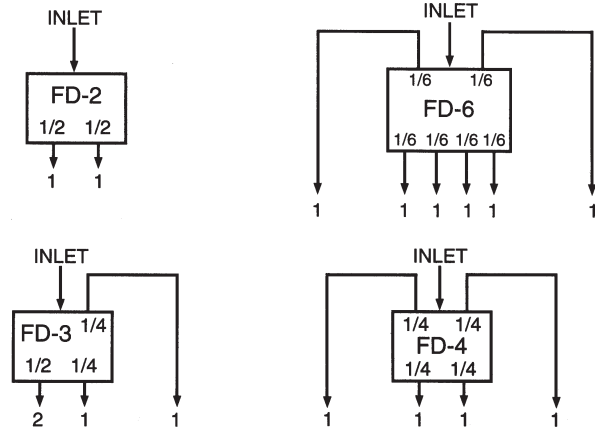

## FD Series Specifications

<b>Max. Operating Pressure</b>	3000 psi (207 bar)	
<b>Lubricant</b>	Oil to NLGI #2 grease	
<b>Seals</b>	Viton O-Rings	
<b>Volume</b> (Lubricant required to cycle divider valve once)	FD-2, FD-3 & FD-4	0.080 in. <sup>3</sup> (1.31 ccm)
	FD-6	0.060 in. <sup>3</sup> (0.98 ccm)
<b>Material</b>	Steel (zinc plated)	
<b>Max. Temperature</b>	350°F (163°C)	
<b>Net Weight</b>	1.5 lb (0.68 kg)	

## How to Order

# of Lube Outlets	Standard Model	W/Cycle Indicator Pin (Right Side)
2	FD-2	FDP-2
3	FD-3	FDP-3
4	FD-4	FDP-4
6	FD-6	---

## Accessories

Description	Part #
Cycle Switch	17324
Bracket Assembly	33583

Note: To use High Pressure indicators with FD Divider Valves, a tee (Part No.'s U101A1 Nipple and U137A Tee) is required for each outlet. (See page 10 for indicators)

Refer to the following documents for more info:

+ Datasheet #32573: FD Series Divider

# SureShot Kit

## Divider Block for Manual Lubrication of Multiple Points

For machinery applications with multiple lubrication points, you sometimes need a method to grease them from a centralized location with a manual grease gun.

The SureShot system delivers a positive measured shot of grease to each connected lubrication point through a single manually-fed grease fitting. Just mount the block in a convenient location and route the pre-filled tubing to each lubrication point. Then, walk up to the block and grease your entire machinery!

### Included in a SureShot kit:

- Divider block (4, 6, 8, 10 or 12 outlets)
- Pre-filled tubing
- Hardware for installation (elbow, straight, 45- and 90-degree adapters)

Pre-Filled Tubing	Description	Part #
25'	For 3 or 4 lubrication points	SST4C
50'	For 5 or 6 lubrication points	SST6C
75'	For 7 or 8 lubrication points	SST8C
75'	For 9 or 10 lubrication points	SST10C
100'	For 11 or 12 lubrication points	SST12C

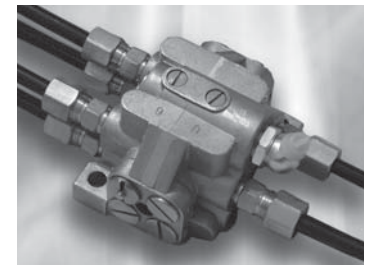

# Ordering Instructions

Completely assembled Single Line M2500G Modular Valve Manifolds can be ordered as follows:

First, select the manifold base assembly from the table. This assembly includes the inlet section, valve base sections, end section, tie rods, nuts and o-rings; the valve sections are installed on it. Each valve section and bypass section requires a base section, and every manifold must have at least 3 operating valve sections.

Next, specify the valves, bypass sections and accessories. Begin at the first section after the inlet and continue towards the end section. Separate each entry with a slash:

1 2 3 4  
/ - - - , - - - , - - -

## 1 - Valve/Size (05, 10, 15, etc.)

- T - Twin
- S - Single (no outlet)
- SL - Single (outlet to left)
- SR - Single (outlet to right)

## 2 - Outlets

## 3 - Optional Accessories

- PP - Pin-type pressure indicator\*
- CIP - Cycle indicator PIN
- CS - Cycle switch\*\*
- CP - Crossport

Note: \*\*Specify which cycle switch model (See page 13)

Note: \*Provide part number (See page 10)

Add L or R to the above codes to specify the location of each accessory

## 4 - Other Accessories (as required)

Note: Zone control valves are ordered as separate items as shown on pages 11 and 12. Omit the mounting style code. Other accessories such as electrical cables must also be ordered as separate items.

Inlet Type	# of Sections	Discharge Ports			
		#4SAE	1/8-27 NPSF	1/8-28 BSPP	
Standard	3	M2500A3G	M2500B3G	M2500C3G	
	4	M2500A4G	M2500B4G	M2500C4G	
	5	M2500A5G	M2500B5G	M2500C5G	
	6	M2500A6G	M2500B6G	M2500C6G	
	7	M2500A7G	M2500B7G	M2500C7G	
	8	M2500A8G	M2500B8G	M2500C8G	
	9	M2500A9G	M2500B9G	M2500C9G	
	10	M2500A10G	M2500B10G	M2500C10G	
	Zone-Oil MCZ2501 Series	3	M2500A3ZG	M2500B3ZG	M2500C3ZG
		4	M2500A4ZG	M2500B4ZG	M2500C4ZG
5		M2500A5ZG	M2500B5ZG	M2500C5ZG	
6		M2500A6ZG	M2500B6ZG	M2500C6ZG	
7		M2500A7ZG	M2500B7ZG	M2500C7ZG	
8		M2500A8ZG	M2500B8ZG	M2500C8ZG	
9		M2500A9ZG	M2500B9ZG	M2500C9ZG	
10		M2500A10ZG	M2500B10ZG	M2500C10ZG	
Zone-Grease MCZ2503 Series		3	M2500A3XG	M2500B3XG	M2500C3XG
		4	M2500A4XG	M2500B4XG	M2500C4XG
	5	M2500A5XG	M2500B5XG	M2500C5XG	
	6	M2500A6XG	M2500B6XG	M2500C6XG	
	7	M2500A7XG	M2500B7XG	M2500C7XG	
	8	M2500A8XG	M2500B8XG	M2500C8XG	
	9	M2500A9XG	M2500B9XG	M2500C9XG	
	10	M2500A10XG	M2500B10XG	M2500C10XG	

**EXAMPLE:** Ordering code for complete assembly. The complete part number for an M2500G manifold with the following specifications would be: **M2500B5G/05SR/10S,CPR/10SL/BP/30T**

5 section manifold, NPSF ports, standard inlet	M2500B5G
05 single, outlet right, visual indicator to left	05SR
10 single, no outlet, crossport to right	10S, CPR
10 single, outlet left	10SL
Bypass section	BP
30 twin, outlets left and right	30T

Note: For 1000/3000 series, replace M2500BG in the above example with 1001/3001. Must have minimum of 3 working sections.

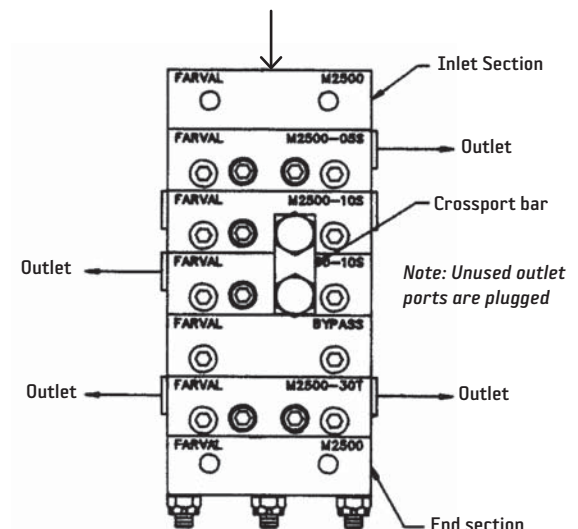

Provide basic sketch similar to above when ordering

# Singline Accessories

## Crossport Kit

Crossport kit is installed in the alternate outlet port of adjacent valves to combine the outputs to feed a single lubrication point.

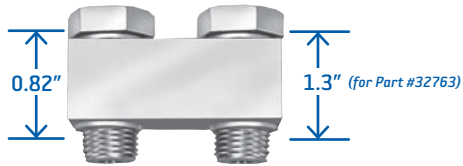

Description	Part #
1000 Series	32265-1 (BSP)
	32265-2 (NPT)
M2500G Series	37083G
3000 Series	32763

## High Pressure Indicators

These indicators are spring-loaded and can only be reset when system pressure decreases. The indicator's memory pin remains extended until manually reset. They are installed in the alternate outlet port.

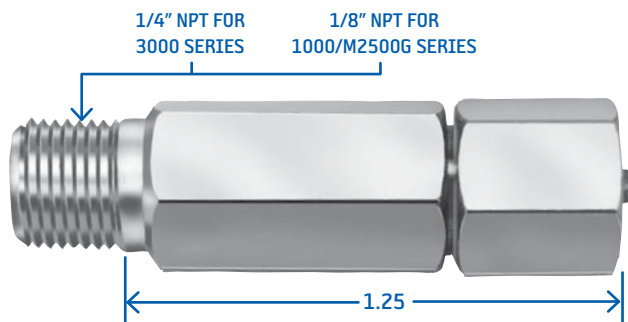

Description	Pressure Rating	Part #
Non-Relieving Type for 1000/M2500G Series	600 psi	20356
	1200 psi	203512
	1600 psi	203516
	2200 psi	203522
Relieving Type for 1000/M2500G Series <sup>1</sup>	1000 psi	213510
	1500 psi	213515
	2000 psi	213520
Non-Relieving Type for 3000 Series	600 psi	FT25353G
	1000 psi	FT25353Y
	2000 psi	FT25353R

*Note<sup>1</sup>: These have small weep hole to relieve pressure.*

## Rupture Disc Indicators

These indicators burst at a selected pressure to automatically relieve excessive system pressure. They are installed in an alternate outlet port. All indicators are assembled with one rupture disc.

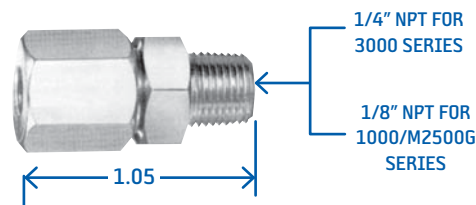

Description	Burst Pressure	Disc Color	Replacement Disc Kit*	Part #
For 1000/M2500G Series	1450 psi	Yellow	FT15423YWK	104127W
	1750 psi	Red	FT15423RDK	10412RD
	3250 psi	Purple	FT15423PRK	10412PR
For 3000 Series	900 psi	Black	FT15423BKK	FT25413B
	1450 psi	Yellow	FT15423YWK	FT25413Y
	1900 psi	Red	FT15423RDK	FT25413RD

*Note\*: Discs are sold in packs of 10 pieces*

# Singline Accessories

## Zone Control Valves

Zone Control Valves are typically used to isolate certain sections on a machine to receive more/less frequent lube cycles.

### Style

- MCZ2501F series for oil systems operating up to 1500 psi
- MCZ2501A series for oil systems operating between 1500 and 3000 psi
- MCZ2503B series for all grease systems operating up to 3000 psi

### Installation

- In the inlet section of M2500G series manifold (see page 4 for zone inlets)
- As a stand alone component mounted in a remote location

### Electrical

- 115 Volt AC (50 or 60 Hz)
- 24 Volt DC
- Class H Coils

### Connectors

- Standard 1/2 inch conduit with insulated 18 AWG leads
- Automotive 3 pin connector accepts Brad harrison Mini-Change or Crouse Hinds Mini-Line connectors. Conforms to ANSI B93.55M
- Hirschmann connector

### Port Types

- Integral valves: #4 SAE, 1/4-18 NPSF or 1/4-19 BSPP on inlet
- Remote valves: #6 SAE or 1/4-18 NPTF on inlet and outlet

### Electrical Specifications

Amp Draw	MCZ2501F	MCZ2501A	MCZ2503B
115 AC	.21 amp	.21 amp	.17 amp
24V DC	.90 amp	.90 amp	.83 amp

### M2500G Valve Manifolds with Integral Zone Control

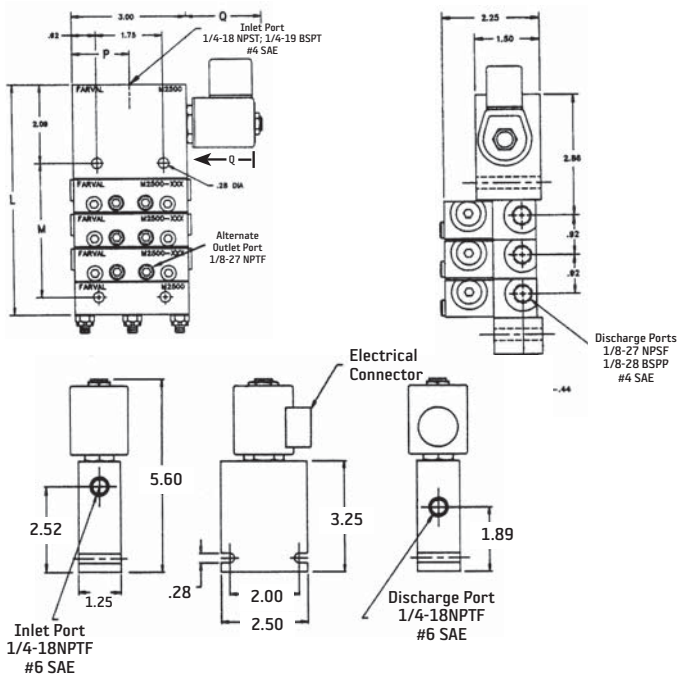

Grease Service (MCZ2503 Series)

### M2500G Integral Oil or Grease

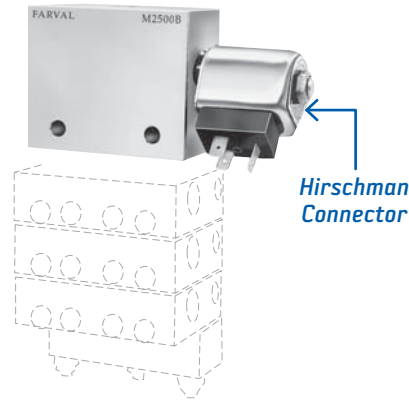

### Remote-Grease MCZ2503B



### Remote-Oil



Lubricant	P	Q
Oil Service (MCZ2501 Series)	1.50	1.82
Grease Service (MCZ2503 Series)	2.25	2.35

### Dimensions

# of Sections	M		L	
	Inch	MM	Inch	MM
3	3.58	91	7.03	179
4	4.50	114	7.95	202
5	5.42	138	8.97	228
6	6.34	161	9.80	249
7	7.27	185	10.72	272
8	8.19	208	11.64	296
9	9.11	231	12.56	319
10	10.03	255	13.48	342

### Remote Zone Control Valves

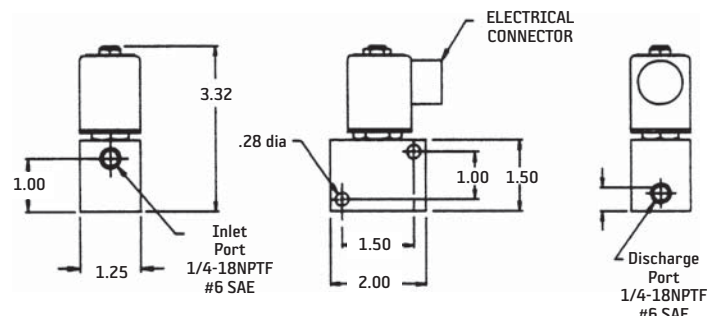

Oil Service (MCZ2501 Series)

# Singline Accessories

## Zone Control Valve Selection Chart

			1	2	3	4
Oil Systems	Below 1500 psi (103 bar)	MCZ2501F	*	*	*	*
	Above 1500 psi (103 bar)	MCZ2501A	*	*	*	*
Grease Systems		MCZ2503B	*	*	*	*

Note: All Zone Control Valves are sent standard as normally closed. Contact factory if normally open is required.

### Codes\*

1. Seal Material	2. Electrical Connector	3. Voltage	4. Mounting and Port Style <sup>1</sup>
00 – Nitrile	DL – Conduit	11 – 115 VAC 50/60 hz	N – 1/4-18 NPTF inlet and discharge
VO – Viton	HC – Hirschmann	24 – 24 VDC	S – #6 SAE (3/8 OD tube) inlet and discharge
---	BH – Automotive	---	---

Note<sup>1</sup>: Use this code for remote valves only, not for integral valves.

### Examples

- For an integral zone control in a 400 psi oil system, nitrile seals, an automotive connector, operating on 120 volt 60hz current, and with SAE ports, order **MCZ2501F00BH11** cartridge and **37499A** zone inlet oil (see page 4).
- For a remote zone control in a grease system, nitrile seals, a Hirschmann connector, 24 volt DC current, and with NPTF ports, order **MCZ2503B00HC24N**.

## Electrical Accessories for Zone Control Valves and Cycle Switches

### Crouse Hinds/Brad Harrison Automotive-Type Electrical Connectors with Molded Cable

These feature molded 3 pin automotive connectors and are used with cycle switches and type BH Zone Control Valves. The 3-conductor cables are yellow PVC insulated STO rated at 10 amps and 300 volts.

Description	Part #
6 feet, NEMA 6P, IP68 protection	MCC2505A
12 feet, NEMA 6P, IP68 protection	MCC2505B

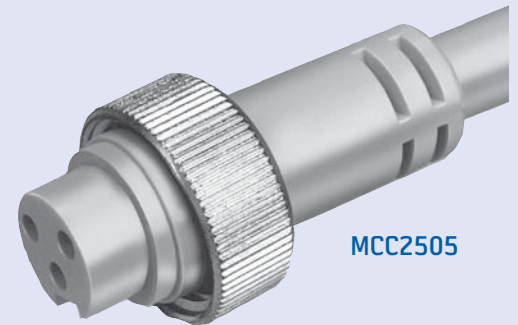

### M12 4-Pole Electrical Connectors with Cable

These connectors, made to M12 specifications, are used with the AC498-1 Switches and 55105 Lube Point Monitors.

Description	Part #
Straight, 10 meters long	76928-2863
90°, 10 meters long	76928-2833



### Hirschman-Type Electrical Connectors

These connectors, made to DIN 43650 specifications, are used with type HC zone control valves. They include all hardware including gaskets. They are rated at 250 VAC and 16 amperes.

Description	Part #
For MCZ2501 Series Zone Control Valves. DIN 43650 Form B 11mm blades. 1.12" by 0.82"	MCC2509A
For MCZ2503 Series Zone Control Valves. DIN 43650 Form A. 1.08" square	MCC2510A



# Singline Accessories

## Cycle Indicators/Cycle Switches

Manifold cycle indicators provide a means of monitoring lube flow thru the system - a pin cycles in and out when lubricant is flowing. Movement of the pin is caused by the piston (the two are pinned together) so that when the piston, and thus the entire manifold, cycles once, the pin moves in and out once. The switches can be wired to warn of system trouble. They can feed electric pulses to a control device such as SS2200 or SC400 controller or customer PLC.

## Electrical Cycle Switches

### M2500G Series

#### Mechanical Cycle Switches

**17324 Cycle Switch w/1/2-14 NPSM conduit connector**

**33583 Bracket (Required with switch)**

**(Order both parts separate)**

Couples to any M2500G metering valve having a cycle indicator pin and provides an electrical signal each time the divider valve operates. SPDT switch is rated 15 amps @ 125/250 VAC, 0.5 amps @ 125 VDC.

#### AC498-1 with 4 Pin Micro Connector M12 x 1 & LED Light

Couples to any M2500G metering valve. Rated to 5000 psi (350 bar). Requires 10-36 VDC. To be used with the SC400 Controller or customer PLC only (refer to page 12 for cables).

#### MCSA2503 with Automotive Type 3 Pin Connector

Because they use a magnet to sense piston position, entry of contaminants into the system is prevented. These cycle switches may be installed in the end of M2500G valve size 15' and larger. The SPDT switch is rated at 250 VAC/28 VDC-5 Amps.

### 1000 Series

#### Electrical Cycle Switches

(Sold only attached to 15 single or 15 twin Divider Valve Sections.

See chart top of page 5). Provides an electrical signal each time the divider valve operates. SPDT switch is rated 15 amps @ 125/250 VAC, .5 amps @ 125 VDC.

### 3000 Series

#### Electrical Cycle Switches

**FT15801C8 with 1/2-14 NPSM Conduit Connector**

Couples to any 3000 metering valve having a cycle indicator pin and provides an electrical signal each time the divider valve operates. SPDT switch is rated 15 amps @ 125/250 VAC, 0.5 amps @ 125 VDC.

### 37786

#### Visual Cycle Indicator

Visual cycle indicator for monitoring. Reflective orange indicator is visible for over 30 feet. Couples to any M2500G metering valve. Pin reduces output of valve by 0.0038cu.(0.06cc)

17324 & 33583

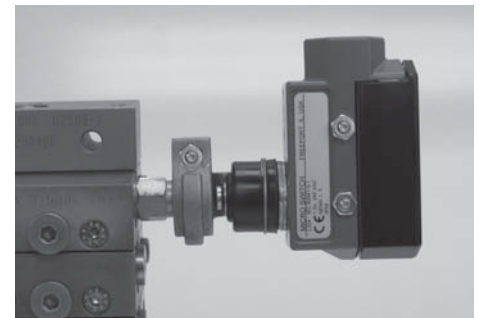

AC498-1

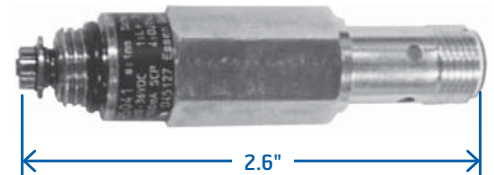

MCSA2503



37786

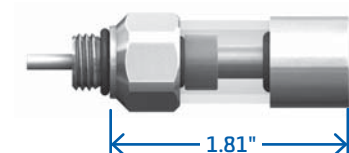

# Miscellaneous Pumps

Mechanical pumps are driven through a connecting rod or cam by the machine being lubricated. A small quantity of lubricant (it can be either grease or oil) is delivered during each cycle as long as the machine is operating. Lube source can be either a reservoir or header line with a shut off valve, filter or strainer and pressure regulator between the header line and pump. 10 psi pressure at the pump is required for positive priming.

## Ordering Information

The components - pumps, reservoir, and pressure regulator - must be ordered separately. They are not sold as complete stations.

*Warning: For safety of equipment and personnel, include one of the pressure indicators described. They provide relief for the system in case of line blockage.*

## Direct Drive Pumps - Model TP2

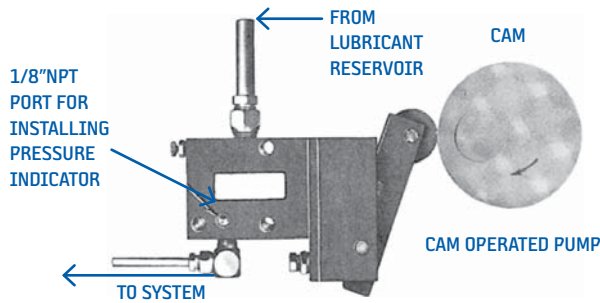

*Note: Cam operated pumps can also be mounted on a way or slide and operated by a trip cam.*

## Pump Specifications

Pump Part #	Discharge Cu. In.		Method of Pump Operation	Pump Return Action	Pressure Ratio at Suggested Minimum Operating Pressure	Maximum Operating Pressure	Maximum Cycles Per Min.			
	Minimum	Maximum					At Max. Disch. Adjustment		At 50% Max. Disch. Adjustment	
							NLGI #1	NLGI #2	NLGI #1	NLGI #2
TP2C2	0	.095 (1.6cc)	Cam	Spring	11 Times Operating Force	As required	60	30	75	37

## Manual Pumping Stations

For bearings that require an application of lubricant infrequently, the manually-operated pumping unit is used, and may be located on the machine or at any convenient point nearby.

These units consist of a double-acting piston pump, reciprocated by a hand lever through a rack-and-gear segment. A quick-fill connection provides a convenient means of filling the reservoir, and an inlet filter screen gives added protection against the entry of dirt.

Where oil is employed, a float with oil level rod replaces the grease follower plate. Three sizes of reservoirs provide a supply of lubricant adequate for the number of bearings being lubricated.

Discharge Per Cycle*	Lube Type	A (Max.)	Reservoir Capacity	Part #
0.45 cu. in. (7.44 cc)	Grease	24	4-1/2 lb	DA4120AC
		37	8-1/4 lb	DA5120AC
	Oil	22	2-1/2 qts	DA4120BC or DA4102BC
		49	6-1/2 qts	DA6102BC

*Note\*: This is the volume discharged by one in and out operation of the hand lever.*

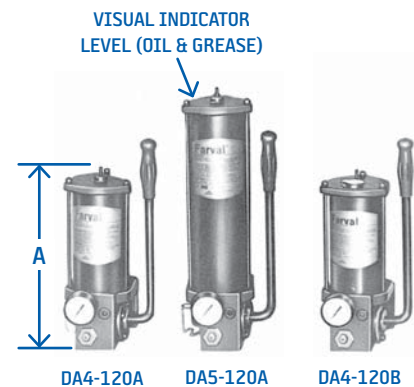

*Note: Series 120 pump is designed for single line lubricating systems and series 102 for jacking heavy loads.*

Refer to the following documents for more info:

+ Datasheet #35518: DA Lubricator



# TP11, 12, 13, 22, 23 Pumps

## Application

TP Pumps are used on central pumping stations with T30 or T32 reservoirs; or in bulk oil installations without reservoirs. They are actuated by air or hydraulic power.

## Description

The pumps meet a wide range of requirements as shown in the table below. The discharge capacities range from 0.015 to 0.170 cubic inches per stroke. These pumps offer a range of pressure ratios, and are available as single acting, spring return or double acting, power return.

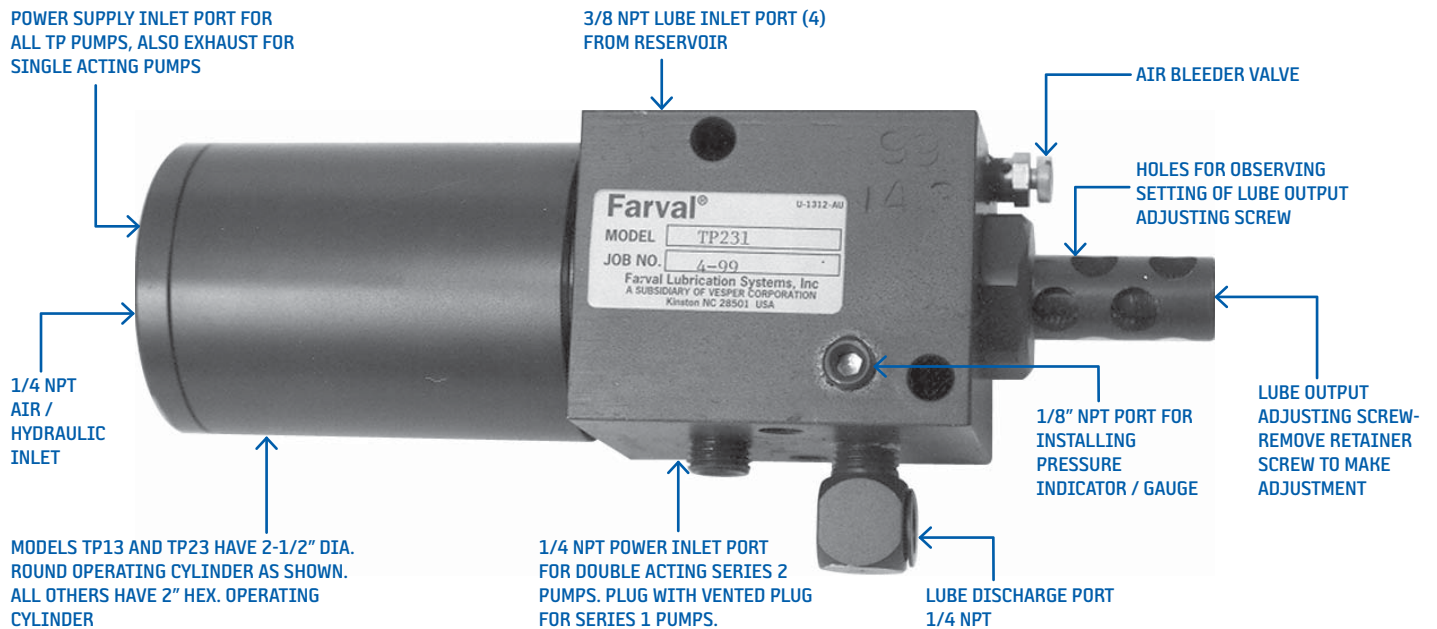

## Pump Specifications

Order Code LTR.	Pump Part #	Discharge Cu. In Per Stroke (C.C.)		Type <sup>1</sup>	Method of Pump Piston Return	Pump Pressure Ratio <sup>2</sup>	Air or Hydraulic Input Pressure <sup>3</sup>		Maximum Cycles Per Min.			
		Minimum	Maximum				Minimum	Maximum	At Max. Disch. Adjustment		At 50% Max. Disch. Adjustment	
									NLGI #1	NLGI #2	NLGI #1	NLGI #2
C	TP121C	.015 (.25)	.068 (1.1)	Air	Spring	18:1	60 psi	200 psi	40	20	50	25
E	TP131C	.015 (.25)	.068 (1.1)	Air	Spring	50:1	30 psi	50 psi				
J	TP222C	.035 (.57)	.170 (2.8)	Hydraulic	Hydraulic	7:1	200 psi	500 psi				
K	TP231C	.035 (.57)	.170 (2.8)	Air	Spring	18:1	60 psi	200 psi				

Note<sup>1</sup>: Listings in this column show our recommendations based on pump pressure ratios in relation to typical machine air and hydraulic power supply pressures.

Hydraulic pressure must fall below 2 psi during relief cycle when using pumps for single acting (spring return) hydraulic service.

Note<sup>2</sup>: Pressure ratios decrease at lower operating pressures - will increase slightly (up to 10%) at higher operating pressures.

Note<sup>3</sup>: When using pump input pressures that generate pump output pressures over 3000 psi use either rupture disc indicator (Part No. 1041-2YN) in the pump port or relief type pressure indicator U-1980-1 in pump outlet line to prevent hazardous over pressurizing of lube system.

Note<sup>4</sup>: Maximum lube inlet pressure is 15 psi.

Refer to the following documents for more info:

+ Datasheet #35609: TP Lubricator

# T30 and T32 Reservoirs

## Application

These reservoirs are used with the pumps described on page 15. When lubricating typical machine tools, they require 200 hours of system operation before refilling.

## Description

Typical oil and grease reservoirs are shown below and characteristics of the reservoirs are tabulated in the table. The low-level switch is single pole double throw with a UL rating of:

Model	Description
T30 and T32	10 amps at 125/250, or 3 amps at 480 volts A.C.
	0.5 amps at 125 volts D.C.
	0.25 amps at 250 volts D.C.



Grease Reservoir T30P5AC  
(Shown w/o pump attached)

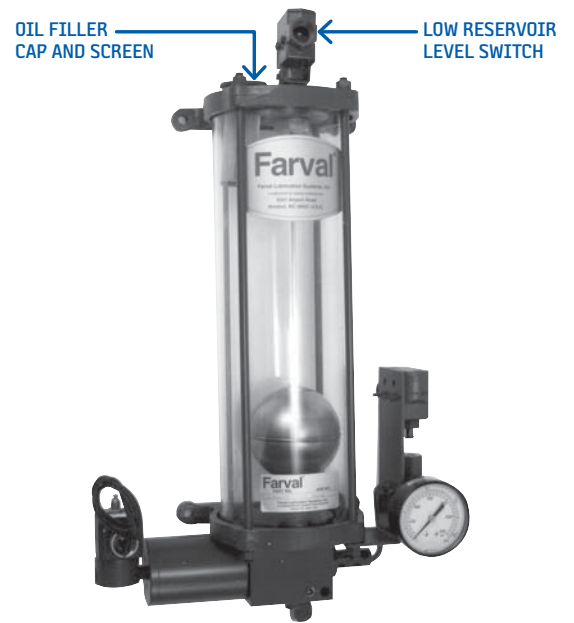

Oil Reservoir T30P5B  
(Shown w/pump attached)

## Models T30 and T32

Body Material	Reference Letter	Lubricant	Capacity	Lubricant Level Indication	Part #
Steel	B	Grease	5 pounds	Level Switch, Stem	T30S5AC
Plastic	F	Grease	5 pounds	Level Switch, Transparent	T30P5AC
	G	Oil	2.5 quarts	Transparent	T30P4BC
	H	Oil	2 quarts	Level Switch, Transparent	T30P5B
	R	Grease	10 pounds	Level Switch, Transparent	T32P5AC
	S	Oil	6 quarts	Transparent	T32P4BC
	T	Oil	5.5 quarts	Level Switch, Transparent	T32P5B

# TS30 Pumping Stations

## Application

These stations lubricate machines having pneumatic or hydraulic power. All models use TP pumps and supply grease or oil.

## Description

Complete pumping stations consist of various combinations of the reservoirs, pumps, etc., listed in the ordering code tables on this page.

## Dimensional Schematics

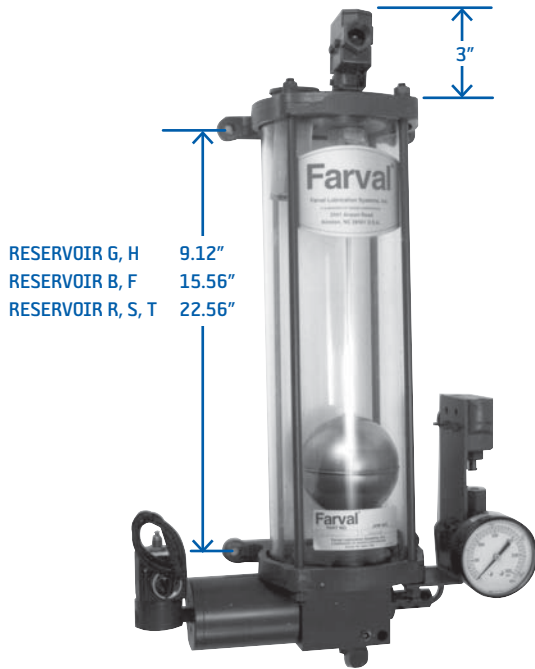

TS30-TKEXA Station with Pump,  
Reservoir and Accessories

## How to Order

Typical Ordering Code: TS30 Stations (Part #TS30-TKEXA)

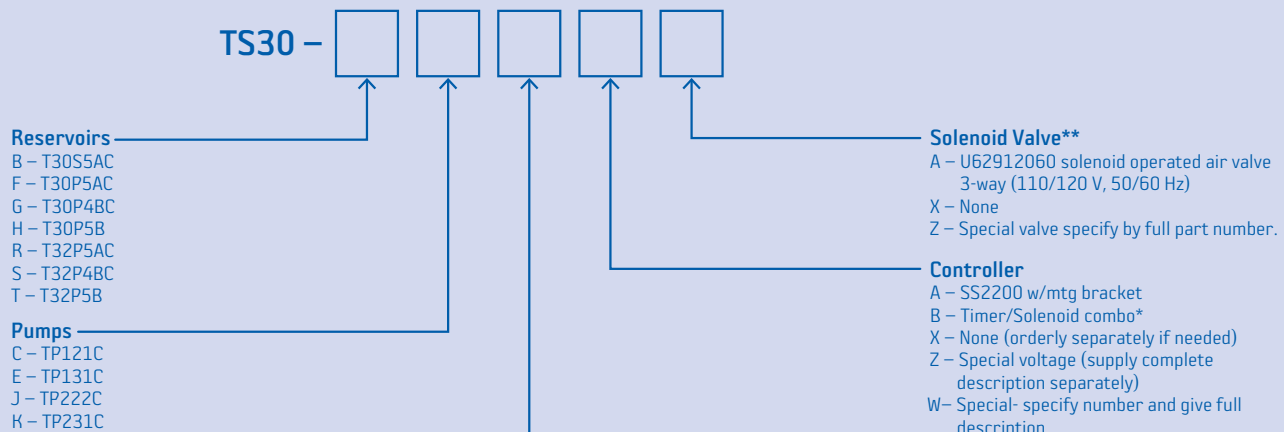

\*When this option is chosen, do not order solenoid valve separately (24476 and 20311-3). See page 29.  
\*\*These solenoid valves are normally used with single acting spring return pumps only (-1 Series).

# SureMatic Air-Operated (Single Stroke) Grease and Oil Pumps



## General

The SureMatic Lubricator comprises a piston discharge pump actuated by air, controlled by an electric solenoid 3-way valve. Models are available to handle grease and oil. Low level switch is standard on all models.

## Application

Unit discharges lubricant on single action air powered forward stroke and actuates all divider valves connected to the single line centralized distribution network.

Refer to the following documents for more info:

+ Datasheet #35485: SureMatic Lubricator

## Technical Data

Lubricator Reservoir Capacity	Oil 2.0, 3.5 and 5.0 liter / Grease 4, 7, and 10 pound
Discharge Range	1.0-8.0cc (adjustable) / .060-.480 cubic inch
Pressure Ratio/Lubricant Discharge/Inlet Air	18:1
Max/Min Permissible Inlet Air Pressure	150/40 psi
Maximum Stroke Rate (full stroke, 8cc)	Approximately 8 strokes/min.
Maximum Ambient Temperature Range	0-180°F
Materials	Aluminum pump; Buna N seals; acrylic reservoir

## Specification for Oil Pumps (150-8000 SSU)

Reservoir Capacity Liters	Air Inlet	Lube Outlet	Lubricant Oper. Press. Max.	Dimensions H x W x L (MM)	Part #
4 Pints (2 LT)	1/4" NPTF (F)	1/4" NPTF (F)	2700 PSI (186 bar) <sup>1</sup>	14" x 6-3/8 x 10" (356 x 162 x 254)	18137C
7 Pints (3.5 LT)				18" x 6-3/8 x 10" (457 x 162 x 254)	18138C
10 Pints (5 LT)				23" x 6-3/8 x 10" (584 x 162 x 254)	18139C

Note<sup>1</sup>: Max Lube Pressure @ 150 psi air pressure (10 bar)

Note<sup>2</sup>: For timers, see page 29

## Specifications for Grease Pumps (Up to NLGI #2)

Reservoir Capacity Liters	Air Inlet	Lube Outlet	Lubricant Oper. Press. Max.	Dimensions H x W x L (MM)	Part #
4 LB (2 KG)	1/4" NPTF (F)	1/4" NPTF (F)	2700 PSI (186 bar) <sup>1</sup>	14" x 6-3/8 x 10" (356 x 162 x 254)	18130-2.0C
7 LB (3.2 KG)				18" x 6-3/8 x 10" (457 x 162 x 254)	18130-3.5C
10 LB (4.6 KG)				23" x 6-3/8 x 10" (584 x 162 x 254)	18132C

Note<sup>1</sup>: Max Lube Pressure @ 150 psi air pressure (10 bar)

Note<sup>2</sup>: For timers, see page 29

# Motor Driven Oil Gear Pump

## General

The GPO Lubricator is a motor-driven gear pump that is designed for use with single line centralized lubricating systems utilizing progressive distributors or injectors. Standard features include: liquid level indicator, pressure gauge and strainer filler cap. An adjustable pressure regulating oil bypass valve is standard on Progressive systems and a dump valve is standard on Positive Displacement Injector (PDI) systems. Programmable controllers are available to operate the lubricator.

## Technical Data

Maximum Discharge Pressure	1000 psi (69 bar)
Operating Temperature Range	40°F to 105°F (5°C to 40°C)
Reservoir Capacities	6 liter, 12 liter, 30 liter
Discharge	275cc/min (Single Phase) 500cc/min (Three Phase)
Output Connection	1/4" NPT (left and right options)
Oil Viscosity	20-1500 cSt



## How to Order

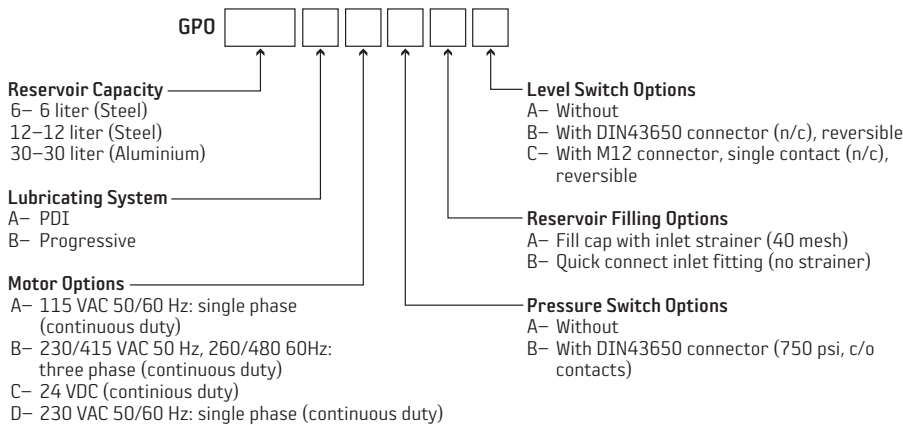

Refer to the following documents for more info:

+ Datasheet #35641: GPO Lubricator

## Dimensions

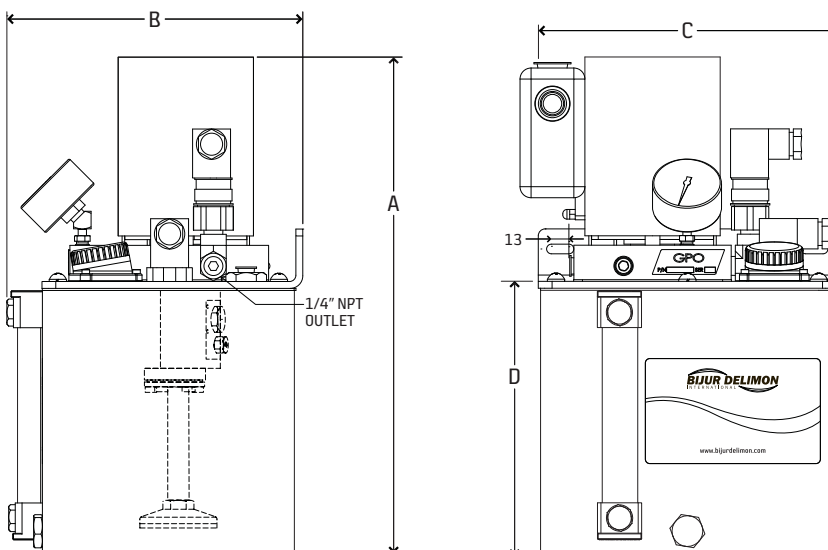

DIM	6 liter	12 liter	30 liter
A	360mm	318mm	468mm
B	215mm	260mm	340mm
C	229mm	370mm	490mm
D	200mm	156mm	291mm

# Dynamis & Dynamis Maxx

## Dynamis Maxx Lubricator

Dynamis Maxx Lubricators are electrically driven piston pumps designed for use with series progressive systems. These lubricators can be fitted with up to three independent piston elements providing positive displacement output to series progressive divider valves. Dynamis Maxx Lubricators are available with an integral pCo programmable controller, low level switch and various reservoir capacities. Operating voltages are 12 or 24 VDC.

### Technical Data

<b>Reservoir Capacity</b>	4 and 8 liter (8 and 16 lb.)
<b>Grease</b>	NLGI grade 000-2
<b>Relief Valve Setting</b>	2320 psi (160 bar) <sup>1</sup> & 4350 psi (300 bar)
<b>Discharge/min.</b>	2.9cc (0.18 cu. in.) Per element/outlet
<b>Operating Voltage</b>	12 or 24 VDC
<b>Outlet Connection</b>	8MM Tube fitting (or G1/4 port)
<b>Electrical Connections</b>	DIN 43650, 3 pole for power supply  Units with internal control have M12x1, 8 pole for status & M12X1, 4-pole for cycle switch.  Units without internal control have M12X1 4-pole for level switch connection.

Note<sup>1</sup>: Higher pressure settings may be available. Contact Bijur Delimon for details.



Dynamis Maxx Progressive Lubricator

### How to Order

Name	Voltage	Reservoir Capacity	Options	Relief Valve	Part #
Dynamis Maxx Progressive Lubricator	12 VDC	4 liter (8 lb.)	Low level switch & controller	160	37555
			Low level switch	160	37551
	24 VDC	4 liter (8 lb.)	Low level switch & controller	160	37553
			Low level switch & controller	300	37957
			Low level switch	160	37552
	24 VDC	8 liter (16 lb.)	Low level switch & controller	160	37554
			Low level switch & controller	300	37729
Low level switch			160	37552	

Refer to the following documents for more info:

+ Datasheet #35687: Dynamis Maxx Lubricator

# Multiport Pumps

## General

Rugged, compact, electric, motor-driven pump, equipped with fixed output pumping elements to discharge grease and oil over a wide operating range. Low level switches are available on some models. Available in 12 & 24 VDC, 110 VAC 1PH and 220/380 VAC 3 PH.

Up to three independent feed lines can be used with the MultiPort pump. The pump can be used with all single line progressive lubricating systems.

A selection of controller/monitors are available to operate MultiPort Pumps (SS2200, SMDC. See pages 28, 29).

## Specifications (All Models)

Operating Temp. Range	0°F to 120°F (-18 to 49°C)
Pumping Elements	1 to 3
Output Per Revolution	0.01 cu. in. (0.16cc)
Max. Working Pressure	3600 psi Grease, 2900 psi Oil
Oil Maximum	5000 SUS
Grease Maximum	NLGI # 2
Discharge Port	1/4-18 NPTF
Grease Fill Connection	Male filler fitting (quick disconnect)

## Elector Motor Specifications

Voltage	H.P. Rating	Full Load Amps	Protection
12 VDC	.068	4	IP44
24 VDC	.068	2	IP44
110 VAC	.08	1.83	IP55
220/380 VAC <sup>1</sup>	.08	.68	IP55

Note<sup>1</sup>: Can be used up to 440VAC for intermittent use only.

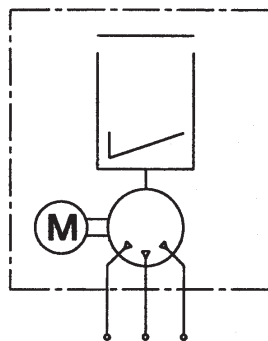

Multiport System

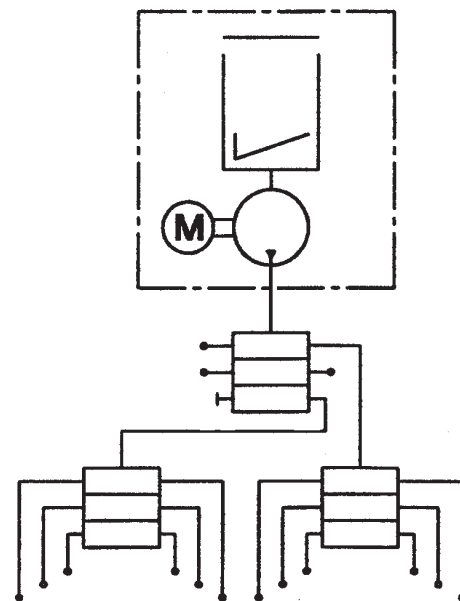

Multiport Progressive Divider System

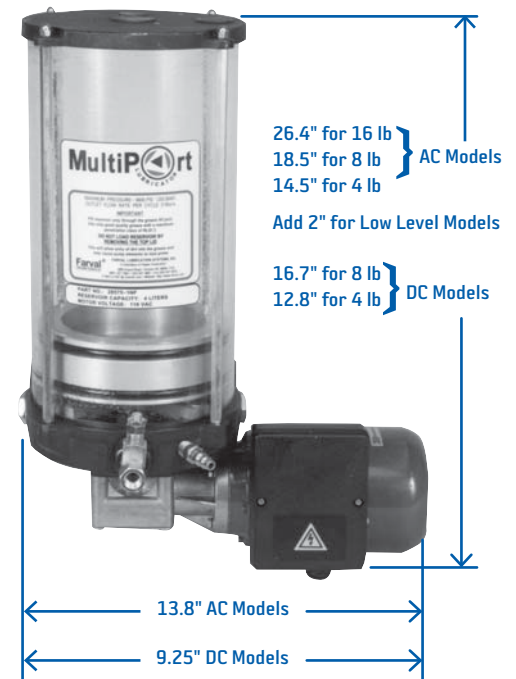

Refer to the following documents for more info:

+ Datasheet #35693: Multiport Lubricator

# Multiport Pumps

## 12 VDC Grease Models

Operates at 40 RPM at 68°F, 1000 PSI backpressure.

### 4 lb. Plastic Reservoir

Description	Part #
Single Outlet (center)	30785-1NF
Two Outlets (center and right)	30785-2NF
Three Outlets (all)	30785-3NF

*Note: 4 liter Oil reservoir - no low level is available Part # 51095-4E*

### 4 lb. Plastic Reservoir and Low Level Switch

Description	Part #
Single Outlet (center)	31099-1NF
Two Outlets (center and right)	31099-2NF
Three Outlets (all)	31099-3NF

*Note: 4 liter Oil reservoir - no low level is available Part # 51095-4E*

## 24 VDC Grease Models

Operates at 40 RPM at 68°F, 1,000 psi backpressure.

### 4 lb. Plastic Reservoir

Description	Part #
Single Outlet (center)	28566-1NF
Two Outlets (center and right)	28566-2NF
Three Outlets (all)	28566-3NF

### 4 lb. Plastic Reservoir and Low Level Switch

Description	Part #
Single Outlet (center)	30787-1NF
Two Outlets (center and right)	30787-2NF
Three Outlets (all)	30787-3NF

### 8 lb. Plastic Reservoir and Low Level Switch

Description	Part #
Single Outlet (center)	31037-1NF
Two Outlets (center and right)	31037-2NF
Three Outlets (all)	31037-3NF

*Note: 20lb plastic reservoir w/ low level is available. Part #51092E*

## 24 VDC Oil Models

Operates at 40 RPM at 68°F, 1,000 psi backpressure.

### 2 Liter Plastic Reservoir and Low Level Switch

Description	Part #
Single Outlet (center)	30787-1NFO

### 4 Liter Plastic Reservoir and Low Level Switch

Description	Part #
Single Outlet (center)	31037-1NFO



# Multiport Pumps

## 110 VAC, 1 Phase, 50/60 Hz Grease Models

Operates at 32 RPM (60 Hz) at 68°F, 1,000 psi backpressure.

### 4 lb. Plastic Reservoir

Description	Part #
Single Outlet (center)	28569-1NF
Two Outlets (center and right)	28569-2NF
Three Outlets (all)	28569-3NF

Note<sup>1</sup>: 4 lb plastic reservoir w/ low level is available - Part No. 41320-1NF  
 Note<sup>2</sup>: 16 lb plastic reservoir w/ low level is available - Part No. 59827-1NF

### 8 lb. Plastic Reservoir and Low Level Switch

Description	Part #
Single Outlet (center)	31801-1NF
Two Outlets (center and right)	31801-2NF
Three Outlets (all)	31801-3NF

## 110 VAC, 1 Phase, 50/60 Hz Oil Models

Operates at 32 RPM (60 Hz) at 68°F, 1,000 psi backpressure.

### 2 liter Plastic Reservoir and Low Level Switch

Description	Part #
Single Outlet (center)	41320-1NF0

### 4 liter Plastic Reservoir and Low Level Switch

Description	Part #
Single Outlet (center)	31801-1NF0

## 220/380 VAC, 3 Phase, 50/60 Hz Grease Models

Operates at 32 RPM (60Hz) at 68°F, 1,000 psi backpressure. Can be used up to 440 VAC for intermittent use only.

### 8 lb. Plastic Reservoir and Low Level Switch

Description	Part #
Single Outlet (center)	30559-1NF
Two Outlets (center and right)	30559-2NF
Three Outlets (all)	30559-3NF

Note: 4 lb plastic reservoir - no low level is available - Part No. 28570-1NF

### 16 lb. Metal Reservoir and Low Level Switch

Description	Part #
Single Outlet (center)	28730-1NF
Two Outlets (center and right)	28730-2NF
Three Outlets (all)	28730-3NF

## 220/380 VAC, 3 Phase, 50/60 Hz Oil Models

Operates at 32 RPM (60Hz) at 68°F, 1,000 psi backpressure. Can be used up to 440 VAC for intermittent use only.

### 4 liter Plastic Reservoir and Low Level Switch

Description	Part #
Single Outlet (center)	30559-1NF0

### 8 liter Steel Reservoir and Low Level Switch

Description	Part Number
Single Outlet (center)	28730-1NF0

# Air & Electric Grease Drum Pumps

## 55:1 High Pressure Air Operated Grease Drum Pumps

High pressure grease pumps handle all types of grease up to and including NLGI #2 directly from 35 lb., 120 lb. and 400 lb. grease containers. Highly efficient double-action pump design assures even flow of fluid, low noise level and low air consumption. Built in exhaust mufflers, standard.



Model F306      Model F308

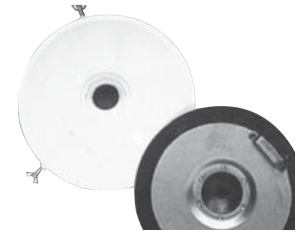

Steel Follower Plates

F306 (For 120 lb. Open Top Drum)		Part #
Includes:	55:1 Ratio pump with cover mounting adapter	F302
	Deluxe drum cover for 120 lb. drum	F1936
	Connecting hose installation hook-up kit	F903 <sup>1</sup>
F308 (For 400 lb. Open Top Drum)		Part #
Includes:	55:1 Ratio pump with cover mounting adapter	F304
	Deluxe drum cover for 400 lb. drum	F1938
	Connecting hose installation hook-up kit	F903 <sup>1</sup>
F335 (For 35 lb. Pail)		Part #
Includes:	55:1 Ratio pump with cover mounting adapter	F300
	Deluxe cover for 35 lb. pail	F1934
	Connecting hose installation hook-up kit	F903

Note<sup>1</sup>: F903 consists of 2' Air hose, 5' Grease hose, 1/4" Quick disconnect, and high pressure swivel coupler.

Note<sup>2</sup>: Order Follower Plate separately

## Technical Data

Max. Air Pressure	140 psi (10 BAR)
Min. Air Pressure	40 psi (3 BAR)
Avg. Air Consumption	5 cu. ft./min. (150L/min.)
Max. Delivery	40 cu. in./min. (650 cc/min.)

## Low Level Switch Kit

Description	Part #
120 lb. drum	LC10243
400 lb. drum	LC11036

Note<sup>1</sup>: Requires cover and follower plate - order separately.

Note<sup>2</sup>: Customer/user to provide 15/16" hole in cover.

Note<sup>3</sup>: Can be used with any style pump.

## Steel Follower Plates: Rubber Grommet and Wiper

Description	Part #
Follower for 35 lb. pail	F962
Follower for 120 lb. drum	F964
Follower for 400 lb. drum	F966

## Electric Grease Drum Pumps

AC or DC electric barrel pumps will replace the air or hydraulic operated pumps now used for lube systems on mobile or stationary equipment. Installation is cleaner - no air or hydraulic lines to install. Simply wire into the machines 12, 24, or 110 Volt supply. Pressure rated to 4000 psi. Will fit original refinery 35 and 120 lb. drums. All models include drum cover, and follower plate.

## Electric Barrel Pump Specifications

Part #	Voltage AC/DC	Container Size	Pressure Max PSI	Lube Flow Output/Minute	Amp Draw Normal	Amp Draw Spike
FEP312	12 VDC	35 lb. pail	4000	14.5 cu. in.	See Note <sup>1</sup>	80 amps
FEP322	12 VDC	120 lb. drum		14.5 cu. in.	See Note <sup>1</sup>	80 amps
FEP712C	24 VDC	35 lb. pail		12.0 cu. in.	See Note <sup>2</sup>	40 amps
FEP722C	24 VDC	120 lb. drum		12.0 cu. in.	See Note <sup>2</sup>	40 amps
FEP812	115 VAC 50/60 Hz	35 lb. pail		10.3 cu. in.	See Note <sup>3</sup>	5 amps
FEP822	115 VAC 50/60Hz	120 lb. drum		10.3 cu. in.	See Note <sup>3</sup>	5 amps

Note<sup>1</sup>: 12 VDC 15-20 amp draw @ free flow. 30-40 amp draw @ 3000 psi | Note<sup>2</sup>: 24 VDC 10 amp draw @ free flow. 15-20 amp draw @ 3000 psi  
 Note<sup>3</sup>: 120 VAC 5 amp draw @ free flow or 3000 psi | Note<sup>4</sup>: Lube Outlet port is 1/4" NPT (F)



NOTE: Lube containers supplied by others.

## Drum Heated Insulated Blankets

Description	Part #
Fits 120 lb. Drum (15 gal/57 liter)	37506
Fits 400 lb. Drum (55 gal/208 liter)	55286

Refer to the following documents for more info:

+ Datasheet #35975: Electric Drum Pumps

+ Datasheet #35745: Drum Heater Blankets

# Air/Oil Systems

## Description

Air/Oil Systems deliver ultra efficient lubrication and cooling to heavy duty, high performance bearings operating in adverse conditions. Customized air/oil stations and zone boxes deliver precise oil and air flow to bearings and gears for sustained peak performance. Pump stations can be air operated or electric motor driven. A full line of controllers and monitoring packages are provided to control system performance.

## Industries and Applications Include

<b>Steel</b>	Spindles, saws, rolling mills, roller tables, levelers, continuous casters, fan bearings, pinch & shape roll, guides, gears, work roll & back roll
<b>Paper</b>	Chains, gear cases, roll additions, dryers
<b>General</b>	Any bearing that can benefit from air/oil pressurization or application

## Basic Principle of Air/Oil Lubrication

The valves are mounted directly on top of the M2500G divider valves.

Oil is discharged from the alternate outlet ports on top of the M2500G valve assembly and enters the H2500 section. Compressed air enters the assembly through the center of the air/oil block, mixes with the oil and goes out the outlet port.

The oil is carried along the inside of the tube by the air flow, and when piped into a bearing the oil lubricates the bearing and air flow acts to prevent moisture and contamination from entering the bearing and assists in reducing bearing temperature.

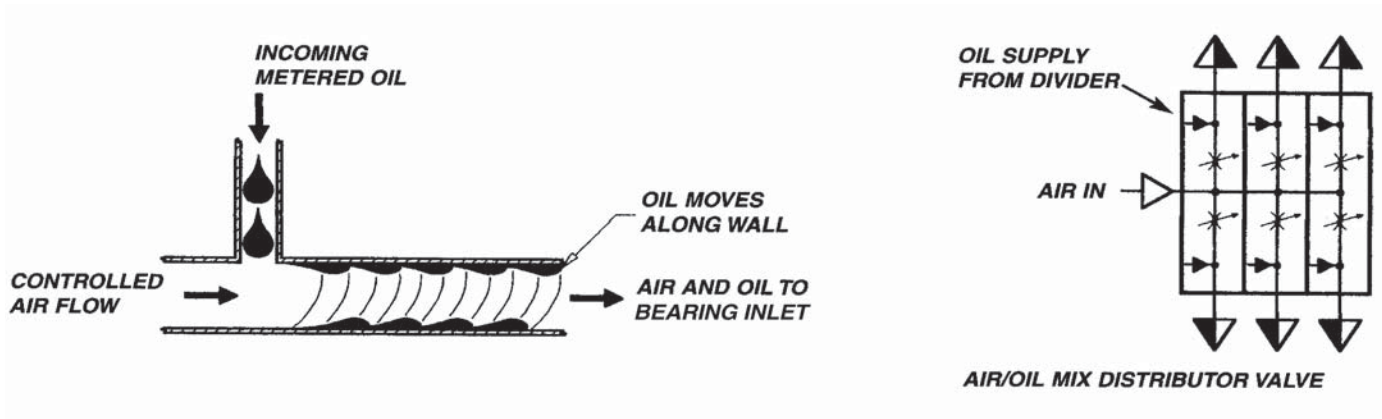

# Air/Oil Systems

## Air/Oil Valves

### Features That Make the Difference

- Air/Oil mixing sections mount directly onto M2500G Series and most competitors modular divider assemblies.
- Ability to mount 1 to 8 air/oil valves on a divider assembly, serving from 1-16 air/oil lube points per assembly.
- Manifolds can dispense oil only or air/oil from different ports on the same divider assembly.
- Oil volume is supplied through standard discharge sections ranging from .005 to .080 cu. in. per discharge.

### 3 Section Air/Oil Valve Assembly

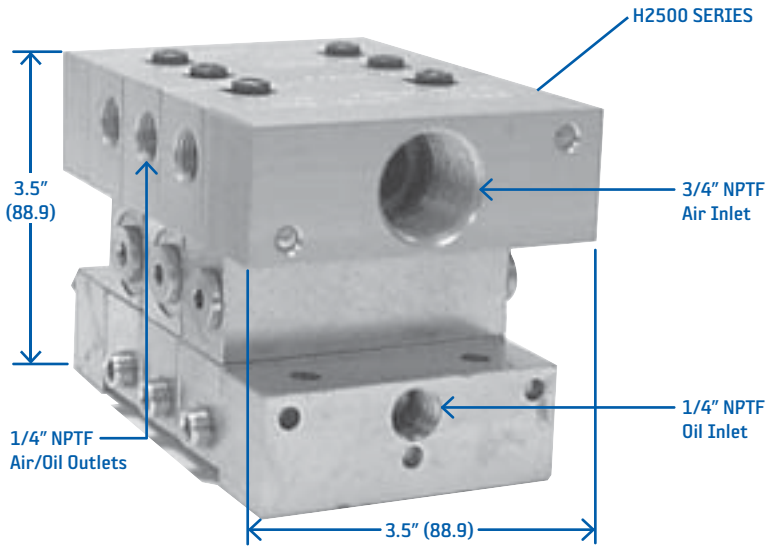

### H2500 Specifications

Max Air Flow	20 SCFM
Max Air Pressure	100 PSI (7 BAR)
Seals	Viton
Material	Anodized Aluminum

### H2500 Ordering Information

Description	Part #
Inlet	34134 & U1720120S
End	34136
Mixing Valve*	H2500B
Tie Rod (2 req'd)	MCR2505-3 thru 8
Nut (2 req'd)	U251A

*Note\*: Mixing Valve's include all seals, mounting screws, flush fit plugs, etc.*

# Lube Point Monitor - Oval Gear Mechanism

## General

The 55105 Lube Point Monitor is an accurate oval gear mechanism that incorporates two magnets into one of the nylon oval gears. The body incorporates a reed switch which senses the magnet passing. Lubricant entering the 55105 causes the gears to rotate. Each pulse equates to an approximate displacement of 0.040 cu. in. (.65cc). The monitoring of the 55105 is done with any PLC. The feedback from the 55105 will assure that lubricant has reached the inlet of critical lubrication points.

## Application

The 55105 Lube Point Monitor is intended to be mounted at or near the lubrication point inlet. It can be used with any type of grease or oil system (Dualine Progressive/PDI). Due to the nature of the internals, proper filtration is required to keep contaminants out of the monitor body.

## Technical Data

Flow	0-2500cc/min.	
Maximum Pressure	10153 psi (700 bar)	
Accuracy	73%	
Vibrations	20 g (10-20000 Hz)	
Life Time	10 <sup>9</sup> pulses	
Temperature	-4°F to 158°F (-20°C to 70°C)	
Connections	1/8" NPT	
Material	Aluminum	
Weight	0.186 kg	
Lubricant	ISO VG 32 Oil to NLGI Grade 2 Grease	
IP Enclosure Rating	IP-67	
Connection	4-pole M12 x 1 (male)	
Switch Rating	Maximum Voltage	0-24 VDC
	Maximum Current	0.20 amp

## Wiring

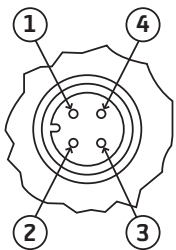

PIN #	Description	Wire Color
1	Common	Brown
4	Signal	Black

Note: See page 12 for cables.



Lube Point Monitor (Part #55105)



Lube Point Monitor shown with bearing. (Bearing not included)

Refer to the following documents for more info:

+ Datasheet #35978: Lube Point Monitor

# Strainers & Timers

## LS Strainers

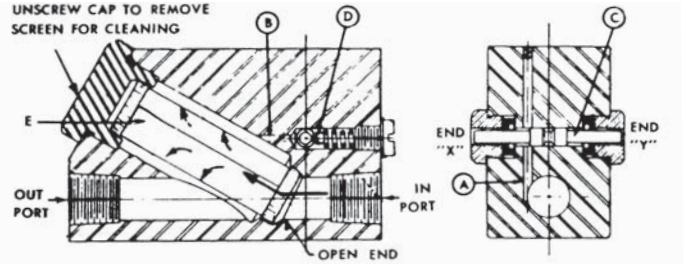
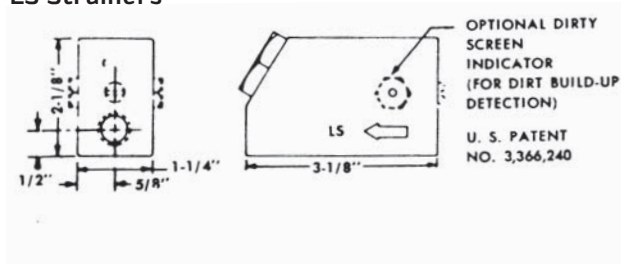

1. LS Line Strainers remove foreign particles from grease and oil lines in lubricating systems. Withstand up to 5000 psi working pressure non-shock.
2. Flow rate and ratio of open screen area to pipe diameter are:

Size (NPT)	Flow Rate (GPM)*	Ratio of Open Screen Area/Pipe DIA	
		Perforated Metal Screen Type (500 Micron)	Wire Mesh Screen Type (75 & 150 Micron)
1/4	2	6:1	7:1
3/8	5	3.5:1	4:1

*Note\*: Based on 225 SSU oil at 100F and 20 ft/sec. velocity.*

3. The dirty screen indicator option requires a differential pressure between 300 and 500 psi for activation.

## Replacement Screens

Description	Part #
25 Micron Screen (Oil Only Up To 500 SSU)	LS0205103
150 Micron Screen (Oil Only Up To 2000 SSU)	LS0205106
500 Micron Screen (Oil Over 2000 SSU & All Grease)	LS0205120

## How to Order

**Typical Ordering Code: LS Strainer (Part #LS-02-2-03-5)**

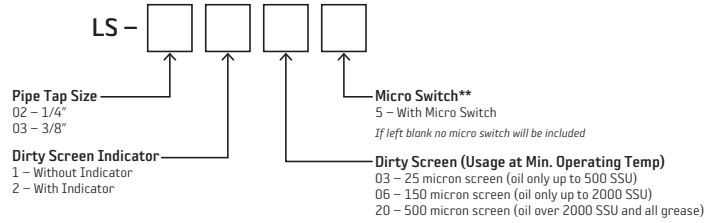

**\*\*Micro Switch available ONLY with Dirty Screen Indicator (2 Option). Example: LS-03-120 is the order code for a 3/8" PT Strainer without indicator and with a 500 micron screen.**

## SMDC Controller (Direct Current Voltage Model)

The SMDC Controller is a multi-purpose programmable controller used with 12-24 VDC lubrication systems. Controller settings are saved whenever power is interrupted. Up to four operating modes can be selected which allows the controller to be used with various lubrication system designs. A voltage selector switch is located inside the enclosure for both 12 and 24 VDC service.

## Features

- Digital status display on front cover for easy programming
- System monitoring capabilities (cycle switch and low level switch)



## Technical Data

Operating Voltage	12VDC, 24VDC (factory setting)	
IP Enclosure Rating	External terminal strip	IP-47
	Liquid tight connector	IP-67
Ambient Temperature	-4 °F to 104 °F (-20C to 40 °C)	

## Controller Status LEDs

Red Steady	Lubrication cycle
Yellow Steady	Alarm
Green Steady	Power supply on
None Lit	No input to controller

## How to Order

Name	Description	Part #
SMDC Controller	Controller with external terminal strip	33346ME
	Controller with liquid tight connector	33346E

Refer to the following documents for more info:  
+ Datasheet #46911: SMDC Controller

# Miscellaneous Controllers

## SS2200 Controller

- Simple three key programming
- Controls both single line and dualine lubrication systems
- Operates electric or air driven pumps
- Time or machine cycle based operation
- Programmable for remote fault indication and emergency machine shutdown
- LED indicators and numerical displays monitor system operation
- EEPROM permanently stores programming without battery backup

The SS2200 is a microprocessor-based programmable controller designed to operate Single line and Dualine central lubrication systems. The SS2200 is housed in a NEMA 4X polycarbonate enclosure with a transparent cover. Visible through the cover are LED indicators for Idle, Lube and Fault modes, and a three-digit numerical display used for programming and monitoring lube system operation.

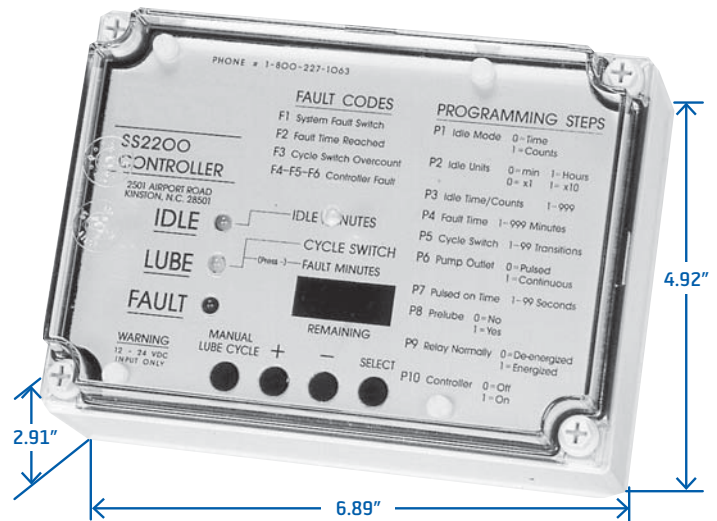

Refer to the following documents for more info:

+ Datasheet #24735 SS2200 Controller

## Specifications

<b>Input</b>	115 VAC 50/60 Hz Over voltage protected	
<b>Outputs</b>	<b>Pump</b>	Pulsed or Continuous, Form A, 115 VAC, 5 Amp. Inrush, 2 Amp. Continuous
	<b>Cycle Switch</b>	12-16 VDC, 12-16 ma. DC
	<b>Fault Switches</b>	12-16 VDC, 12-16 ma. DC
<b>Fault Relay Contacts</b>	2 Amp., 125 VAC	
<b>Enclosure</b>	NEMA 4X, Polycarbonate	
<b>Ambient Temperature</b>	+20°F. to 120°F	
<b>Vibration</b>	1.5g	
<b>Permanent Memory</b>	EEPROM (No Battery)	

## Programming

<b>Idle Time</b>	1-999 Hours, 1-999 Minutes 1-999 or 10-9990 Machine Counts
<b>Cycle Completion Time</b>	1-999 Minutes
<b>Cycle Switch Counts</b>	1-99 Counts
<b>Pulsed Output On-Time</b>	1-99 Seconds
<b>Prelube on Power-Up</b>	Yes/No
<b>Fault Relay</b>	Normally Energized/ Normally De-energized
<b>Controller</b>	On/Off

## Timer and Solenoid Valve for Pneumatic Operated Pumps

A compact timer which mounts directly to a solenoid valve having DIN 43650 Form A electrical terminations. Unit has four operating modes, with eight time ranges. Final time range settings are adjusted by potentiometers. Two red light emitting diodes indicate power 'ON' and output energized (solenoid 'ON').

### Technical Data (Solenoid Valve)

110/120 50/60 Hz
3-Way-2-position - normally closed
1/8" NPT Ports
150 psi Max

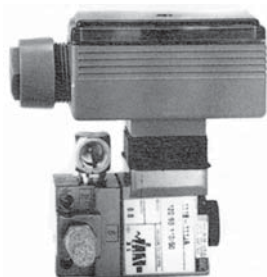

### How to Order

Name	Part #
Timer	24476
Solenoid Valve	20311-3

### Technical Data (Timer – Part #24476)

<b>Supply Voltage</b>	110-230V, 50/60 Hz (+/- 10%)
<b>Power Consumption</b>	1.0W maximum
<b>Switching Load</b>	1 max = 0.5 A at supply voltage 110/230v, 50/60 Hz
<b>Classification</b>	Ip 65, air gaps and leakage paths according to VDE 0100
<b>Body Material</b>	Polyamide plastic
<b>Working Temp. Range</b>	32°-130°F (0°-55°C)
<b>Indicator</b>	LED connected power supply LED energized load
<b>Adjustment</b>	Basic function and time range via DIP switch settings Precision time adjustment via potentiometer
<b>Time Range</b>	Adjustable from .5 seconds to 10 hours

## Innovators of engineered lubrication technology **since 1923**

Bijur Delimon International has ISO 9001:2000 and ISO 14001:2000 quality certified manufacturing facilities around the world, so your centralized lubrication system meets the highest industry quality standards. It's all part of our commitment to quality and customer service.



**BIJUR DELIMON NORTH AMERICA**  
2250 Perimeter Park Drive, Suite 120  
Morrisville, NC 27560

(252) 527 6001 **LOCAL**  
(800) 227 1063 **TOLL-FREE**  
(252) 527 3533 **FAX**

[WWW.BIJURDELIMON.COM](http://WWW.BIJURDELIMON.COM)

**SL2800 • R25 02/16**