

Custom

Fittings Ltd

CF100D 2007

www.customfittings.com



60° CONE JOINT HYDRAULIC CONNECTORS & ADAPTORS IN 316 STAINLESS STEEL

MATERIAL
1.750" ALF HEX E
BS 970.316 811/531
MACHINE
SMOOTH M/C
ALLOWER

DRAWN
E.F.
10-5-93

UNION
OF T00
CLA 3

ENLARGED DETAIL
OF THRD UCUT

MATERIAL
2.000" ALF HEX
BS 970.316 811/531
MACHINE
SMOOTH M/C
ALLOWER

TITLE
1/4" BSP D(CS)

SCALE
FULL

MADE IN JAPAN

ISO 9001

**BUREAU VERITAS
Certification**



008

60° Cone Joint Hydraulic Connectors and Adaptors in accordance with BS.5200 in 316 Stainless Steel

- Most items in range now available Ex-Stock.
- Elbows, Tees and Crosses are manufactured from forged or plate bar conforming to specification ASTM.A. 182.316L and A.240.316/316.L Bar stock parts to BS.970.316.S11/S31.
- Fabricated Elbows are either butt or socket welded depending on size. Similarly nuts are crimp or slip-back.
- Entire range machined within our own works which are BS EN ISO 9001 : 1994 certified. Extensive use is made of CNC machine tools to ensure utmost accuracy and finish.
- Control of material ensures Mill Certificates can be issued for all fittings.

CONTENTS

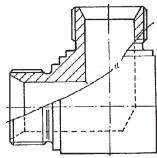

**Male (CS)
90° Elbow**

EBM-200 - Page 4

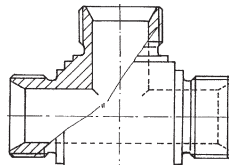

**Male (CS)
Tee**

TM-200 - Page 4

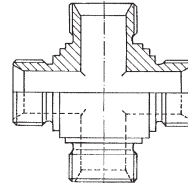

**Male (CS)
Cross**

CRM-200 - Page 5

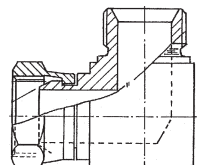

**90° Swivel
Nut Elbow**

EBSN-200 - Page 5

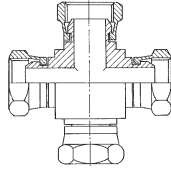

**Female (CS)
Cross**

CRF-200 - Page 8

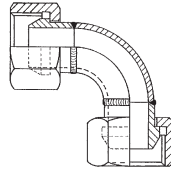

**Female (CS) 90°
Swept Elbow**

ESF-200 - Page 9

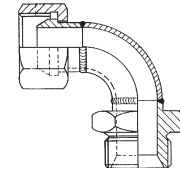

**90° Swivel Nut
Swept Elbow**

ESSN-200 - Page 9

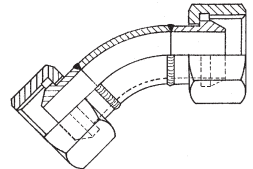

**Female (CS) 45°
Swept Elbow**

ESFF-200 - Page 10

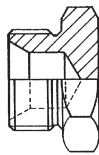

**Plug
(CS)**

PC-2BP - Page 13

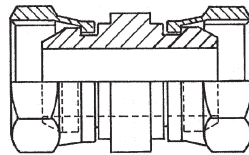

**Female/Female
(CS) Adaptor**

FFA-200 - Page 13

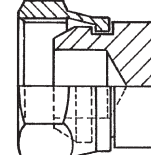

**Cap
(CS)**

CC-200 - Page 14

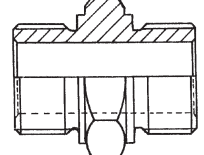

**Male (OR)
Equal Adaptor**

AEO-200 - Page 14

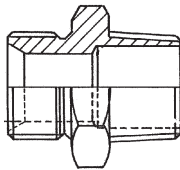

**Male (CS) x
Taper Adaptor
NPT**

ACT-2NT - Page 19

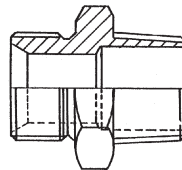

**Male (CS) x
Taper Adaptor
BSP'T'**

ACT-2BT - Page 20

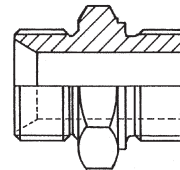

**Male (CS) x
Male (OR) Adaptor
BSP'P'**

ACO-2BP - Page 21

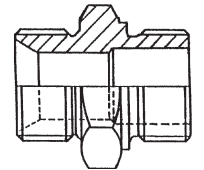

**Male (CS) x
Male (OR) Adaptor
SAE**

ACO-2SA - Page 21

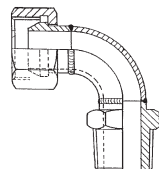

**Male Taper
90° Swept Elbow
NPT**

ESSN-2NT - Page 24

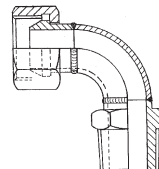

**Male Taper
90° Swept Elbow
BSP'T'**

ESSN-2BT - Page 25

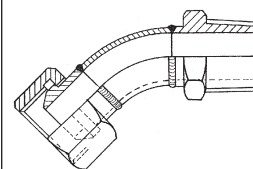

**Male Taper
45° Swept Elbow
NPT**

ESSNF-2NT - Page 25

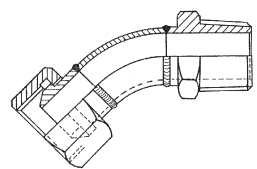

**Male Taper
45° Swept Elbow
BSP'T'**

ESSNF-2BT - Page 26

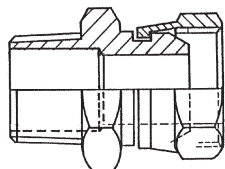

**Swivel Female x
Taper Male Adaptor
NPT**

FST-2NT - Page 31

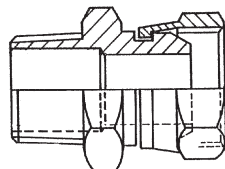

**Swivel Female x
Taper Male Adaptor
BSP'T'**

FST-2BT - Page 31

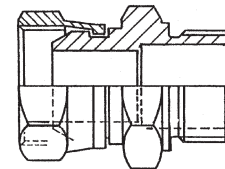

**Swivel Female x
Male (OR) Adaptor
BSP'P'**

FSO-2BP - Page 32

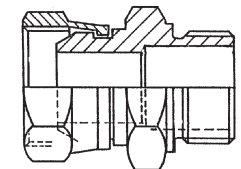

**Swivel Female x
Male (OR) Adaptor
SAE**

FSO-2SA - Page 32

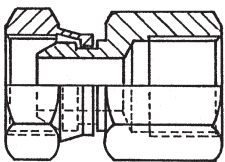

**Swivel Female x
Fixed Female
SAE**

FSFF-2SA - Page 35

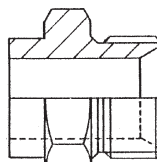

**Fixed Male
'CS'**

FMC-125 - Page 36

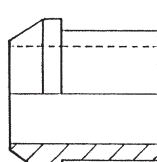

**Nipple
'CS'**

CN-125 - Page 36

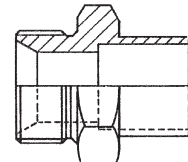

**Hex Male for
Socket Weld Tube
'CS'**

FMCS-125 - Page 37

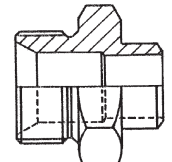

**Hex Male for
Butt Weld Tube
'CS'**

FMCB-125 - Page 37

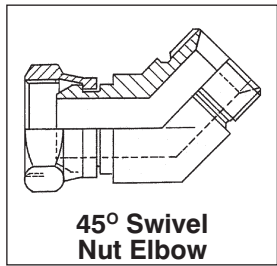

45° Swivel Nut Elbow

ESBNF-200 - Page 6

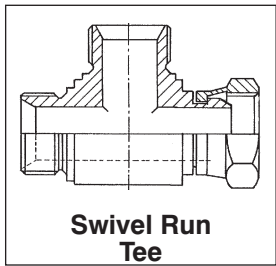

Swivel Run Tee

TSR-200 - Page 6

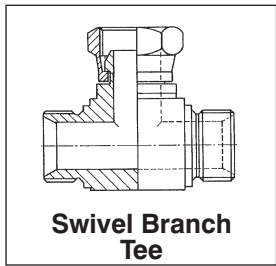

Swivel Branch Tee

TSB-200 - Page 7

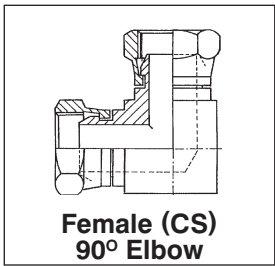

Female (CS) 90° Elbow

EBF-200 - Page 7

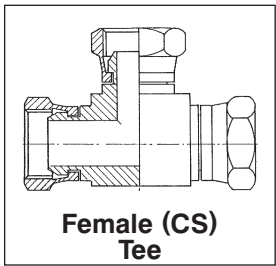

Female (CS) Tee

TF-200 - Page 8



45° Swivel Nut Swept Elbow

ESSNF-200 - Page 10

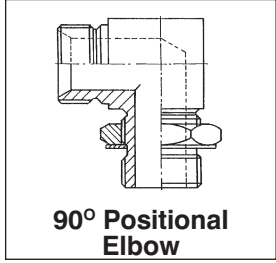

90° Positional Elbow

EP-2BP - Page 11

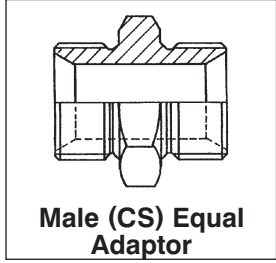

Male (CS) Equal Adaptor

AE-200 - Page 11

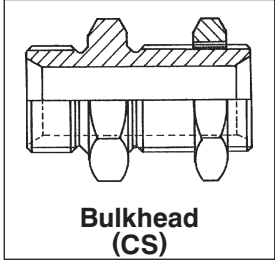

Bulkhead (CS)

BUK-200 - Page 12

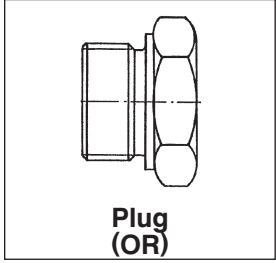

Plug (OR)

PO-2BP - Page 12

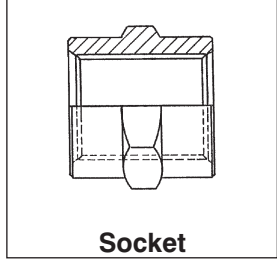

Socket

S-200 - Page 15

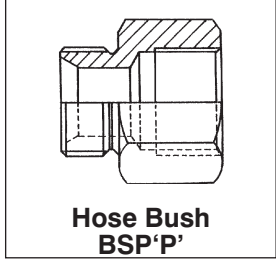

Hose Bush BSP'P'

HB-2BP - Page 16

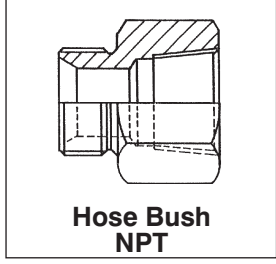

Hose Bush NPT

HB-2NT - Page 17

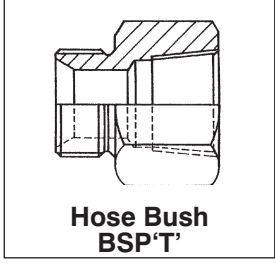

Hose Bush BSP'T'

HB-2BT - Page 17

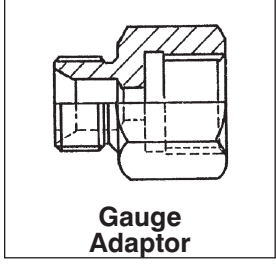

Gauge Adaptor

GAC-2BP - Page 18

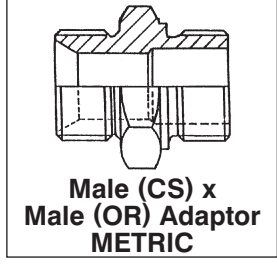

Male (CS) x Male (OR) Adaptor METRIC

ACO-2M - Page 22

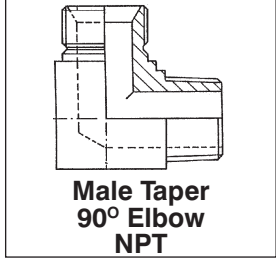

Male Taper 90° Elbow NPT

EBM-2NT - Page 22

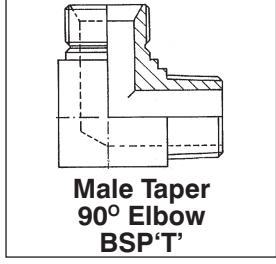

Male Taper 90° Elbow BSP'T'

EBM-2BT - Page 23

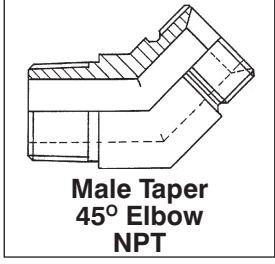

Male Taper 45° Elbow NPT

EBMF-2NT - Page 23

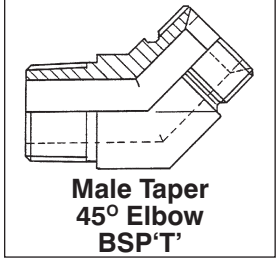

Male Taper 45° Elbow BSP'T'

EBMF-2BT - Page 24

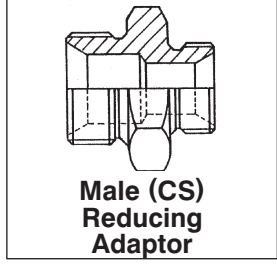

Male (CS) Reducing Adaptor

AR-200 - Page 27

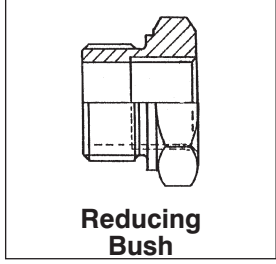

Reducing Bush

B-200 - Page 28

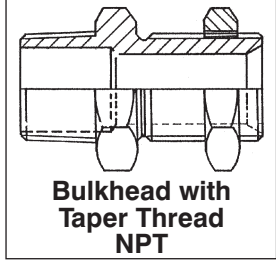

Bulkhead with Taper Thread NPT

BUT-2NT - Page 29

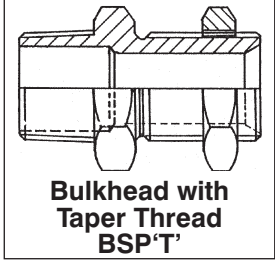

Bulkhead with Taper Thread BSP'T'

BUT-2BT - Page 29

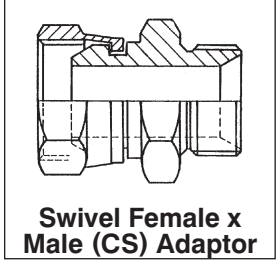

Swivel Female x Male (CS) Adaptor

FSC-2BP - Page 30

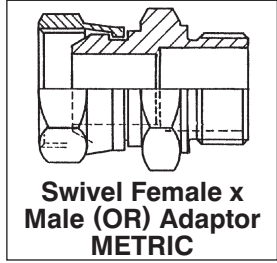

Swivel Female x Male (OR) Adaptor METRIC

FSO-2M - Page 33

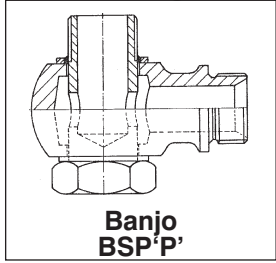

Banjo BSP'P'

BAC-2BP - Page 33

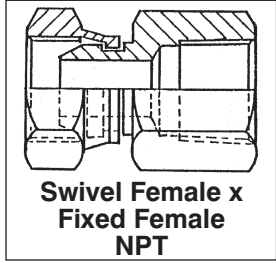

Swivel Female x Fixed Female NPT

FSFF-2NT - Page 34

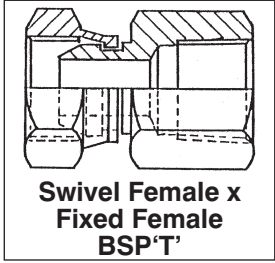

Swivel Female x Fixed Female BSP'T'

FSFF-2BT - Page 34

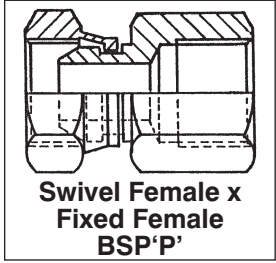

Swivel Female x Fixed Female BSP'P'

FSFF-2BP - Page 35

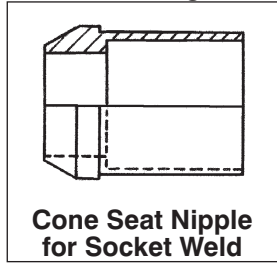

Cone Seat Nipple for Socket Weld

CNS-125 - Page 38

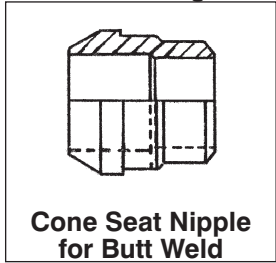

Cone Seat Nipple for Butt Weld

CNB-125 - Page 38

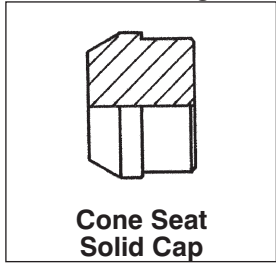

Cone Seat Solid Cap

CCSN-200 - Page 39

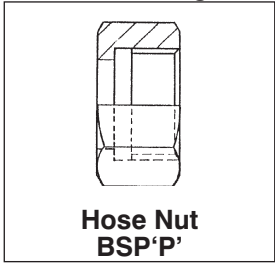

Hose Nut BSP'P'

HN-125 - Page 39

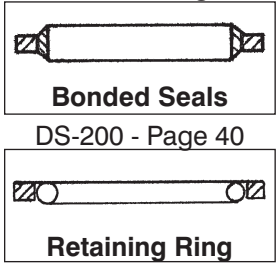

Bonded Seals

DS-200 - Page 40

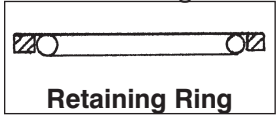

Retaining Ring

RT-200 - Page 40

BSP'P' (CS) MALE/MALE 90° ELBOW

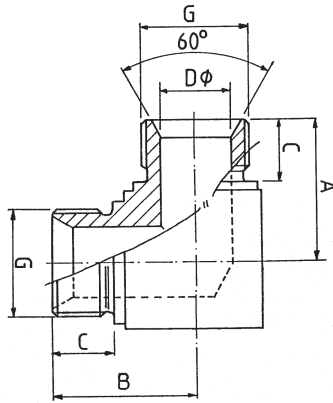

Part No.	BSP'P' Thread Size	A	B	C	D
	G				
EBM-200-2	1/8"	25.4	25.4	8.1	3.5
EBM-200-4	1/4"	25.4	25.4	11.1	5.1
EBM-200-6	3/8"	28.5	28.5	12.1	8.1
EBM-200-8	1/2"	32.5	32.5	14.1	11.1
EBM-200-10	5/8"	36.5	36.5	16.1	14.3
EBM-200-12	3/4"	41.3	41.3	16.1	16.6
EBM-200-16	1"	44.5	44.5	19.1	22.2
EBM-200-20	1 1/4"	50.8	50.8	20.1	28.6
EBM-200-24	1 1/2"	59.1	59.1	22.1	33.3
EBM-200-32	2"	77.5	77.5	25.1	46.1

BSP'P' (CS) ALL MALE EQUAL TEE

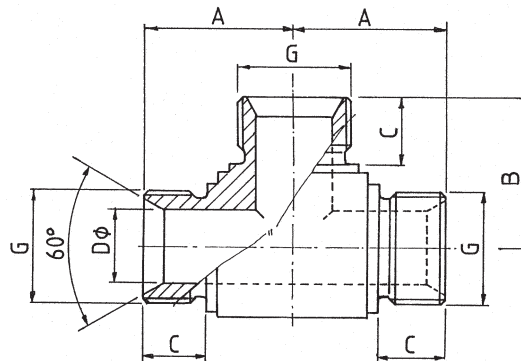

Part No.	BSP'P' Thread Size	A	B	C	D
	G				
TM-200-2	1/8"	22.2	22.2	8	3.5
TM-200-4	1/4"	22.2	22.2	11	4.7
TM-200-6	3/8"	25.4	25.4	12	8.1
TM-200-8	1/2"	30.5	30.5	14	11.1
TM-200-10	5/8"	31.7	31.7	16	14.2
TM-200-12	3/4"	38.1	38.1	16	16.6
TM-200-16	1"	44.4	44.4	19	22.2
TM-200-20	1 1/4"	50.8	50.8	20	28.5
TM-200-24	1 1/2"	57.1	57.1	22	33.3
TM-200-32	2"	63.1	63.1	25	46.1

BSP'P' (CS) ALL MALE EQUAL CROSS

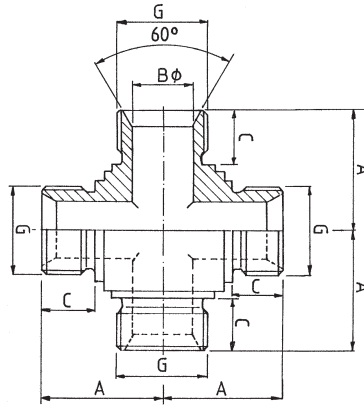

Part No.	BSP'P' Thread Size G	A	B	C
CRM-200-2	1/8"	22.2	3.5	8
CRM-200-4	1/4"	22.2	4.7	11
CRM-200-6	3/8"	25.4	8.1	12
CRM-200-8	1/2"	30.5	11.1	14
CRM-200-10	5/8"	31.7	14.2	16
CRM-200-12	3/4"	38.1	16.6	16
CRM-200-16	1"	44.4	22.2	19
CRM-200-20	1 1/4"	50.8	28.5	20
CRM-200-24	1 1/2"	57.1	33.3	22
CRM-200-32	2"	63.1	46.1	25

BSP'P' (CS) MALE/SWIVEL FEMALE 90° ELBOW

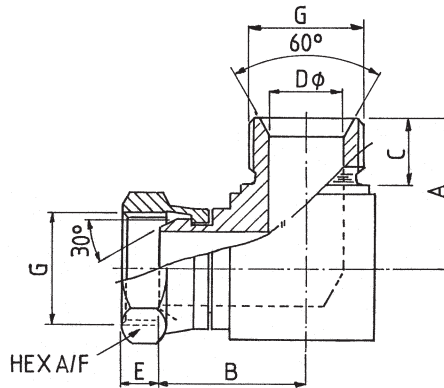

Part No.	BSP'P' Thread Size G	A	B	C	D	E	HEX
EBSN-200-2	1/8"	25.4	25.4	8.1	3.5	4.1	14.3
EBSN-200-4	1/4"	25.4	28.6	11.1	5.1	4.2	18.1
EBSN-200-6	3/8"	28.5	31.5	12.1	7.2	4.6	22.2
EBSN-200-8	1/2"	32.5	31.5	14.1	11.1	6.8	25.6
EBSN-200-10	5/8"	36.5	37.3	16.1	12.7	10.1	28.6
EBSN-200-12	3/4"	41.3	42.5	16.1	15.5	8.7	31.7
EBSN-200-16	1"	44.5	49.5	19.1	19.8	10.1	38.1
EBSN-200-20	1 1/4"	50.8	54.1	20.1	26.1	10.5	47.2
EBSN-200-24	1 1/2"	59.1	59.8	22.1	31.7	12.2	56.4
EBSN-200-32	2"	77.5	79.4	25.1	41.3	15.1	69.8

BSP'P' (CS) MALE/SWIVEL FEMALE 45° ELBOW

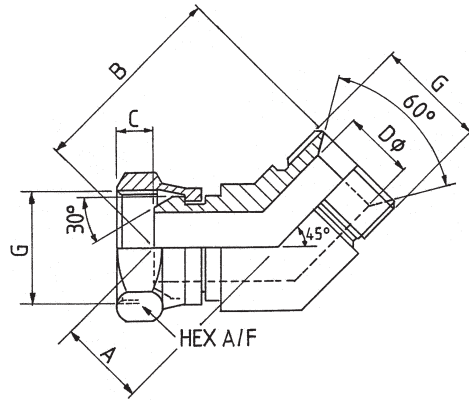

Part No.	BSP'P' Thread Size G	A	B	C	D	E	HEX
EBSNF-200-2	1/8"	14.9	37.1	8.1	3.5	4.1	14.3
EBSNF-200-4	1/4"	14.9	39.2	11.1	5.1	4.2	18.1
EBSNF-200-6	3/8"	17.3	45.6	12.1	7.2	4.6	22.2
EBSNF-200-8	1/2"	18.2	50.4	14.1	11.1	6.8	25.6
EBSNF-200-10	5/8"	19.9	53.2	16.1	12.7	10.1	28.6
EBSNF-200-12	3/4"	22.4	59.5	16.1	15.5	8.7	31.7
EBSNF-200-16	1"	24.9	62.1	19.1	19.8	10.1	38.1
EBSNF-200-20	1 1/4"	25.2	65.9	20.1	26.1	10.5	47.2
EBSNF-200-24	1 1/2"	27.9	66.2	22.1	31.7	12.2	56.4
EBSNF-200-32	2"	39.6	112.5	25.1	41.3	15.1	69.8

BSP'P' (CS) MALE/SWIVEL FEMALE RUN TEE

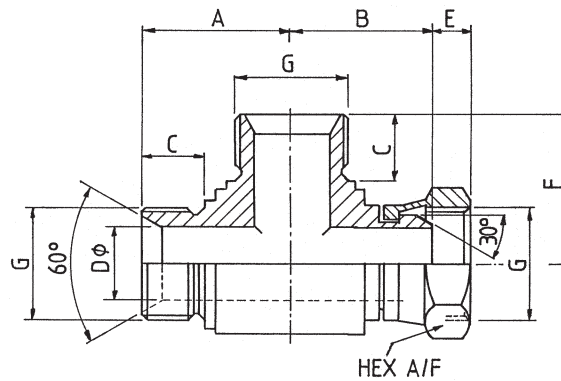

Part No.	BSP'P' Thread Size G	A	B	C	D	E	F	HEX
TSR-200-2	1/8"	22.2	25.4	8	3.5	4.1	22.2	14.3
TSR-200-4	1/4"	22.2	28.6	11	4.7	4.2	22.2	18.1
TSR-200-6	3/8"	25.4	31.7	12	8.1	4.6	25.4	22.2
TSR-200-8	1/2"	30.5	35.5	14	11.1	6.8	30.5	25.6
TSR-200-10	5/8"	31.7	40.1	16	14.2	10.1	31.7	28.6
TSR-200-12	3/4"	38.1	42.5	16	16.6	8.7	38.1	31.7
TSR-200-16	1"	44.4	50.1	19	22.2	10.1	44.4	38.1
TSR-200-20	1 1/4"	50.8	58.1	20	28.5	10.5	50.8	47.2
TSR-200-24	1 1/2"	57.1	59.5	22	33.3	12.2	57.1	56.4
TSR-200-32	2"	63.1	80.1	25	46.1	15.1	63.1	69.8

BSP'P' (CS) MALE/SWIVEL FEMALE BRANCH TEE

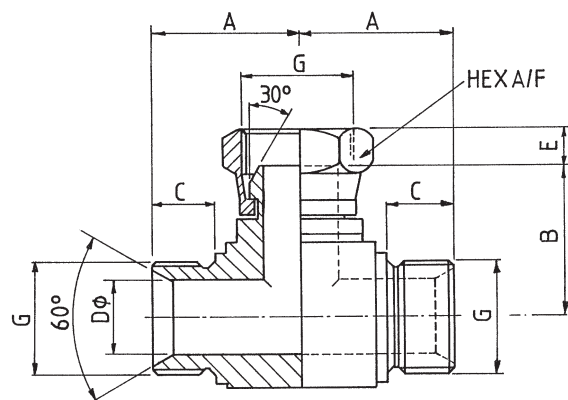

Part No.	BSP'P' Thread Size G	A	B	C	D	E	HEX
TSB-200-2	1/8"	22.2	25.4	8	3.5	4.1	14.3
TSB-200-4	1/4"	22.2	28.6	11	4.7	4.2	18.1
TSB-200-6	3/8"	25.4	31.7	12	8.1	4.6	22.2
TSB-200-8	1/2"	30.5	35.5	14	11.1	6.8	25.6
TSB-200-10	5/8"	31.7	40.1	16	14.2	10.1	28.6
TSB-200-12	3/4"	38.1	42.5	16	16.6	8.7	31.7
TSB-200-16	1"	44.4	50.1	19	22.2	10.1	38.1
TSB-200-20	1 1/4"	50.8	58.1	20	28.5	10.5	47.2
TSB-200-24	1 1/2"	57.1	59.5	22	33.3	12.2	56.4
TSB-200-32	2"	63.1	80.1	25	46.1	15.1	69.8

BSP'P' (CS) SWIVEL FEMALE/SWIVEL FEMALE 90° ELBOW

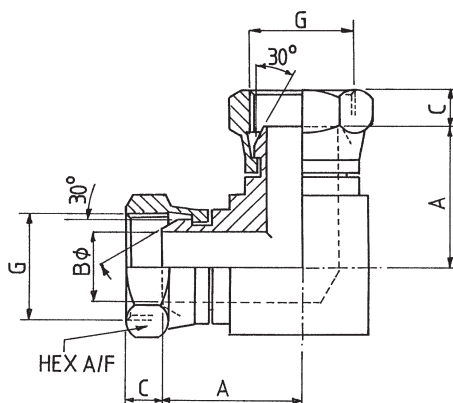

Part No.	BSP'P' Thread Size G	A	B	C	HEX
EBF-200-2	1/8"	25.4	3.5	4.1	14.3
EBF-200-4	1/4"	28.6	4.7	4.2	18.1
EBF-200-6	3/8"	31.5	8.1	4.6	22.2
EBF-200-8	1/2"	31.5	11.1	6.8	25.6
EBF-200-10	5/8"	37.3	14.2	10.1	28.6
EBF-200-12	3/4"	42.5	16.6	8.7	31.7
EBF-200-16	1"	49.5	22.2	10.1	38.1
EBF-200-20	1 1/4"	54.1	28.5	10.5	47.2
EBF-200-24	1 1/2"	59.8	33.3	12.2	56.4
EBF-200-32	2"	79.4	46.1	15.1	69.8

BSP'P' (CS) ALL SWIVEL FEMALE EQUAL TEE

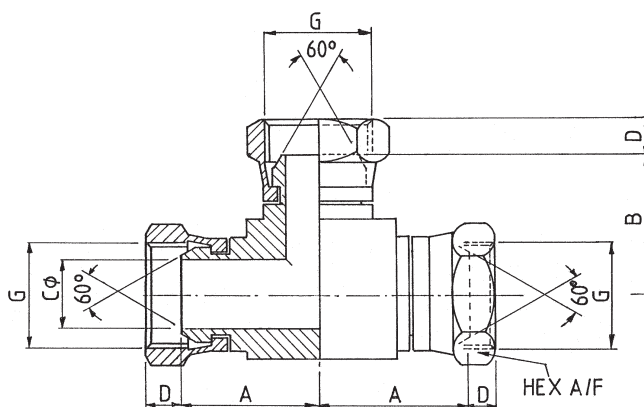

Part No.	BSP'P' Thread Size G	A	B	C	D	HEX
TF-200-2	1/8"	25.4	25.4	3.5	4.1	14.3
TF-200-4	1/4"	25.4	25.4	4.7	4.2	18.1
TF-200-6	3/8"	31.7	31.7	8.1	4.6	22.2
TF-200-8	1/2"	36.1	36.1	11.1	6.8	25.6
TF-200-10	5/8"	37.1	37.1	14.2	10.1	28.6
TF-200-12	3/4"	42.5	42.5	16.6	8.7	31.7
TF-200-16	1"	48.8	48.8	22.2	10.1	38.1
TF-200-20	1 1/4"	54.1	54.1	28.5	10.5	47.2
TF-200-24	1 1/2"	59.3	59.3	33.3	12.2	56.4
TF-200-32	2"	79.4	79.4	46.1	15.1	69.8

BSP'P' (CS) ALL SWIVEL FEMALE EQUAL CROSS

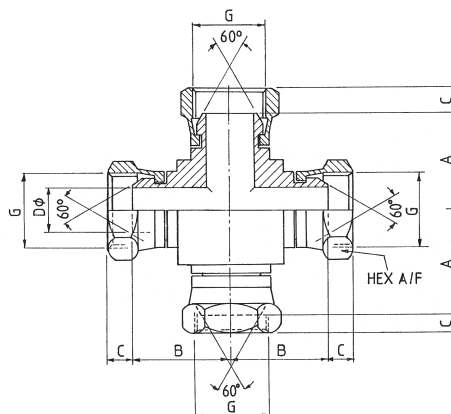

Part No.	BSP'P' Thread Size G	A	B	C	D	HEX
CRF-200-2	1/8"	25.4	25.4	4.1	3.5	14.3
CRF-200-4	1/4"	25.4	25.4	4.2	4.7	18.1
CRF-200-6	3/8"	31.7	31.7	4.6	8.1	22.2
CRF-200-8	1/2"	36.1	36.1	6.8	11.1	25.6
CRF-200-10	5/8"	37.1	37.1	10.1	14.2	28.6
CRF-200-12	3/4"	42.5	42.5	8.7	16.6	31.7
CRF-200-16	1"	48.8	48.8	10.1	22.2	38.1
CRF-200-20	1 1/4"	54.1	54.1	10.5	28.5	47.2
CRF-200-24	1 1/2"	59.3	59.3	12.2	33.3	56.4
CRF-200-32	2"	79.4	79.4	15.1	46.1	69.8

BSP'P' (CS) SWIVEL FEMALE/SWIVEL FEMALE 90° SWEEP ELBOW

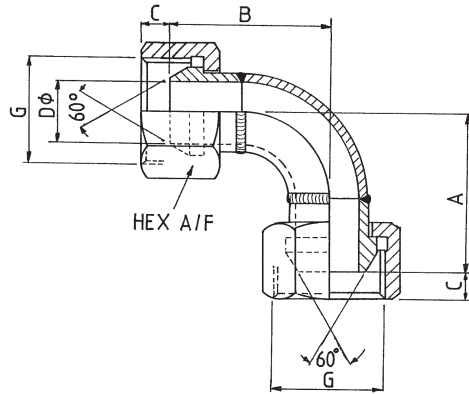

Part No.	BSP'P' Thread Size G	A	B	C	D	HEX
ESF-200-2	1/8"	31.1	31.1	4.1	3.5	14.3
ESF-200-4	1/4"	31.7	31.7	4.2	4.7	18.1
ESF-200-6	3/8"	39.6	39.6	4.6	8.1	22.2
ESF-200-8	1/2"	44.2	44.2	6.8	11.1	25.6
ESF-200-10	5/8"	49.4	49.4	10.1	14.2	28.6
ESF-200-12	3/4"	58.8	58.8	8.7	16.6	31.7
ESF-200-16	1"	56.6	56.6	10.1	22.2	38.1
ESF-200-20	1 1/4"	65.1	65.1	10.5	28.5	47.2
ESF-200-24	1 1/2"	82.1	82.1	12.2	33.3	56.4
ESF-200-32	2"	96.1	96.1	15.1	46.1	69.8

BSP'P' (CS) MALE/SWIVEL FEMALE 90° SWEEP ELBOW

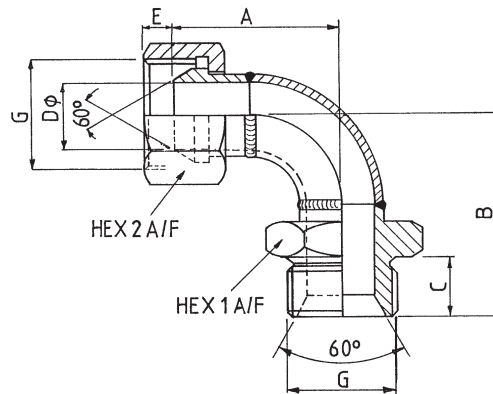

Part No.	BSP'P' Thread Size G	A	B	C	D	E	HEX 1	HEX 2
ESSN-200-2	1/8"	31.1	33.7	8	3.5	4.1	19.1	14.3
ESSN-200-4	1/4"	31.7	36.7	11	4.7	4.2	19.1	18.1
ESSN-200-6	3/8"	39.6	44.4	12	8.1	4.6	22.2	22.2
ESSN-200-8	1/2"	44.2	53.4	14	11.1	6.8	28.6	25.6
ESSN-200-10	5/8"	49.4	58.5	16	14.2	10.1	30.1	28.6
ESSN-200-12	3/4"	58.8	65.5	16	16.6	8.7	31.7	31.7
ESSN-200-16	1"	56.6	64.1	19	22.2	10.1	41.3	38.1
ESSN-200-20	1 1/4"	65.1	76.2	20	28.5	10.5	50.8	47.2
ESSN-200-24	1 1/2"	82.1	90.3	22	33.3	12.2	56.4	56.4
ESSN-200-32	2"	96.1	109.2	25	46.1	15.1	69.8	69.8

BSP'P' (CS) SWIVEL FEMALE/SWIVEL FEMALE 45° SWEEP ELBOW

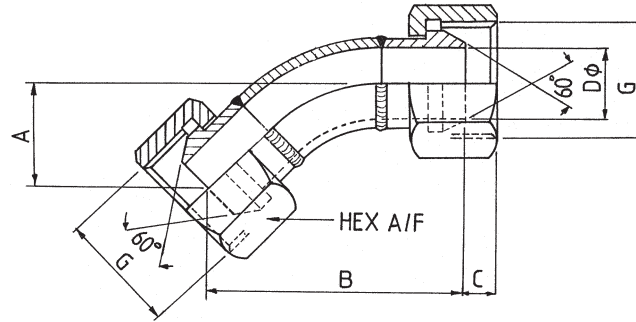

Part No.	BSP'P' Thread Size G	A	B	C	D	HEX
ESFF-200-2	1/8"	16.1	41.3	4.1	3.5	14.3
ESFF-200-4	1/4"	17.2	44.6	4.2	4.7	18.1
ESFF-200-6	3/8"	21.3	55.4	4.6	8.1	22.2
ESFF-200-8	1/2"	22.2	54.3	6.8	11.1	25.6
ESFF-200-10	5/8"	22.2	56.2	10.1	14.2	28.6
ESFF-200-12	3/4"	26.9	68.9	8.7	16.6	31.7
ESFF-200-16	1"	27.4	72.9	10.1	22.2	38.1
ESFF-200-20	1 1/4"	34.8	89.6	10.5	28.5	47.2
ESFF-200-24	1 1/2"	35.6	94.5	12.2	33.3	56.4
ESFF-200-32	2"	48.6	120.2	15.1	46.1	69.8

BSP'P' (CS) MALE/SWIVEL FEMALE 45° SWEEP ELBOW

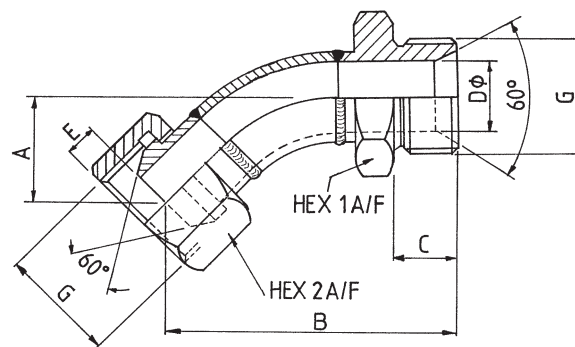

Part No.	BSP'P' Thread Size G	A	B	C	D	E	HEX 1	HEX 2
ESSNF-200-2	1/8"	17.7	45.6	8	3.5	4.1	19.1	14.3
ESSNF-200-4	1/4"	18.4	49.5	11	4.7	4.2	19.1	18.1
ESSNF-200-6	3/8"	25.6	57.9	12	8.1	4.6	22.2	22.2
ESSNF-200-8	1/2"	26.8	63.2	14	11.1	6.8	28.6	25.6
ESSNF-200-10	5/8"	31.2	65.4	16	14.2	10.1	30.1	28.6
ESSNF-200-12	3/4"	32.3	73.6	16	16.6	8.7	31.7	31.7
ESSNF-200-16	1"	28.6	76.8	19	22.2	10.1	41.3	38.1
ESSNF-200-20	1 1/4"	36.7	98.2	20	28.5	10.5	50.8	47.2
ESSNF-200-24	1 1/2"	42.5	100.3	22	33.3	12.2	56.4	56.4
ESSNF-200-32	2"	52.4	126.4	25	46.1	15.1	69.8	69.8

BSP'P' (CS) MALE/MALE POSITIONAL 90° ELBOW

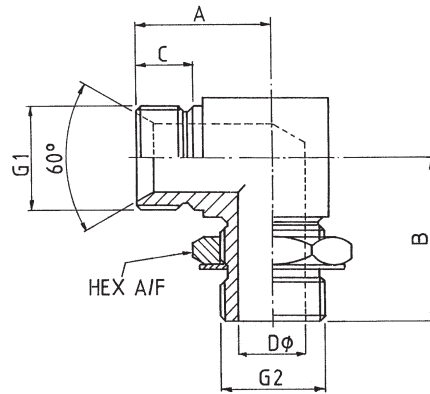

Part No.	BSP'P' Thread Size G1	BSP'P' Thread Size G2	A	B	C	D	HEX
EP-2BP-2	1/8"	1/8"	25.4	27.1	8.1	3.5	15.9
EP-2BP-4	1/4"	1/4"	25.4	31.7	11.1	5.1	19.1
EP-2BP-6	3/8"	3/8"	28.5	39.7	12.1	8.1	22.2
EP-2BP-8	1/2"	1/2"	32.5	46.1	14.1	11.1	28.6
EP-2BP-10	5/8"	5/8"	36.5	52.1	16.1	14.3	30.5
EP-2BP-12	3/4"	3/4"	41.3	54.1	16.1	16.6	35.1
EP-2BP-16	1"	1"	44.5	56.3	19.1	22.2	44.4
EP-2BP-20	1 1/4"	1 1/4"	50.8	65.7	20.1	28.6	50.8
EP-2BP-24	1 1/2"	1 1/2"	59.1	75.1	22.1	33.3	63.5
EP-2BP-32	2"	2"	77.5	85.1	25.1	46.1	69.8

BSP'P' (CS) MALE/MALE EQUAL ADAPTOR

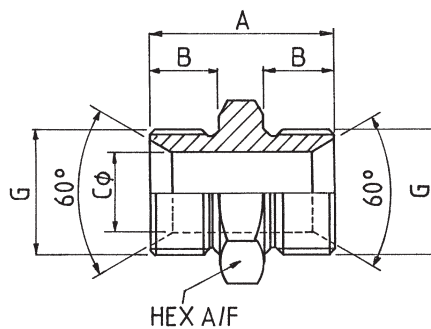

Part No.	BSP'P' Thread Size G	A	B	C	HEX
AE-200-2	1/8"	21.1	8.1	3.5	14.3
AE-200-4	1/4"	29.1	11.1	5.1	19.1
AE-200-6	3/8"	32.1	12.1	8.1	22.2
AE-200-8	1/2"	38.1	14.1	11.1	28.6
AE-200-10	5/8"	44.1	16.1	14.3	30.1
AE-200-12	3/4"	44.1	16.1	16.6	31.7
AE-200-16	1"	50.1	19.1	22.2	41.3
AE-200-20	1 1/4"	54.1	20.1	28.6	50.8
AE-200-24	1 1/2"	58.1	22.1	33.3	56.4
AE-200-32	2"	68.1	25.1	46.1	69.8

BSP'P' (CS) MALE/MALE/BULKHEAD WITH HEX BACKNUT

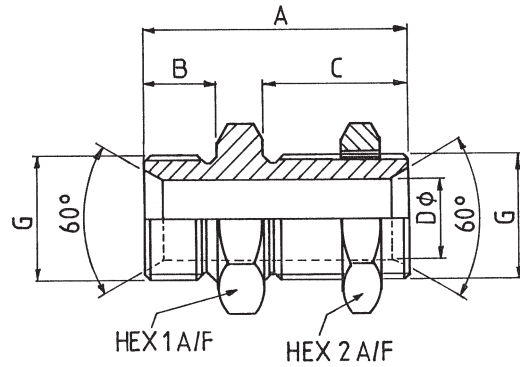

Part No.	BSP'P' Thread Size G	A	B	C	D	HEX 1	HEX 2
BUC-200-2	1/8"	41.1	8.1	28.1	3.5	14.3	15.9
BUC-200-4	1/4"	46.1	11.1	28.1	5.1	19.1	19.1
BUC-200-6	3/8"	52.1	12.1	32.1	8.1	22.2	22.2
BUC-200-8	1/2"	59.1	14.1	35.1	11.1	28.6	28.6
BUC-200-10	5/8"	63.1	16.1	35.1	14.3	30.5	30.5
BUC-200-12	3/4"	66.1	16.1	38.1	16.6	31.7	35.1
BUC-200-16	1"	72.1	19.1	41.1	22.2	41.3	44.4
BUC-200-20	1 1/4"	78.1	20.1	44.1	28.6	50.8	50.8
BUC-200-24	1 1/2"	84.1	22.1	48.1	33.3	56.4	63.5
BUC-200-32	2"	91.1	25.1	48.1	46.1	69.8	69.8

BSP'P' (OR) HEX PLUG

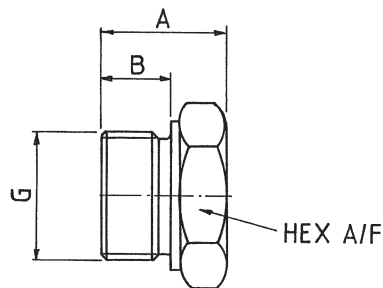

Part No.	BSP'P' Thread Size G	A	B	HEX
PO-2BP-2	1/8"	17.5	10.1	14.3
PO-2BP-4	1/4"	19.5	11.1	19.1
PO-2BP-6	3/8"	23.1	12.1	22.2
PO-2BP-8	1/2"	28.1	15.1	28.6
PO-2BP-10	5/8"	31.3	16.3	30.1
PO-2BP-12	3/4"	31.3	16.3	31.7
PO-2BP-16	1"	34.1	19.1	41.3
PO-2BP-20	1 1/4"	38.1	21.4	50.8
PO-2BP-24	1 1/2"	39.3	22.5	56.4
PO-2BP-32	2"	46.1	25.1	69.8

BSP'P' (CS) HEX PLUG

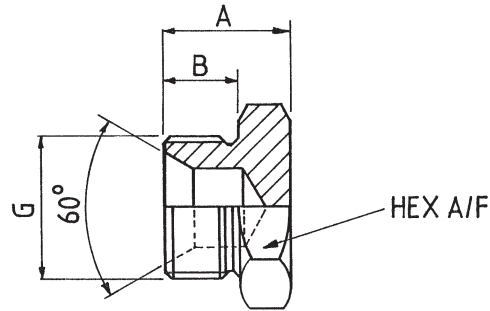

Part No.	BSP'P' Thread Size G	A	B	HEX
PC-2BP-2	1/8"	13.1	8.1	14.3
PC-2BP-4	1/4"	18.1	11.1	19.1
PC-2BP-6	3/8"	20.1	12.1	22.2
PC-2BP-8	1/2"	24.1	14.1	28.6
PC-2BP-10	5/8"	28.1	16.1	30.1
PC-2BP-12	3/4"	28.1	16.1	31.7
PC-2BP-16	1"	31.1	19.1	41.3
PC-2BP-20	1 1/4"	34.1	20.1	50.8
PC-2BP-24	1 1/2"	36.1	20.1	56.4
PC-2BP-32	2"	43.1	25.1	69.8

BSP'P' (CS) SWIVEL FEMALE/SWIVEL FEMALE ADAPTOR

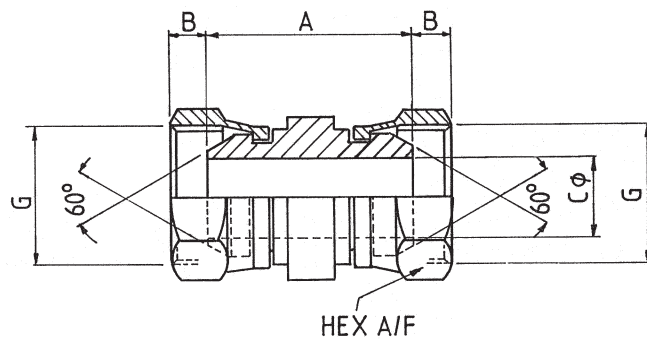

Part No.	BSP'P' Thread Size G	A	B	C	HEX
FFA-200-2	1/8"	23.1	4.1	3.5	14.3
FFA-200-4	1/4"	25.6	4.2	4.7	18.1
FFA-200-6	3/8"	31.2	4.6	8.1	22.2
FFA-200-8	1/2"	29.7	6.8	11.1	25.6
FFA-200-10	5/8"	36.3	10.1	14.2	28.6
FFA-200-12	3/4"	36.3	8.7	16.6	31.7
FFA-200-16	1"	40.8	10.1	22.2	38.1
FFA-200-20	1 1/4"	39.6	10.5	28.5	47.2
FFA-200-24	1 1/2"	53.1	12.2	33.3	56.4
FFA-200-32	2"	57.1	15.1	46.1	69.8

BSP'P' (CS) SWIVEL FEMALE CAP

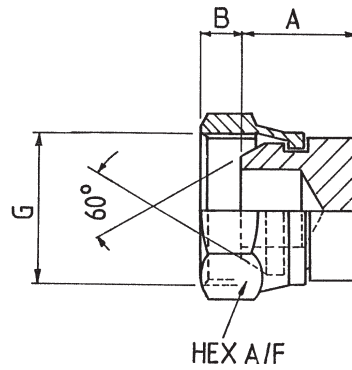

Part No.	BSP'P' Thread Size G	A	B	HEX
CC-200-2	1/8"	14.8	4.1	14.3
CC-200-4	1/4"	17.8	4.2	18.1
CC-200-6	3/8"	20.6	4.6	22.2
CC-200-8	1/2"	21.4	6.8	25.6
CC-200-10	5/8"	20.6	10.1	28.6
CC-200-12	3/4"	25.8	8.7	31.7
CC-200-16	1"	30.9	10.1	38.1
CC-200-20	1 1/4"	30.9	10.5	47.2
CC-200-24	1 1/2"	36.1	12.2	56.4
CC-200-32	2"	41.3	15.1	69.8

BSP'P' (OR) MALE/MALE EQUAL ADAPTOR

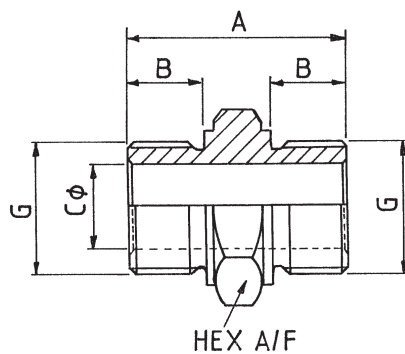

Part No.	BSP'P' Thread Size G	A	B	C	HEX
AEO-200-2	1/8"	23.8	7.4	3.5	14.3
AEO-200-4	1/4"	32.1	11.1	5.1	19.1
AEO-200-6	3/8"	38.1	12.1	8.1	22.2
AEO-200-8	1/2"	46.1	15.1	11.1	28.6
AEO-200-10	5/8"	50.6	16.1	14.3	30.1
AEO-200-12	3/4"	50.7	16.1	15.9	31.7
AEO-200-16	1"	56.1	19.1	22.2	41.3
AEO-200-20	1 1/4"	61.8	21.1	28.6	50.8
AEO-200-24	1 1/2"	65.1	22.1	33.3	56.4
AEO-200-32	2"	75.5	25.1	46.1	69.8

BSP'P' FIXED FEMALE HEX SOCKET

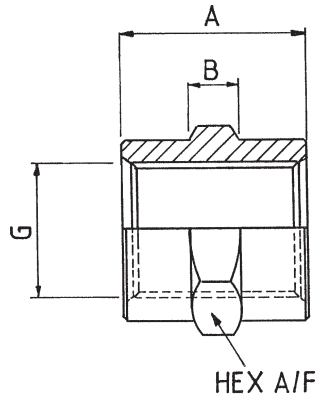

Part No.	BSP'P' Thread Size G	A	B	HEX
S-200-2	1/8"	19.1	6.4	15.9
S-200-4	1/4"	29.2	6.4	19.1
S-200-6	3/8"	30.7	6.4	22.2
S-200-8	1/2"	38.1	8.4	28.6
S-200-10	5/8"	39.4	10.1	30.1
S-200-12	3/4"	39.4	10.1	35.1
S-200-16	1"	48.5	10.1	41.3
S-200-20	1 1/4"	50.1	12.7	50.8
S-200-24	1 1/2"	50.1	14.3	60.3
S-200-32	2"	54.1	17.5	73.3

BSP'P' (CS) MALE/BSPP FIXED FEMALE HOSE BUSH

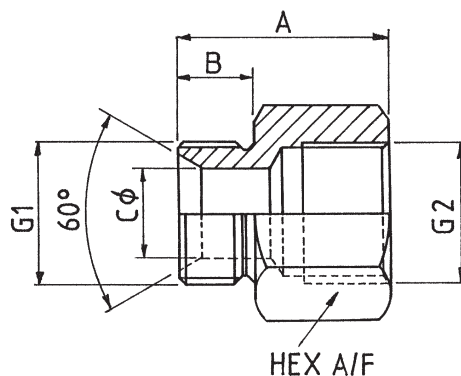

Part No.	BSP'P' Thread Size G1	BSP'P' Thread Size G2	A	B	C	HEX
HB-2BP-2	1/8"	1/8"	24.1	8.1	3.5	15.9
HB-2BP-2-4	1/8"	1/4"	27.1	8.1	3.5	19.1
HB-2BP-4	1/4"	1/4"	31.1	11.1	4.7	19.1
HB-2BP-4-2	1/4"	1/8"	27.1	11.1	4.7	19.1
HB-2BP-4-6	1/4"	3/8"	33.1	11.1	4.7	22.2
HB-2BP-6	3/8"	3/8"	34.1	12.1	8.1	22.2
HB-2BP-6-4	3/8"	1/4"	32.1	12.1	8.1	22.2
HB-2BP-6-8	3/8"	1/2"	37.1	12.1	8.1	28.6
HB-2BP-8	1/2"	1/2"	39.1	14.1	11.1	28.6
HB-2BP-8-6	1/2"	3/8"	36.1	14.1	11.1	28.6
HB-2BP-8-12	1/2"	3/4"	44.1	14.1	11.1	31.7
HB-2BP-10	5/8"	5/8"	44.1	16.1	14.3	31.7
HB-2BP-12	3/4"	3/4"	46.1	16.1	16.6	31.7
HB-2BP-12-8	3/4"	1/2"	41.1	16.1	16.6	31.7
HB-2BP-12-16	3/4"	1"	50.1	16.1	16.6	41.3
HB-2BP-16	1"	1"	51.1	19.1	22.2	41.3
HB-2BP-16-12	1"	3/4"	49.1	19.1	22.2	41.3
HB-2BP-16-20	1"	1 1/4"	54.1	19.1	22.2	50.8
HB-2BP-20	1 1/4"	1 1/4"	55.1	20.1	28.6	50.8
HB-2BP-20-16	1 1/4"	1"	52.1	20.1	28.6	50.8
HB-2BP-20-24	1 1/4"	1 1/2"	57.1	20.1	28.6	56.4
HB-2BP-24	1 1/2"	1 1/2"	57.1	22.1	33.3	56.4
HB-2BP-24-20	1 1/2"	1 1/4"	57.1	22.2	33.3	50.8
HB-2BP-24-32	1 1/2"	2"	67.1	22.2	33.3	69.8
HB-2BP-32	2"	2"	68.1	25.1	46.1	69.8
HB-2BP-32-24	2"	1 1/2"	59.1	25.1	46.1	69.8

BSP'P' (CS) MALE/NPT FIXED FEMALE HOSE BUSH

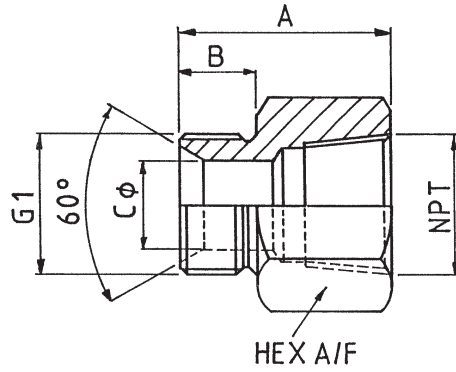

Part No.	BSP'P' Thread Size G1	NPT Thread Size NPT	A	B	C	HEX
HB-2NT-2	1/8"	1/8"	25.4	8.1	3.5	15.9
HB-2NT-4	1/4"	1/4"	33.2	11.1	4.7	19.1
HB-2NT-6	3/8"	3/8"	36.1	12.1	8.1	22.2
HB-2NT-8	1/2"	1/2"	41.1	14.1	11.1	28.6
HB-2NT-10-8	5/8"	1/2"	43.1	16.1	14.3	31.7
HB-2NT-12	3/4"	3/4"	46.1	16.1	16.6	34.9
HB-2NT-16	1"	1"	55.1	19.1	22.2	41.3
HB-2NT-20	1 1/4"	1 1/4"	55.1	20.1	28.6	50.8
HB-2NT-24	1 1/2"	1 1/2"	57.1	22.1	33.3	56.4
HB-2NT-32	2"	2"	68.1	25.1	46.1	69.8

BSP'P' (CS) MALE/BSP'T' FIXED FEMALE HOSE BUSH

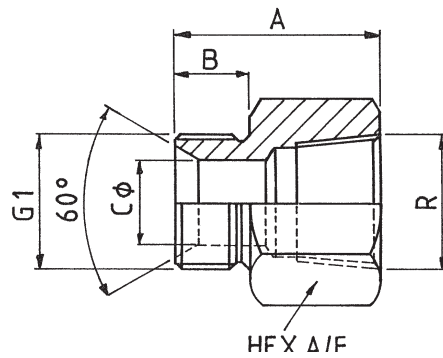

Part No.	BSP'P' Thread Size G1	BSP'T' Thread Size R	A	B	C	HEX
HB-2BT-2	1/8"	1/8"	25.4	8.1	3.5	15.9
HB-2BT-4	1/4"	1/4"	33.2	11.1	4.7	19.1
HB-2BT-6	3/8"	3/8"	36.1	12.1	8.1	22.2
HB-2BT-8	1/2"	1/2"	41.1	14.1	11.1	28.6
HB-2BT-10-8	5/8"	1/2"	43.1	16.1	14.3	31.7
HB-2BT-12	3/4"	3/4"	46.1	16.1	16.6	34.9
HB-2BT-16	1"	1"	55.1	19.1	22.2	41.3
HB-2BT-20	1 1/4"	1 1/4"	55.1	20.1	28.6	50.8
HB-2BT-24	1 1/2"	1 1/2"	57.1	22.1	33.3	56.4
HB-2BT-32	2"	2"	68.1	25.1	46.1	69.8

BSP'P' (CS) MALE x BSPP FIXED FEMALE GAUGE ADAPTOR

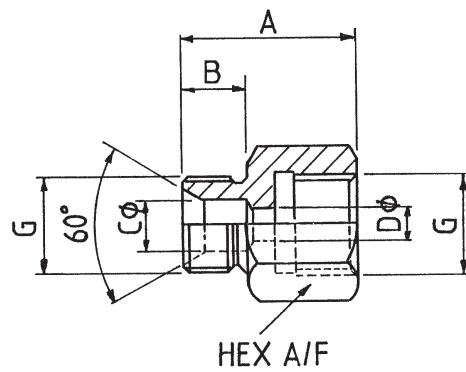

Part No.	BSP'P' Thread Size G	A	B	C	D	HEX
GAC-2BP-2	1/8"	21.7	8.1	3.5	4.4	15.9
GAC-2BP-4	1/4"	28.6	11.1	4.7	5.5	19.1
GAC-2BP-6	3/8"	32.3	12.1	6.1	6.1	22.2
GAC-2BP-8	1/2"	38.1	14.1	11.1	6.5	28.6

BSP'P' (CS) MALE/NPT MALE ADAPTOR

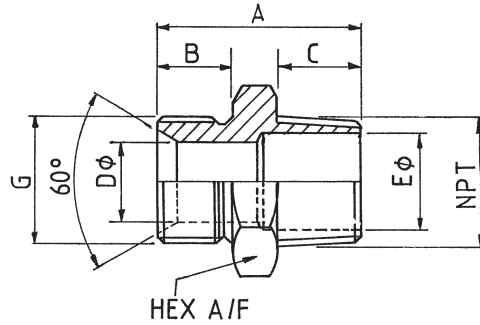

Part No.	BSP'P' Thread Size G	NPT Thread Size NPT	A	B	C	D	E	HEX
ACT-2NT-2	1/8"	1/8"	23.1	8.1	10.1	3.5	5.5	14.3
ACT-2NT-2-4	1/8"	1/4"	26.1	8.1	13.1	3.5	7.5	15.9
ACT-2NT-4	1/4"	1/4"	31.1	11.1	13.1	4.7	7.5	19.1
ACT-2NT-4-2	1/4"	1/8"	28.1	11.1	10.1	4.7	4.7	19.1
ACT-2NT-4-6	1/4"	3/8"	32.1	11.1	14.1	4.7	10.3	19.1
ACT-2NT-4-8	1/4"	1/2"	35.1	11.1	17.1	4.7	13.5	22.2
ACT-2NT-6	3/8"	3/8"	33.1	12.1	13.1	8.1	10.7	22.2
ACT-2NT-6-2	3/8"	1/8"	30.1	12.1	10.1	8.1	4.7	22.2
ACT-2NT-6-4	3/8"	1/4"	32.7	12.1	12.7	7.5	7.5	22.2
ACT-2NT-6-8	3/8"	1/2"	35.7	12.1	15.9	8.1	13.5	22.2
ACT-2NT-8	1/2"	1/2"	40.1	14.1	16.1	11.1	13.5	28.6
ACT-2NT-8-4	1/2"	1/4"	36.7	14.1	12.7	11.1	7.5	28.6
ACT-2NT-8-6	1/2"	3/8"	37.1	14.1	13.1	11.1	11.1	28.6
ACT-2NT-8-12	1/2"	3/4"	42.1	14.1	18.1	11.1	19.1	28.6
ACT-2NT-8-16	1/2"	1"	48.2	14.1	22.2	11.1	23.8	34.9
ACT-2NT-10-8	5/8"	1/2"	44.1	16.1	16.1	13.5	13.5	30.1
ACT-2NT-12	3/4"	3/4"	47.1	16.1	19.1	16.6	18.6	31.7
ACT-2NT-12-8	3/4"	1/2"	45.1	16.1	17.1	16.6	13.5	31.7
ACT-2NT-12-16	3/4"	1"	50.1	16.1	22.1	16.6	23.8	34.9
ACT-2NT-12-20	3/4"	1 1/4"	52.8	16.1	22.2	16.6	31.7	44.4
ACT-2NT-16	1"	1"	53.2	19.1	22.2	22.2	23.8	41.3
ACT-2NT-16-8	1"	1/2"	47.1	19.1	16.1	22.2	13.5	41.3
ACT-2NT-16-12	1"	3/4"	51.1	19.1	20.1	20.6	19.1	41.3
ACT-2NT-16-20	1"	1 1/4"	53.5	19.1	22.2	20.6	31.7	44.4
ACT-2NT-16-24	1"	1 1/2"	58.1	19.1	24.1	20.6	38.1	50.8
ACT-2NT-20	1 1/4"	1 1/4"	58.1	20.1	24.1	28.6	31.7	50.8
ACT-2NT-20-12	1 1/4"	3/4"	53.1	20.1	19.1	28.6	19.1	50.8
ACT-2NT-20-16	1 1/4"	1"	56.1	20.1	22.1	28.6	24.2	50.8
ACT-2NT-20-24	1 1/4"	1 1/2"	58.1	20.1	24.1	28.6	38.1	50.8
ACT-2NT-20-32	1 1/4"	2"	61.1	20.1	27.1	28.6	49.2	63.5
ACT-2NT-24	1 1/2"	1 1/2"	60.1	22.1	24.1	33.3	38.1	56.4
ACT-2NT-24-16	1 1/2"	1"	59.1	22.1	23.1	33.3	23.8	56.4
ACT-2NT-24-20	1 1/2"	1 1/4"	60.1	22.1	24.1	33.3	31.7	56.4
ACT-2NT-24-32	1 1/2"	2"	65.1	22.1	27.1	33.3	49.2	63.5
ACT-2NT-32	2"	2"	70.1	25.1	27.1	46.1	46.1	69.8
ACT-2NT-32-20	2"	1 1/4"	67.1	25.1	24.1	46.1	31.7	69.8
ACT-2NT-32-24	2"	1 1/2"	67.1	25.1	24.1	46.1	38.1	69.8

BSP'P' (CS) MALE/BSP'T' MALE ADAPTOR

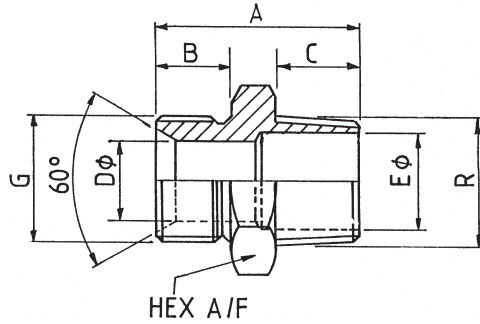

Part No.	BSP'P' Thread Size G	BSP'T' Thread Size R	A	B	C	D	E	HEX
ACT-2BT-2	1/8"	1/8"	23.1	8.1	10.1	3.5	5.5	14.3
ACT-2BT-2-4	1/8"	1/4"	26.1	8.1	13.1	3.5	7.5	15.9
ACT-2BT-4	1/4"	1/4"	31.1	11.1	13.1	4.7	7.5	19.1
ACT-2BT-4-2	1/4"	1/8"	28.1	11.1	10.1	4.7	4.7	19.1
ACT-2BT-4-6	1/4"	3/8"	32.1	11.1	14.1	4.7	10.3	19.1
ACT-2BT-4-8	1/4"	1/2"	35.1	11.1	17.1	4.7	13.5	22.2
ACT-2BT-6	3/8"	3/8"	33.1	12.1	13.1	8.1	10.7	22.2
ACT-2BT-6-2	3/8"	1/8"	30.1	12.1	10.1	8.1	4.7	22.2
ACT-2BT-6-4	3/8"	1/4"	32.7	12.1	12.7	7.5	7.5	22.2
ACT-2BT-6-8	3/8"	1/2"	35.7	12.1	15.9	8.1	13.5	22.2
ACT-2BT-8	1/2"	1/2"	40.1	14.1	16.1	11.1	13.5	28.6
ACT-2BT-8-4	1/2"	1/4"	36.7	14.1	12.7	11.1	7.5	28.6
ACT-2BT-8-6	1/2"	3/8"	37.1	14.1	13.1	11.1	11.1	28.6
ACT-2BT-8-12	1/2"	3/4"	42.1	14.1	18.1	11.1	19.1	28.6
ACT-2BT-8-16	1/2"	1"	48.2	14.1	22.2	11.1	23.8	34.9
ACT-2BT-10-8	5/8"	1/2"	44.1	16.1	16.1	13.5	13.5	30.1
ACT-2BT-12	3/4"	3/4"	47.1	16.1	19.1	16.6	18.6	31.7
ACT-2BT-12-8	3/4"	1/2"	45.1	16.1	17.1	16.6	13.5	31.7
ACT-2BT-12-16	3/4"	1"	50.1	16.1	22.1	16.6	23.8	34.9
ACT-2BT-12-20	3/4"	1 1/4"	52.8	16.1	22.2	16.6	31.7	44.4
ACT-2BT-16	1"	1"	53.2	19.1	22.2	22.2	23.8	41.3
ACT-2BT-16-8	1"	1/2"	47.1	19.1	16.1	22.2	13.5	41.3
ACT-2BT-16-12	1"	3/4"	51.1	19.1	20.1	20.6	19.1	41.3
ACT-2BT-16-20	1"	1 1/4"	53.5	19.1	22.2	20.6	31.7	44.4
ACT-2BT-16-24	1"	1 1/2"	58.1	19.1	24.1	20.6	38.1	50.8
ACT-2BT-20	1 1/4"	1 1/4"	58.1	20.1	24.1	28.6	31.7	50.8
ACT-2BT-20-12	1 1/4"	3/4"	53.1	20.1	19.1	28.6	19.1	50.8
ACT-2BT-20-16	1 1/4"	1"	56.1	20.1	22.1	28.6	24.2	50.8
ACT-2BT-20-24	1 1/4"	1 1/2"	58.1	20.1	24.1	28.6	38.1	50.8
ACT-2BT-20-32	1 1/4"	2"	61.1	20.1	27.1	28.6	49.2	63.5
ACT-2BT-24	1 1/2"	1 1/2"	60.1	22.1	24.1	33.3	38.1	56.4
ACT-2BT-24-16	1 1/2"	1"	59.1	22.1	23.1	33.3	23.8	56.4
ACT-2BT-24-20	1 1/2"	1 1/4"	60.1	22.1	24.1	33.3	31.7	56.4
ACT-2BT-24-32	1 1/2"	2"	65.1	22.1	27.1	33.3	49.2	63.5
ACT-2BT-32	2"	2"	70.1	25.1	27.1	46.1	46.1	69.8
ACT-2BT-32-20	2"	1 1/4"	67.1	25.1	24.1	46.1	31.7	69.8
ACT-2BT-32-24	2"	1 1/2"	67.1	25.1	24.1	46.1	38.1	69.8

BSP'P' (CS) MALE/BSP'P' (OR) MALE ADAPTOR

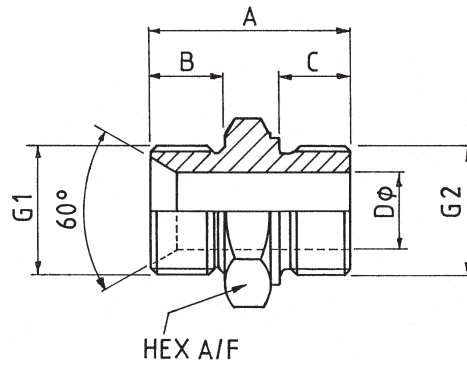

Part No.	BSP'P' Thread Size G1	BSP'P' Thread Size G2	A	B	C	D	HEX
ACO-2BP-2	1/8"	1/8"	25.5	8.1	7.4	3.5	14.3
ACO-2BP-4	1/4"	1/4"	31.1	11.1	11.1	5.1	19.1
ACO-2BP-6	3/8"	3/8"	34.1	12.1	12.1	8.1	22.2
ACO-2BP-8	1/2"	1/2"	42.1	14.1	15.1	11.1	28.6
ACO-2BP-10	5/8"	5/8"	47.1	16.1	16.1	14.3	30.1
ACO-2BP-12	3/4"	3/4"	47.1	16.1	16.1	15.9	31.7
ACO-2BP-16	1"	1"	53.1	19.1	19.1	22.2	41.3
ACO-2BP-20	1 1/4"	1 1/4"	58.1	20.1	21.1	28.6	50.8
ACO-2BP-24	1 1/2"	1 1/2"	61.1	22.1	22.1	33.3	56.4
ACO-2BP-32	2"	2"	71.1	25.1	25.1	46.1	69.8

BSP'P' (CS) MALE/SAE MALE ADAPTOR

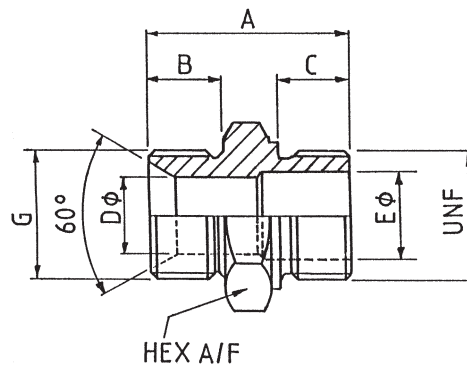

Part No.	BSP'P' Thread Size G	SAE Thread Size UNF	A	B	C	D	E	HEX
ACO-2SA-2	1/8"	5/16"-24	25.5	8.1	7.7	3.5	1.6	14.3
ACO-2SA-4	1/4"	7/16"-20	30.1	11.1	9.3	5.1	4.4	19.1
ACO-2SA-6	3/8"	9/16"-18	32.1	12.1	10.1	8.1	7.5	22.2
ACO-2SA-8	1/2"	3/4"-16	38.7	14.1	11.2	11.1	9.9	28.6
ACO-2SA-10	5/8"	7/8"-14	39.1	16.1	12.8	14.3	12.3	30.1
ACO-2SA-12	3/4"	1 1/16"-12	43.5	16.1	15.2	15.9	15.5	31.7
ACO-2SA-16	1"	1 5/16"-12	50.8	19.1	15.2	22.2	21.4	41.3
ACO-2SA-20	1 1/4"	1 5/8"-12	53.8	20.1	15.2	28.6	27.4	50.8
ACO-2SA-24	1 1/2"	1 7/8"-12	56.1	22.1	15.2	33.3	33.3	56.4
ACO-2SA-32	2"	2 1/2"-12	61.2	25.1	15.2	46.1	45.1	69.8

BSP'P' (CS) MALE/METRIC MALE ADAPTOR

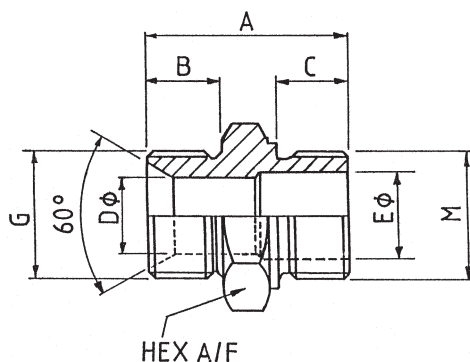

Part No.	BSP'P' Thread Size G	Metric Thread Size M	A	B	C	D	E	HEX
ACO-2M-2-10	1/8"	10 x 1	24.1	8.1	9.1	3.5	3.5	15.9
ACO-2M-4-14	1/4"	14 x 1.5	31.1	11.1	10.1	4.7	6.3	19.1
ACO-2M-6-16	3/8"	16 x 1.5	32.1	12.1	12.1	7.9	7.9	22.2
ACO-2M-8-18	1/2"	18 x 1.5	38.1	14.1	12.1	11.1	10.3	28.6
ACO-2M-10-22	5/8"	22 x 1.5	44.1	16.1	15.1	14.3	12.7	30.1
ACO-2M-12-27	3/4"	27 x 2	49.1	16.1	18.1	16.6	19.1	31.7
ACO-2M-16-33	1"	33 x 2	52.1	19.1	18.1	22.2	21.4	41.2
ACO-2M-20-42	1 1/4"	42 x 2	55.1	20.1	18.1	27.4	27.4	50.8
ACO-2M-24-50	1 1/2"	50 x 2	62.1	22.1	23.1	33.3	33.3	56.4
ACO-2M-32-60	2"	60 x 2	72.1	25.1	26.1	46.1	46.1	69.8

BSP'P' (CS) MALE/NPT MALE 90° ELBOW

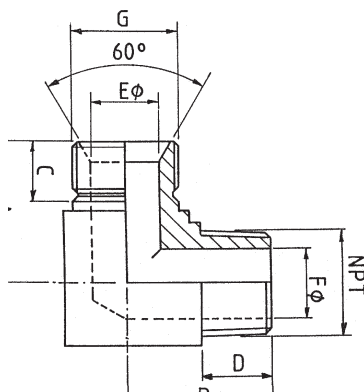

Part No.	BSP'P' Thread Size G	NPT Thread Size NPT	A	B	C	D	E	F
EBM-2NT-2	1/8"	1/8"	25.4	25.4	8.1	9.5	3.5	5.2
EBM-2NT-4	1/4"	1/4"	25.4	27.7	11.1	12.7	5.1	5.1
EBM-2NT-6	3/8"	3/8"	28.5	30.1	12.1	14.3	8.1	9.5
EBM-2NT-8	1/2"	1/2"	32.5	34.1	14.1	15.9	11.1	12.7
EBM-2NT-10-8	5/8"	1/2"	36.5	34.1	16.1	15.9	14.3	12.7
EBM-2NT-12	3/4"	3/4"	41.3	44.1	16.1	19.1	16.6	19.1
EBM-2NT-16	1"	1"	44.5	47.5	19.1	22.2	22.2	22.2
EBM-2NT-20	1 1/4"	1 1/4"	50.8	72.1	20.1	24.1	28.6	31.7
EBM-2NT-24	1 1/2"	1 1/2"	59.1	84.1	22.1	24.1	33.3	38.1
EBM-2NT-32	2"	2"	77.5	100.1	25.1	27.1	46.1	49.2

BSP'P' (CS) MALE/BSP'T' MALE 90° ELBOW

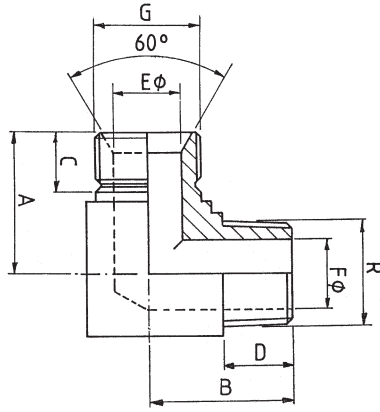

Part No.	BSP'P' Thread Size G	BSP'T' Thread Size R	A	B	C	D	E	F
EBM-2BT-2	1/8"	1/8"	25.4	25.4	8.1	9.5	3.5	5.2
EBM-2BT-4	1/4"	1/4"	25.4	27.7	11.1	12.7	5.1	5.1
EBM-2BT-6	3/8"	3/8"	28.5	30.1	12.1	14.3	8.1	9.5
EBM-2BT-8	1/2"	1/2"	32.5	34.1	14.1	15.9	11.1	12.7
EBM-2BT-10-8	5/8"	1/2"	36.5	34.1	16.1	15.9	14.3	12.7
EBM-2BT-12	3/4"	3/4"	41.3	44.1	16.1	19.1	16.6	19.1
EBM-2BT-16	1"	1"	44.5	47.5	19.1	22.2	22.2	22.2
EBM-2BT-20	1 1/4"	1 1/4"	50.8	72.1	20.1	24.1	28.6	31.7
EBM-2BT-24	1 1/2"	1 1/2"	59.1	84.1	22.1	24.1	33.3	38.1
EBM-2BT-32	2"	2"	77.5	100.1	25.1	27.1	46.1	49.2

BSP'P' (CS) MALE/NPT MALE 45° ELBOW

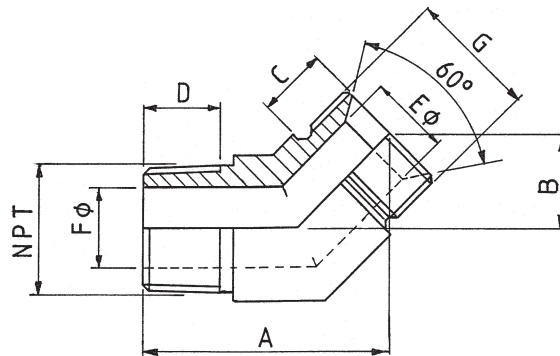

Part No.	BSP'P' Thread Size G	NPT Thread Size NPT	A	B	C	D	E	F
EBMF-2NT-2	1/8"	1/8"	33.6	14.9	8.1	9.5	3.5	5.2
EBMF-2NT-4	1/4"	1/4"	39.2	14.9	11.1	12.7	5.1	5.1
EBMF-2NT-6	3/8"	3/8"	42.7	17.3	12.1	14.3	8.1	9.5
EBMF-2NT-8	1/2"	1/2"	50.6	18.2	14.1	15.9	11.1	12.7
EBMF-2NT-10-8	5/8"	1/2"	50.6	19.9	16.1	15.9	14.3	12.7
EBMF-2NT-12	3/4"	3/4"	56.5	22.4	16.1	19.1	16.6	19.1
EBMF-2NT-16	1"	1"	61.8	24.9	19.1	22.2	22.2	22.2
EBMF-2NT-20	1 1/4"	1 1/4"	66.5	25.2	20.1	24.1	28.6	31.7
EBMF-2NT-24	1 1/2"	1 1/2"	68.6	27.9	22.1	24.1	33.3	38.1
EBMF-2NT-32	2"	2"	105.4	39.6	25.1	27.1	46.1	49.2

BSP'P' (CS) MALE/BSP'T' MALE 45° ELBOW

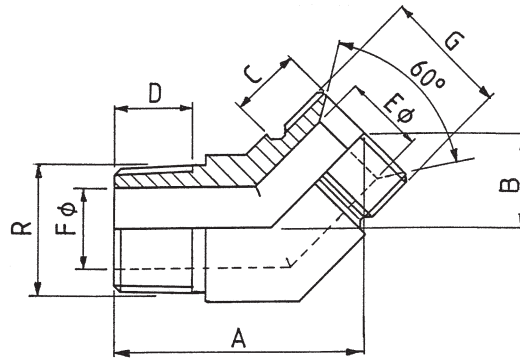

Part No.	BSP'P' Thread Size G	BSP'T' Thread Size R	A	B	C	D	E	F
EBMF-2BT-2	1/8"	1/8"	33.6	14.9	8.1	9.5	3.5	5.2
EBMF-2BT-4	1/4"	1/4"	39.2	14.9	11.1	12.7	5.1	5.1
EBMF-2BT-6	3/8"	3/8"	42.7	17.3	12.1	14.3	8.1	9.5
EBMF-2BT-8	1/2"	1/2"	50.6	18.2	14.1	15.9	11.1	12.7
EBMF-2BT-10-8	5/8"	1/2"	50.6	19.9	16.1	15.9	14.3	12.7
EBMF-2BT-12	3/4"	3/4"	56.5	22.4	16.1	19.1	16.6	19.1
EBMF-2BT-16	1"	1"	61.8	24.9	19.1	22.2	22.2	22.2
EBMF-2BT-20	1 1/4"	1 1/4"	66.5	25.2	20.1	24.1	28.6	31.7
EBMF-2BT-24	1 1/2"	1 1/2"	68.6	27.9	22.1	24.1	33.3	38.1
EBMF-2BT-32	2"	2"	105.4	39.6	25.1	27.1	46.1	49.2

BSPP (CS) SWIVEL FEMALE/NPT MALE SWEPT 90° ELBOW

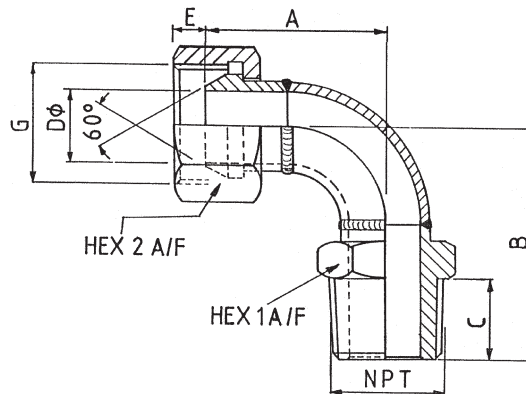

Part No.	BSP'P' Thread Size G	NPT Thread Size NPT	A	B	C	D	E	HEX 1	HEX 2
ESSN-2NT-2	1/8"	1/8"	31.1	36.2	9.5	3.5	4.1	12.7	14.3
ESSN-2NT-4	1/4"	1/4"	31.7	38.7	12.7	4.7	4.2	15.9	18.1
ESSN-2NT-6	3/8"	3/8"	39.6	46.4	12.7	8.1	4.6	18.1	22.2
ESSN-2NT-8	1/2"	1/2"	44.2	56.4	15.9	11.1	6.8	22.2	25.6
ESSN-2NT-10-8	5/8"	1/2"	49.4	62.5	15.9	14.2	10.1	22.2	28.6
ESSN-2NT-12	3/4"	3/4"	58.8	66.1	17.3	16.6	8.7	28.6	31.7
ESSN-2NT-16	1"	1"	56.6	67.1	20.5	22.2	10.1	34.9	38.1
ESSN-2NT-20	1 1/4"	1 1/4"	65.1	80.2	22.2	28.5	10.5	44.4	47.2
ESSN-2NT-24	1 1/2"	1 1/2"	82.1	92.1	22.2	33.3	12.2	50.8	56.4
ESSN-2NT-32	2"	2"	96.1	111.2	23.6	46.1	15.1	63.5	69.8

BSP'P' (CS) SWIVEL FEMALE/BSPT MALE SWEPT 90° ELBOW

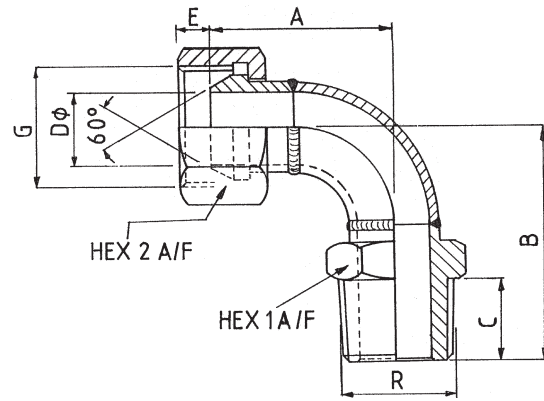

Part No.	BSP'P' Thread Size G	BSP'T' Thread Size R	A	B	C	D	E	HEX 1	HEX 2
ESSN-2BT-2	1/8"	1/8"	31.1	36.2	9.5	3.5	4.1	12.7	14.3
ESSN-2BT-4	1/4"	1/4"	31.7	38.7	12.7	4.7	4.2	15.9	18.1
ESSN-2BT-6	3/8"	3/8"	39.6	46.4	12.7	8.1	4.6	18.1	22.2
ESSN-2BT-8	1/2"	1/2"	44.2	56.4	15.9	11.1	6.8	22.2	25.6
ESSN-2BT-10-8	5/8"	1/2"	49.4	62.5	15.9	14.2	10.1	22.2	28.6
ESSN-2BT-12	3/4"	3/4"	58.8	66.1	17.3	16.6	8.7	28.6	31.7
ESSN-2BT-16	1"	1"	56.6	67.1	20.5	22.2	10.1	34.9	38.1
ESSN-2BT-20	1 1/4"	1 1/4"	65.1	80.2	22.2	28.5	10.5	44.4	47.2
ESSN-2BT-24	1 1/2"	1 1/2"	82.1	92.1	22.2	33.3	12.2	50.8	56.4
ESSN-2BT-32	2"	2"	96.1	111.2	23.6	46.1	15.1	63.5	69.8

BSP'P' (CS) SWIVEL FEMALE/NPT MALE 45° SWEPT ELBOW

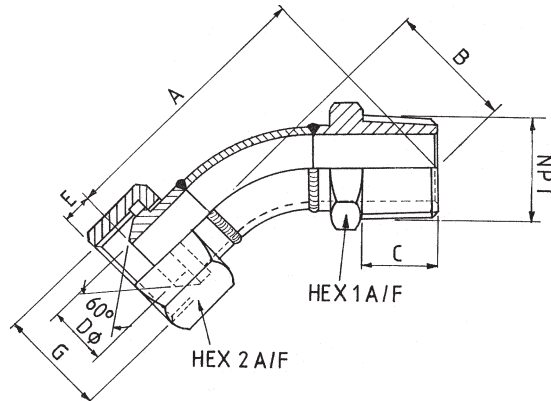

Part No.	BSP'P' Thread Size G	NPT Thread Size NPT	A	B	C	D	E	HEX 1	HEX 2
ESSNF-2NT-2	1/8"	1/8"	44.7	18.6	9.5	3.5	4.1	12.7	14.3
ESSNF-2NT-4	1/4"	1/4"	49.2	21.9	12.7	4.7	4.2	15.9	18.1
ESSNF-2NT-6	3/8"	3/8"	59.3	25.5	12.7	8.1	4.6	18.1	22.2
ESSNF-2NT-8	1/2"	1/2"	61.4	29.6	15.9	11.1	6.8	22.2	25.6
ESSNF-2NT-10-8	5/8"	1/2"	68.8	30.7	15.9	14.2	10.1	22.2	28.6
ESSNF-2NT-12	3/4"	3/4"	81.7	37.6	17.3	16.6	8.7	28.6	31.7
ESSNF-2NT-16	1"	1"	82.3	36.2	20.5	22.2	10.1	34.9	38.1
ESSNF-2NT-20	1 1/4"	1 1/4"	97.3	43.7	22.2	28.5	10.5	44.4	47.2
ESSNF-2NT-24	1 1/2"	1 1/2"	98.2	44.8	22.2	33.3	12.2	50.8	56.4
ESSNF-2NT-32	2"	2"	122.8	57.4	23.6	46.1	15.1	63.5	69.8

BSP'P' (CS) SWIVEL FEMALE/BSP'T' MALE 45° SWEPT ELBOW

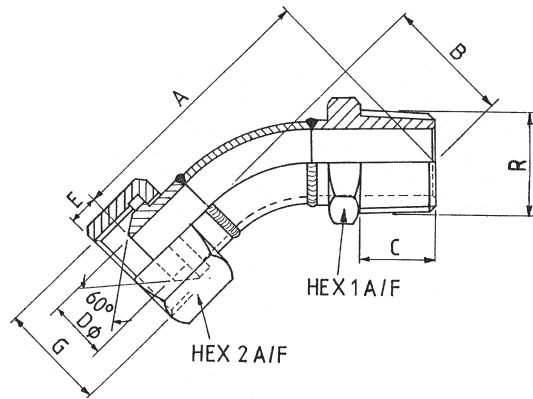

Part No.	BSP'P' Thread Size G	BSP'T' Thread Size R	A	B	C	D	E	HEX 1	HEX 2
ESSNF-2BT-2	1/8"	1/8"	44.7	18.6	9.5	3.5	4.1	12.7	14.3
ESSNF-2BT-4	1/4"	1/4"	49.2	21.9	12.7	4.7	4.2	15.9	18.1
ESSNF-2BT-6	3/8"	3/8"	59.3	25.5	12.7	8.1	4.6	18.1	22.2
ESSNF-2BT-8	1/2"	1/2"	61.4	29.6	15.9	11.1	6.8	22.2	25.6
ESSNF-2BT-10-8	5/8"	1/2"	68.8	30.7	15.9	14.2	10.1	22.2	28.6
ESSNF-2BT-12	3/4"	3/4"	81.7	37.6	17.3	16.6	8.7	28.6	31.7
ESSNF-2BT-16	1"	1"	82.3	36.2	20.5	22.2	10.1	34.9	38.1
ESSNF-2BT-20	1 1/4"	1 1/4"	97.3	43.7	22.2	28.5	10.5	44.4	47.2
ESSNF-2BT-24	1 1/2"	1 1/2"	98.2	44.8	22.2	33.3	12.2	50.8	56.4
ESSNF-2BT-32	2"	2"	122.8	57.4	23.6	46.1	15.1	63.5	69.8

BSP'P' (CS) MALE/MALE REDUCING ADAPTOR

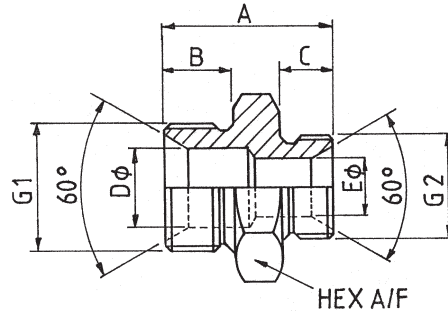

Part No.	BSP'P' Thread Size G1	BSP'P' Thread Size G2	A	B	C	D	E	HEX
AR-200-4-2	1/4"	1/8"	26.1	11.1	8.1	4.7	3.5	19.1
AR-200-6-2	3/8"	1/8"	28.1	12.1	8.1	7.9	3.5	22.2
AR-200-6-4	3/8"	1/4"	31.1	12.1	11.1	7.9	4.7	22.2
AR-200-8-4	1/2"	1/4"	35.1	14.1	11.1	11.1	4.7	28.6
AR-200-8-6	1/2"	3/8"	36.1	14.1	12.1	11.1	7.9	28.6
AR-200-10-8	5/8"	1/2"	42.1	16.1	14.1	14.2	11.1	30.1
AR-200-12-4	3/4"	1/4"	39.1	16.1	11.1	16.6	4.7	31.7
AR-200-12-6	3/4"	3/8"	40.1	16.1	12.1	16.6	7.9	31.7
AR-200-12-8	3/4"	1/2"	42.1	16.1	14.1	16.6	11.1	31.7
AR-200-12-10	3/4"	5/8"	44.1	16.1	16.1	16.6	14.2	31.7
AR-200-16-6	1"	3/8"	43.1	19.1	12.1	22.2	7.9	41.3
AR-200-16-8	1"	1/2"	45.1	19.1	14.1	22.2	11.1	41.3
AR-200-16-12	1"	3/4"	47.1	19.1	16.1	22.2	16.6	41.3
AR-200-20-12	1 1/4"	3/4"	50.1	20.1	16.1	28.6	16.6	50.8
AR-200-20-16	1 1/4"	1"	53.1	20.1	19.1	28.6	22.2	50.8
AR-200-24-12	1 1/2"	3/4"	52.1	22.1	16.1	33.3	16.6	56.4
AR-200-24-16	1 1/2"	1"	55.1	22.1	19.1	33.3	22.2	56.4
AR-200-24-20	1 1/2"	1 1/4"	56.1	22.1	20.1	33.3	28.6	56.4
AR-200-32-16	2"	1"	62.1	25.1	19.1	46.1	22.2	69.8
AR-200-32-20	2"	1 1/4"	63.1	25.1	20.1	46.1	28.6	69.8
AR-200-32-24	2"	1 1/2"	65.1	25.1	22.1	46.1	33.3	69.8

BSP'P' MALE/FIXED FEMALE REDUCING BUSH

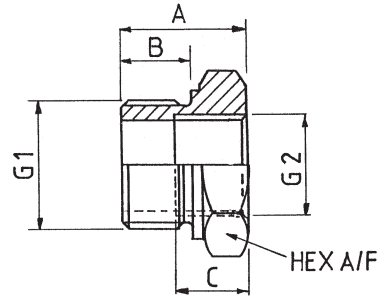

Part No.	BSP'P' Thread Size G1	BSP'P' Thread Size G2	A	B	C	HEX
B-200-4-2	1/4"	1/8"	30.1	11.1	10.1	19.1
B-200-6-2	3/8"	1/8"	20.1	12.1	10.1	22.2
B-200-6-4	3/8"	1/4"	30.1	12.1	11.1	22.2
B-200-8-4	1/2"	1/4"	23.1	15.1	11.1	28.6
B-200-8-6	1/2"	3/8"	35.1	15.1	12.1	28.6
B-200-12-4	3/4"	1/4"	26.1	15.1	11.1	31.7
B-200-12-6	3/4"	3/8"	26.1	15.1	12.1	31.7
B-200-12-8	3/4"	1/2"	41.1	15.1	15.1	31.7
B-200-16-8	1"	1/2"	29.1	18.1	15.1	41.3
B-200-16-12	1"	3/4"	46.1	18.1	16.1	41.3
B-200-20-12	1 1/4"	3/4"	32.1	20.1	16.1	50.8
B-200-20-16	1 1/4"	1"	50.1	20.1	18.1	50.8
B-200-24-16	1 1/2"	1"	34.1	22.1	18.1	56.4
B-200-24-20	1 1/2"	1 1/4"	55.1	22.1	21.1	56.4
B-200-32-20	2"	1 1/4"	39.1	25.1	21.1	69.8
B-200-32-24	2"	1 1/2"	39.1	25.1	21.1	69.8

BSP'P' (CS) MALE/NPT MALE BULKHEAD WITH HEX BACKNUT

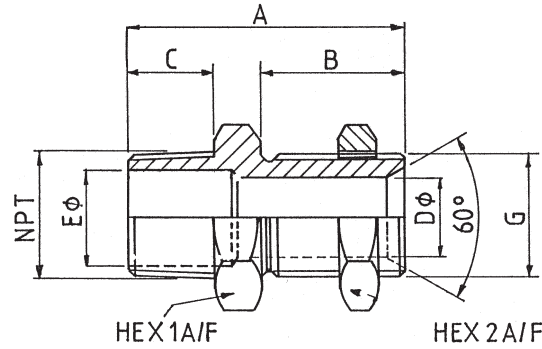

Part No.	BSP'P' Thread Size G	NPT Thread Size NPT	A	B	C	D	E	HEX 1	HEX 2
BUT-2NT-2	1/8"	1/8"	43.1	28.1	10.1	3.5	5.5	14.3	15.9
BUT-2NT-4	1/4"	1/4"	48.1	28.1	13.1	5.1	7.5	19.1	19.1
BUT-2NT-6	3/8"	3/8"	54.1	32.1	14.1	8.1	10.3	22.2	22.2
BUT-2NT-8	1/2"	1/2"	62.1	35.1	17.1	11.1	13.5	28.6	28.6
BUT-2NT-10-8	5/8"	1/2"	64.1	35.1	17.1	14.3	13.5	30.5	30.5
BUT-2NT-12	3/4"	3/4"	68.1	38.1	18.1	16.6	19.1	31.7	35.1
BUT-2NT-16	1"	1"	75.2	41.1	22.2	22.2	23.8	41.3	44.4
BUT-2NT-20	1 1/4"	1 1/4"	82.1	44.1	24.1	28.6	31.7	50.8	50.8
BUT-2NT-24	1 1/2"	1 1/2"	86.1	48.1	24.1	33.3	38.1	56.4	63.5
BUT-2NT-32	2"	2"	93.1	48.1	27.1	46.1	49.2	69.8	69.8

BSP'P' (CS) MALE BSP'T' MALE BULKHEAD WITH HEX BACKNUT

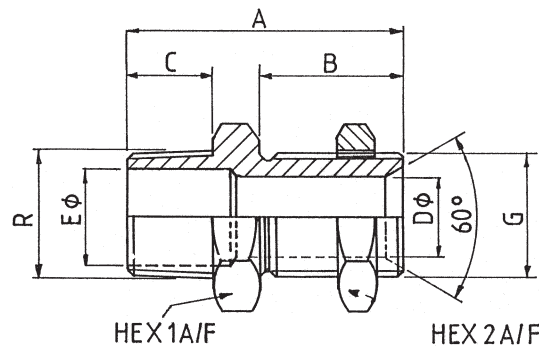

Part No.	BSP'P' Thread Size G	BSP'T' Thread Size R	A	B	C	D	E	HEX 1	HEX 2
BUT-2BT-2	1/8"	1/8"	43.1	28.1	10.1	3.5	5.5	14.3	15.9
BUT-2BT-4	1/4"	1/4"	48.1	28.1	13.1	5.1	7.5	19.1	19.1
BUT-2BT-6	3/8"	3/8"	54.1	32.1	14.1	8.1	10.3	22.2	22.2
BUT-2BT-8	1/2"	1/2"	62.1	35.1	17.1	11.1	13.5	28.6	28.6
BUT-2BT-10-8	5/8"	1/2"	64.1	35.1	17.1	14.3	13.5	30.5	30.5
BUT-2BT-12	3/4"	3/4"	68.1	38.1	18.1	16.6	19.1	31.7	35.1
BUT-2BT-16	1"	1"	75.2	41.1	22.2	22.2	23.8	41.3	44.4
BUT-2BT-20	1 1/4"	1 1/4"	82.1	44.1	24.1	28.6	31.7	50.8	50.8
BUT-2BT-24	1 1/2"	1 1/2"	86.1	48.1	24.1	33.3	38.1	56.4	63.5
BUT-2BT-32	2"	2"	93.1	48.1	27.1	46.1	49.2	69.8	69.8

BSP'P' (CS) SWIVEL FEMALE/BSPP (CS) MALE ADAPTOR

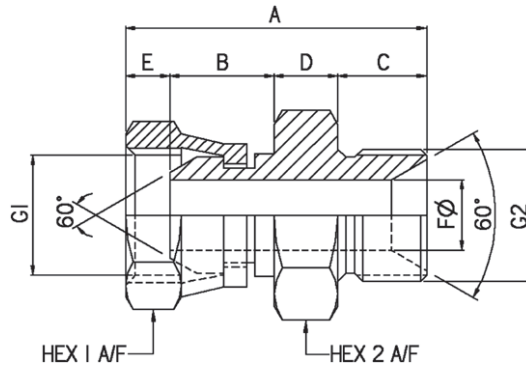

Part No.	BSP'P' Thread Size G1	BSP'P' Thread Size G2	A	B	C	D	E	F	HEX 1	HEX 2
FSC-2BP-2	1/8"	1/8"	30.2	13.1	8.1	3.5	4.1	3.5	19.1	14.3
FSC-2BP-2-4	1/8"	1/4"	35.2	13.1	11.1	3.5	4.1	4.7	19.1	14.3
FSC-2BP-4	1/4"	1/4"	37.2	15.1	11.1	4.7	4.2	4.7	19.1	18.1
FSC-2BP-4-2	1/4"	1/8"	31.2	15.1	8.1	4.7	4.2	3.5	19.1	18.1
FSC-2BP-4-6	1/4"	3/8"	38.6	14.4	12.1	4.7	4.2	8.1	19.1	18.1
FSC-2BP-6	3/8"	3/8"	41.7	16.5	12.1	8.1	4.6	8.1	22.2	22.2
FSC-2BP-6-4	3/8"	1/4"	39.8	16.5	11.1	8.1	4.6	4.7	22.2	22.2
FSC-2BP-6-8	3/8"	1/2"	45.4	16.5	14.1	8.1	4.6	11.1	22.2	22.2
FSC-2BP-8	1/2"	1/2"	47.3	16.5	14.1	11.1	6.8	11.1	28.6	25.6
FSC-2BP-8-4	1/2"	1/4"	41.9	16.5	11.1	11.1	6.8	4.7	28.6	25.6
FSC-2BP-8-6	1/2"	3/8"	42.9	16.5	12.1	11.1	6.8	8.1	28.6	25.6
FSC-2BP-8-10	1/2"	5/8"	49.2	16.5	16.1	11.1	6.8	14.2	28.6	25.6
FSC-2BP-8-12	1/2"	3/4"	49.2	16.5	16.1	11.1	6.8	16.6	28.6	25.6
FSC-2BP-10	5/8"	5/8"	57.7	16.1	16.1	14.2	10.1	14.2	30.1	28.6
FSC-2BP-10-8	5/8"	1/2"	49.3	16.1	14.1	14.2	10.1	11.1	30.1	28.6
FSC-2BP-10-12	5/8"	3/4"	53.5	16.1	16.1	14.2	10.1	16.6	30.1	28.6
FSC-2BP-12	3/4"	3/4"	52.6	17.5	16.1	16.6	8.7	16.6	31.7	31.7
FSC-2BP-12-8	3/4"	1/2"	50.8	17.5	14.1	16.6	8.7	11.1	31.7	31.7
FSC-2BP-12-10	3/4"	5/8"	54.2	17.5	16.1	16.6	8.7	14.2	31.7	31.7
FSC-2BP-12-16	3/4"	1"	57.2	17.5	19.1	16.6	8.7	22.2	31.7	31.7
FSC-2BP-16	1"	1"	62.2	21.2	19.1	22.2	10.1	22.2	41.3	38.1
FSC-2BP-16-12	1"	3/4"	59.3	21.2	16.1	22.2	10.1	16.6	41.3	38.1
FSC-2BP-16-20	1"	1 1/4"	65.3	21.2	20.1	22.2	10.1	28.5	41.3	38.1
FSC-2BP-20	1 1/4"	1 1/4"	66.4	21.5	20.1	28.5	10.5	28.5	50.8	47.2
FSC-2BP-20-16	1 1/4"	1"	74.9	21.5	19.1	28.5	10.5	22.2	50.8	47.2
FSC-2BP-20-24	1 1/4"	1 1/2"	78.9	21.5	22.1	28.5	10.5	33.3	50.8	47.2
FSC-2BP-24-24	1 1/2"	1 1/2"	87.8	26.4	22.1	33.3	12.2	33.3	56.4	56.4
FSC-2BP-24-20	1 1/2"	1 1/4"	85.8	26.4	20.1	33.3	12.2	28.5	56.4	56.4
FSC-2BP-24-32	1 1/2"	2"	95.4	26.4	25.1	33.3	12.2	46.1	56.4	56.4
FSC-2BP-32	2"	2"	103.1	30.1	25.1	46.1	15.1	46.1	69.8	69.8
FSC-2BP-32-24	2"	1 1/2"	100.2	30.1	22.1	46.1	15.1	33.3	69.8	69.8

BSP'P' (CS) SWIVEL FEMALE/NPT MALE ADAPTOR

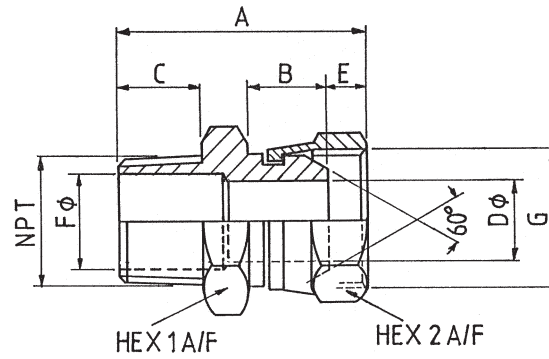

Part No.	BSP'P' Thread Size G	NPT Thread Size NPT	A	B	C	D	E	F	HEX 1	HEX 2
FST-2NT-2	1/8"	1/8"	30.5	13.1	10.1	3.5	4.1	5.5	12.7	14.3
FST-2NT-4	1/4"	1/4"	37.2	15.1	13.1	5.1	4.2	7.1	15.9	18.1
FST-2NT-6	3/8"	3/8"	43.6	16.5	14.1	7.2	4.6	10.3	18.1	22.2
FST-2NT-8	1/2"	1/2"	47.2	16.5	17.1	11.1	6.8	13.9	22.2	25.6
FST-2NT-10-8	5/8"	1/2"	51.5	16.5	17.1	12.7	10.1	13.9	22.2	28.6
FST-2NT-12	3/4"	3/4"	55.3	17.5	18.1	15.5	8.7	19.1	28.6	31.7
FST-2NT-16	1"	1"	63.3	21.2	22.2	19.8	10.1	23.8	34.9	38.1
FST-2NT-20	1 1/4"	1 1/4"	68.3	21.5	22.2	26.1	10.5	32.5	41.3	47.2
FST-2NT-24	1 1/2"	1 1/2"	80.5	26.4	24.1	31.7	12.2	38.1	50.8	56.4
FST-2NT-32	2"	1 1/2"	90.1	30.1	27.1	41.3	15.1	46.1	63.5	69.8

BSP'P' SWIVEL FEMALE/BSPT MALE ADAPTOR

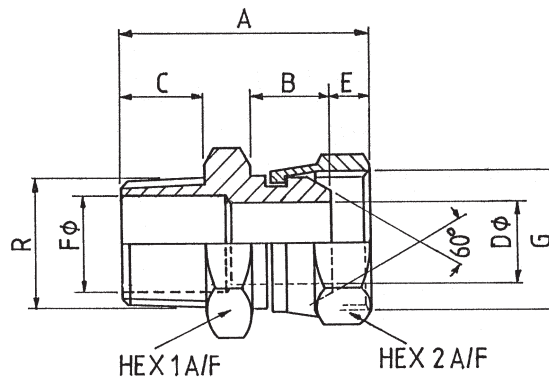

Part No.	BSP'P' Thread Size G	BSPT Thread Size R	A	B	C	D	E	F	HEX 1	HEX 2
FST-2BT-2	1/8"	1/8"	30.5	13.1	10.1	3.5	4.1	5.5	12.7	14.3
FST-2BT-4	1/4"	1/4"	37.2	15.1	13.1	5.1	4.2	7.1	15.9	18.1
FST-2BT-6	3/8"	3/8"	43.6	16.5	14.1	7.2	4.6	10.3	18.1	22.2
FST-2BT-8	1/2"	1/2"	47.2	16.5	17.1	11.1	6.8	13.9	22.2	25.6
FST-2BT-10-8	5/8"	1/2"	51.5	16.5	17.1	12.7	10.1	13.9	22.2	28.6
FST-2BT-12	3/4"	3/4"	55.3	17.5	18.1	15.5	8.7	19.1	28.6	31.7
FST-2BT-16	1"	1"	63.3	21.2	22.2	19.8	10.1	23.8	34.9	38.1
FST-2BT-20	1 1/4"	1 1/4"	68.3	21.5	22.2	26.1	10.5	32.5	41.3	47.2
FST-2BT-24	1 1/2"	1 1/2"	80.5	26.4	24.1	31.7	12.2	38.1	50.8	56.4
FST-2BT-32	2"	2"	90.1	30.1	27.1	41.3	15.1	46.1	63.5	69.8

BSP'P' (CS) SWIVEL FEMALE x BSPP (OR) MALE ADAPTOR

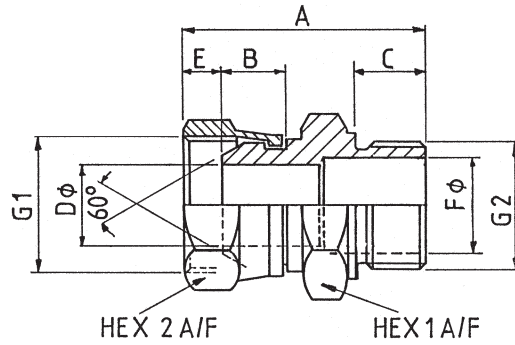

Part No.	BSP'P' Thread Size G1	BSP'P' Thread Size G2	A	B	C	D	E	F	HEX 1	HEX 2
FSO-2BP-2	1/8"	1/8"	31.1	13.1	7.4	3.5	4.1	3.5	14.3	14.3
FSO-2BP-4	1/4"	1/4"	38.7	15.1	11.1	5.1	4.2	5.1	19.1	18.1
FSO-2BP-6	3/8"	3/8"	43.1	16.5	12.1	7.2	4.6	7.2	22.2	22.2
FSO-2BP-8	1/2"	1/2"	50.8	16.5	15.1	11.1	6.8	11.1	28.6	25.6
FSO-2BP-10	5/8"	5/8"	57.1	16.5	16.1	12.7	10.1	12.7	30.1	28.6
FSO-2BP-12	3/4"	3/4"	57.1	17.5	16.1	15.5	8.7	15.5	31.7	31.7
FSO-2BP-16	1"	1"	64.7	21.2	19.1	19.8	10.1	19.8	41.3	38.1
FSO-2BP-20	1 1/4"	1 1/4"	69.5	21.5	21.1	26.1	10.5	26.1	50.8	47.2
FSO-2BP-24	1 1/2"	1 1/2"	77.1	26.4	22.1	31.7	12.2	31.7	56.4	56.4
FSO-2BP-32	2"	2"	91.1	30.1	25.1	41.3	15.1	41.3	69.8	69.8

BSP'P' (CS) SWIVEL FEMALE/SAE MALE ADAPTOR

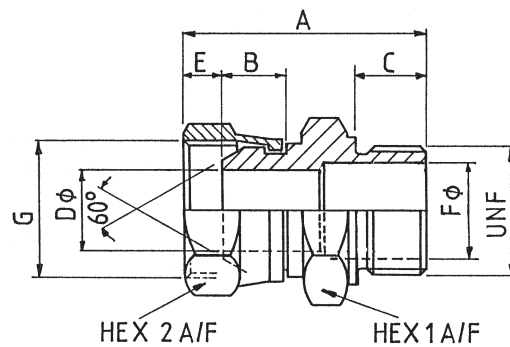

Part No.	BSP'P' Thread Size G	SAE Thread Size UNF	A	B	C	D	E	F	HEX 1	HEX 2
FSO-2SA-2	1/8"	5/16"-24	31.9	13.1	7.7	3.5	4.1	1.6	4.3	14.3
FSO-2SA-4	1/4"	7/16"-20	35.7	15.1	9.3	5.1	4.2	4.4	14.3	18.1
FSO-2SA-6	3/8"	9/16"-18	39.1	16.5	10.1	7.2	4.6	7.5	18.1	22.2
FSO-2SA-8	1/2"	3/4"-16	43.1	16.5	11.2	11.1	6.8	9.9	22.2	25.6
FSO-2SA-10	5/8"	7/8"-14	49.5	16.5	12.8	12.7	10.1	12.3	25.6	28.6
FSO-2SA-12	3/4"	1 1/16"-12	54.1	17.5	15.2	15.5	8.7	15.5	31.7	31.7
FSO-2SA-16	1"	1 5/16"-12	59.1	21.2	15.2	19.8	10.1	21.4	38.1	38.1
FSO-2SA-20	1 1/4"	1 5/8"-12	61.9	21.5	15.2	26.1	10.5	27.4	50.8	47.2
FSO-2SA-24	1 1/2"	1 7/8"-12	70.3	26.4	15.2	31.7	12.2	33.3	56.4	56.4
FSO-2SA-32	2"	2 1/2"-12	80.8	30.1	15.2	41.3	15.1	45.1	69.8	69.8

BSP'P' (CS) SWIVEL FEMALE/METRIC MALE ADAPTOR

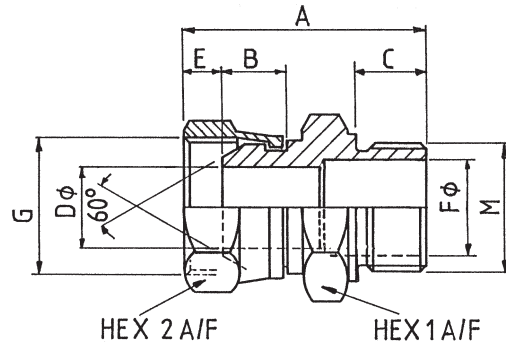

Part No.	BSP'P' Thread Size G	METRIC Thread Size M	A	B	C	D	E	F	HEX 1	HEX 2
FSO-2M-2-10	1/8"	10 x 1	31.1	13.1	9.1	3.5	4.1	3.5	15.9	14.3
FSO-2M-4-14	1/4"	14 x 1.5	38.7	15.1	10.1	5.1	4.2	6.3	19.1	18.1
FSO-2M-6-16	3/8"	16 x 1.5	43.1	16.5	12.1	7.2	4.6	7.9	22.2	22.2
FSO-2M-8-18	1/2"	18 x 1.5	50.8	16.5	12.1	11.1	6.8	10.3	28.6	25.6
FSO-2M-10-22	5/8"	22 x 1.5	57.1	16.5	15.1	12.7	10.1	12.7	30.1	28.6
FSO-2M-12-27	3/4"	27 x 2	57.1	17.5	18.1	15.5	8.7	19.1	31.7	31.7
FSO-2M-16-33	1"	33 x 2	64.7	21.2	18.1	19.8	10.1	21.4	41.2	38.1
FSO-2M-20-42	1 1/4"	42 x 2	69.5	21.5	18.1	26.1	10.5	27.4	50.8	47.2
FSO-2M-24-50	1 1/2"	50 x 2	77.1	26.4	23.1	31.7	12.2	33.3	56.4	56.4
FSO-2M-32-60	2"	60 x 2	91.1	30.1	26.1	41.3	15.1	46.1	69.8	69.8

BSP'P' (CS) BANJO

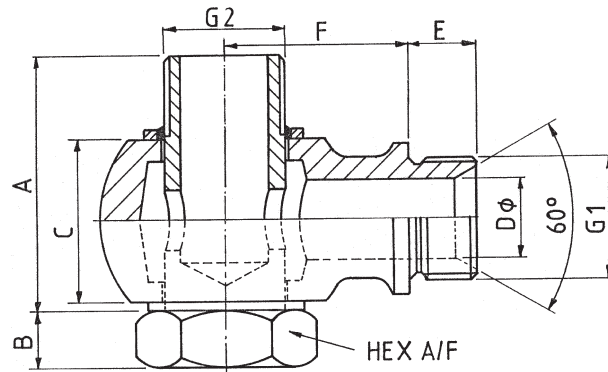

Part No.	BSP'P' Thread Size G1	BSP'P' Thread Size G2	A	B	C	D	E	F	HEX
BAC-2BP-2	1/8"	1/8"	30.1	6.1	20.1	3.5	8.1	18.1	14.3
BAC-2BP-4	1/4"	1/4"	34.1	7.1	24.1	4.7	11.1	22.1	18.3
BAC-2BP-6	3/8"	3/8"	40.1	8.1	28.6	8.1	12.1	25.4	23.4
BAC-2BP-8	1/2"	1/2"	48.7	12.1	34.7	11.1	14.1	30.1	27.1
BAC-2BP-10	5/8"	5/8"	54.2	15.1	38.6	14.3	16.1	34.9	30.1
BAC-2BP-12	3/4"	3/4"	56.7	16.1	40.7	16.6	16.1	40.1	31.7
BAC-2BP-16	1"	1"	67.7	20.1	48.7	22.2	19.1	50.1	41.3

BSP'P' (CS) SWIVEL FEMALE/NPT FIXED FEMALE ADAPTOR

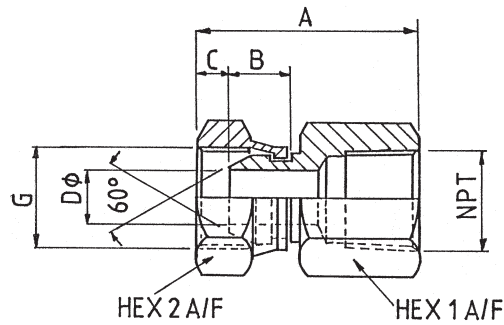

Part No.	BSP'P' Thread Size G	NPT Thread Size NPT	A	B	C	D	HEX 1	HEX 2
FSFF-2NT-2	1/8"	1/8"	34.5	13.1	4.1	3.5	15.9	14.3
FSFF-2NT-4	1/4"	1/4"	41.5	15.1	4.2	5.1	19.1	18.1
FSFF-2NT-6	3/8"	3/8"	45.1	16.5	4.6	7.2	22.2	22.2
FSFF-2NT-8	1/2"	1/2"	50.3	16.5	6.8	11.1	28.6	25.6
FSFF-2NT-10-8	5/8"	1/2"	53.5	16.5	10.1	12.7	31.7	28.6
FSFF-2NT-12	3/4"	3/4"	56.2	17.5	8.7	15.5	34.9	31.7
FSFF-2NT-16	1"	1"	67.2	21.2	10.1	19.8	41.3	38.1
FSFF-2NT-20	1 1/4"	1 1/4"	67.1	21.5	10.5	26.1	50.8	47.2
FSFF-2NT-24	1 1/2"	1 1/2"	73.6	26.4	12.2	31.7	56.4	56.4
FSFF-2NT-32	2"	2"	88.1	30.1	15.1	41.3	69.8	69.8

BSP'P' (CS) SWIVEL FEMALE/BSP'T' FIXED FEMALE ADAPTOR

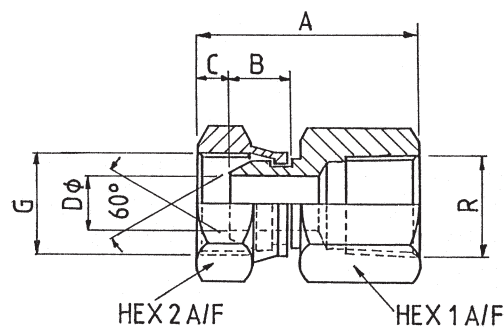

Part No.	BSP'P' Thread Size G	BSP'T' Thread Size R	A	B	C	D	HEX 1	HEX 2
FSFF-2BT-2	1/8"	1/8"	34.5	13.1	4.1	3.5	15.9	14.3
FSFF-2BT-4	1/4"	1/4"	41.5	15.1	4.2	5.1	19.1	18.1
FSFF-2BT-6	3/8"	3/8"	45.1	16.5	4.6	7.2	22.2	22.2
FSFF-2BT-8	1/2"	1/2"	50.3	16.5	6.8	11.1	28.6	25.6
FSFF-2BT-10-8	5/8"	1/2"	53.5	16.5	10.1	12.7	31.7	28.6
FSFF-2BT-12	3/4"	3/4"	56.2	17.5	8.7	15.5	34.9	31.7
FSFF-2BT-16	1"	1"	67.2	21.2	10.1	19.8	41.3	38.1
FSFF-2BT-20	1 1/4"	1 1/4"	67.1	21.5	10.5	26.1	50.8	47.2
FSFF-2BT-24	1 1/2"	1 1/2"	73.6	26.4	12.2	31.7	56.4	56.4
FSFF-2BT-32	2"	2"	88.1	30.1	15.1	41.3	69.8	69.8

BSPP (CS) SWIVEL FEMALE/BSPP FIXED FEMALE ADAPTOR

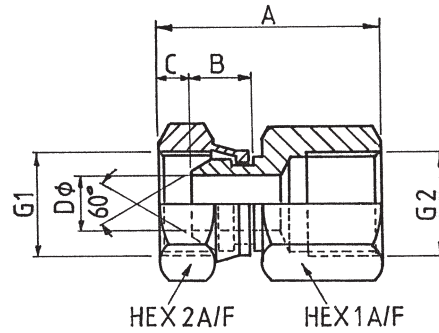

Part No.	BSP'P' Thread Size G1	BSPP Thread Size G2	A	B	C	D	HEX 1	HEX 2
FSFF-2BP-2	1/8"	1/8"	33.1	13.1	4.1	3.5	15.9	14.3
FSFF-2BP-4	1/4"	1/4"	39.3	15.1	4.2	5.1	19.1	18.1
FSFF-2BP-6	3/8"	3/8"	43.1	16.5	4.6	7.2	22.2	22.2
FSFF-2BP-8	1/2"	1/2"	48.3	16.5	6.8	11.1	28.6	25.6
FSFF-2BP-10	5/8"	5/8"	54.5	16.5	10.1	12.7	31.7	28.6
FSFF-2BP-12	3/4"	3/4"	56.2	17.5	8.7	15.5	31.7	31.7
FSFF-2BP-16	1"	1"	63.2	21.2	10.1	19.8	41.3	38.1
FSFF-2BP-20	1 1/4"	1 1/4"	67.1	21.5	10.5	26.1	50.8	47.2
FSFF-2BP-24	1 1/2"	1 1/2"	73.6	26.4	12.2	31.7	56.4	56.4
FSFF-2BP-32	2"	2"	88.1	30.1	15.1	41.3	69.8	69.8

BSP'P' (CS) SWIVEL FEMALE/SAE FIXED FEMALE ADAPTOR

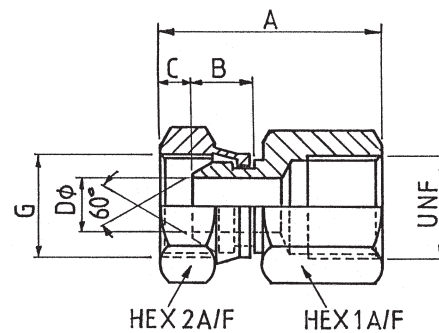

Part No.	BSP'P' Thread Size G	SAE Thread Size UNF	A	B	C	D	HEX 1	HEX 2
FSFF-2SA-2	1/8"	5/16"-24	33.1	13.1	4.1	3.5	15.9	14.3
FSFF-2SA-4	1/4"	7/16"-20	39.3	15.1	4.2	5.1	19.1	18.1
FSFF-2SA-6	3/8"	9/16"-18	43.1	16.5	4.6	7.2	22.2	22.2
FSFF-2SA-8	1/2"	3/4"-16	48.3	16.5	6.8	11.1	28.6	25.6
FSFF-2SA-10	5/8"	7/8"-14	54.5	16.5	10.1	12.7	31.7	28.6
FSFF-2SA-12	3/4"	1 1/16"-12	56.2	17.5	8.7	15.5	31.7	31.7
FSFF-2SA-16	1"	1 5/16"-12	63.2	21.2	10.1	19.8	41.3	38.1
FSFF-2SA-20	1 1/4"	1 5/8"-12	67.1	21.5	10.5	26.1	50.8	47.2
FSFF-2SA-24	1 1/2"	1 7/8"-12	73.6	26.4	12.2	31.7	56.4	56.4
FSFF-2SA-32	2"	2 1/2"-12	88.1	30.1	15.1	41.3	69.8	69.8

BSP'P' (CS) HEX MALE FOR WELDING

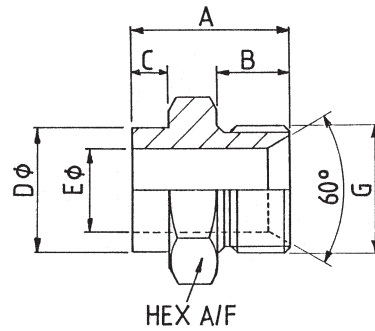

Part No.	BSP'P' Thread Size G	A	B	C	D	E	HEX
FMC-125-2	1/8"	22.1	8.1	7.1	12.7	3.5	14.3
FMC-125-4	1/4"	25.1	11.1	7.1	14.2	5.1	19.1
FMC-125-6	3/8"	30.1	12.1	10.1	16.2	8.1	22.2
FMC-125-8	1/2"	34.1	14.1	10.1	19.1	11.1	28.6
FMC-125-10	5/8"	37.6	16.1	10.2	17.3	14.3	30.1
FMC-125-12	3/4"	38.2	16.1	10.2	25.4	16.6	31.7
FMC-125-16	1"	41.3	19.1	10.2	31.7	22.2	41.3
FMC-125-20	1 1/4"	46.1	20.1	12.1	38.1	28.6	50.8
FMC-125-24	1 1/2"	51.2	22.1	15.2	44.4	33.3	56.4
FMC-125-32	2"	58.2	25.1	15.2	60.3	46.1	69.8

CONE SEAT NIPPLES FOR WELDING

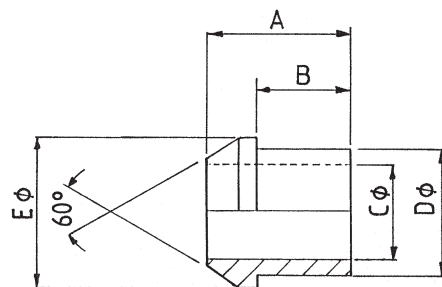

Part No.	A	B	C	D	E
CN-125-2	19.5	15.8	3.2	6.3	8.3
CN-125-4	23.8	17.3	4.7	8.9	11.3
CN-125-6	27.8	19.1	7.3	12.2	14.6
CN-125-8	30.5	22.2	10.1	14.9	18.4
CN-125-10	29.3	22.2	12.2	17.1	20.3
CN-125-12	31.7	22.2	15.4	20.1	23.9
CN-125-16	34.9	23.6	20.3	25.9	29.9
CN-125-20	34.9	23.6	25.4	33.8	38.1
CN-125-24	38.7	25.4	30.6	41.1	44.4
CN-125-32	39.6	25.4	44.4	52.1	56.5

BSP'P' (CS) HEX MALE FOR SOCKET WELD (OD) TUBE

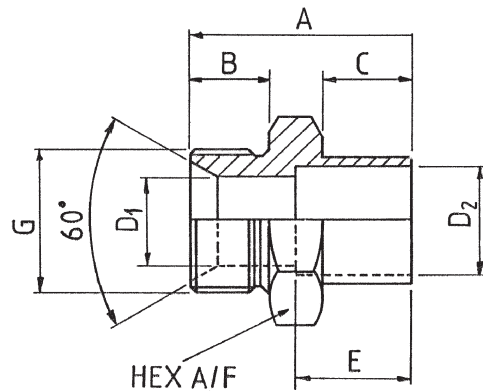

Part No.	BSP'P' Thread Size G	A	B	C	D ₁	D ₂	E	HEX 2
FMCS-125-2	1/8"	18.1	8.1	5.1	3.6	3.3	6.2	14.3
FMCS-125-4	1/4"	24.1	11.1	6.1	4.8	6.5	10.2	19.1
FMCS-125-6	3/8"	28.1	12.1	8.1	7.9	9.7	11.2	22.2
FMCS-125-8	1/2"	35.1	14.1	11.1	11.1	12.8	15.2	28.6
FMCS-125-10	5/8"	40.1	16.1	12.1	14.3	16.1	17.8	30.1
FMCS-125-12	3/4"	43.1	16.1	15.1	16.6	19.3	20.3	31.7
FMCS-125-16	1"	52.1	19.1	21.1	22.2	25.4	25.4	41.3
FMCS-125-20	1 1/4"	57.1	20.1	23.1	28.6	31.9	30.2	50.8
FMCS-125-24	1 1/2"	62.1	22.1	26.1	33.3	38.3	33.1	56.4
FMCS-125-32	2"	71.1	25.1	28.1	46.1	51.1	36.8	69.8

BSP'P' (CS) HEX MALE FOR BUTT WELD (OD) TUBE

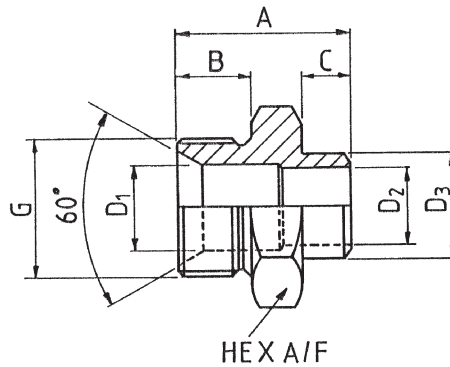

Part No.	BSP'P' Thread Size G	A	B	C	D ₁	D ₂	D ₃	HEX 2
FMCB-125-2	1/8"	18.1	8.1	5.1	3.6	1.6	3.2	14.3
FMCB-125-4	1/4"	24.1	11.1	6.1	4.8	2.4	6.4	19.1
FMCB-125-6	3/8"	28.1	12.1	8.1	7.9	3.2	9.5	22.2
FMCB-125-8	1/2"	32.1	14.1	8.1	11.1	6.3	12.7	28.6
FMCB-125-10	5/8"	38.1	16.1	10.1	14.3	9.5	15.9	30.1
FMCB-125-12	3/4"	38.1	16.1	10.1	16.7	12.7	19.1	31.7
FMCB-125-16	1"	43.1	19.1	12.1	22.2	19.1	25.4	41.3
FMCB-125-20	1 1/4"	48.1	20.1	14.1	28.6	22.2	31.7	50.8
FMCB-125-24	1 1/2"	50.1	22.1	14.1	33.3	25.4	38.1	56.4
FMCB-125-32	2"	59.1	24.9	16.1	46.1	44.4	50.8	69.8

CONE SEAT NIPPLES FOR SOCKET WELD (OD TUBE)

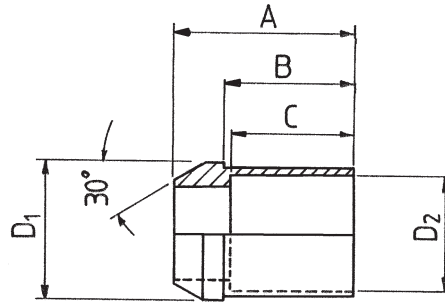

Part No.	A	B	C	D ₁	D ₂
CNS-125-2	14.8	8.3	6.3	8.4	3.3
CNS-125-4	17.2	11.1	10.2	11.3	6.5
CNS-125-6	21.7	12.7	11.4	14.7	9.7
CNS-125-8	25.1	16.8	15.3	18.4	12.9
CNS-125-10	26.4	19.1	17.8	20.4	16.1
CNS-125-12	34.1	22.1	24.1	20.3	19.3
CNS-125-16	40.2	28.8	26.6	30.2	25.9
CNS-125-20	43.1	32.1	30.2	38.7	31.9
CNS-125-24	48.5	35.2	33.1	44.7	38.3
CNS-125-32	54.3	39.6	36.8	56.6	51.1

CONE SEAT NIPPLE FOR BUTT WELD (OD TUBE)

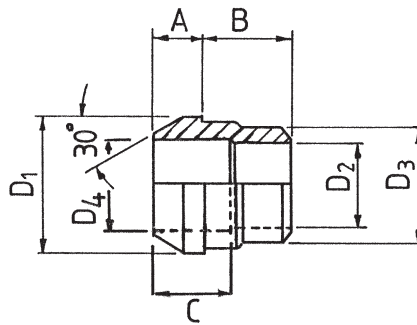

Part No.	A	B	C	D ₁	D ₂	D ₃	D ₄
CNB-125-2	6.6	8.3	6.6	8.4	1.6	3.2	3.2
CNB-125-4	6.1	11.1	7.9	11.3	2.4	6.6	4.7
CNB-125-6	9.1	11.1	9.5	14.7	3.2	9.5	7.2
CNB-125-8	8.4	12.7	9.5	18.4	7.2	12.7	7.5
CNB-125-10	7.1	14.3	9.5	20.4	9.5	15.9	12.7
CNB-125-12	11.9	17.8		24.1	12.7	19.1	12.7
CNB-125-16	11.4	19.1		30.2	19.1	25.4	19.1
CNB-125-20	11.1	27.2		38.7	22.2	31.7	22.2
CNB-125-24	13.3	30.4		44.7	25.4	38.1	25.4
CNB-125-32	14.6	30.4		56.6	44.4	50.8	44.4

CONE SEAT SOLID CAP

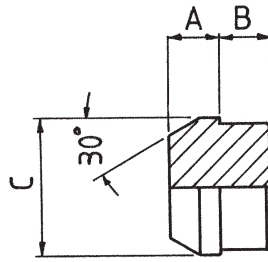

Part No.	A	B	C
CCSN-200-2	6.6	4.8	8.4
CCSN-200-4	6.1	6.4	11.3
CCSN-200-6	9.1	6.4	14.7
CCSN-200-8	8.4	7.9	18.4
CCSN-200-10	7.2	7.9	20.4
CCSN-200-12	11.9	9.5	24.1
CCSN-200-16	11.4	11.1	30.2
CCSN-200-20	11.1	11.1	38.7
CCSN-200-24	13.3	11.1	44.7
CCSN-200-32	14.6	12.7	56.6

BSP'P' HOSE NUTS

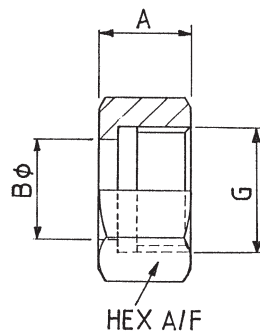

Part No.	BSP'P' Thread Size G	A	B	HEX
HN-125-2	1/8"	12.7	6.5	14.2
HN-125-4	1/4"	14.2	9.3	18.1
HN-125-6	3/8"	17.3	12.7	22.2
HN-125-8	1/2"	19.1	15.6	25.6
HN-125-10	5/8"	20.5	17.3	30.1
HN-125-12	3/4"	22.2	20.8	31.7
HN-125-16	1"	25.4	26.4	38.1
HN-125-20	1 1/4"	27.1	34.3	50.8
HN-125-24	1 1/2"	30.2	41.3	56.4
HN-125-32	2"	33.3	52.4	69.8

BONDED SEALS (NITRILE)

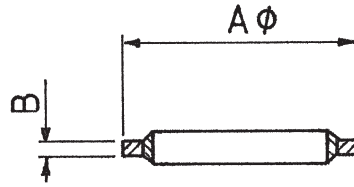

Part No.	A	B
DS-200-2	15.9	2.1
DS-200-4	20.5	2.1
DS-200-6	23.6	2.1
DS-200-8	28.5	2.5
DS-200-10	31.8	2.5
DS-200-12	35.1	2.5
DS-200-16	42.8	3.3
DS-200-20	51.5	3.3
DS-200-24	58.3	3.3
DS-200-32	73.1	3.3

RETAINING RING & NITRILE 'O' RING FOR BSP'P' MALE THREAD

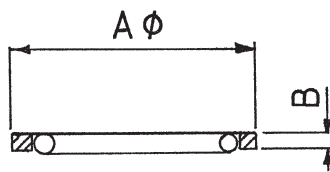

Part No.	A	B
RT-200-2	17.3	1.3
RT-200-4	19.1	1.3
RT-200-6	23.6	1.9
RT-200-8	28.6	1.9
RT-200-10	31.7	2.4
RT-200-12	34.9	2.4
RT-200-16	42.2	2.4
RT-200-20	50.8	2.4
RT-200-24	57.2	2.4
RT-200-32	71.1	2.4

***Custom
Fittings***

Rawfolds Way, Spen Valley Industrial Park, Bradford
Road, Cleckheaton,
West Yorkshire BD19 5LJ, England

Telephone: (01274) 852066

Telefax: (01274) 852029

E-mail: sales@customfittings.com Internet: www.customfittings.com