

12" - 50 W Vintage Alnico Loudspeaker  
P12N - 8Ω / 16Ω

General Characteristics			
Nominal Overall Diameter		307 mm	12 in
Nominal Voice Coil Diameter		38 mm	1.5 in
Magnet Weight		826 g	29 oz
Overall Weight		3.1 kg	6.83 lbs
Flux Density			1.26 T
Voice Coil Winding Depth		10 mm	0.39 in
Magnetic Gap Depth		8 mm	0.31 in

Thiele-Small Parameters		8Ω	16Ω	
Voice Coil DC Resistance	$R_E$	6.03	12	Ω
Resonance Frequency	$f_S$	90	91	Hz
Mechanical Q Factor	$Q_{MS}$	4.36	5.77	
Total Q Factor	$Q_{TS}$	0.77	0.84	
Mechanical Moving Mass	$M_{MS}$	30.9	27	g
Mechanical Compliance	$C_{MS}$	101	125	μm/N
Force Factor	$BxL$	10.62	13.71	Wb/m
Equivalent Acoustic Volume	$V_{AS}$	34.6	42.2	lt.
Maximum Linear Displacement	$X_{MAX}$	±1	±1	mm
Reference Efficiency	$\eta_0$	3.4	2.84	%
Diaphragm Area	$S_D$	490.9	490.8	cm <sup>2</sup>
Losses Electrical Resistance	$R_{ES}$	43	70	Ω
Voice Coil Inductance @ 1kHz	$L_E$	0.87	1.05	mH
Electrical Q Factor	$Q_{ES}$	0.94	0.98	

Constructive Characteristics			
Magnet			Alnico
Voice Coil Winding			Copper
Voice Coil Former			Kapton
Cone Material			Paper
Surround Material			Integrated Paper
Dust Dome Material			Solid Paper
Basket Material			Pressed Sheet Steel
Surround Treatment			No

Electrical Characteristics		8Ω	16Ω	
Nominal Impedance		8	16	Ω
Rated Power		50	50	W
Musical Power		100	100	W
Sensitivity@1W,1m		97.5	97.8	dB

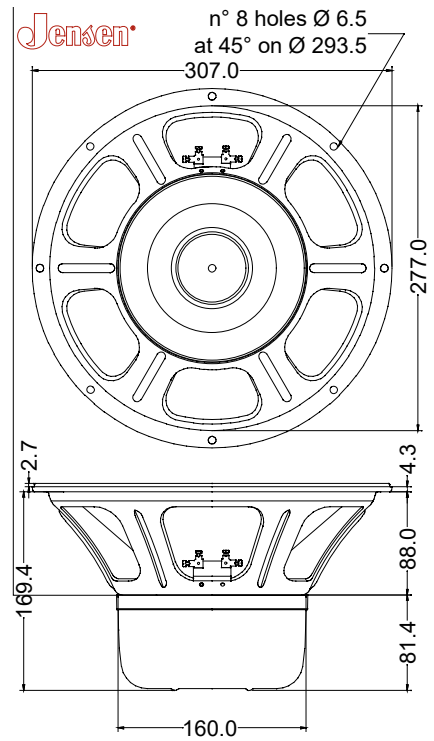

Note: all dimensions are in mm.

Frequency Response on IEC Baffle (DIN45575) @ 1W, 1 m - Free Air Impedance

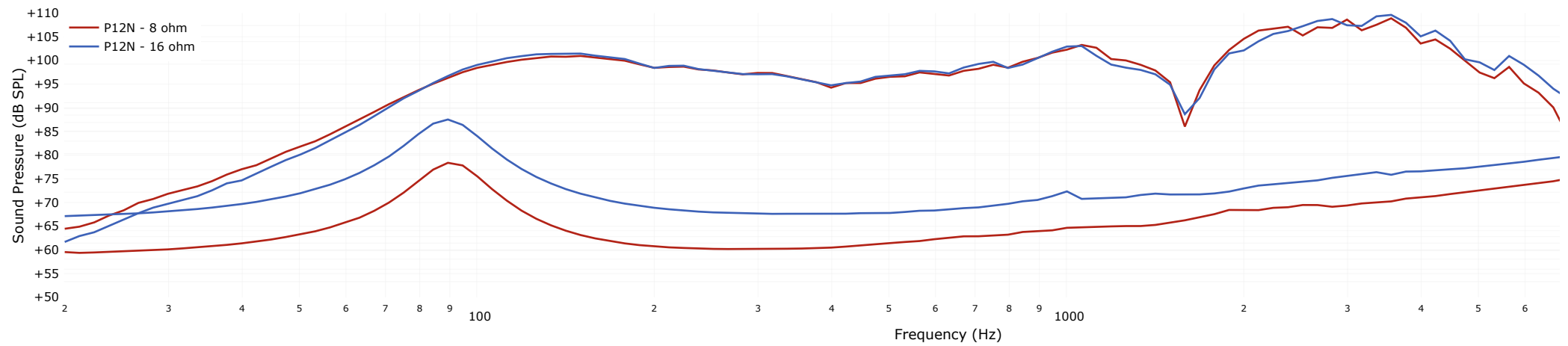



Due to continuing product improvement, the features and the design are subject to change without notice.  
Jensen Loudspeakers - website: [www.jensentone.com](http://www.jensentone.com)

02/04/2022 - 09:34