

WALLS FOR ROLLOUT AWNINGS

Return via fax to: 07 3284 5969 or email to: enquiries@aussietraveller.com.au - Brisbane
 Return via fax to: 03 9357 6515 or email to: info@aussietraveller.com.au - Melbourne

MEASURE DATE:	DEALER REP ID:	DEALER ORDER #:
DATE REQUIRED:	FOSTER REP ID:	CHASSIS #:
DEALER DETAILS: ADDRESS:		Standard Wall Layout <input type="checkbox"/>
PH: _____ FAX: _____		Custom Wall Design <input type="checkbox"/> Detailed over page.
CUSTOMER NAME		Gas Regulations:
		Checked that there are no gas appliances fluing into the annexe <input type="checkbox"/>
		Checked that there are no gas bayonets located in the annexe <input type="checkbox"/>
		Signed: _____ Dated: _____
RV: BRAND _____	MODEL _____	PT <input type="checkbox"/> FV <input type="checkbox"/> SIZE: _____
AWNING: SUNBURST CLASSIC <input type="checkbox"/> ECLIPSE <input type="checkbox"/> COLEMAN FAULKNER <input type="checkbox"/> CAREFREE FIESTA <input type="checkbox"/>		
ELECTROLUX 8300 <input type="checkbox"/> 8500 <input type="checkbox"/> OTHER <input type="checkbox"/>		
AWNING LENGTH:(CENTRE OF ARM TO CENTRE OF ARM) _____ Ft		
SPLINE SIZE ROLLER 4MM <input type="checkbox"/> 6MM <input type="checkbox"/> AWNING FABRIC COLOUR _____		
SAILTRACK FOR WALLS FITTED? YES <input type="checkbox"/> NO <input type="checkbox"/> IF NO, LENGTHS(IF REQUIRED) FRONT END _____ BACK END _____		

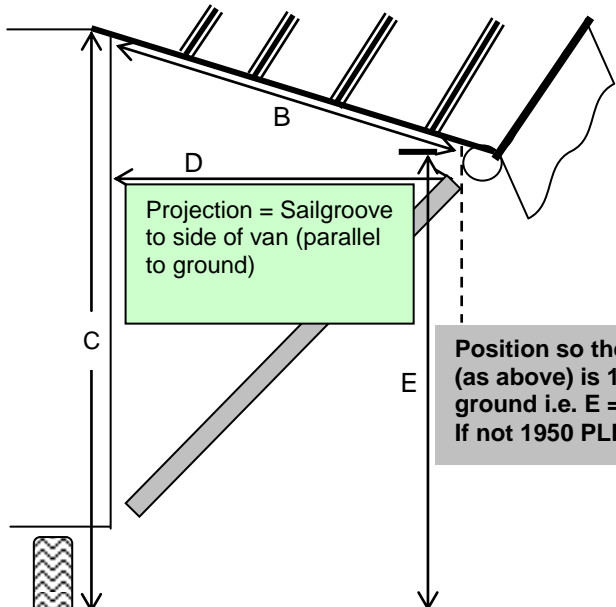

WALL CANVAS COLOUR: _____

Spline/Sailgroove in roller for pullstrap/longside wall, to be as close as possible to 3 o'clock/9o'clock

A Awning Fabric Length at Roller	A _____
B Blind Length Vinyl fabric length from side of van surround to roller sailgroove	B _____
C Back wall height fabric/sailtrack to ground length over axle	C _____
D Wall Projection-from sidewall of van to roller sailgroove	D _____
E [Long side wall] height sailgroove to ground Set at 1950 (if not 1950 advise new height)	E _____

NB: WITH AWNING ERECTED TO ABOVE MEASUREMENTS ENSURE DOOR TO RV IS FREE TO OPEN & THERE IS SUFFICIENT SLOPE FOR WATER TO RUN OFF. IF NOT ADJUST TO ALLOW SO.

Delete/select ONE winds skirt layout

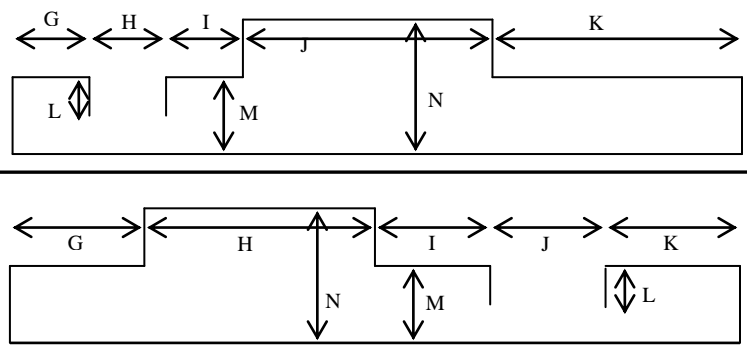

POPTOP

1. _____
2. _____
3. _____

G	L		
H	M		
I	N		
J	STEP STYLE:		
K	PULL DOWN		
TOTAL	SOLID		

NB: WINDSKIRT MEASUREMENTS SHOULD ADD UP TO NOMINATED AWNING LENGTH LESS 1'(300MM) IE: MEASURED 6" IN FROM THE CENTER OF EACH FRAMESET ARM. NB: WINDSKIRT CAN BE LENGTHENED IF NEEDED TO ALLOW END WALL TO PASS AROUND WINDOW FRAMES ETC.

CHECK FITTING SETTINGS

ARMS
 ROLLER
 SKIRT
 WALLS