

**Product** KAHUNA Massage Chair  
**Model** HM-KAPPA  
Developed by AJX Distribution Inc  
11125 Knott Ave, Suite D  
Cypress, CA 90630  
**Tel** 1-855-646-9500  
**Email** INFO@KAHUNACHAIR.COM

You must register warranty at [www.kahunachair.com/services/](http://www.kahunachair.com/services/)

K A H U N A M A S S A G E C H A I R

# HM-KAPPA MANUAL

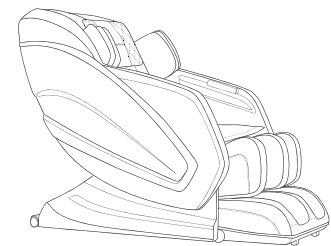

Please read this user manual thoroughly prior to operating the massage chair. Store this booklet for future reference.



KAHUNA  CHAIR®

Introducing the new Rhythmic Human Massage Chair

# HM-KAPPA

**Sensual Touch, Refined Design with state-of-the-art technology, Luxurious contemporary massage chair.**

- New **4D RHYTHMIC SKMS-09M-225L** massage system - Over 10,000 experienced user feedback, we have precisely improved our system based on UX. Based on kahuna chair user's reviews, we have developed a more intelligent and sensual massage chair. It will improve your body condition to be at it's best when using our new and improved massage chair.
- **Hyper SL-Track** (51.2 inches) is the most ergonomic massage chair track that can reach every inch of your spinal curvature.
- **Rhythmic Kahuna air-cell movement** system contains 96 individual air-cells that help promote better blood circulations and increase oxygen levels.
- **Smart User memory function** will remember your favorite features such as heating, zero gravity angle, spine roller speed, foot roller speed and air intensity settings to assist you to get in a faster comfort zone.

- **15 unique massage programs** to accommodate all type of body conditions.
- **New Backlit remote control** will give you total control in the dark and our soothing led light on the side of the chair will relax your mood and give you better vision at night.
- **Kahuna Tablet** and holder are also included for multi-purposes. Tablet equipped with a fast quad-core 1.5 GHZ CPU can be used as a remote and able to connect online to watch youtube or do other fun activities while enjoying the massage. You can connect to our premium Bluetooth speakers on the chair to enjoy full premium sound quality.
- Mix and match color options will give you up to 16 Different color options to match your home decoration.
- Able to accommodate user's height between 5' to 6.2' and weight up to 330 lbs.





Please read and follow all safety and operating instructions listed in this user manual prior to use. Basic precautions should always be used when operating the chair.

# CONTENTS

Safety Instructions	.....	1
Product Components	.....	4
Chair Installation	.....	5
The adjustment before massage	.....	10
Remote Controller	.....	11
Auto Programs	.....	13
Manual control	.....	14
Connect app & speaker	.....	16
Troubleshooting	.....	19
Product Specifications	.....	20

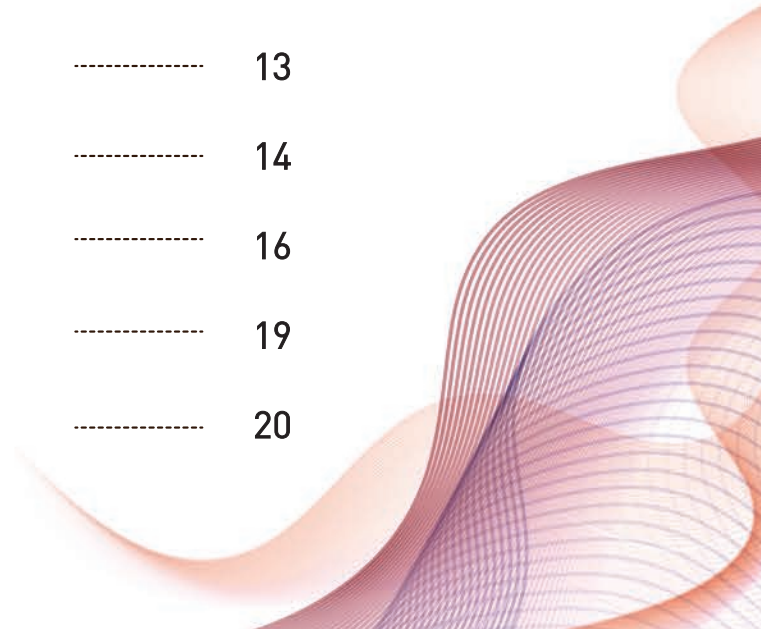



# SAFETY INSTRUCTION





Thank you for purchasing the HM-KAPPA massage chair.

- Please read this manual thoroughly before using.
- Please keep this manual for further use.
- Please pay attention to the safety precautions.

• **Two parts for safety precaution: warning and attention.**

 Warning	Alarm for serious accident as hurt or death.
 Attention	Alarm for hurt or damages for goods.

• **Presentation from below symbols.**





	The activities which were forbidden to do.
	Request user to follow the instruction.
	Self-dismount was forbidden.
	The correct operating way to pull out power plug.

- Carefully read and follow this instruction book to assemble and operate.





**NOTE**

Right to make changes: We reserve the right to make changes to information published in this document, including without limitation specifications and product descriptions, at any time and without notice. This document supersedes and replaces all information supplied prior to the publication here of. The picture is for reference only. Please adhere to the original products in case of any mistake.

 **Warning**

	<ul style="list-style-type: none"> <li>• Patients with serious hyperostosis.</li> <li>• Swollen lump and patient of thrombosis. Patients with serious heart troubles.</li> <li>• Women who are pregnant or may become pregnant.</li> <li>• Children or people who have consumed alcohol or drugs.</li> <li>• Do not sleep on this machine.</li> </ul>	Not recommended
	<ul style="list-style-type: none"> <li>• Before using this machine, please confirm there is enough space for the chair to recline.</li> <li>• Any uncomfortable feeling from massage is suggested to consult with a doctor.</li> <li>• Do not offer hard massage for your head.</li> <li>• Do not massage the abdominal region and knee cap. Special care while massaging neck.</li> <li>• Do not allow the kids to be near the chair, especially while operating.</li> <li>• Need supervision, if the user is mobility impaired or has a communication barrier.</li> </ul>	Accident or hurt
	<ul style="list-style-type: none"> <li>• Connect the power cable of this machine on a suitable socket.</li> <li>• Make sure to the push the plug in the socket all the way.</li> <li>• Plug out after the massage.</li> <li>• Stop all the massage functions and turn the power switch to off before plugging the cord out.</li> </ul>	Fire or electric shock
	<ul style="list-style-type: none"> <li>• Please do not store the cushion of this machine under folded.</li> <li>• Do not disconnect or connect the plug to the socket with a damp hand, which may result in electrical shock or mechanical trouble.</li> <li>• Please make sure that the power plug is plugged all the way into the socket without attaching any pin or rubbish, for which may cause electrical shock, short circuit or fire.</li> </ul>	Accident
	<ul style="list-style-type: none"> <li>• If this machine is not operating correctly, or broken, or damaged from other reasons, please contact service department first at <a href="mailto:service@kahunachair.com">service@kahunachair.com</a>.</li> <li>• If the plug or power cable is damaged, please contact service department.</li> <li>• Do not dismount any parts of this machine privately, unless asked to do so.</li> <li>• Please check carefully over the cushions and coverings to confirm they are in good condition.</li> </ul>	Dismount and maintenance

**⚠ Attention**

	<ul style="list-style-type: none"> <li>Do not place or stock this machine particularly near damp place such as, wet floor, bathroom, etc.</li> </ul>	Avoid from electric leakage or shock
	<ul style="list-style-type: none"> <li>Must confirm it is under good earth connection.</li> <li>Do not use a plug adaptor.</li> </ul>	Avoid from electric accident
	<ul style="list-style-type: none"> <li>Stop the power supply, before cleaning.</li> </ul>	Avoid from sudden accident
	<ul style="list-style-type: none"> <li>Stop the power supply, after the massage.</li> </ul>	
	<ul style="list-style-type: none"> <li>Pull out the plug, if there has any electrical problem.</li> </ul>	
	<ul style="list-style-type: none"> <li>While unplugging the power supply, do not directly pull from the power cable.</li> </ul>	
	<ul style="list-style-type: none"> <li>Do not use this chair in hot, damp, or corrosive environment.</li> </ul>	Avoid from damages to the machine cover
	<ul style="list-style-type: none"> <li>Do not use electric blanket on the machine.</li> </ul>	
	<ul style="list-style-type: none"> <li>Do not place near or expose it to direct sunlight.</li> </ul>	
	<ul style="list-style-type: none"> <li>Do not use it outdoors.</li> </ul>	

 Grounding unable to connect these space

Gas pipe may cause electrical shock, short circuit or fire.  
 Telephone lines and Lightning rod : may cause electrical shock, short circuit or fire conduit: on plastic can't have a function.

# MAIN BODY DIAGRAM

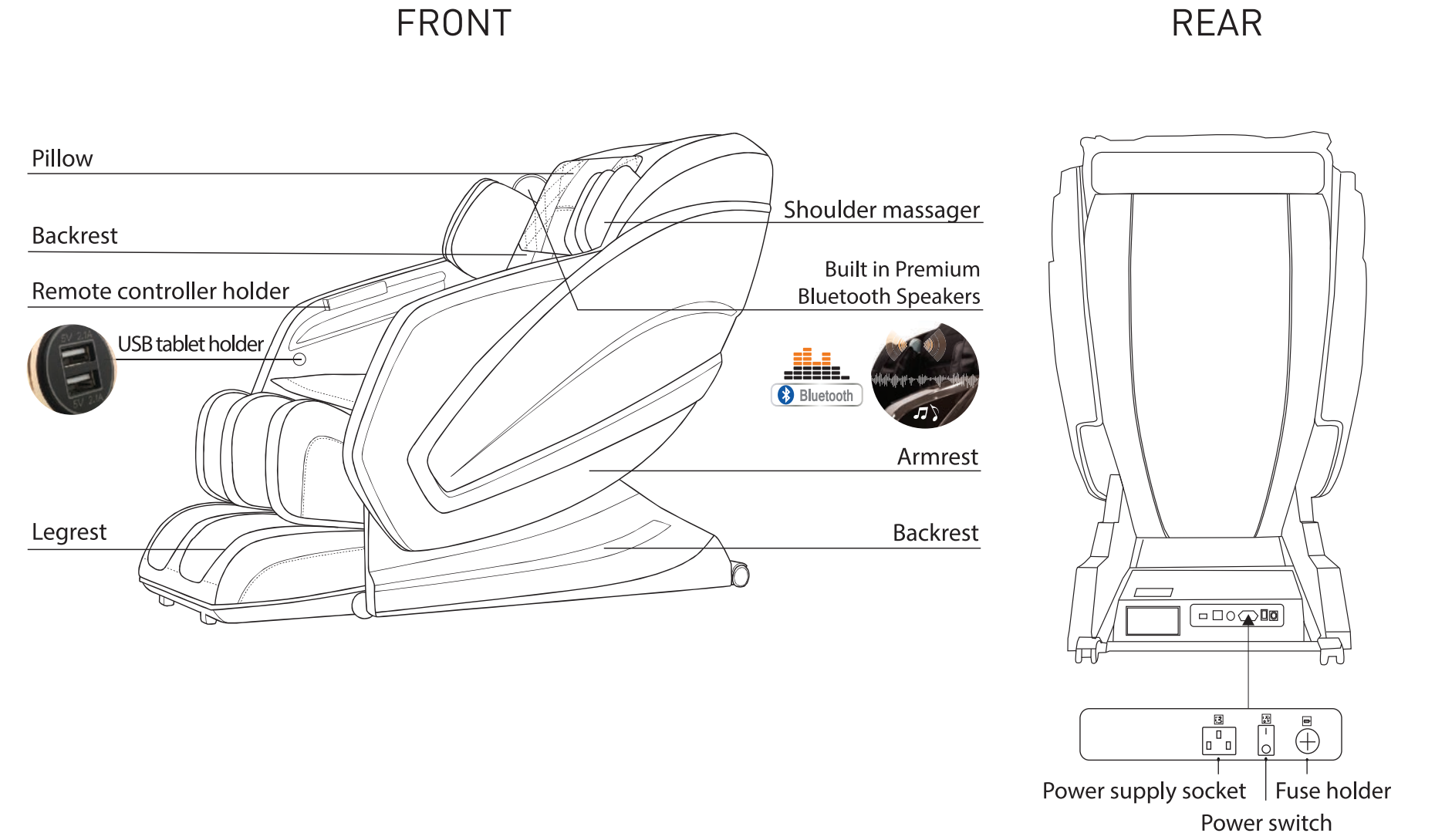

## STEP 1 - Unpack the box

Box 1 : Carry out the main body, leg part, and accessory box, when carrying out the main body, we suggest at least two people help.

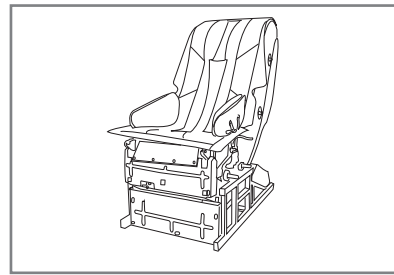

Main body

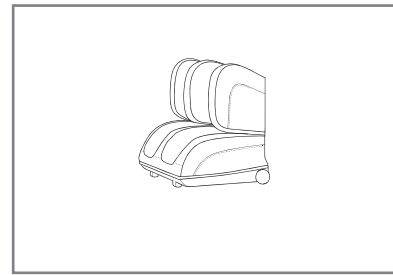

Legrest

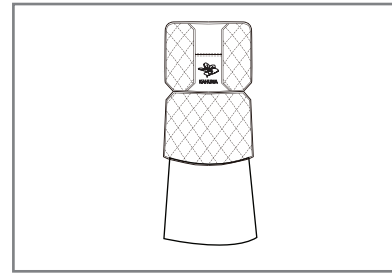

Pillow

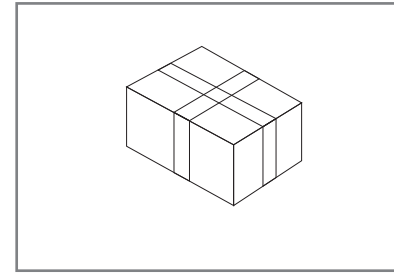

Accessory box

Box 2 : Take out the armrests lower side skirts, and remote.

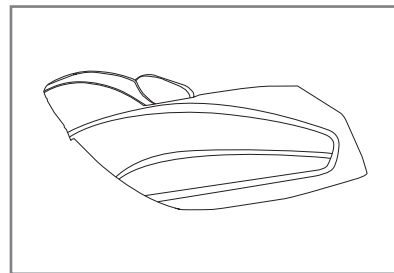

Armrest (Right)

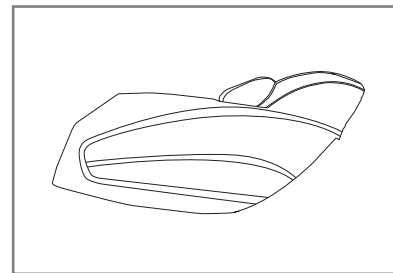

Armrest (Left)

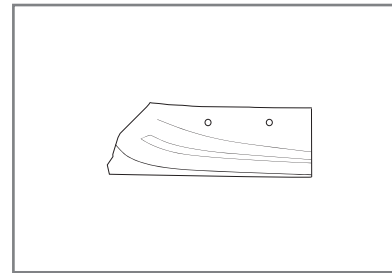

Side skirt (Right)

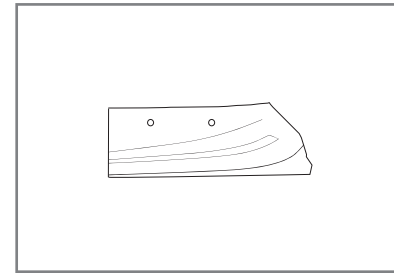

Side skirt (Left)

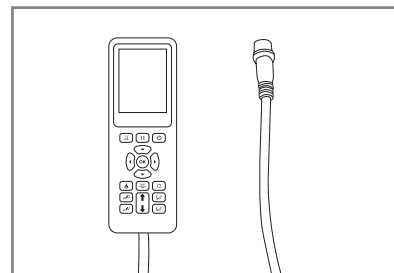

Remote

## STEP 2 - Install the legrest

❶ Unscrew the screws to open connectors and connect air hose and power cable.

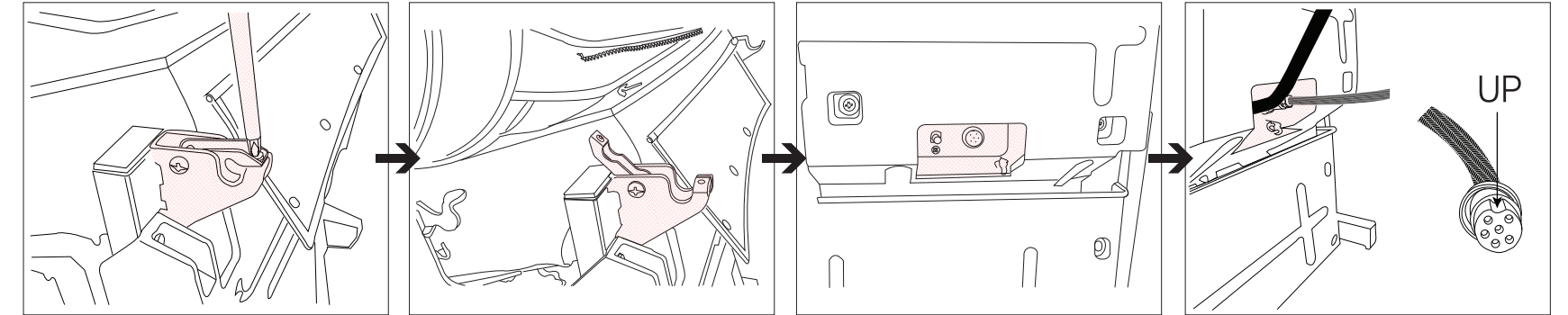

❷ Hang the leg part as shown as a picture to the leg part adapter of the main body, fix it with screws. And then zip up the leather case between the leg part and seat cushion.

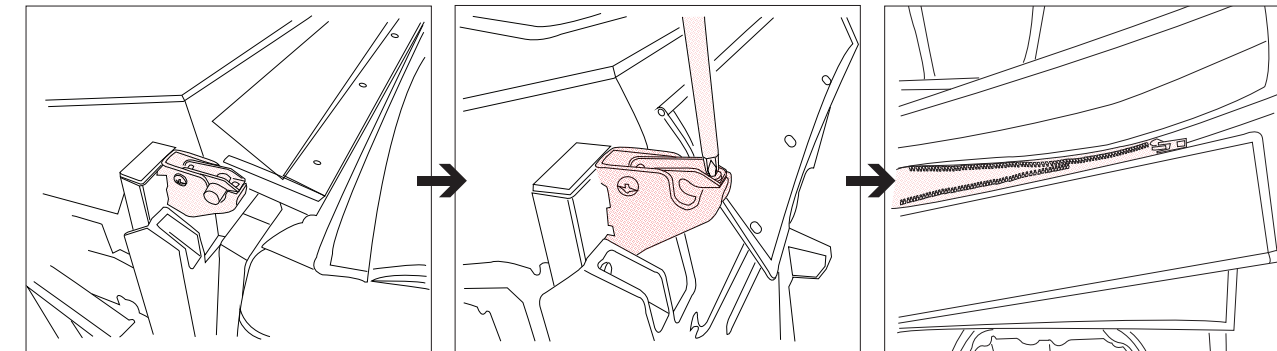

## STEP 3 - Install the base cover

- 1 Insert the bottom of the base cover to the base frame of the main body from top to bottom. And then Fix it with screws.

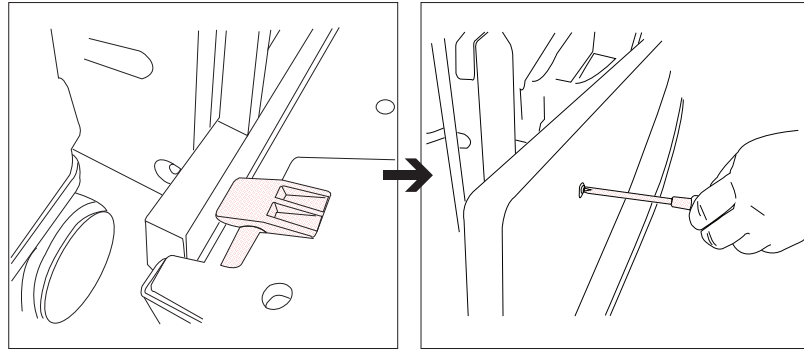

## STEP 4 - Install armrest

- 1 Lift the front part, then aim the side parts card at the fixed axis of the main body (as part 1 in the picture). Pull the spring hook and push inward hard to fit correctly.

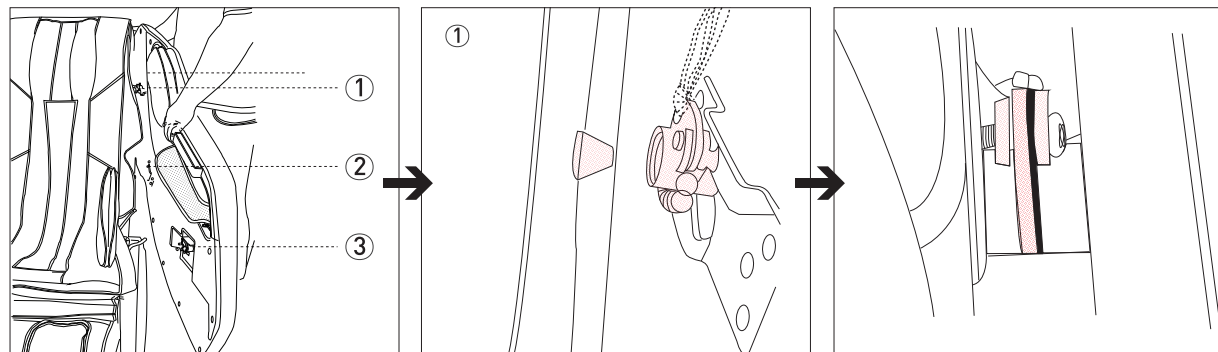

- 2 Set the armrest closely to the main body (as picture 2). Insert the parts card into intermediate shaft of the main body from the top to the bottom slowly.

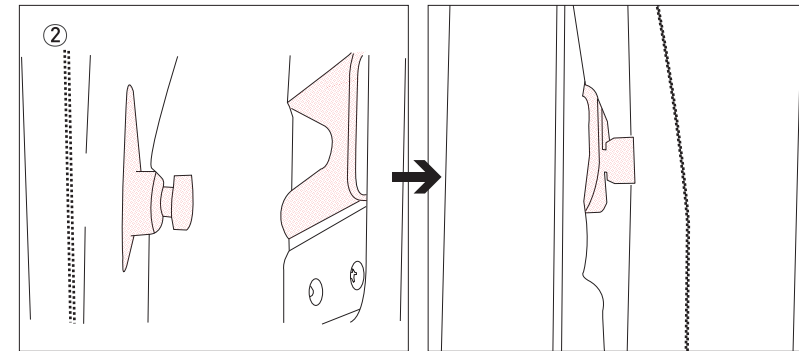

- 3 Connect the air hose and power cord to the main body.

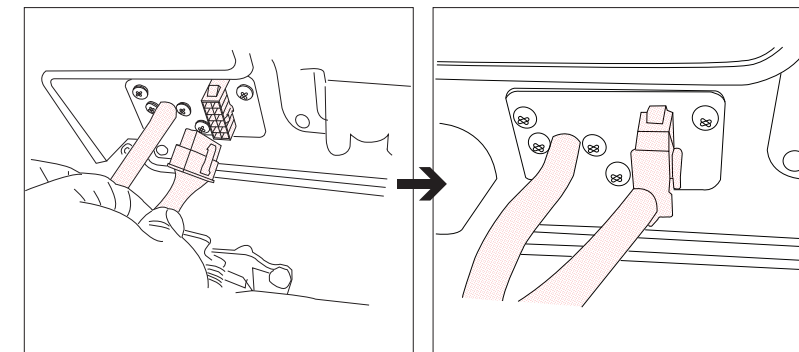

- 4 Finally, insert the fixed block (as picture 3) into the fixed axis of the main body from the top to the bottom.

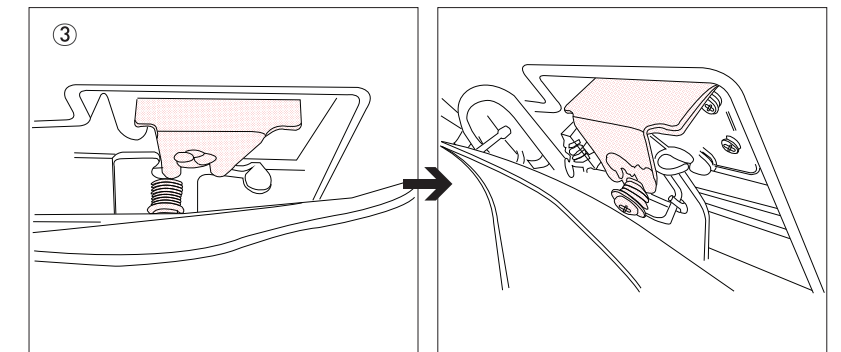

## STEP 5 - Install the back cushion, remote and tablet holder

- ❶ Zip up the back cushion to the chair seat area.

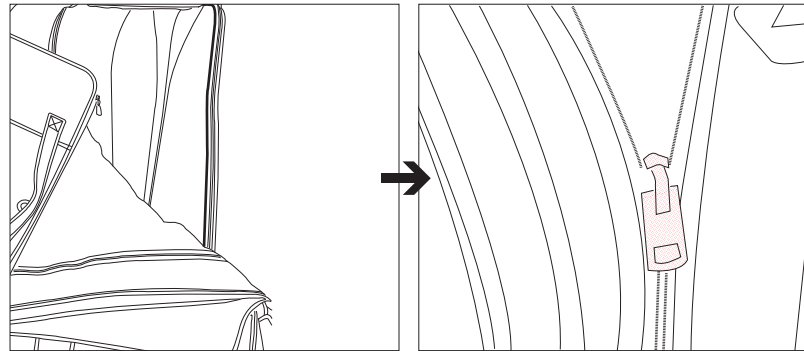

- ❷ Connect power cord for remote to the main body.

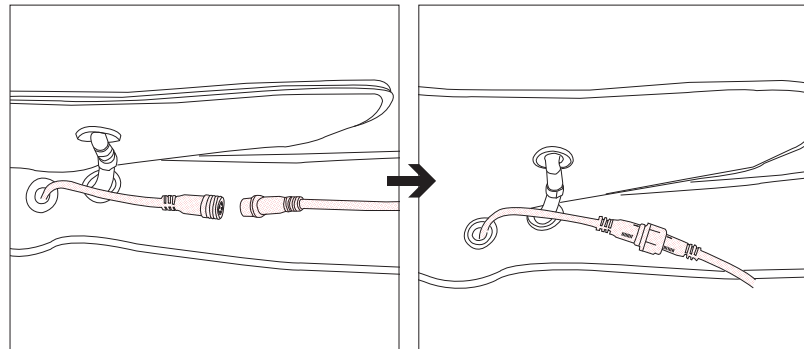

- ❸ Use the allen wrench to tighten the tablet holder.

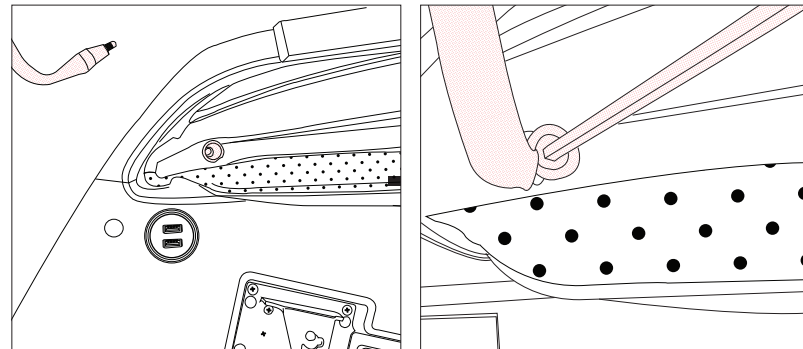

## THE ADJUSTMENT BEFORE MASSAGE

The chair can be easily moved with the wheels on the lower back. While moving, please raise the front part of the chair as the picture shows, and move the chair to any suitable place.

### TIP

1. Remove the power cord before moving.
2. While moving, never shake the chair, never pull the leg part, never release the backrest suddenly and let the chair hitting the floor.
3. If the floor is wooden or other materials which is easy to be scratched, please don't use the wheels, lift it up by at least 4 people.
4. As the chair is heavy, we suggest at least two people to help while moving.
5. Never move it when the chair is in a reclined position.
6. Add a thick cloth (like a carpet) at the bottom to help to drag the chair.

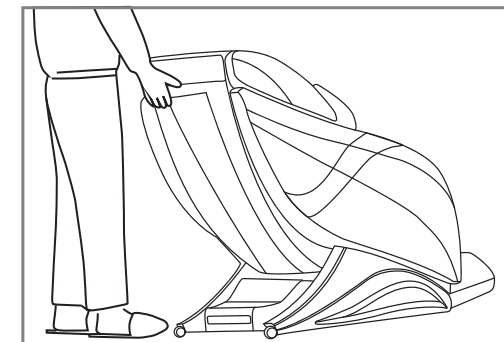









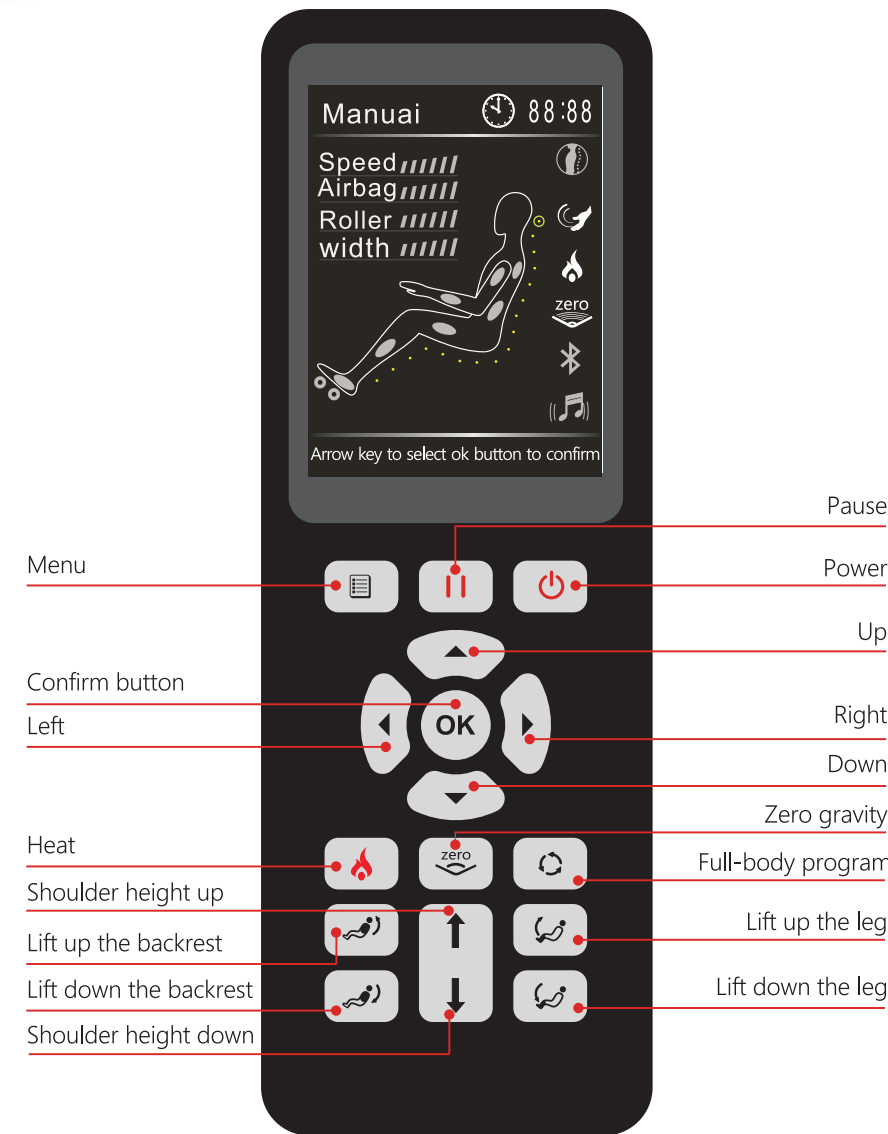







### ⚠ Attention

Never move the chair when the chair is working. (To prevent an accident or a damage)



# REMOTE CONTROLLER



-  **Power** : On/off key of the chair.  
- Press this key, the chair will start to work.  
- Press it again, the chair will shut down and go back to the reset position.
-  **Pause** : When the chair is working, press this key, all actions will be suspended, press it again, all the actions will recover.
-  **Menu** : You can choose programs, massage methods, setting functions by pressing this key.
-  **Shoulder position adjustment** : Adjust the height of the back rollers by holding down button for either direction.
-  **Auto program switch** : Press this key to choose and switch between pre-saved auto programs.
-  **Direction** : You can press the up/down key to choose, and press right key to enter sub-directory, press left key to back parent directory, the OK key is for confirm selections.
-  **Leg extension position adjustment** :  
  -  Leg will manually extend the length
  -  Leg will manually shorten the length
-  **Zero gravity** : Press this key to enter zero gravity position, the zero gravity icon on the display will be light up, and will turn off when you adjusting the backrest / leg part angle by manual, which will make the chair out of Zero gravity position.
-  **Position up the legrest** : By holding down this key, the leg part will lift up.
-  **Position down the legrest** : By holding down this key, the legrest will put back down.
-  **Position up the backrest** : By holding down this key, the backrest will lift up.
-  **Position down the backrest** : By holding down this key, the backrest will put back down.
-  **Heating** : Pressing this key, the heating system will be turn on, and the heating icon on the display will be light up, press it again the heating system will be turned off, and the icon turn into grey.

# AUTO PROGRAMS

Press "  " button to enter "Auto program" or press menu button to enter auto program list.

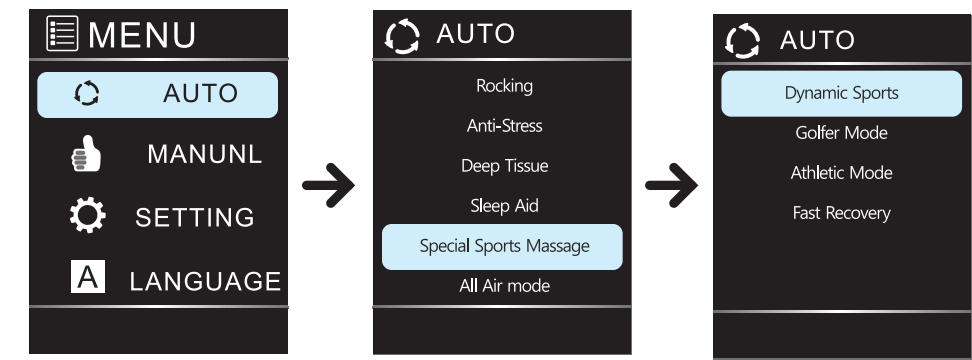

**Renew**  
New Kahuna full-body massage program with strong rhythmic 3D dimensional air squeeze techniques and moderate massage with kneading, tap, and roll techniques from neck to glutes to recharge your body. Sophisticated massage performance to covers acupuncture points to relieve tension to renew your day.



**Kahuna Yoga Stretching**  
Inspired by yoga movements, Kahuna Yoga Stretching mode massages the spine with a sequence of rolling and kneading and intensify the stretching with pausing movements. It also has a side to side twist motion with hip airbags while it stretches full-body and areas not stretched on the daily.



**Kahuna Twist Stretching**  
The most popular Kahuna signature auto program for full-body stretching with firm glute massage and thigh stretch. Airbags inflate to hold upper and lower body as chair changes into different positions.



**Kahuna Active Stretching**  
The Most active stretching program that combines Kahuna & yoga stretching techniques along with unique hamstring pressure massage to target overused and tense muscles.



**Kahuna SV-Chiro**

Inspired by Chiropractic movements, massage begins with knocking and tapping motion to relax the muscles next to spines and rolling and kneading action expands the gaps between the spines and help better alignment of your core.



**Rocking**

Gentle rocking motion movements with soft full-body massage auto program that provides soft rolling technique along the back muscles to stimulate circulation with light full body air-cell massage with foot rollers that cradles you to sleep.



**Sleep Mode**

Daily use program with a combination of gentle roller and light air-cell massage system to promote relaxation and soothes body to help to fall asleep better. Soft transitions of kneading, rolling and rocking up and down the spine for full relief.



**Anti-Stress**

Strong upper body care massage program with a full motion that starts with a shoulder to head air-cell massage to blow away your tension. With deep rolling on the entire back while it fixes points in specific areas to massage acupressure points. Air-cells also squeezes waist and hip tightly to help promote better circulation. This program will be beneficial for people who have desk jobs that have a stiff neck and performs instant relief for the stressed body.



**Golfer Mode**

Golfer massage program focuses on lower body massage that especially targeted for tension around the hip region. Also provides stretching in pelvic and waist area by multi squeezing actions using air-cells. Air-cells on calves and foot shift side to side creating a slight twisting motion to boost overall massages.



**Kahuna Twist Chiro**

More active Chiro massage program that includes Kahuna Chiro movements with side to side twist motion for waist, thigh and helps better strengthen your core more actively.



**All Air Mode**

The New special auto program that only performs with rhythmic air-cell pressure massage system to massage full-body. Kappa equipped with 107 airbags that gradually inflate, squeeze and embrace your entire body with wave-like motion promoting blood circulation and loosens tense muscles.



**Deep Tissue Massage**

Intensive body care massage program that penetrates deeply into the tissues. Deep knocking and tapping roller actions on lower back and firm acupressure calf massage from air-cells to complete strong full-body care.



**Dynamic**

Dynamically massages with rollers along the spine that allows muscles to get flexible before work out with a variety of different sequence while stretching lumbar and glutes. Enjoyable massage anytime for your need before the active day.



**Athletic**

Combination of Dynamic massage program with light tapping motion that relaxes and warms up your muscles before game time.



**Fast Recovery**

Recovery massage program is a recommended program after the exercise. Combination of gentle kneading and tapping roller actions to relax muscles along with rhythmic air-cell massage system on full-body to promotes better circulation allowing more oxygenated blood to muscles for faster recovery and reduce possible injuries.

**AIR BAG**

This subdirectory is for managing the air bag system, contains part and intensity option.

**Section :** In this subdirectory, you can turn on / off some air bags by choose it and select the off / on button.

**Intensity :** This is for adjusting the air pressure intensity, offer 5 degree for option.

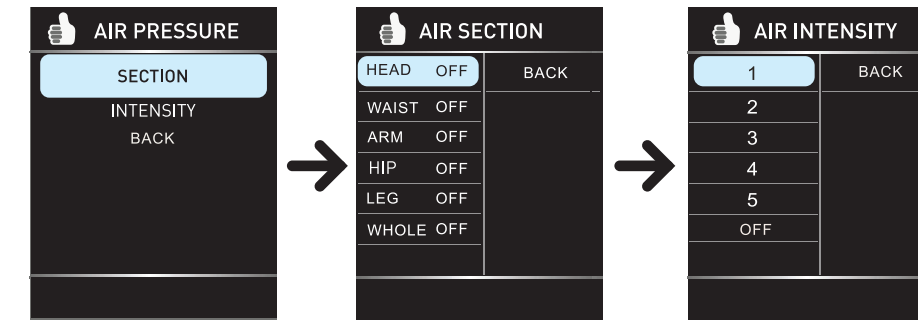

**SETTING**

Press "Menu" key, choose "Setting", enter the subdirectory.

**Time :** Setting worktime.

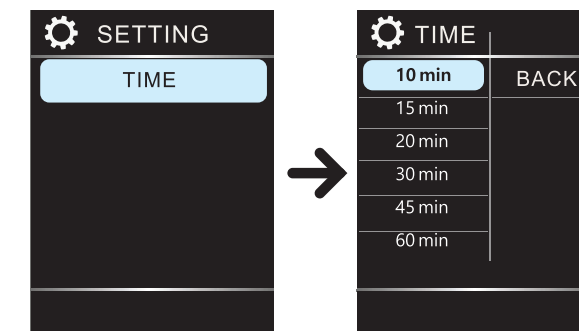

**FOOT ROLLER**

Choose roller, in the subdirectory, you can adjust the roller speed, offer 3 grades for option.

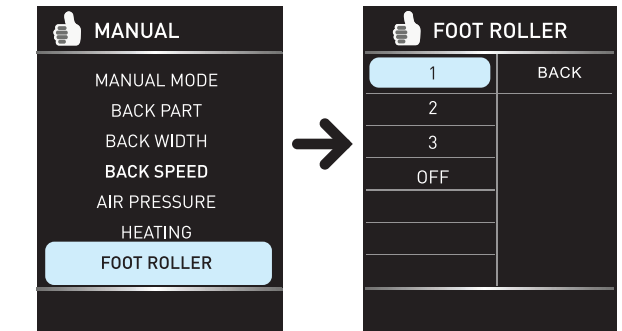

**LANGUAGE**

Click the "Menu" button, then choose the "Language" to start language. Use up/down key to choose, OK to confirm.

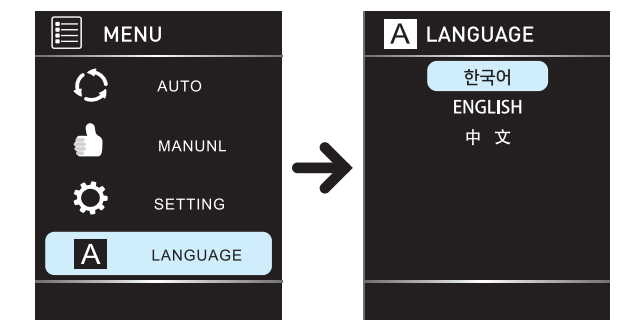

**HEATING**

Press "Heating" key, enter the subdirectory. Approximately mild is 30°C warm is 45°C, hot is 55°C.



# MANUAL MODE

Click the "Menu" button, then choose the "Manual" to start the manual program. Use up/down key to choose, OK to confirm.

**Massage method** : In this subdirectory, you can use up / down key to choose. There are six massage methods: Kneading, Rolling, Knocking, Finger-p, Dual action, Tapping.

**Part** : This subdirectory is for back roller massage range, us up/down to choose. Offer 3 options : Full body, partial, fixed.

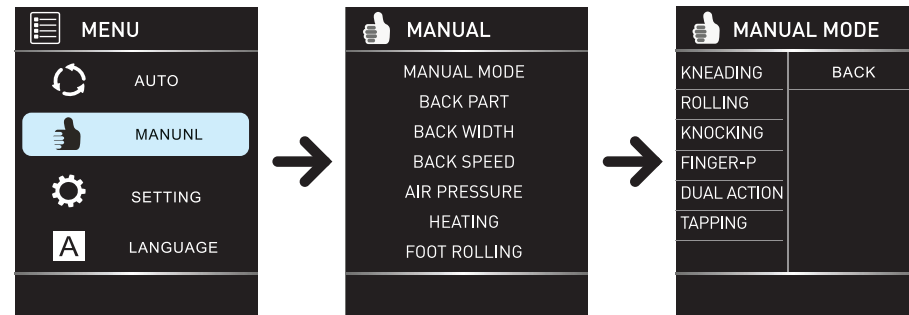

**Part** : This subdirectory is for adjusting the massage part of the back rollers. Offer full body, partial, fixed for the option.

**Speed** : This subdirectory is for adjusting the massage speed of the back rollers. Offer 6 degree for the option.

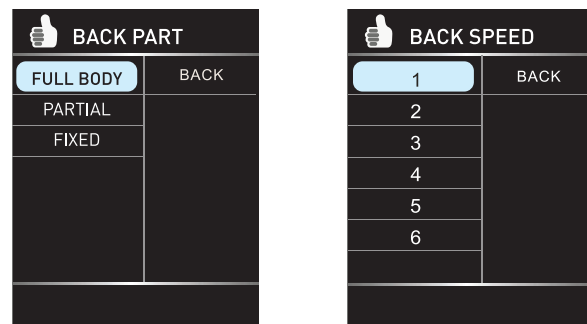

# TIPS

1. Under auto / manual mode, the display will switch to the home page after 10 seconds without any operation.



Home page while under manual mode



Home page while under manual mode

- During working, press "Menu" twice, it will go back to the home page immediately.
- In the home page, under the manual / auto program, press shoulder position key to adjust the highest position of the back rollers.
- Press "auto" key to choose auto program.

2. Before running the auto program, it will detect shoulder position first. After the detection, it will switch to the auto program.

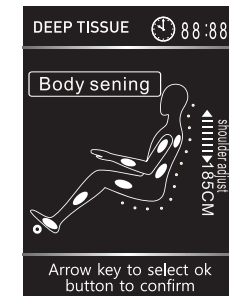

# CONNECT APP & SPEAKER

1. To connect app and speaker, you must enable the audio function on Bluetooth by going into Bluetooth setting on your phone or tablet.
2. To download app, please search HM-KAPPA from app store.
3. After connecting to Bluetooth, please go to Bluetooth from the setting and choose HM-KAPPA.

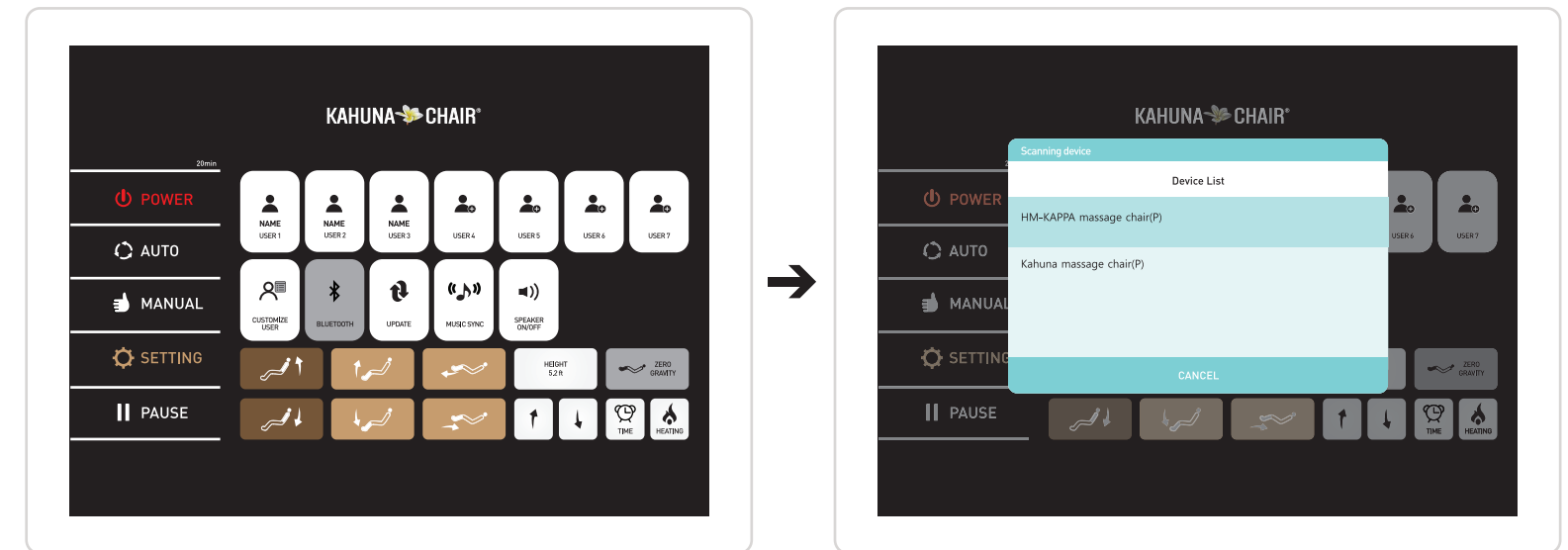
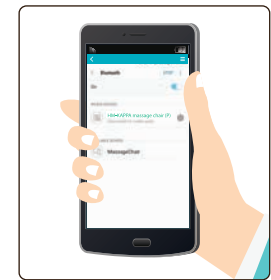

## Auto Program Interface

HM-KAPPA provides 15 specially designed auto programs for different needs.

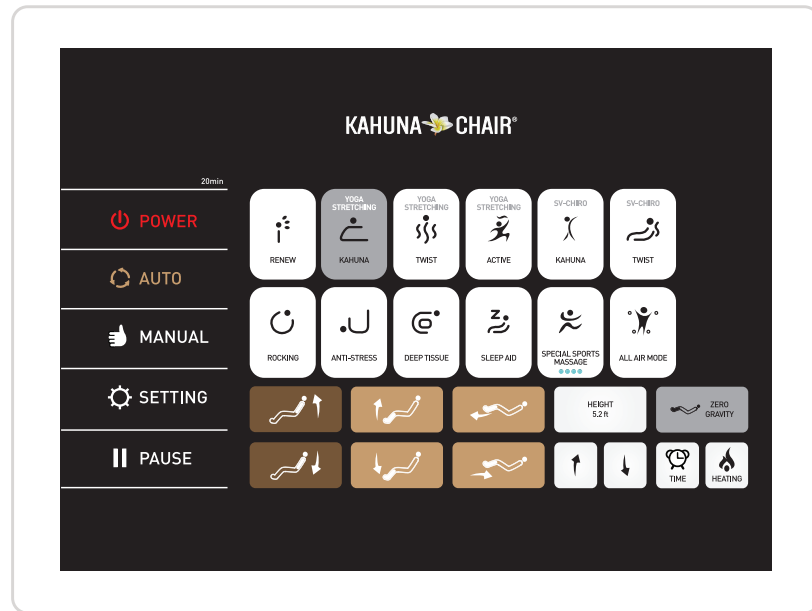

## Manual Program Interface

HM-KAPPA can also do manually select massage functions and customize the massage section.

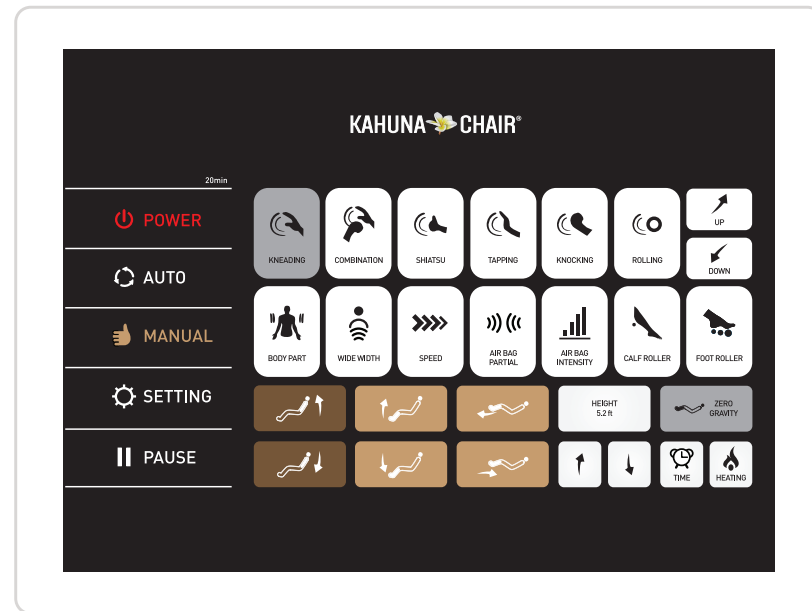

## Customize User Setting

1. Select the customize user.

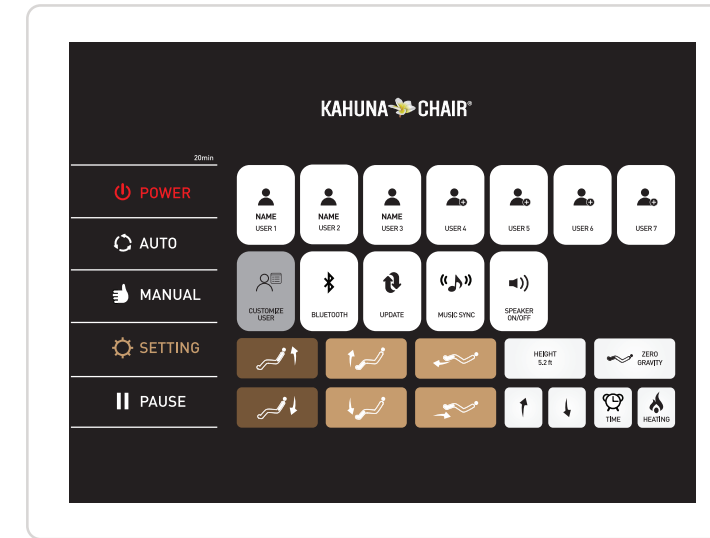

2. Select the user to choose and customize user setting.



3. Customize auto or manual programs by select the auto/manual.

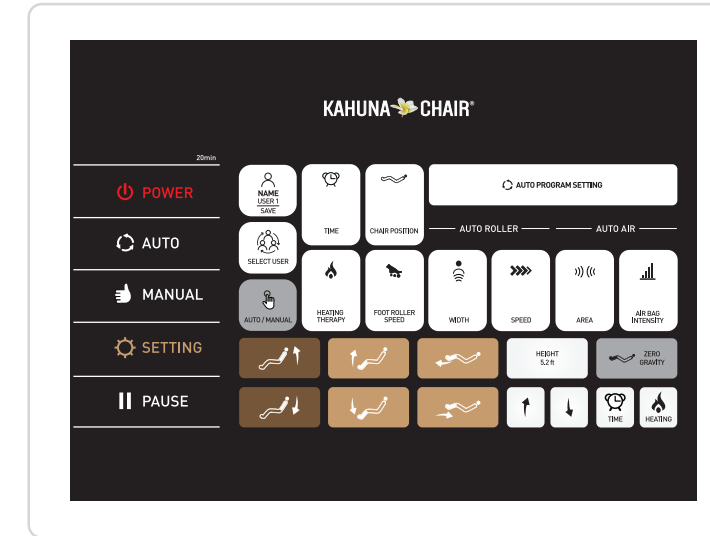

4. Press the user to save the customized setting.



## TROUBLESHOOTING

855.646.9500 / 1.714.388.2625, service@kahunachair.com

Trouble	Possible reasons	Troubleshooting
Can not work after supplied power	Didn't turn on the power switch.	Turn on the switch.
	Didn't choose massage program.	Choose a massage program.
	Bad connection between plug and socket.	Connect again.
	Power cord or plug damaged.	Replace the power cord.
	The fuse burned up.	Replace the fuse.
	A fault in the controlling circuit.	Contact with service department.
Working with tap-tap-tap or hum sounds	Sounds from air pump, motor or other mechanical parts.	Normal phenomenon
Different height of the massage rollers	Rollers operating for too long.	Normal phenomenon
Abnormal sounds suddenly occurred while working	If after long time of operating.	Cut down the power and check after 30 minutes.
	Cause from a long time of operating.	Contact with service department.
Suddenly stopped working	If after long time of operating.	Supply power again.
	Auto programmed time is up.	Cut down the power and use after 30 minutes.
Can not recline	Obstrucater there ; operations overloaded automatically stopped operating for protecting machine.	To move the obstrucater ; stop work and use after 30 minutes.
Can not restore after relined	Problem on electromotion pole or plug-ing under bad connection.	Contact with service department.
Control panel overheat seriously	Cause from long time of operating.	Cut down the power and call service department.
Abnormal overheat from power wire and plug	Operation overload.	Cut down the power and use after 30 minutes.
	Causes from other resons.	Cut down the power and call service department.

⚠ Note: If problems all are not from above reasons, please stop the chair and contact us.

## PRODUCT SPECIFICATIONS

Description	Specifications
Product Name	Kahuna Massage Chair HM Series
Model No.	KAPPA
Rated Voltage	110-120V~
Rated Frequency	50/60Hz
Rated Power Consumption	170 W Max.
The Estimated Main Box	47.2 x 25.2 x 47.2 inches (LxWxH)
The Side Panel Box	57.5 x 17.7 x 28.7 inches (LxWxH)
Weight (LBS)	The Main Box Gross Weight : 265 lbs
	The Side Box Gross Weight : 104 lbs
	Net Weight : 278 lbs

**KAHUNA CHAIR PRODUCT WARRANTY REGISTRATION**  
<https://www.kahunachair.com/services/>

