

CBO-750 DIY KIT Specifications



UPC 810096800060 | SKU CBO-O-KIT-750

Details

- 6-Piece Oven (Dome, 3-piece Hearth, Arch, Decorative Door)
- Install Kit (Anchor Box with DuraVent #9441 6-Inch Anchor Plate, 6 Bolts, 3 Insulation Boards, Insulating Blanket, 18-Gauge Galvannealed Steel Plate, Mortar, Installation Manual)
- Accessory Package (Pizza Peel, Brush, Infrared Thermometer Gun)
- Hearth Cooking Surface 38.25" x 28"

- Support weight minimum: 480 lbs
- Piece weight:
 - Dome 299 lbs
 - 3 piece Hearth 96 lbs
 - Arch 21 lbs

Bolt Dimensions:

- 2 Anchor plate bolts (ss 1/4-20 x 1/2")
- 2 Arch bolts (ss 1/4-20 x 2 1/2")

(Steel Plate Dimensions: 1/20"x 33"x 40")

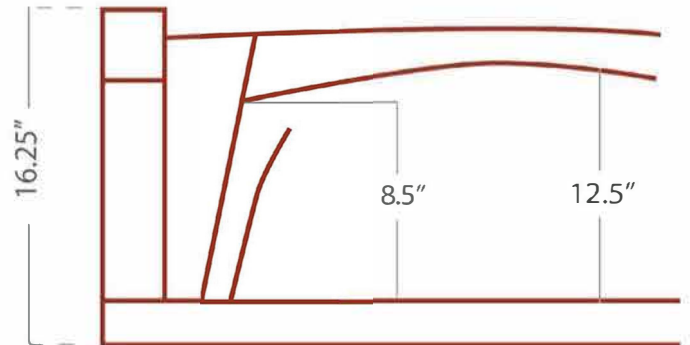
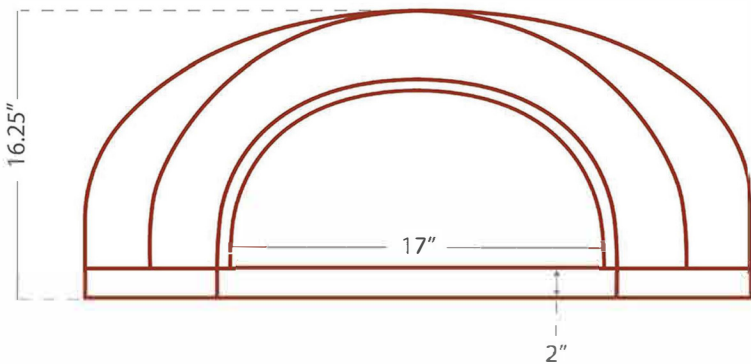
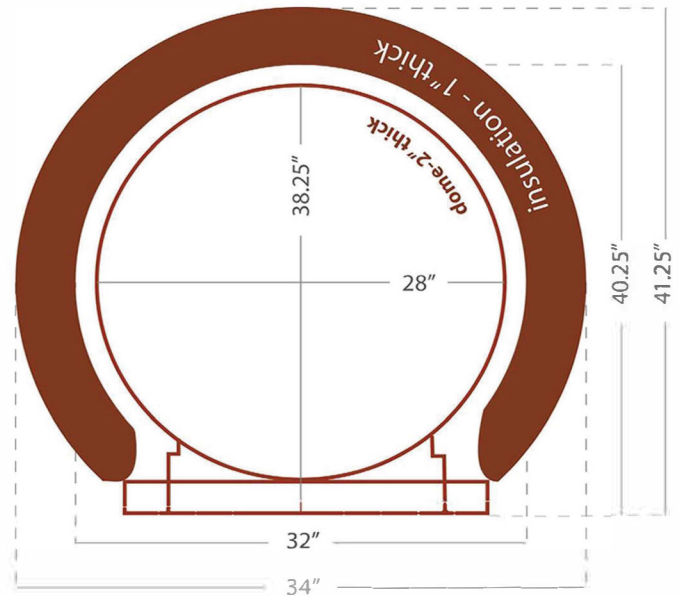
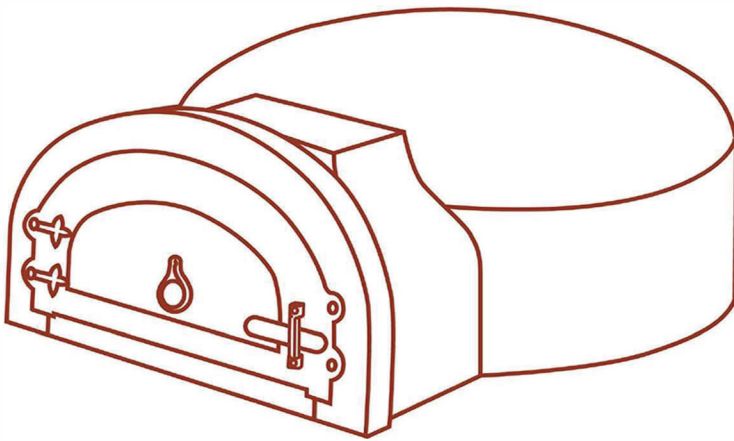

CHICAGO BRICK OVEN