

TIMELESS INSTRUMENTS

CAPACITIVE LEVEL SENSORS

USER MANUAL

rev. AA



EN

DE

IT

FR





ES

PT

CONTENT

- Safety Information.....3**
 - Safety During Installation.....3
 - Safety After Installation.....4
 - Electrical Connection4
- Mechanical Installation 5**
 - N02-240-40X5
 - N02-240-802 and -90X6
- Electrical Installation 8**
 - Connection to Engine Box8
 - Connection to TFT Displays.....9
 - Connection to ViewLine 52mm Gauges.....11
 - Alarm Connection12
- Calibration..... 13**
 - N02-240-40X13
 - N02-240-802 and 90X13
- Technical Data.....14**
- Accessories14**

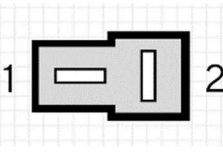
This manual covers all three types of capacitive water level sensors with analog output signal. This applies to the following sensors:

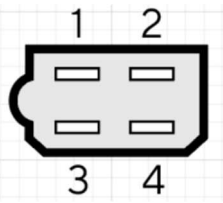
Sensor	Type	Connection	Article No.	Length [mm]
Fresh Water			N02-240-402	80-600
Fresh Water			N02-240-404	600-1200
Fresh Water			N02-240-406	1200-1500
Fresh Water			N02-240-802	80-600
Waste Water			N02-240-902	200-600
Waste Water			N02-240-904	600-1200
Waste Water			N02-240-906	1200-1500

SAFETY INFORMATION

WARNING

- No smoking! No open fire or heat sources!
- The product was developed, manufactured, and inspected according to the basic safety requirements of EC Guidelines and state-of-the-art technology.
- The instrument is designed for use in grounded vehicles and machines as well as in pleasure boats, including non-classified commercial shipping.
- Use our product only as intended. Use of the product for reasons other than its intended use may lead to personal injury, property damage or environmental damage. Before installation, check the vehicle documentation for vehicle type and any possible special features!
- Use the assembly plan to learn the location of the fuel/hydraulic/compressed air and electrical lines!
- Note possible modifications to the vehicle, which must be considered during installation!
- To prevent personal injury, property damage or environmental damage, basic knowledge of motor vehicle/shipbuilding electronics and mechanics is required.
- Make sure that the engine cannot start unintentionally during installation!
- Modifications or manipulations to veratron products can affect safety. Consequently, you may not modify or manipulate the product!
- When removing/installing seats, covers, etc., ensure that lines are not damaged and plug-in connections are not loosened!
- Note all data from other installed instruments with volatile electronic memories.

SAFETY DURING INSTALLATION

- During installation, ensure that the product's components do not affect or limit vehicle functions. Avoid damaging these components!
- Only install undamaged parts in a vehicle!
- During installation, ensure that the product does not impair the field of vision and that it cannot impact the driver's or passenger's head!
- A specialized technician should install the product. If you install the product yourself, wear appropriate work clothing. Do not wear loose clothing, as it may get caught in moving parts. Protect long hair with a hair net.
- When working on the on-board electronics, do not wear metallic or conductive jewelry such as necklaces, bracelets, rings, etc.
- If work on a running engine is required, exercise extreme caution. Wear only appropriate work clothing as you are at risk of personal injury, resulting from being crushed or burned.
- Before beginning, disconnect the negative terminal on the battery, otherwise you risk a short circuit. If the vehicle is supplied by auxiliary batteries, you must also disconnect the negative terminals on these batteries! Short circuits can cause fires, battery explosions and damages to other electronic systems. Please note that when you disconnect the battery, all volatile electronic memories lose their input values and must be reprogrammed.
- If working on gasoline boat motors, let the motor compartment fan run before beginning work.
- Pay attention to how lines and cable harnesses are laid so that you do not drill or saw through them!
- Do not install the product in the mechanical and electrical airbag area!
- Do not drill holes or ports in load-bearing or stabilizing stays or tie bars!
- When working underneath the vehicle, secure it according to the specifications from the vehicle manufacturer.
- Note the necessary clearance behind the drill hole or port at the installation location. Required mounting depth: 65 mm.
- Drill small ports; enlarge and complete them, if necessary, using taper milling tools, saber saws, keyhole saws or files. Deburr edges. Follow the safety instructions of the tool manufacturer.
- Use only insulated tools, if work is necessary on live parts.
- Use only the multimeter or diode test lamps provided, to measure voltages and currents in the vehicle/machine or boat. Use of

SAFETY INFORMATION

conventional test lamps can cause damage to control units or other electronic systems.

- The electrical indicator outputs and cables connected to them must be protected from direct contact and damage. The cables in use must have enough insulation and electric

strength and the contact points must be safe from touch.

- Use appropriate measures to also protect the electrically conductive parts on the connected consumer from direct contact. Laying metallic, uninsulated cables and contacts is prohibited.

SAFETY AFTER INSTALLATION

- Connect the ground cable tightly to the negative terminal of the battery.
- Reenter/reprogram the volatile electronic memory values.

- Check all functions.
- Use only clean water to clean the components. Note the Ingress Protection (IP) ratings (IEC 60529).

ELECTRICAL CONNECTION

- Note cable cross-sectional area!
- Reducing the cable cross-sectional area leads to higher current density, which can cause the cable cross-sectional area in question to heat up!
- When installing electrical cables, use the provided cable ducts and harnesses; however, do not run cables parallel to ignition cables or to cables that lead to large electricity consumers.
- Fasten cables with cable ties or adhesive tape. Do not run cables over moving parts. Do not attach cables to the steering column!
- Ensure that cables are not subject to tensile, compressive or shearing forces.
- If cables are run through drill holes, protect them using rubber sleeves or the like.
- Use only one cable stripper to strip the cable. Adjust the stripper so that stranded wires are not damaged or separated.
- Use only a soft soldering process or commercially available crimp connector to solder new cable connections!

- Make crimp connections with cable crimping pliers only. Follow the safety instructions of the tool manufacturer.
- Insulate exposed stranded wires to prevent short circuits.
- Caution: Risk of short circuit if junctions are faulty or cables are damaged.
- Short circuits in the vehicle network can cause fires, battery explosions and damages to other electronic systems. Consequently, all power supply cable connections must be provided with weldable connectors and be sufficiently insulated.
- Ensure ground connections are sound.
- Faulty connections can cause short circuits. Only connect cables according to the electrical wiring diagram.
- If operating the instrument on power supply units, note that the power supply unit must be stabilized and it must comply with the following standard: DIN EN 61000, Parts 6-1 to 6-4.

MECHANICAL INSTALLATION

N02-240-40X

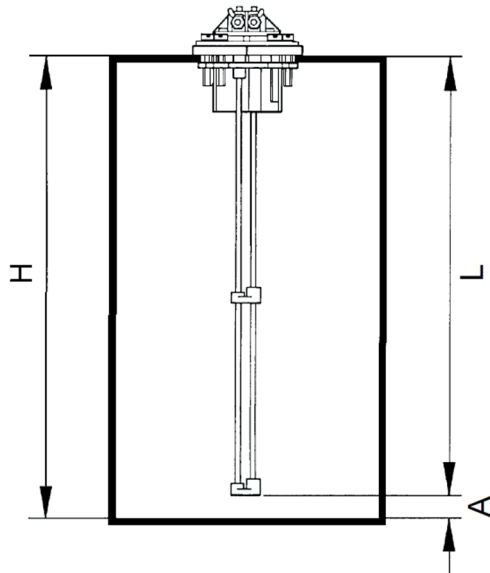

A = 10-15mm

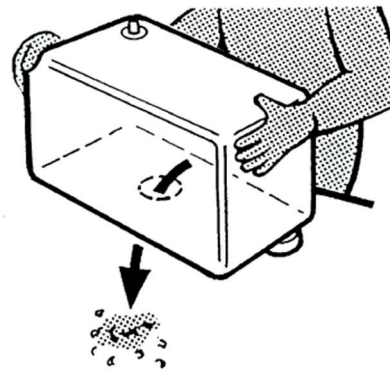
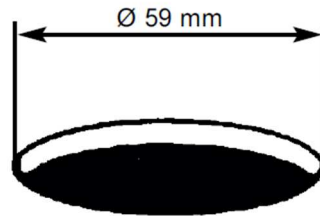

Create a hole with a diameter of 59mm.

First drill small holes at the installation apertures. Use tapered drills, compass saws, fretsaws or files to enlarge and complete the hole. Deburr the edges. The safety instructions of the hand tool manufacturer must be observed.

Clean the tank of residue from drilling, filing and sawing. When installation is finished, refill the water tank with fresh water.

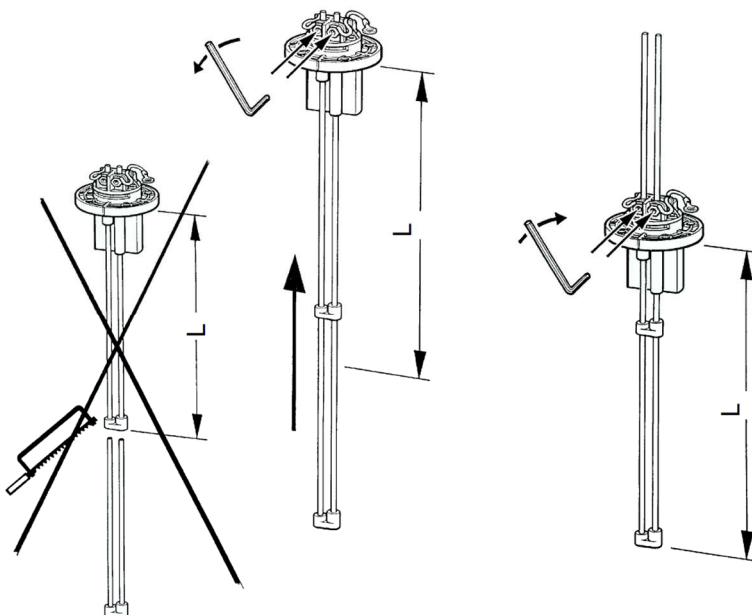

Do only shorten the rods from the top side.

The shortened rods must not be removed during the installation at any time, as the gaskets may be damaged during reinstallation of the rods.

Do not damage the surface of the enameled round rod.

MECHANICAL INSTALLATION

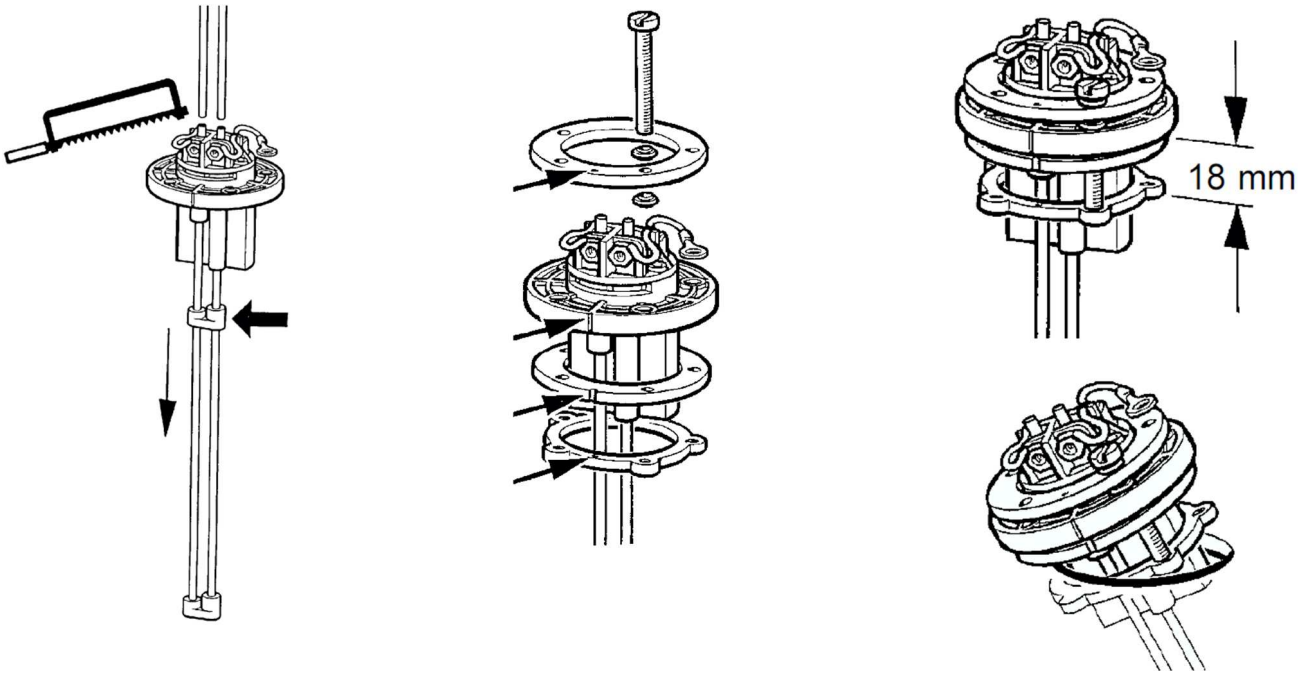

After shortening the rods, readjust the clamp to the middle of the new height.
 Prepare the three rings in the right order (soft rubber seal under the sensor). Make sure, the marks are aligned.
 Insert the sensor into the hole in the tank and only after that, insert the other screws.

N02-240-802 AND -90X

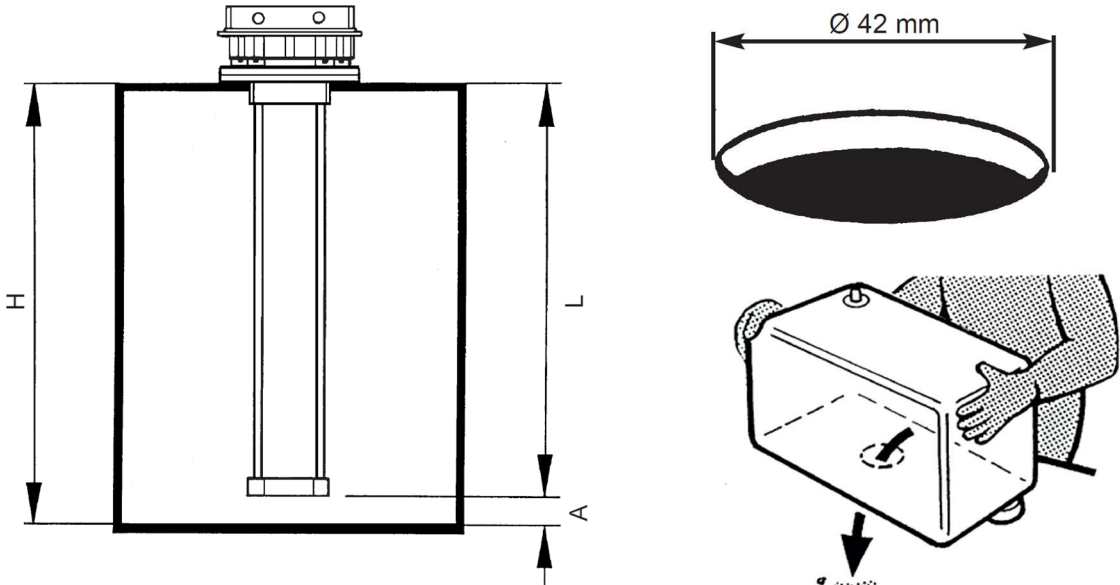

A = 10-15mm

Create a hole with a diameter of 42mm.
 First drill small holes at the installation apertures. Use tapered drills, compass saws, fretsaws or files to enlarge and complete the hole. Deburr the edges. The safety instructions of the hand tool manufacturer must be observed.
 Clean the tank of residue from drilling, filing and sawing. When installation is finished, refill the water tank with fresh water.

MECHANICAL INSTALLATION

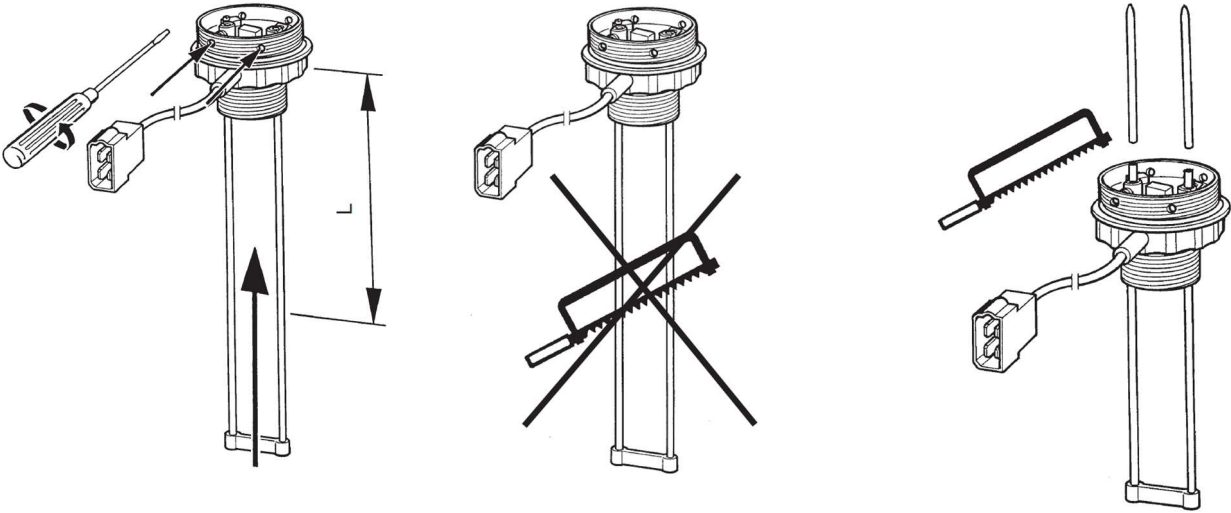

Loosen the screws in order to adjust the length of the rods.

Do only shorten the rods from the top side.

The shortened rods must not be removed during the installation at any time, because the gaskets may be damaged during the reinstallation.

Do not damage the surface of the enameled round rods.

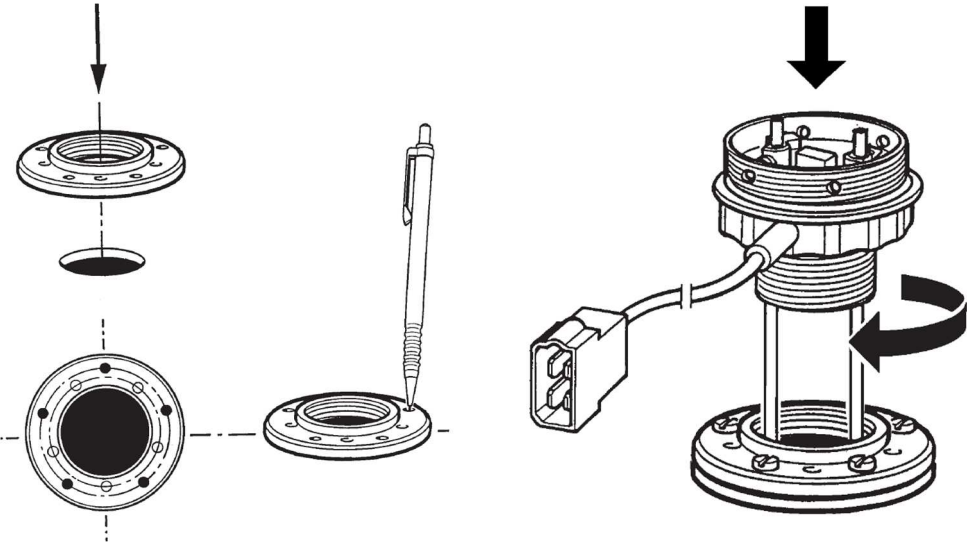

Use the flange to mark the placement of the drill holes.

Place the soft rubber seal between the flange and the tank.

When the flange is mounted on the tank, screw in the sensor from the top.

ELECTRICAL INSTALLATION

CONNECTION TO ENGINE BOX

The Veratron EngineBox offers two capacitive sensor inputs. They are located on the pins 14 (brown/white) and 30 (brown).

N02-240-40X

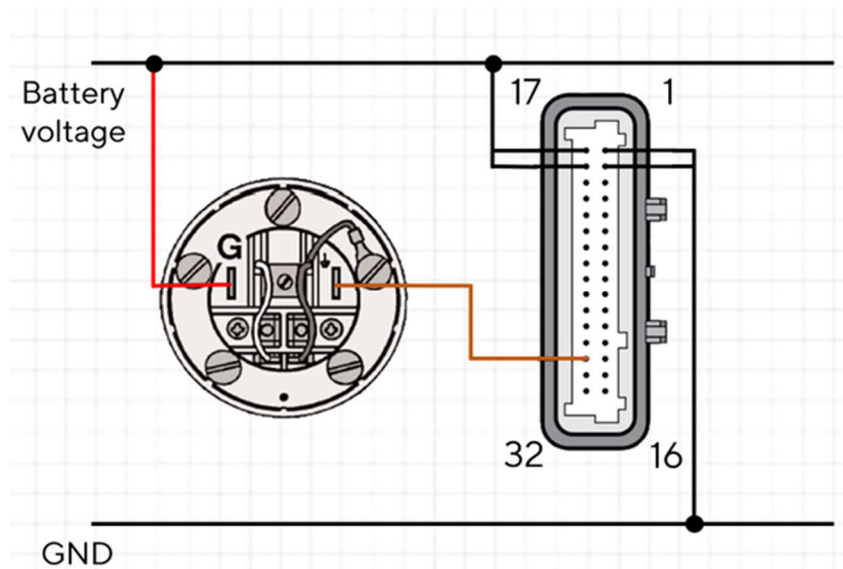

Use the black wire with the ring connector for grounding on metal tanks.

N02-240-802

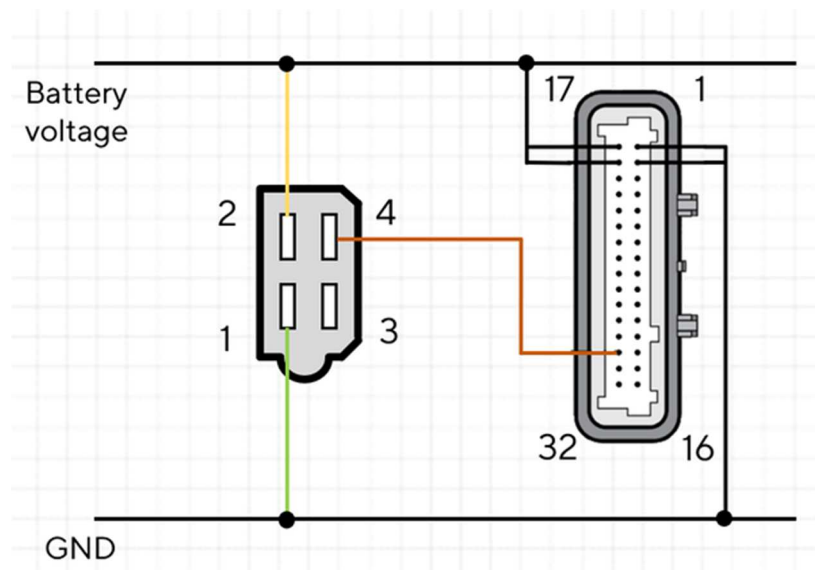

N02-240-90X

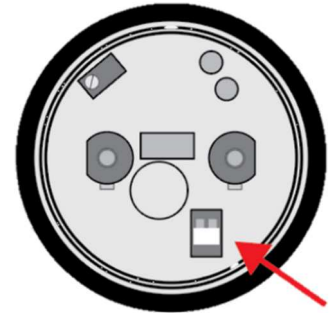
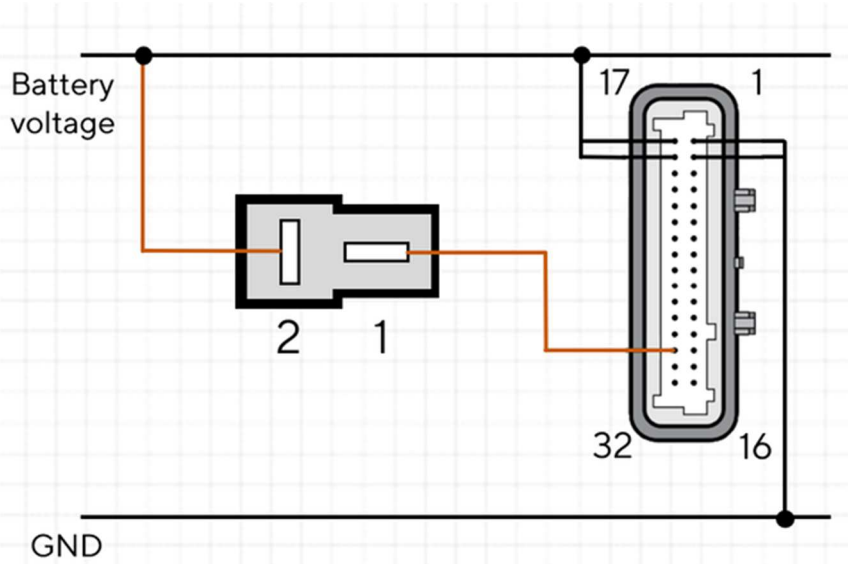

Make sure the switch heads towards the outside of the sensor.

CONNECTION TO TFT DISPLAYS

Every OceanLink TFT display and VMH 70 is designed with one or two capacitive sensor inputs. They are located on (Engine1 connector) pins 11 (light blue) and 12 (violet).

N02-240-40X

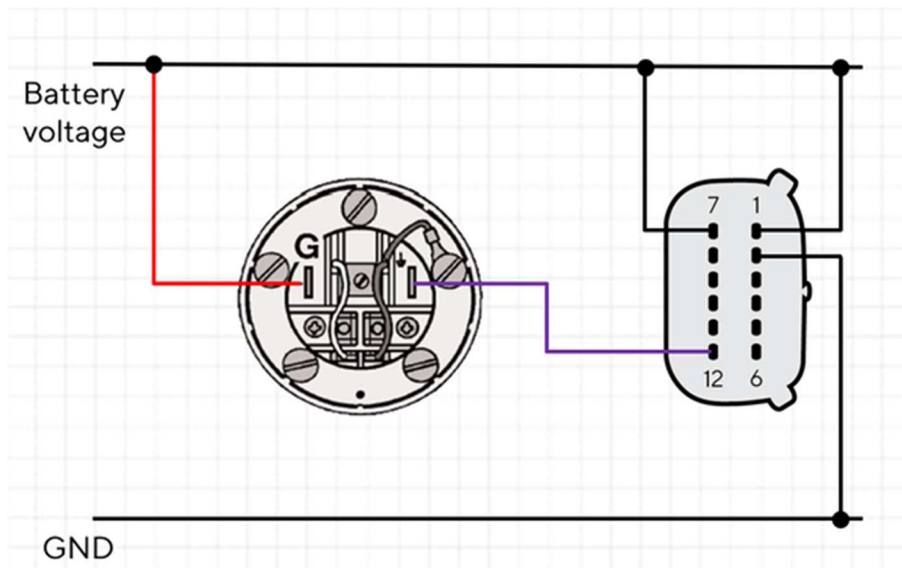

Use the black wire with the ring connector for grounding on metal tanks.

N02-240-802

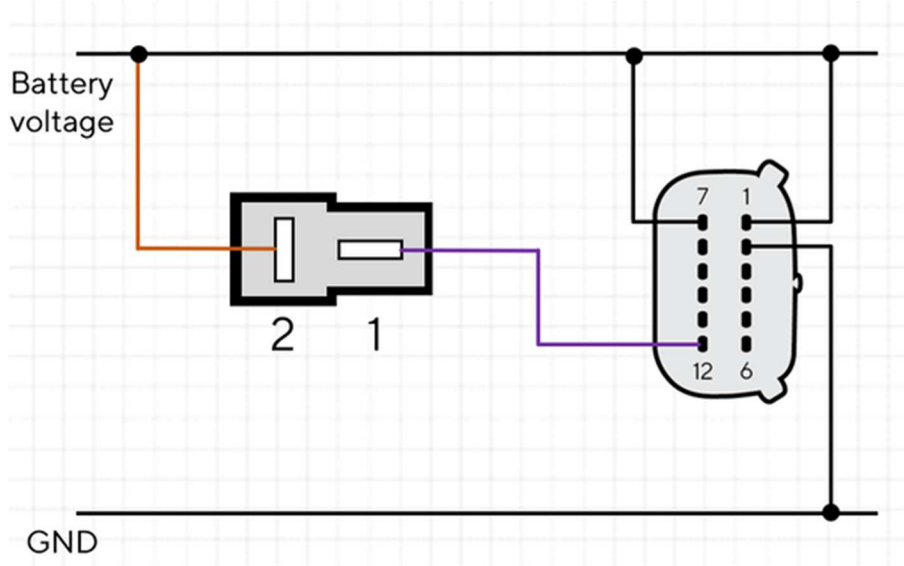

N02-240-90X

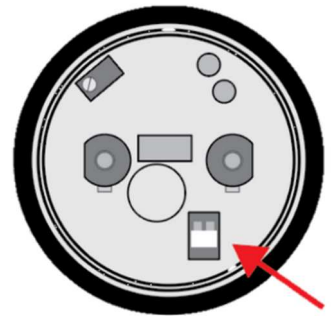
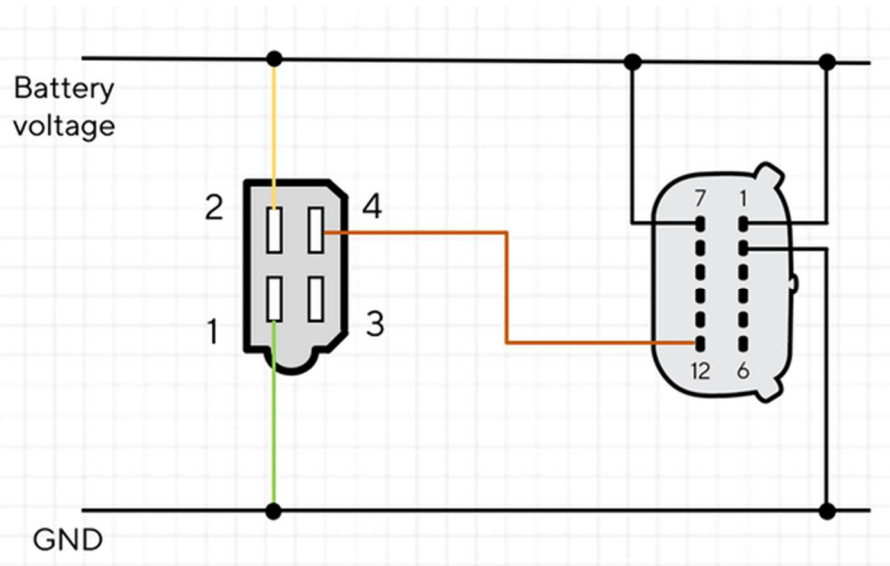

Make sure the switch heads towards the outside of the sensor.

CONNECTION TO VIEWLINE 52MM GAUGES

Pin No	Color	Description
1	Red	Ignition plus
2	Black	Ground
3	Black / Blue	Sensor ground
4	Brown	Battery power (12/24V)
5	Green	Sensor Signal
6	Blue / Red	Illumination
7	Yellow / Black	Warning LED ground
8	Yellow / Red	Warning LED plus

Designations in the schematics:

- 30 - Battery Plus (12/24V)
- 15 - Ignition
- 58 - Illumination signal
- 31 - Ground
- F1 - Fuse

Fresh Water Gauge to N02-240-40X

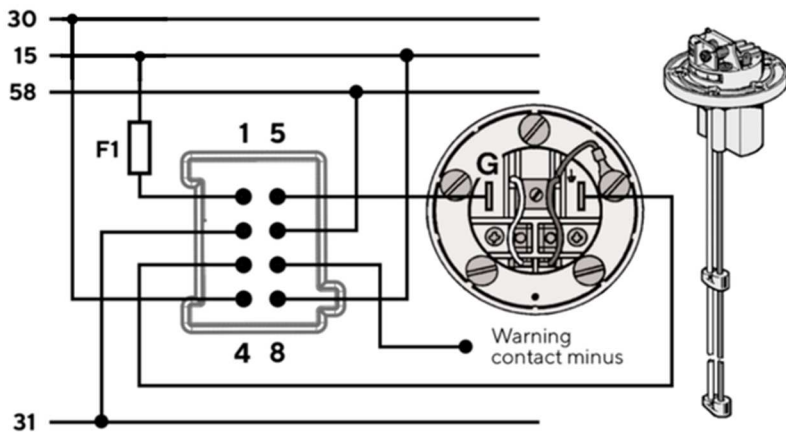

Waste Water Gauge to N02-240-90X

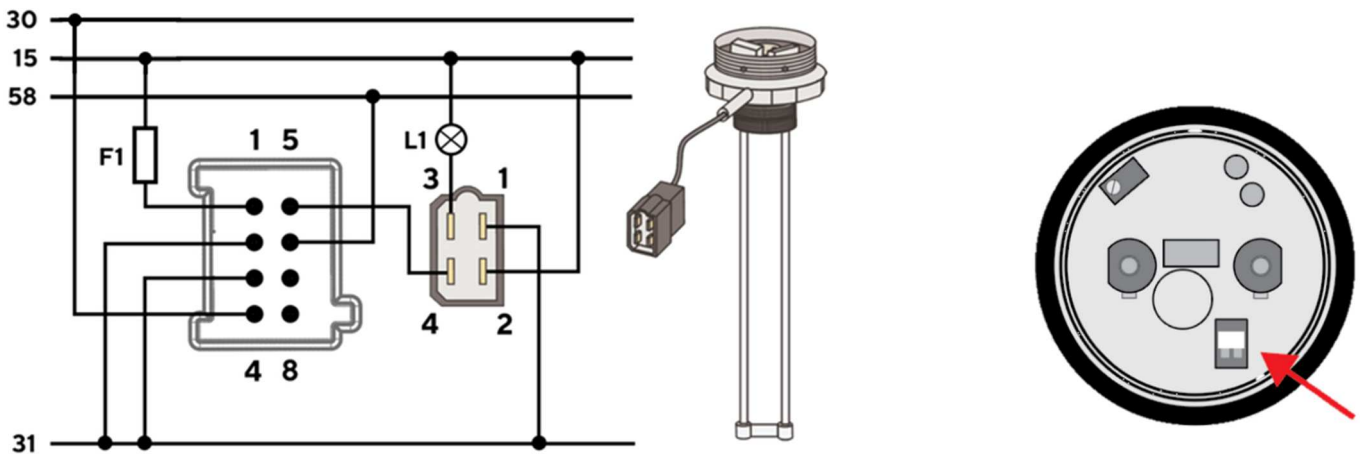

Make sure the switch heads towards the center of the sensor.

ALARM CONNECTION

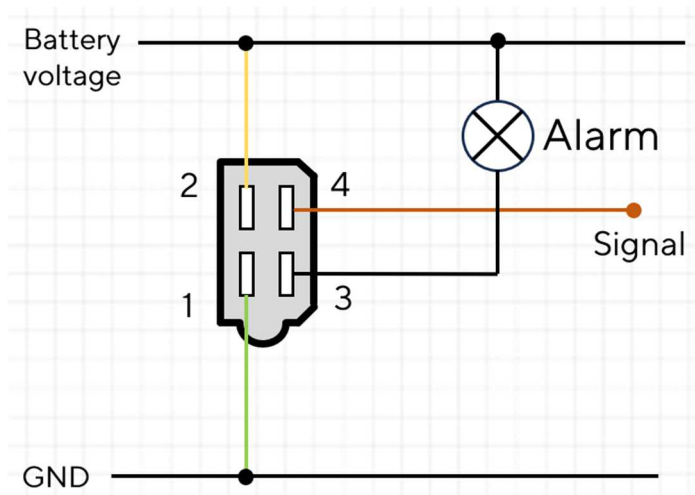

The -90X-Sensors provide an alarm output.

If the alarm threshold is reached, pin 3 will be connected to ground. (Open collector output)

The maximum current is 1.0 A.

CALIBRATION

N02-240-40X

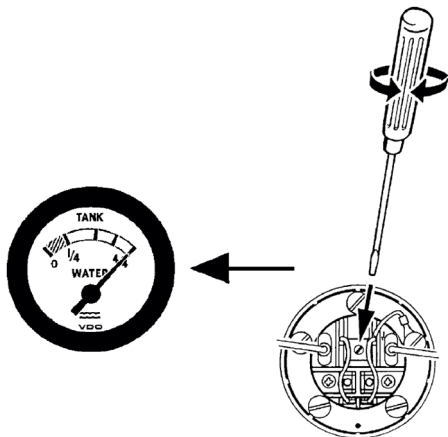

To calibrate the sensor, fill the tank completely.
Turn the potentiometer until the gauge just reaches the upper limit of the scale.
The lower limit does not require any calibration.

N02-240-802 AND 90X

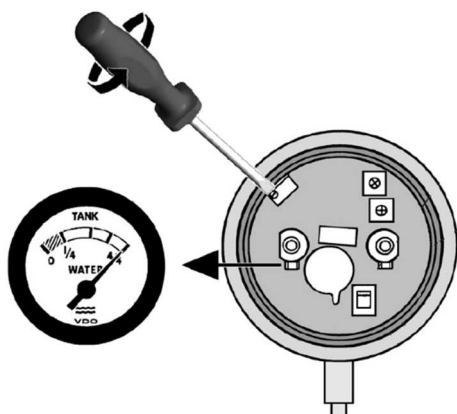

Make sure the switch is in the correct position depending on the instrument, that reads the signal. (See the according drawings in the chapter Electrical Installation > N02-240-90X.)

To calibrate the sensor, fill up the tank completely.
Turn the potentiometer on the sensor as displayed in the picture, until the level gauge just reaches the upper limit of the scale.

The lower limit does not require any calibration.

Alarm threshold (only on -90X variants)

With the two potentiometers P1 and P2 the threshold for the alarms can be changed or the alarms can be turned off completely.

The threshold for the low level alarm can be adjusted between 0 and 33%.

The threshold for the high level alarm can be adjusted between 66 and 100%

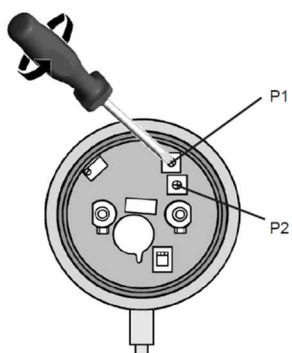

P1 – Low Alarm

If the Low alarm is not needed, carefully turn P1 clockwise to the limit.

P2 – High Alarm

If the High alarm is not needed, carefully turn P2 counterclockwise to the limit.

TECHNICAL DATA

	-40X	-802	-90X
Fluid	Fresh water	Fresh water	Waste water
Length	80-1500 mm	80-600 mm	200-1500 mm
Nominal Voltage	12V / 24V		
Output signal	4 - 20 mA	4 - 20 mA	4 - 20 mA Alarm (1.0 A max)
Alarm Range	-	-	0-33% low level 66-100% high level
Installation hole	59 mm	42 mm	42 mm

ACCESSORIES

Description	Part Number
Sealing Kit for Waste Water Sensor	N05-016-930
Sealing Kit for Water Capacitive Sensor	N05-001-370

veratron AG
Industriestrasse 18
9464 Rüthi, Switzerland

T +41 71 7679 111
info@veratron.com
veratron.com

Any distribution, translation, or reproduction, partial or total, of the document is strictly prohibited unless with prior authorization in writing from veratron AG, except for the following actions:

Printing the document in its original format, totally or partially.
Copying contents without any modifications and stating veratron AG as copyright owner.

Veratron AG reserves the right to make modifications or improvements to the relative documentation without notice.

Requests for authorization, additional copies of this manual or technical information on the latter, must be addressed to veratron AG.