

MGN9H Carriage

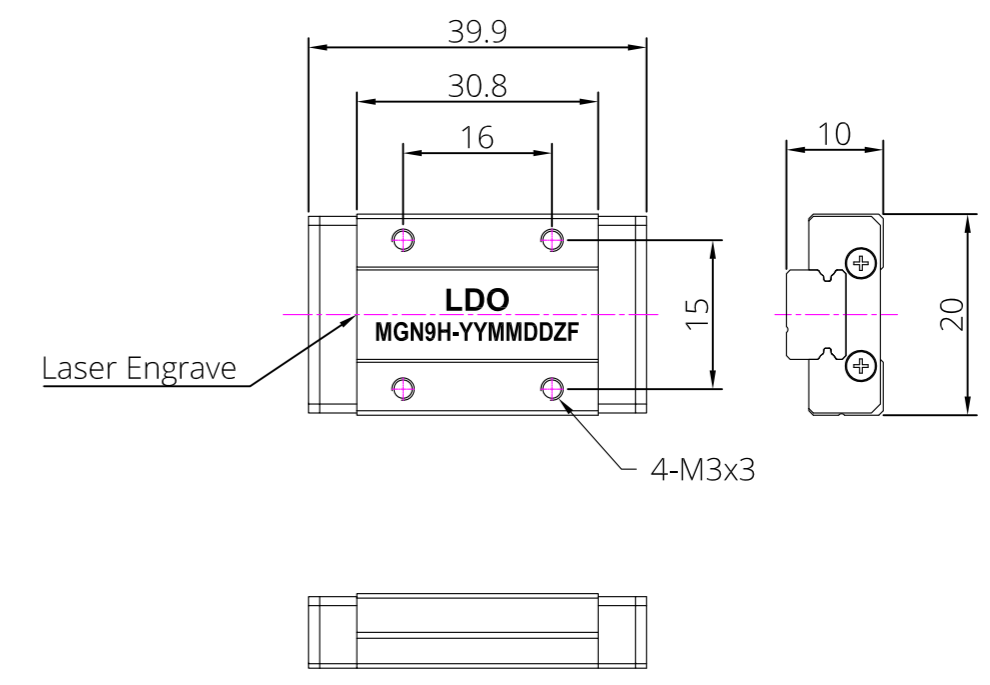

MGN9C Carriage

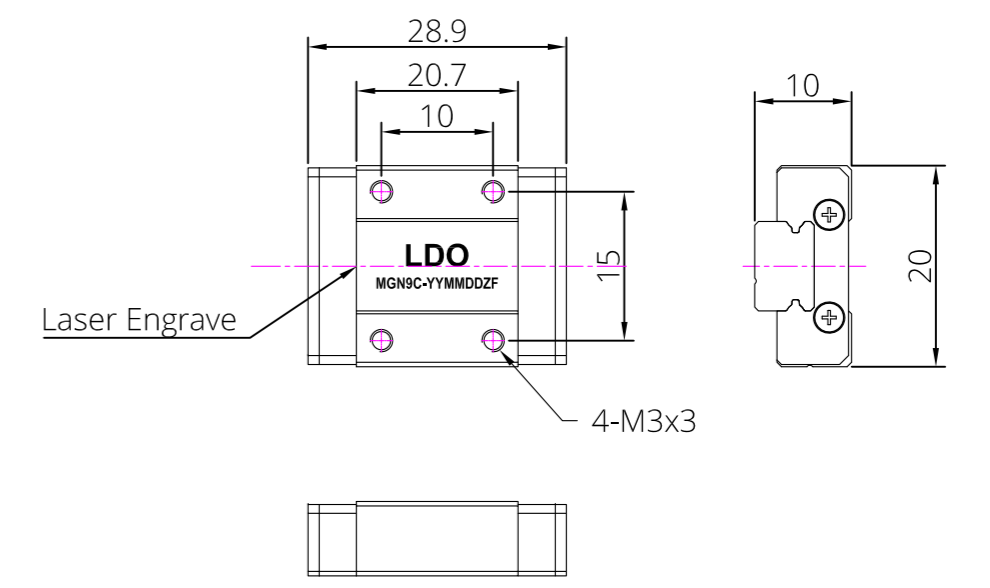

- Notes:
- It is a good idea to replace the anti-corrosion oil that comes on the linear rail with lithium based grease such as HIWIN G05 or similar. Recommend re-lubricating every 100km, or every 500,000 cycles or so. Lubrication provides the following functions:
 - Reduce the rolling friction and surface wear of the rail/carriage.
 - Anti-corrosion
 - Avoid removing the carriage from the rail if possible. Always use the black plastic insert (included) if the carriage needs to be removed, so the balls stay in the carriage.
 - Accuracy class C
 - Dimension tolerance of height and width: ± 40 microns
 - Maximum travel distance error: ± 17 microns per 300~400mm and ± 23 microns per 1000mm
 - Preload: Light Clearance Class, 4um MAX
 - Do not disassemble the carriages.
 - Avoid bumping/dropping the rail or carriage, doing so will affect the accuracy.
 - As some parts of the carriage are plastic, the maximum working temperature for the linear rail is 100°C.
 - Rail material: Gr15 bearing steel; Ball material: GCr15 bearing steel, Endcap material: Nylon + Glass Fiber. Ball size: 2.000mm.

A		NEW RELEASE		Xu SD	J.B.	9/12/20
REV.	ECN NO.	DESCRIPTION	MADE BY	APPR. BY	DATE	
DRAWN BY		CHECKED BY	APPR. BY	DATE	FACTORY CODE	SHEET NO.
Xu SD		J.B.	J.B.	9/12/20		1/1

	VIEW		LDO Motors Co., Ltd. Part NO.			
	SCALE			MGN LINEAR RAIL LDO-MGN9H/C		
DRAWN BY		CHECKED BY	APPR. BY	DATE	FACTORY CODE	SHEET NO.
Xu SD		J.B.	J.B.	9/12/20		1/1