

# TN5138 - KN5138

PARAMOTORE SPECIFICO - SPECIFIC ENGINE GUARD - PARE-CARTER SPECIFIQUE - SPEZIFISCHER STURZBÜGEL - DEFENSA DE MOTOR ESPECÍFICA - PARAMOTOR ESPECÍFICO

## BMW S1000 XR (2020)

N°	Descrizione/Description	Caratteristiche/Features	Codice/Code	Quantità/Quantity
1	Paramotore - Engine Guard Pare-carter - Sturzbuegel Defensa De Moto - Paramotor	-	TN5138DXV TN5138SXV	2 (Right:Left)
2	Vite - Screw - Vis - Schraube Tornillo - Parafuso	TBEI M8x45	845TBEI	1
3	Vite - Screw - Vis - Schraube Tornillo - Parafuso	TCE M10x30	1030TCE	4
4	Vite - Screw - Vis - Schraube Tornillo - Parafuso	TEF M10x65	1065TEF	2
5	Rondella - Washer - Rondelle - Scheibe Arandela - Arruela	Foro Ø8,5mm / Esterno Ø20mm Sp. 2mm	820RON	1
6	Rondella - Washer - Rondelle - Scheibe Arandela - Arruela	Foro Ø10mm / Esterno Ø20mm Sp. 2mm	10RON	2
7	Distanziale - Spacer - Entretoise - Distanzstueck Distanciadador - Espaçador	-	V1023	2
8	Distanziale - Spacer - Entretoise - Distanzstueck Distanciadador - Espaçador	Ø16x12 Foro 12mm	C16L12F12FET	1
9	Distanziale - Spacer - Entretoise - Distanzstueck Distanciadador - Espaçador	Ø20x8 Foro 10,5mm	C20L8F10,5T	4
10	MOUSSE	L.140mm	MOUSSE3	1
11	Distanziale - Spacer - Entretoise - Distanzstueck Distanciadador - Espaçador	-	V1094	2
12	Rondella In Gomma - Rubber Washer - Rondelle En Gomme Gummischeibe - Arandela De Goma - Arruela De Borracha	Foro Ø13,5/Esterno 25mm Sp.3mm	Z2500	2
13	Componenti Originali - Original Parts Parties Originales - Original Bauteile Componentes Originales - Componentes Originais	-	-	-

IT\_ Si raccomanda di fare eseguire il montaggio ad un meccanico qualificato.  
Nel caso in cui sulle viti originali sia presente del frenafili, ripristinarlo durante il montaggio dell'accessorio.

EN\_ We recommend fitting by a qualified mechanic.

If there is threadlocker on the original screws, use threadlocker when mounting the accessory.

DE\_ Wir empfehlen, dass die Montage von einem Fachmechaniker durchgeführt wird.

Falls sich auf den Originalschrauben Schraubensicherungsklebstoff befand, sollte dieser auch bei der Montage des Zubehörs wieder aufgetragen werden.

FR\_ Il est recommandé de faire le montage par un mécanicien qualifié.

Si du frein filet est présent sur les vis d'origine, l'appliquer également lors du montage de l'accessoire.

ES\_ Se recomienda realizar el montaje por un mecanico cualificado.

En caso de que el fijador de roscas se encuentre presente en los tornillos originales, colocarlo nuevamente en el montaje del accesorio.

PT\_ Recomendamos a fixação por um mecânico qualificado

Se houver trava rosca nos parafusos originais, inserir novamente durante a montagem do acessório.

ISTRUZIONI DI MONTAGGIO - MOUNTING INSTRUCTIONS  
INSTRUCTIONS DE MONTAGE - BAUANLEITUNG  
INSTRUCCIONES DE MONTAJE - INSTRUÇÕES DE MONTAGEM

# TN5138 - KN5138

PARAMOTORE SPECIFICO - SPECIFIC ENGINE GUARD - PARE-CARTER SPECIFIQUE - SPEZIFISCHER STURZBÜGEL - DEFENSA DE MOTOR ESPECÍFICA - PARAMOTOR ESPECÍFICO

## BMW S1000 XR (2020)

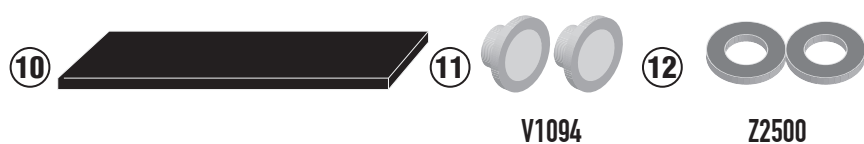
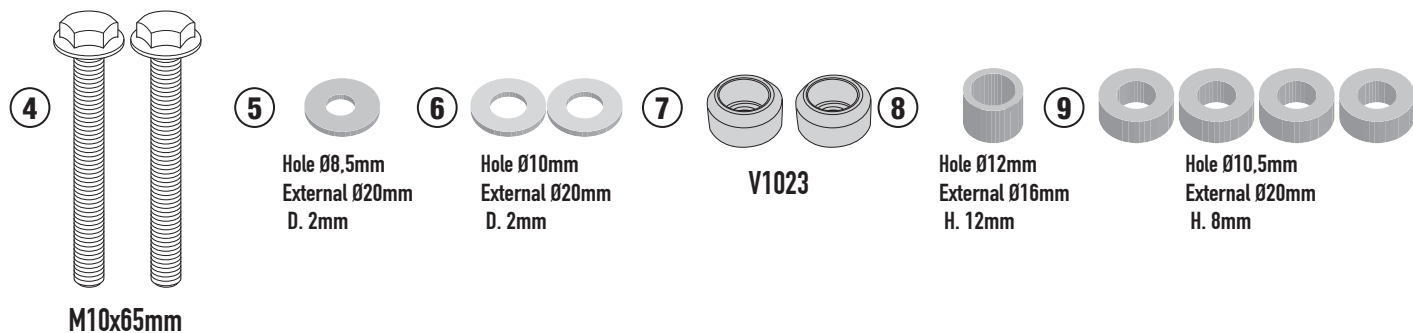
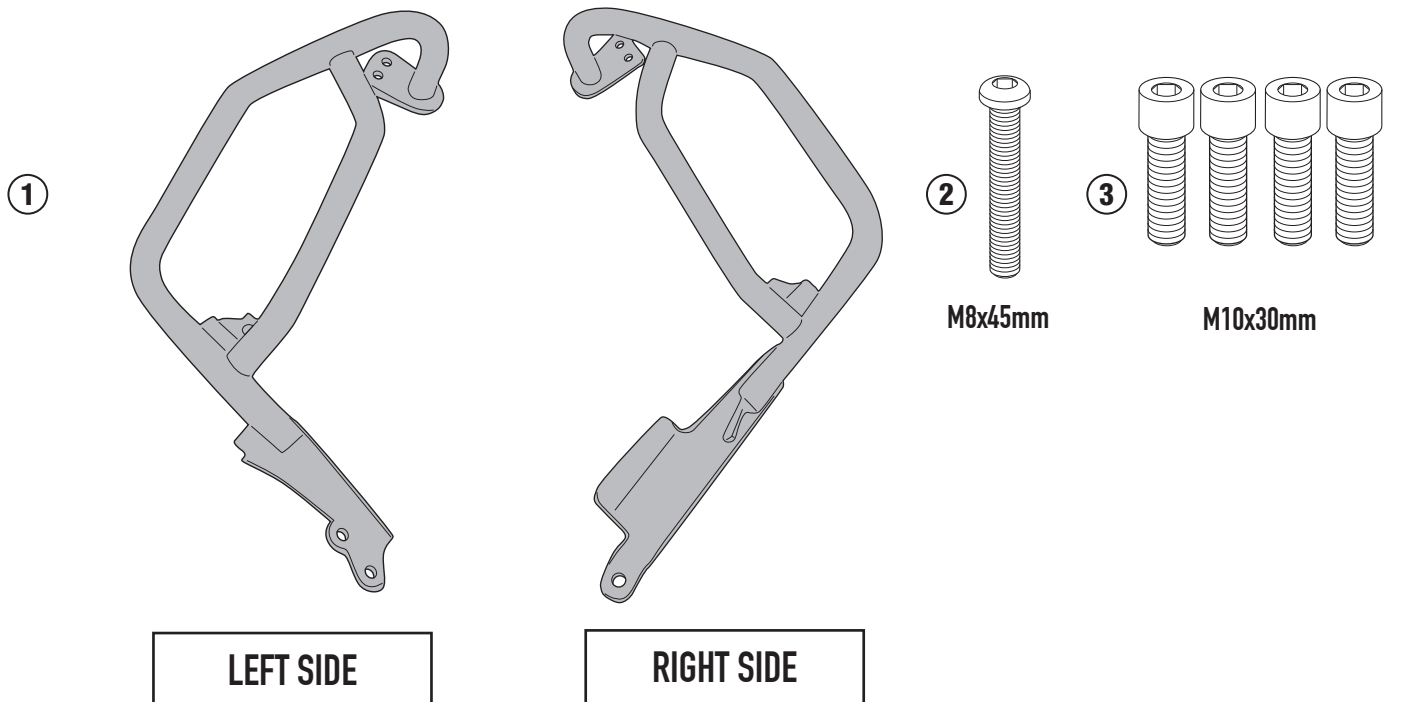

# TN5138 - KN5138

PARAMOTORE SPECIFICO - SPECIFIC ENGINE GUARD - PARE-CARTER SPECIFIQUE - SPEZIFISCHER STURZBÜGEL - DEFENSA DE MOTOR ESPECÍFICA - PARAMOTOR ESPECÍFICO

## BMW S1000 XR (2020)

### LEFT SIDE

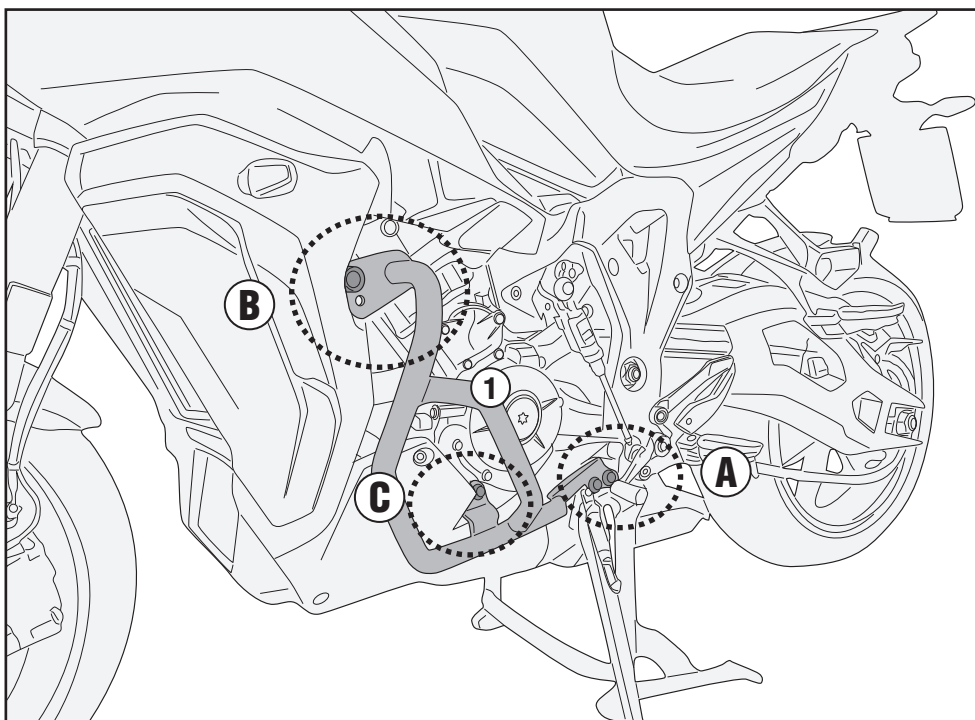

### MOUNT IN THE REAR SIDE

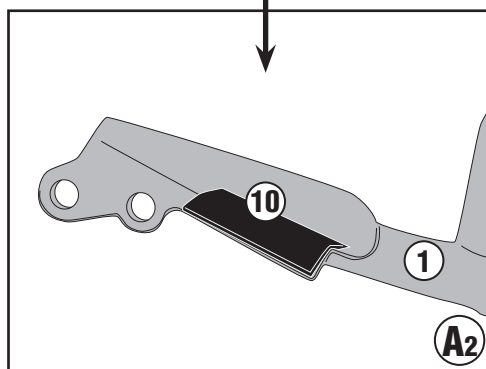
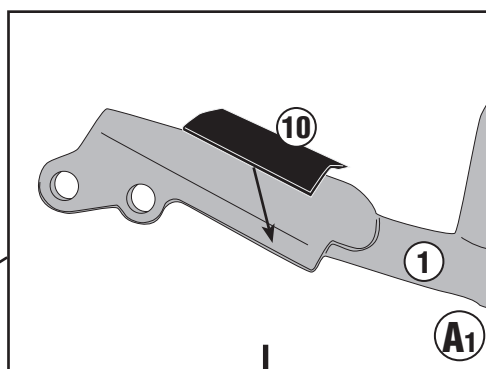
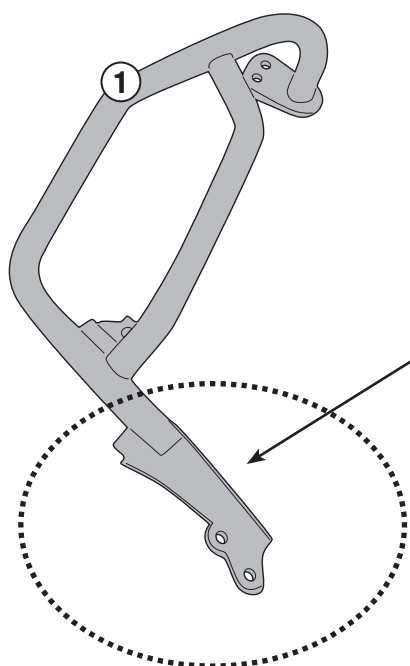

# TN5138 - KN5138

PARAMOTORE SPECIFICO - SPECIFIC ENGINE GUARD - PARE-CARTER SPECIFIQUE - SPEZIFISCHER STURZBÜGEL - DEFENSA DE MOTOR ESPECÍFICA - PARAMOTOR ESPECÍFICO

## BMW S1000 XR (2020)

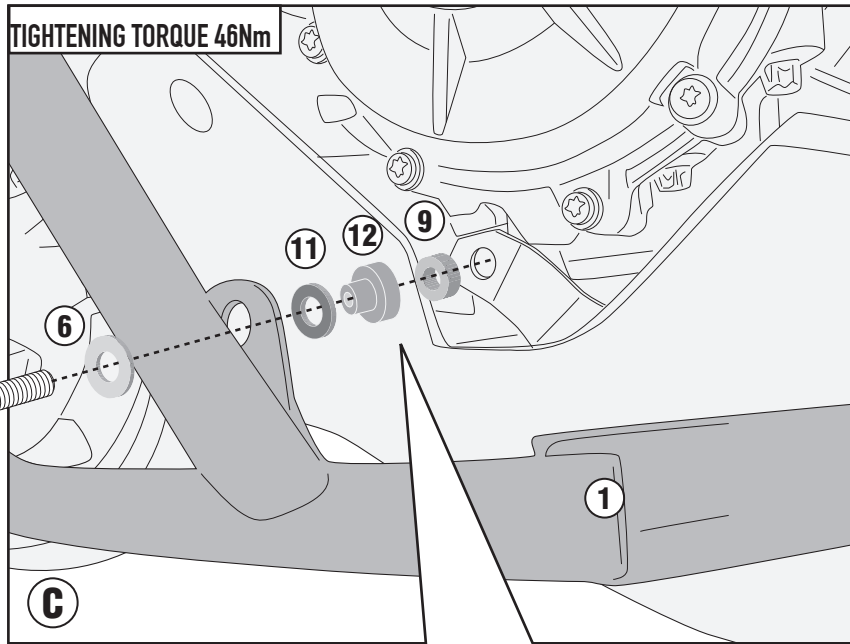
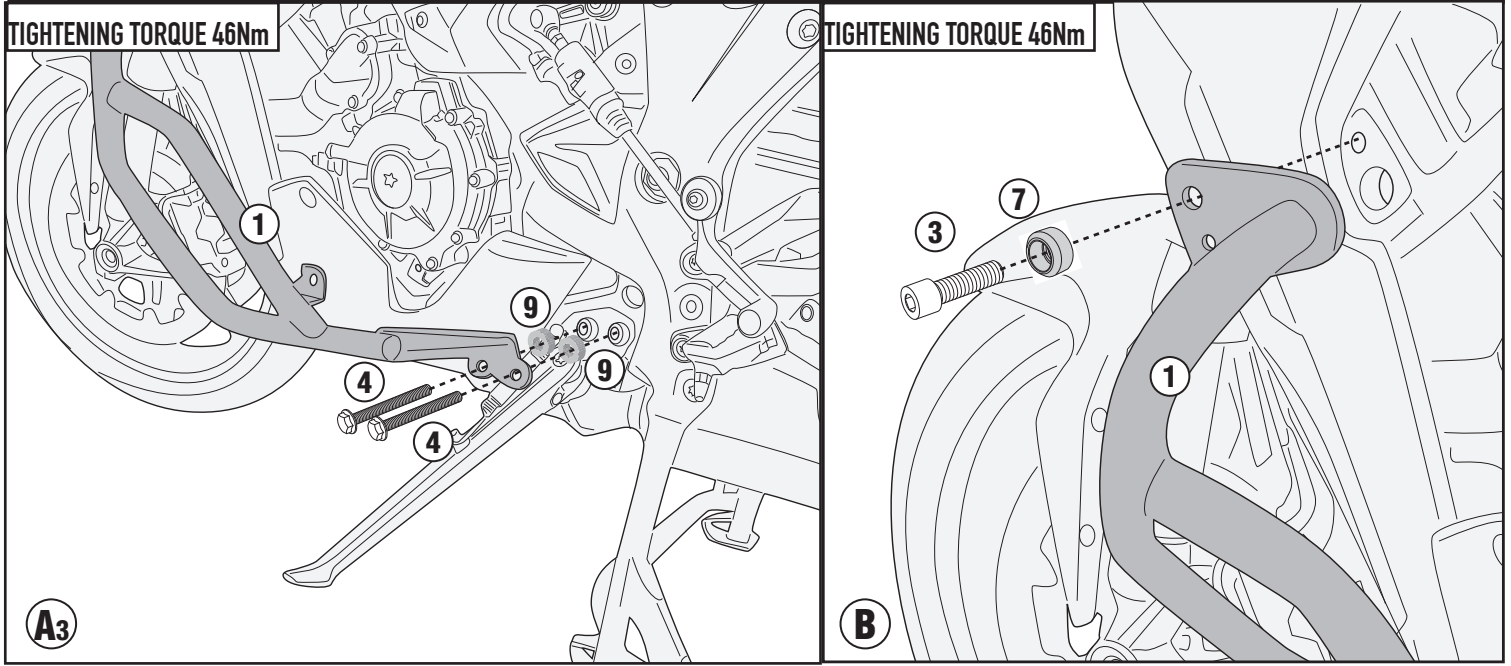

**!**  
 - ATTENZIONE AL VERSO DEL DISTANZIALE  
 - PAY ATTENTION TO THE DIRECTION OF THE SPACER  
 - ATTENTION AU SENS DE L'ENTRETOISE  
 - ACHTEN SIE AUF DIE RICHTUNG DES ABSTANDSHALTERS  
 - PRESTE ATENCIÓN A LA DIRECCIÓN DEL ESPACIADOR  
 - PRESTE ATENÇÃO NA DIREÇÃO DO ESPAÇADOR

1	11	12	9	13	

# TN5138 - KN5138

PARAMOTORE SPECIFICO - SPECIFIC ENGINE GUARD - PARE-CARTER SPECIFIQUE - SPEZIFISCHER STURZBÜGEL - DEFENSA DE MOTOR ESPECÍFICA - PARAMOTOR ESPECÍFICO

## BMW S1000 XR (2020)

### RIGHT SIDE

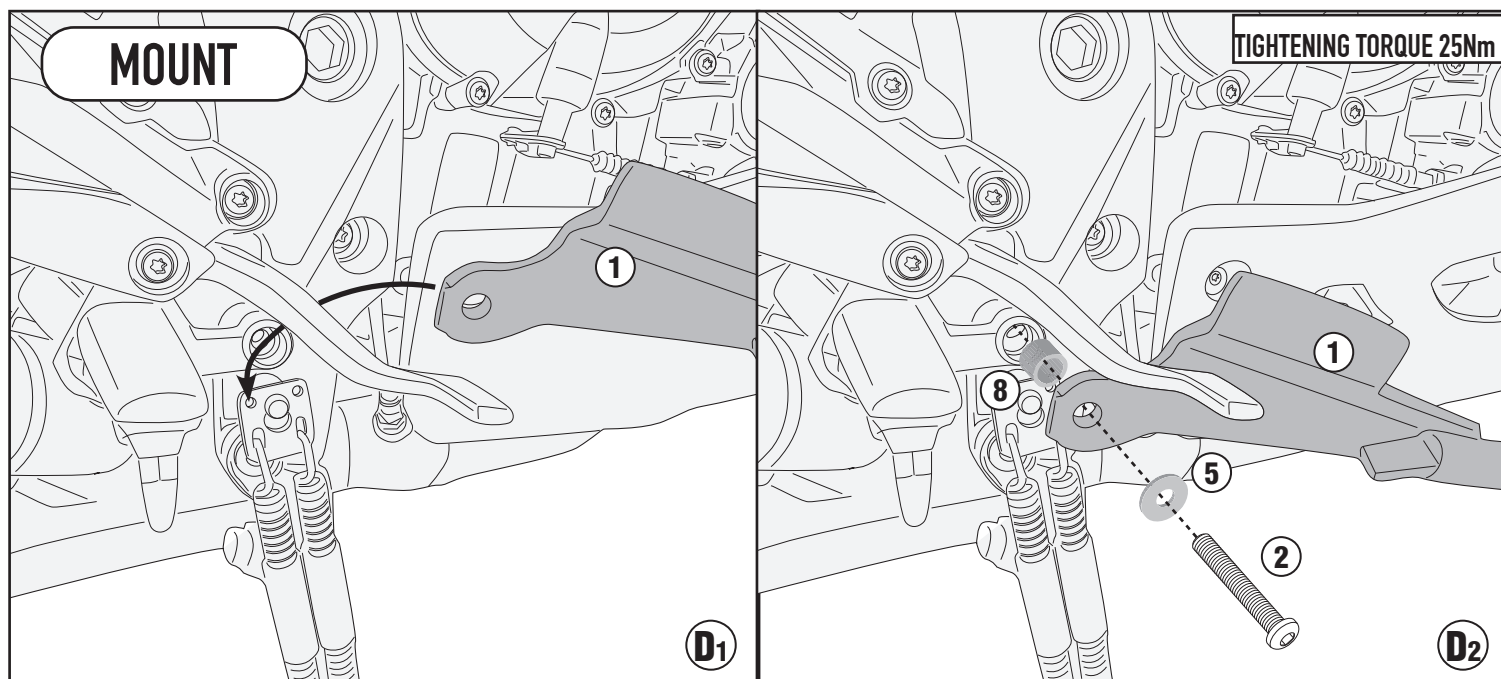
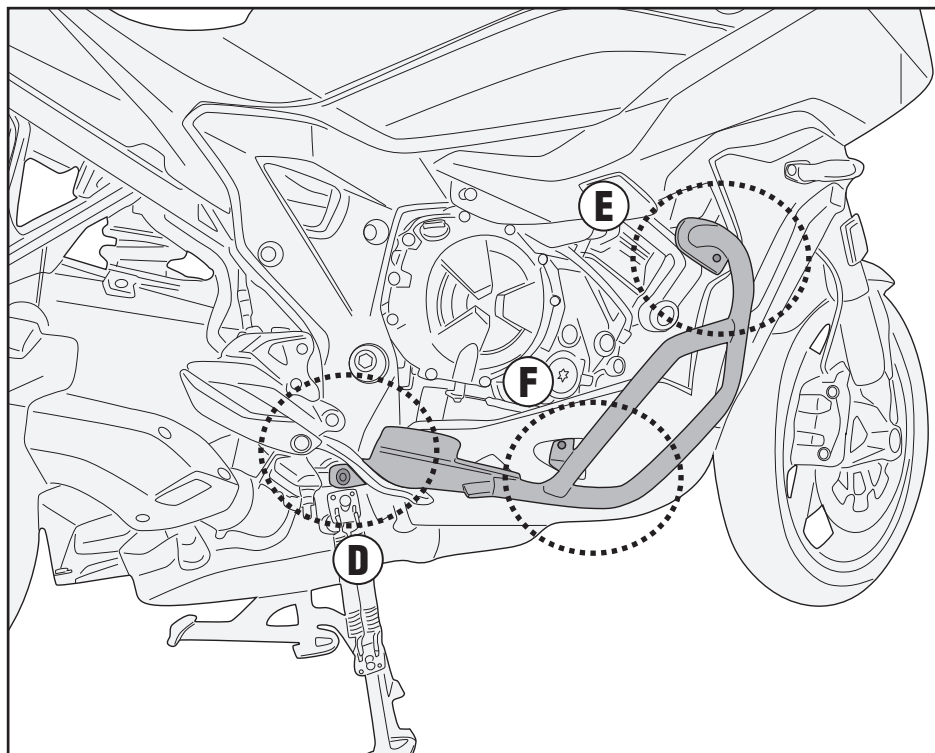

# TN5138 - KN5138

PARAMOTORE SPECIFICO - SPECIFIC ENGINE GUARD - PARE-CARTER SPECIFIQUE - SPEZIFISCHER STURZBÜGEL - DEFENSA DE MOTOR ESPECÍFICA - PARAMOTOR ESPECÍFICO

## BMW S1000 XR (2020)

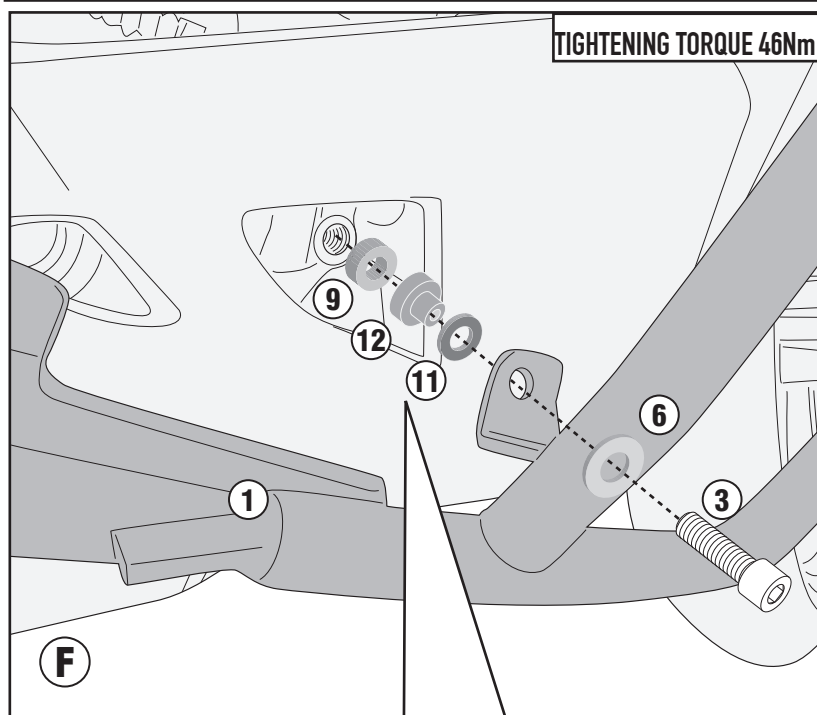
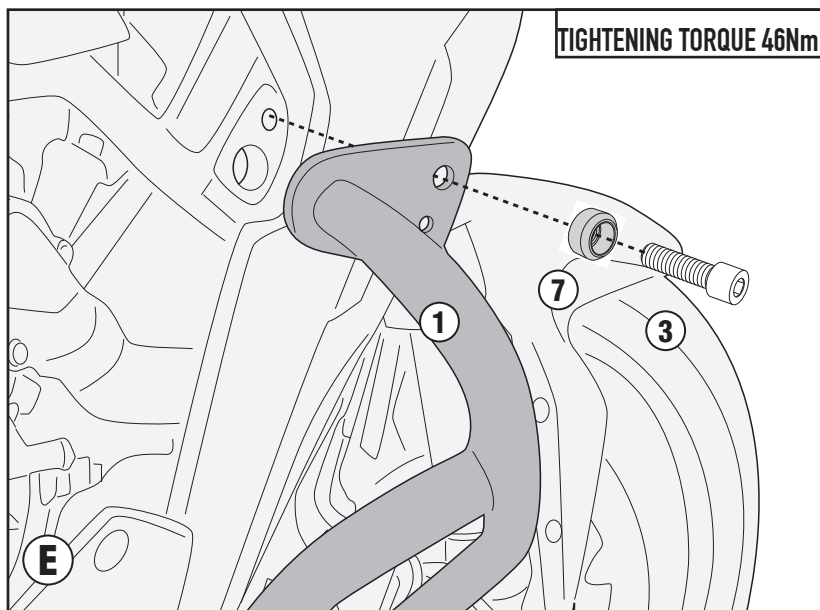

- ATTENZIONE AL VERSO DEL DISTANZIALE
- PAY ATTENTION TO THE DIRECTION OF THE SPACER
- ATTENTION AU SENS DE L'ENTRETOISE
- ACHTEN SIE AUF DIE RICHTUNG DES ABSTANDSHALTERS
- PRESTE ATENCIÓN A LA DIRECCIÓN DEL ESPACIADOR
- PRESTE ATENÇÃO NA DIREÇÃO DO ESPAÇADOR

