



T40

Electric Walkie Tugger

Improve safety and productivity by reducing the strain involved in the transport of common industrial carts.

TOWING CAPACITY

1800kg

EASY EXCHANGE Lithium Battery System

24v 20AH battery fits into on-board dock and external 110V 10A charger.

TRAVEL SPEED

Variable from 0 to 4.8 km/h empty
Variable from 0 to 3.2 km/h loaded

WEIGHT

283kg

TIRES / CASTERS

DRIVE

(2) 2x 250x85 Pneumatic rubber tires

Stability casters

(2) 1x 250x85 polyurethane

DRIVE

24-Volt DC 0.5 PS

S2 60 minute rated electric drive motor with heavy duty transaxle housing.

BRAKE

Electromagnetic brake.

CONTROLS & FEATURES

Ergonomic control head with (3) height adjustments accommodates different size operators. Wrap around hand guard, dual butterfly travel controls with infinitely variable forward and reverse travel control, reversing switch, key switch, battery discharge indicator and horn as standard equipment.

180 DEGREE ARTICULATING TOW ARM

Spring loaded tow arm articulates for easy turning and comes with both a pin style and frame grab tools for easy integration with many common industrial carts.



PERFORMANCE

Performance may be reduced depending on the type of cart being towed, cart wheel size and composition, integration of tow arm tools with cart providing adequate weight transfer, and other factors.

DUTY CYCLE

Revolutionary Easy Exchange Battery delivers up to 2 hours of continuous operation and can be fully charged within 2.5 hours. Optional extra batteries can be used to extend run time or to serve as a reliable back-up.

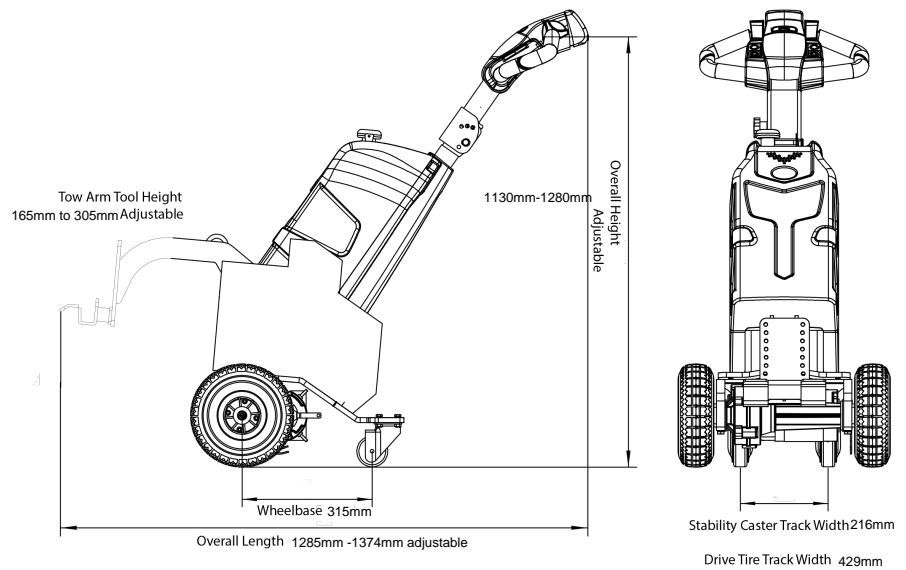

Maximum gradeability

3% Loaded
10% Unloaded

