



# T15

## Electric Walkie Tugger

### TOWING CAPACITY

680kg

### INTEGRAL BATTERY / CHARGER

Maintenance free 50AH batteries with 240 V smart charger @10A.

### TRAVEL SPEED

Variable from 0 to 5 km/h empty  
Variable from 0 to 4.5 km/h loaded

### WEIGHT

98kg

### TIRES / CASTERS

#### DRIVE

(2) 2x 250x85 Pneumatic rubber tires

#### Load

(2) 1x 250x85 polyurethane

### DRIVE

24-Volt DC 0.5 PS

S2 60 minute rated electric drive motor with heavy duty transaxle housing.

### BRAKE

Electromagnetic brake.

### CONTROLS & FEATURES

Ergonomic control head with (3) height adjustments accommodates different size operators. Wrap around hand guard, dual butterfly travel controls with infinitely variable forward and reverse travel control, reversing

switch, key switch, battery discharge indicator and horn as standard equipment.

### 180 DEGREE ARTICULATING TOW ARM

Spring loaded tow arm articulates for easy turning and comes with both a pin style and frame grab tools for easy integration with many common industrial carts.



Improve safety and productivity by reducing the strain involved in the transport of common industrial carts.

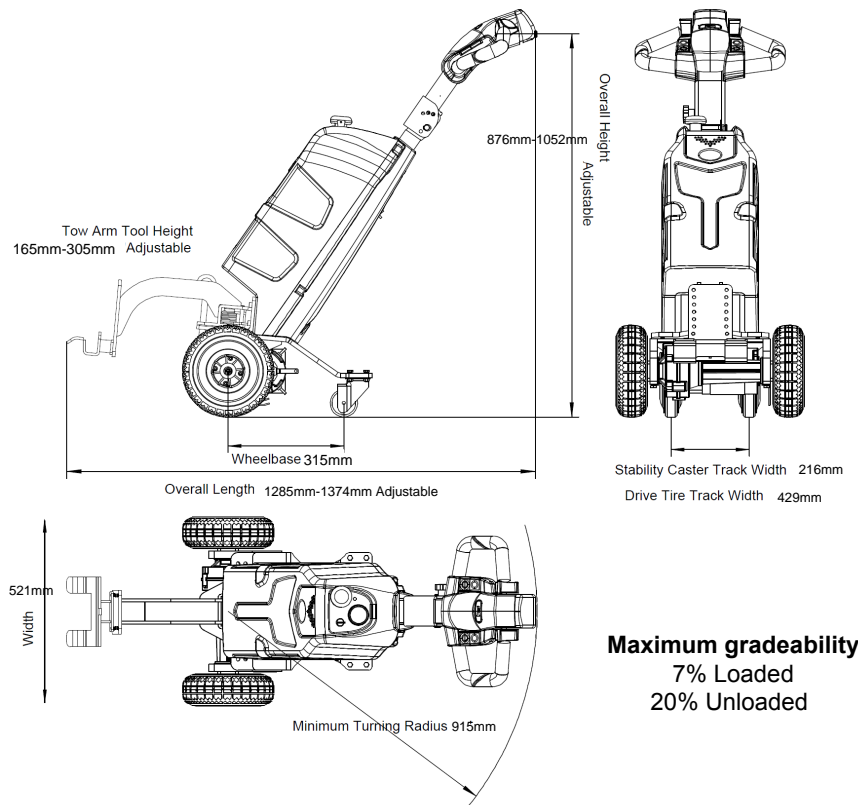

**Maximum gradeability**  
7% Loaded  
20% Unloaded

