



D40

Delivery Pallet Truck

ULTRA COMPACT DESIGN IS THE IDEAL SOLUTION FOR LIFT GATE AND LOCAL DELIVERY APPLICATIONS.

US Patents D739,112 : D770,719
D770,720: 9,586,605



CAPACITY

1800 kg

INTEGRAL BATTERY / CHARGER

(2) 12V 85AH maintenance free batteries
240V smart charger @15A (EZ40 @20A).

TRAVEL SPEED

24-Volt ZAPI Travel Controller

Variable from 0 to 5.6 km/h empty
Variable from 0 to 5.5 km/h loaded

WEIGHT

295kg with battery and charger

TIRES

DRIVE

230x75 polyurethane

STABILITY CASTERS

85x48 polyurethane

LOAD

74x88 / 80x60 polyurethane

TILLER ARM CONTROLS

Travel, lift, and lower functions are located in the ergonomic operator handle. All operator controls are accessible without having to lift the hand from the handle.

Angle grips are designed to allow easy operation with either hand. Wrap around guard, reversing switch, thumb control, and horn are standard. Low mounted tiller arm offers excellent operator comfort and minimum steering effort. Gas assisted spring tiller handle gently returns to vertical position when released.

Crawl speed function with steer handle at 5° back-tilt from vertical allows for ease of use in tight areas.

ELECTRICAL

Electric braking, quick disconnect EPD power cut off, key switch and battery discharge indicator are standard equipment.

HYDRAULICS

Lift cylinder has hard chrome plated rods. Pump unit including motor, solenoid, gear pump, and pressure compensated lowering valve are mounted high in the power compartment for ease of service.

DRIVE UNIT

Vertically mounted AC drive motor is direct mounted to gear housing. Oil bathed bevel gear drive train with tapered roller bearings transfers power to axle.

State of the art optimized gear technology supplies advantages such as zero maintenance, low noise level, high efficiency and high performance.

Electromagnetic brake is mounted on motor armature shaft multiplying the braking power through the transmission. Brake is applied when control arm is in the vertical or horizontal handle position. System features anti-roll back and neutral braking.

ACCESSIBILITY

Water resistant removal three piece power head cover exposes major components and maintenance free AGM batteries for inspection and maintenance.

OPTIONAL EQUIPMENT

- Rubber Lug Drive Tire
- Poly Traction Tire
- 1220mm Tall Load Back Rest
- 1520mm Tall Load Back Rest
- Fork Width - 560mm or 460mm
- Fork Length - 915mm
- Tool tray with Load Restraint
- Custom fork sizes available



BATTERY DISCHARGE INDICATOR, KEY SWITCH, EMERGENCY POWER DISCONNECT AND BUILT-IN AUTOMATIC BATTERY CHARGER

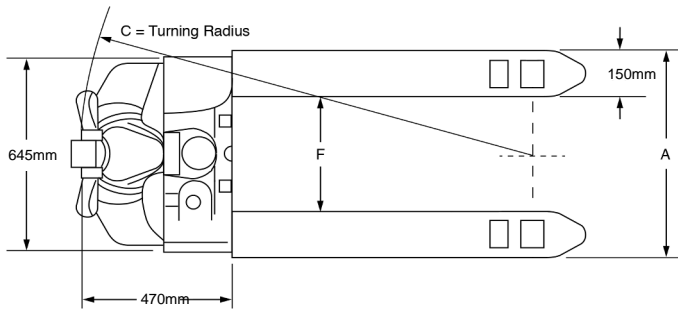
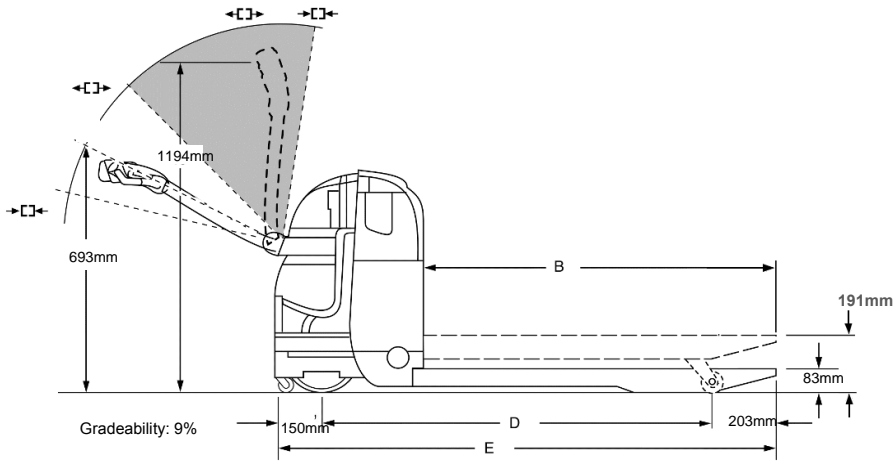

| Truck Model | Forks | Actual Fork Width | Actual Fork Length | Turning Radius | Wheelbase | Overall Length | Inside Fork Width | Weight (kg) |
|--|-----------|-------------------|--------------------|----------------|-----------|----------------|-------------------|-------------|
| | | A | B | C | D | E | F | |
| Fork Dimensions: 685mm, 560mm, and 460mm widths | | | | | | | | |
| D 40 | 685x 915 | 685 | 915 | 1245 | 1044 | 1397 | 386 | 288 |
| D 40 | 685x 1220 | 685 | 1150 | 1461 | 1273 | 1626 | 386 | 295 |
| D 40 | 685x 1320 | 685 | 1295 | 1613 | 1417 | 1778 | 386 | 308 |
| D 40 | 560x 915 | 541 | 915 | 1224 | 1044 | 1397 | 241 | 288 |
| D 40 | 560x 1220 | 541 | 1150 | 1461 | 1273 | 1626 | 241 | 295 |
| D 40 | 460x 915 | 460 | 915 | 1217 | 1044 | 1397 | 160 | 261 |
| D 40 | 460x 1220 | 419 | 1150 | 1438 | 1273 | 1626 | 160 | 295 |

^aEstimated shipping weight with (2) battery