



AIC1 Additional Injector Controller

Description:

The AIC1 Additional Injector Controller provides precise fuel delivery over the boosted operating range of an internal combustion engine. It is designed for use with engines that have been converted to forced induction with the addition of a turbo or supercharger. The AIC1 gives the user a convenient way to set the proper fuel mixture throughout the entire boost region.

The AIC1 can be ordered in a variety of configurations. Refer to the ordering information section to see the available combinations of pressures sensors, number of injectors and injector types. Both absolute and gauge pressure sensors are available. The absolute sensor can read both the vacuum and boost regions up to 16 psi. The gauge pressure sensor reads in the boost region only with an upper limit of 26 psi. The absolute pressure version is recommended for applications with under 16 psi of boost. There are also voltage input versions which may be used with external MAP or MAF sensors.

The AIC1 is intended for use with high impedance injectors only. Versions that drive two injectors use map A only. Versions with four injector drivers use map A to control two of the injectors, and map B to control the other two injectors.

The calibration of the AIC1 is done through a serial interface, which is active while in operation. The AIC1 is programmed with the R4 engine management software for Windows. The software provides real time display of RPM, manifold pressure, injector on time and duty cycle in percent. A variety of editing tools ease the task of setting up an initial map and quickly fine tuning for optimum performance.

With the 4-stroke setting selected, the AIC1 will fire the additional injectors on every other tach pulse. Use the 2-stroke setting to make it fire the injectors on every tach pulse. This will improve fuel distribution among cylinders. Set the number of cylinders to half the actual number to get the correct RPM reading when using the 2-stroke setting.

Features:

- Six different standard versions are available
- Internal absolute or gauge pressure MAP sensor versions
- Voltage input versions may be used with MAP or MAF sensor signals
- Two 2-dimensional map tables defined by boost pressure and RPM
- Compatible with 2 and 4 stroke engines from 1 to 12 cylinders
- Laptop programmable
- Programmed according to pulse width in milliseconds
- Transient surge and battery reversal protection

Typical Wire Assignments:

LABEL	CONNECT TO	MAP TABLE	WIRE COLOR
BATT+	Battery positive (+12V)		Red
BATT-	Battery negative (chassis ground)		Black
INJA+	Injector plug positive (+12V)	A	Red (2)
INJA-	Injector plug negative (injector driver)		Tan (2)
INJB+	Injector plug positive (+12V)	B	Red (2)
INJB-	Injector plug negative (injector driver)		Tan/Black (2)
TACH	Tach signal (pulses per rev = #cyl/2)		Yellow/Black
V IN	External MAP or MAF signal		Green*
F-DB9	Serial connector on computer		-

* On voltage versions only

Typical Connections:

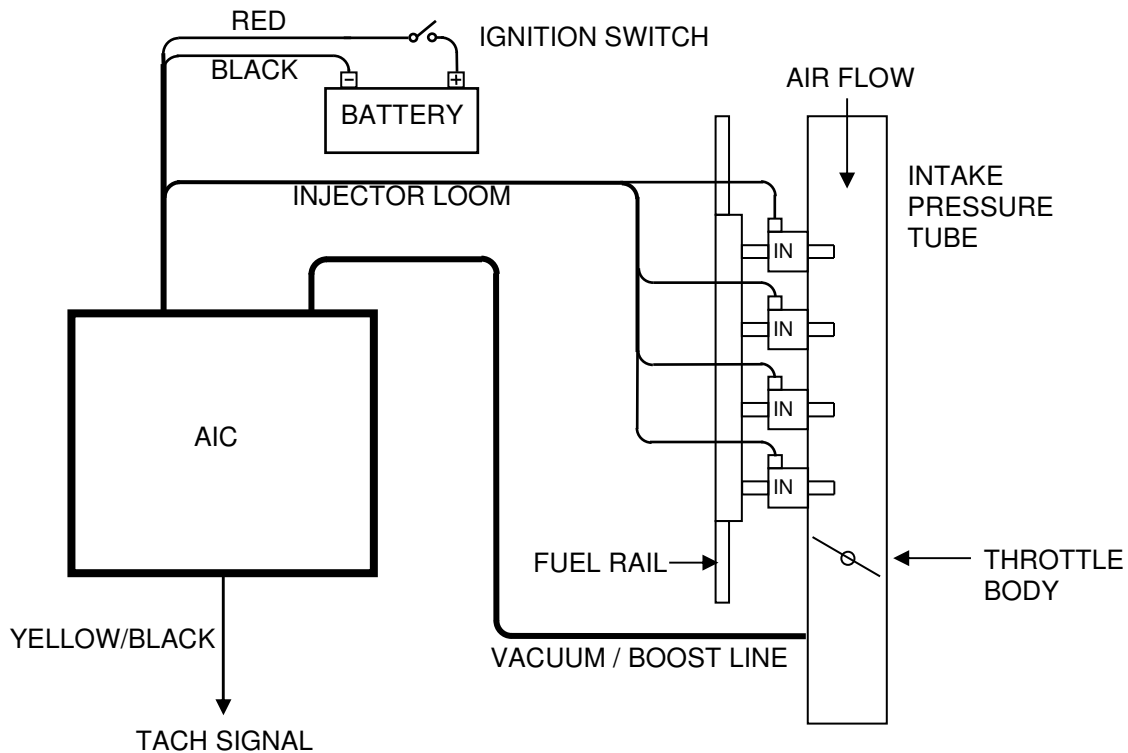

It is strongly recommended that a true-tach signal is used as the tach reference. A true-tach signal produces a number of pulses equal to the number of cylinders for each cam revolution. Use the 2-stroke setting to make the additional injectors fire on every tach pulse. This will improve fuel distribution among cylinders. Set the number of cylinders to half the actual number to get the correct RPM reading when using the 2-stroke setting.

Software:

The AIC1 is programmed with the R4 engine management software. When the software is launched an identification screen will appear that says Split Second. After four seconds, the main menu will appear. If this is a new application, select **File** then **New Customer** to create a new customer. Type in the customer name and save. The default location for customer names is My Documents.

When you return to the main screen, select **File** and **Open Customer** to open the customer file that you just created. Once the customer is open, the **Maps, View, Options** and **Help** tabs become active. You can fill in the various fields such as name, address etc. if you like.

Connections:

Connect the AIC1 to the computer using a USB to serial adapter cable. These cables require a software driver that must be properly installed on the computer. Select the proper com port for the serial adapter. The correct com port setting may be found under Ports in the Device Manager of the computer.

Remove the lid on the AIC1. Once the cable is plugged in and the AIC1 is powered up, you may connect to the AIC1 by selecting the **Connect to ECU** icon. Once communication has been established with the ECU, the **Real Time** pull down becomes active.

There are two map tables. Most versions use map A only. The versions that drive four injectors use both maps A and B. The connectors with tan wires are controlled by map A and those with tan/black wires are controlled by map B.

Programming:

Use **Options** and **System Settings** to select Additional Injector Controller and the correct pressure reading. If you have a gauge pressure sensor, select Gauge Pressure. If you have an absolute sensor, select Vacuum/Pressure. The Absolute Pressure setting may also be used if you prefer.

Use the **Options** pull down and **Engine Settings** to select the number of cylinders of the engine. The 2-stroke setting along with half the actual number of cylinders is recommended. That will result in the correct RPM reading with a true-tach RPM signal.

Use the **Maps** pull down to access the fuel map tables. The numbers entered into the cells on the map represent the injector on time in milliseconds. Whenever a cell is highlighted, the injector pulse width is shown in the upper left hand corner of the table.

You can click and drag to highlight an area of cells. Once highlighted, you can use the icons across the top of the window to fill all the selected cells with a value. For example, if you fill the selected cells with the value 10, whenever the manifold pressure and RPM match one of those cell locations, the injectors will be pulsed for 10 milliseconds.

A highlighted area of cells can also be changed by a percentage by using the **Change By** button. To increase a highlighted area of cells by 10 percent for example, select the cells, click on the **Change By** button and enter 10. To reduce by 50 percent, enter -50.

You can also fill a range of cells with values that are interpolated from the end points. This works over a row, column or 2-dimensional area. To fill values over a two dimensional area, fill the four corners of the area with cell values. Then click and drag to select the area encompassed by those corner cells. Click on the **Auto Fill** button. The software will calculate and fill the correct values for all highlighted cells.

If your AIC1 drives four injectors, you will have to fill in both map tables A and B. If you want to use the same values in both tables, you can copy and paste the data. Hit the **Select All** button while in the table you want to copy. Then press the **Copy** button. Go to the other map table and highlight the cell in the upper left hand corner of the table. Then press the **Paste** button.

Once the maps are set up, you can write to the ECU in the AIC1. To write to the ECU, the ignition must be on so that the AIC1 is powered up. The engine must be off so that tach pulses are not present during programming. To write to the ECU press the **Write Data to the ECU** button. You can also upload from the ECU using the **Read Data From the ECU** button. You can then save or modify the data.

During the tuning process, it is a good idea to periodically close the file you are working in and start a new file. This will make it possible to go back to a previous tune. Create and open a new customer file. Set the correct system settings, connect and Read Data from ECU. You are now ready to continue tuning. Use the notes field on the main screen to record pertinent information about the file.

Operation:

Once the data is loaded into the AIC1, the engine can be started. From the main screen, the **Real Time** pull down can be used to observe a variety of operating parameters. The **All** option brings up a window that displays boost pressure and RPM as well as pulse width and duty cycle for both A and B injectors. The All window can be enlarged to full screen size to make it easy to read while working on the engine. The **RPM** and **Pressure** options display analog gauges that show those parameters. The **All**, **RPM** and **Pressure** options can all be displayed simultaneously.

Ordering Options:

Part Number	Number of Injectors	Injector Impedance	MAP Sensor Type	Map Tables Used
AIC1-A2H	2	High	Absolute	A
AIC1-A4H	4	High	Absolute	A and B
AIC1-G2H	2	High	Gauge	A
AIC1-G4H	4	High	Gauge	A and B
AIC1-V2H	2	High	none	A
AIC1-V4H	4	High	none	A and B

Electrical Characteristics:

PARAMETER	CONDITIONS	MIN	TYP	MAX	UNITS
Supply Voltage	BATT+ to BATT-	12	13.5	15	V
Supply Current	Into BATT+ terminal		16		mA
Tach threshold	Normal operation		2.5		V
Tach Hysteresis	Normal operation		0.5		V
Boost Range	On vacuum/boost hose	0		26	PSI
H Injector limit	Max current before shutdown		2		A

Mechanical Characteristics:

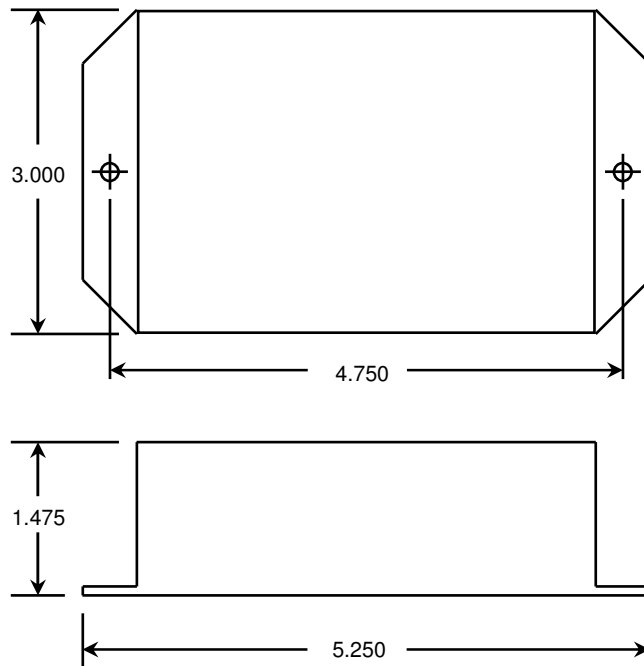

1949 E. Deere Ave.
 Santa Ana, CA 92705
 TEL (949) 863-1359
 FAX (949) 863-1363