

C022-417-282
AVONDALE

ASSEMBLY INSTRUCTIONS

TWO (2) PEOPLE AND PHILIP WRENCH REQUIRED

PLEASE UNPACK ALL PARTS AND CHECK AGAINST PARTS LIST ON THIS INSTRUCTION SHEET BEFORE DISCARDING PACKING AND CARTON!!



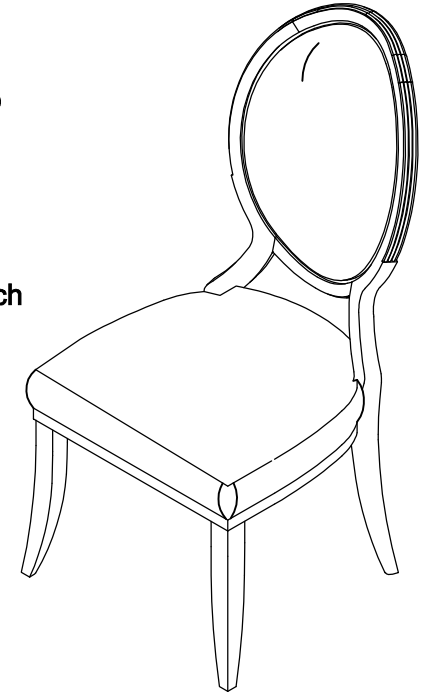



- 1) Assemble the Back Assembly (1) and the Seat Assembly (2) using Flat Washer (C) , Lock Washer (D) and Bolt (F) to fit into the center hole on the back of the Seat Assembly (2), tighten by Wrench provided (E) as shown in (Drawing A)
- 2) Assemble the Back Leg of the Back Assembly (1) and the Seat Assembly (2) securely using Flat Washers (C) , Lock Washers (D), Bolts(A) and Wrench provided (E) as shown in (Drawing A).
- 3) Assemble the Front Legs and the Seat Assembly (2) using Flat Washers (C) , Lock Washers (D), Bolt (B) and Wrench provided (E) as shown in (Drawing B).
- 4) Turn the chair to upright position then tighten all of the bolts by Wrench provided (E).



***** NOTE KEEP THIS SHEET!!! *****

In the unlikely event that you would need a replacement part for your table, please contact your local authorized Schnadig International dealer. If you need replacement hardware quickly, it could be purchased from your local hardware store.

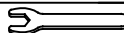
CLA-417-282		
VERY APPEALING		
Part Description	Part No.	QTY
Chair Back (1)	C022-417-282-4062	1
Seat Assembly (2)	C022-417-282-4061	1
Front Leg (3)	C022-417-282-4019	2
RTA Hardware	C022-417-282-4001	1
Nail-in Floor Glide	C022-417-282-4086	4

NO	Hardware List			Q'ty
A		Bolt	5/16"x3-1/4"	4
B		Bolt	5/16"x1-15/16"	4
C		Flat Washer	5/16"	9
D		Lock Washer	5/16"	9
E		Wrench	5/16"	1
F		Bolt	5/16"x2-1/2"	1

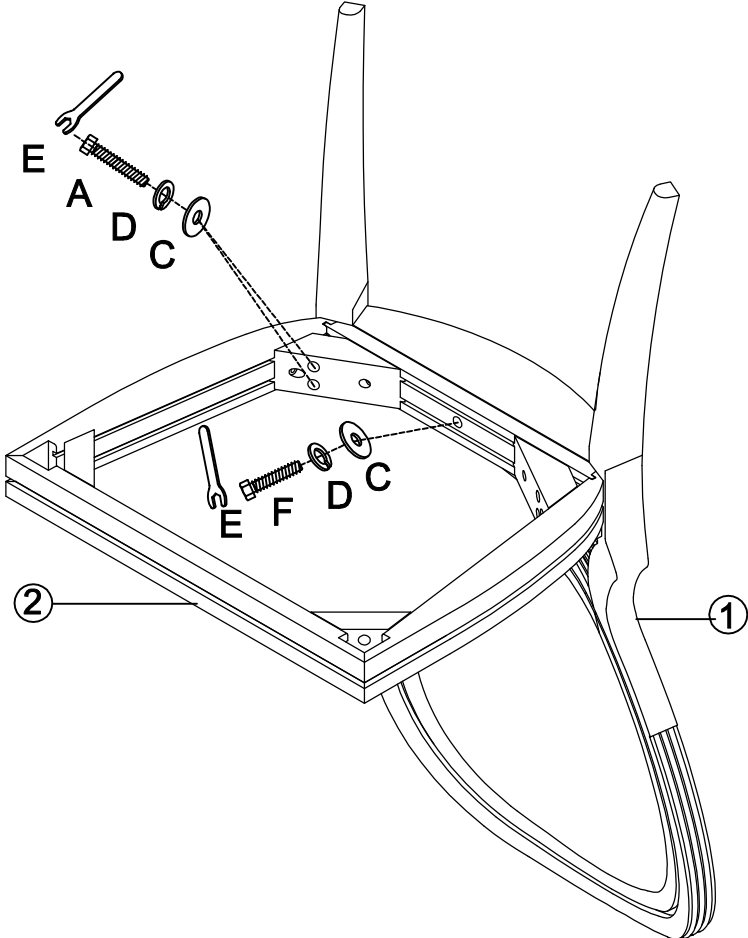

Drawing A

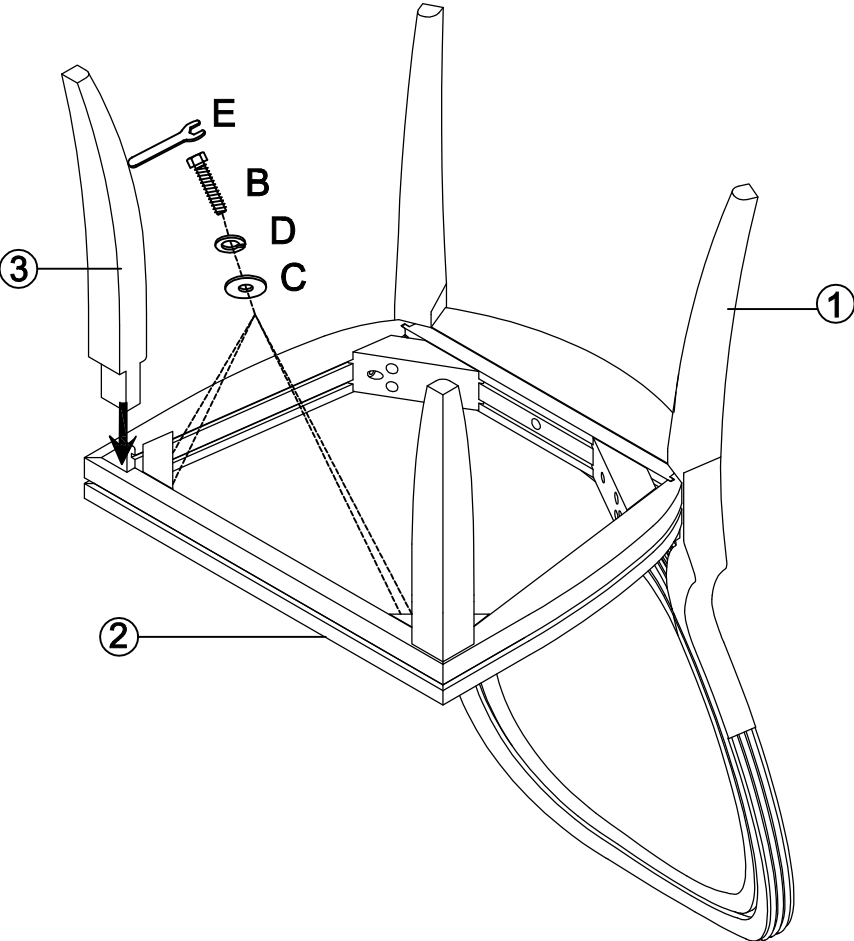

Drawing B