

# CLA-5423-104-124 QUEEN / KING BED

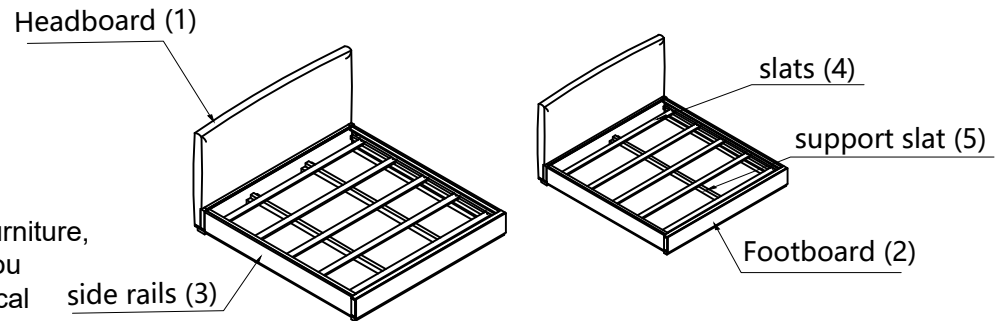
## CARACOLE CLASSIC

### ASSEMBLY INSTRUCTIONS

TWO (2) PEOPLE AND SCREWDRIVER REQUIRED

PLEASE UNPACK ALL PARTS AND CHECK AGAINST PARTS LIST ON THIS INSTRUCTION SHEET BEFORE DISCARDING PACKING AND CARTON!!

- 1) Connect the side rail and headboard/footboard by bolt (F).
- 2) Assemble the side rail and headboard/footboard using the curved washer (A), flat washer (C), lock washer (B), and nut (D) tighten with wrench provided (E), as shown in Diagram A.
- 3) Assemble the center support rail as shown in Diagram B.
- 4) Attach the bed slats on center support rail and cleat of side rails then using Philips screw driver to tighten the screw (G) as shown in Diagram C.



\*\*\* NOTE KEEP THIS SHEET!!! \*\*\*

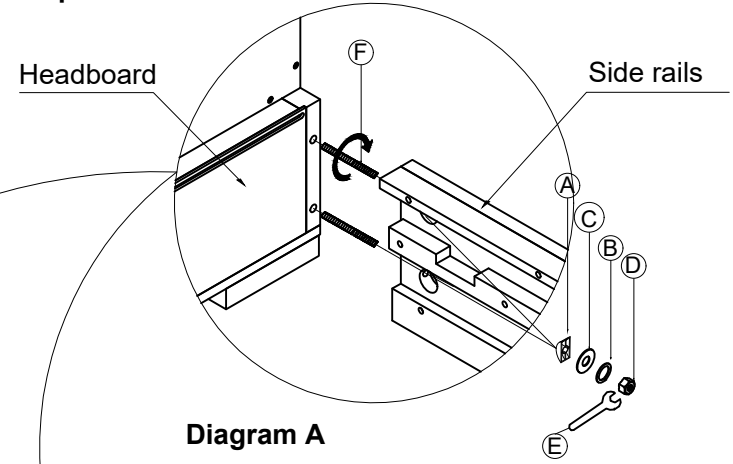
In the unlikely event that you would need a replacement part for your furniture, please contact your local authorized Caracole International dealer. If you need replacement hardware quickly, it could be purchased from your local hardware store.

Part Description	CLA-5423-104 QN BED		CLA-5423-124 KG BED	
	Part No.	QTY	Part No.	QTY
1 Headboard	CLA-5423-104-H	1 (pc)	CLA-5423-124-H	1 (pc)
2 Footboard	CLA-5423-104-F	1 (pc)	CLA-5423-124-F	1 (pc)
3 Side rail	CLA-5423-104-R	2 (pcs)	CLA-5423-124-R	2 (pcs)
4 Slats	CLA-5423-104-3067	5 (pcs)	CLA-5423-124-3067	5 (pcs)
5 Center Support Rail	CLA-5423-104-30447	1 (pc)	CLA-5423-104-30447	2 (pcs)
6 Assembly Hardware (1)	CLA-5423-104-3001	1 (pc)	CLA-5423-104-3001	1 (pc)

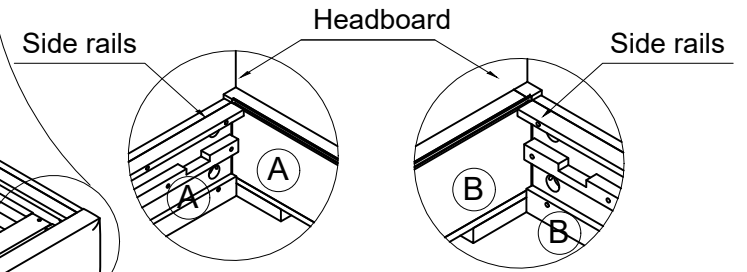
RTA Hardware (1) For Side rail and slats of KB and QB		
NO.	Hardware List	Qty
A	Curved Washer(5/16") Ø28x15x76mm	8 (pcs)
B	Lock Washer (5/16"x13mm)	8 (pcs)
C	Flat Washer (5/16"x16x2mm)	8 (pcs)
D	Nut (5/16"x12mm)	8 (pcs)
E	Wrench (5/16") 88x12mm	1 (pc)
F	Bolt (5/16"x90mm)	8 (pcs)
G	Screws(#8x1-1/8")	10 (pc)

Created on: 2023-06-26

**Step 1.**

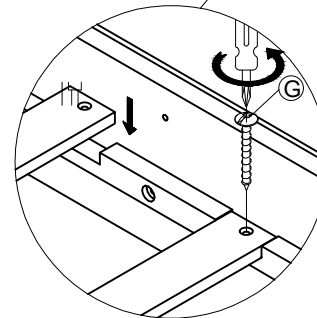


**Diagram A**



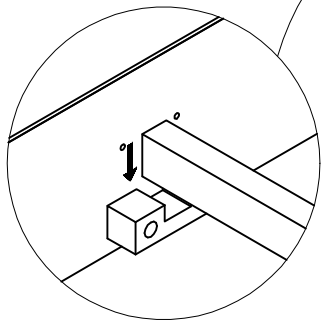
On inside face of Headboard and Side rails notice A and B , need assembly correct position A-A , B-B as shown

**Step 3.**

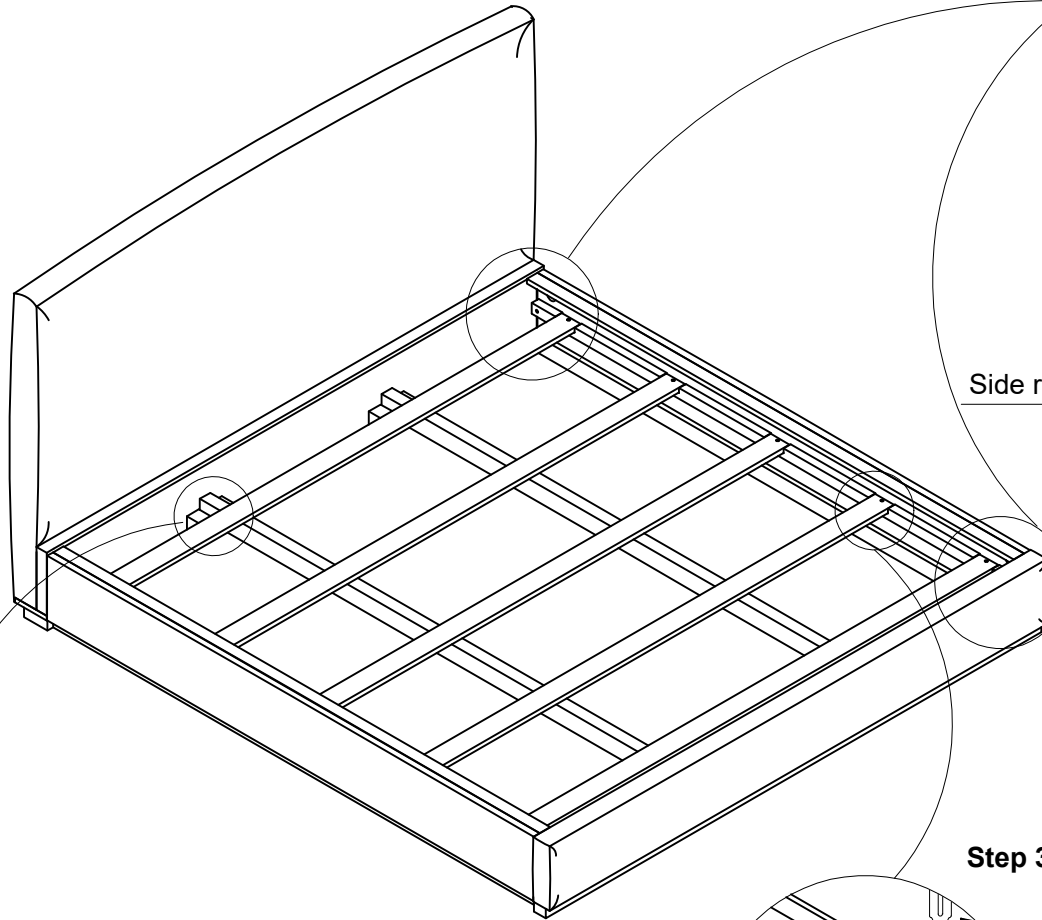


**Diagram C**

**Step 2.**



**Diagram B**



# BED MATTRESS DIAGRAM

## BEDDING SPECIFICATIONS

**CLA-5423-104** Dimension of the mattress opening: 82" x 62"

Bed slats:  $65\frac{1}{4}" \times 3\frac{1}{4}" \times \frac{3}{4}"$

**CLA-5423-124** Dimension of the mattress opening: 82" x 78"

Bed slats:  $81\frac{1}{2}" \times 3\frac{1}{4}" \times \frac{3}{4}"$

Side rail width:  $2\frac{3}{4}"$

Height from the floor to bottom of the side rail: 0

Height from the floor to top of slat:  $7\frac{1}{4}"$ .

Height from the top of slats to top of side rail:  $4\frac{1}{4}"$ .

Height from the top of side rail to bottom of headboard pad: 0

Be sure to adhere to these BEDDING SPECIFICATIONS in order to avoid the possibility of falling or entrapment THESE SPECIFICATIONS MUST BE STRICTLY ADHERE TO!

