

# CLA-420-261 TIME TO REFLECT

## CARACOLE CLASSIC

### ASSEMBLY INSTRUCTIONS

#### TWO(2)PEOPLE REQUIRED



PLEASE UNPACK ALL PARTS AND CHECK AGAINST PARTS LIST ON THIS INSTRUCTION SHEET BEFORE DISCARDING PACKING AND CARTON!!





1. Lay on it's back on a soft, clean surface.
2. Attach legs to bottom frame using the flat washer (C), lock washer (D) and bolt (E), tighten with wrench provided (F). as shown in Diagram A
3. Bottom glass shelf is packaged at the bottom of the case interior, please unpack it then put on the correct location, assembly the shelf pin first then put the glass shelf on the shelf pin. The other 3 shelves packaged on top of the case, please unpack it then put on the correct location.

\*\*\* NOTE KEEP THIS SHEET!!! \*\*\*

In the unlikely event that you would need a replacement part for your furniture, please contact your local authorized Caracole International dealer. If you need replacement hardware quickly, it could be purchased from your local hardware store.

CLA-420-261 TIME TO REFLECT		
Part Description	Part No.	QTY
Anti-tip Restraint	CLA-420-011-30157	1
Drawer Pull with bolt and plastic washer	CLA-420-261-4084	1set
Adjustable Floor Glide	CLA-420-011-3086	4
Single Can Light	CLA-420-261-40358	1
Glass Shelf	CLA-420-261-4028	3
Glass Top Insert	CLA-420-261-4029	1
Leg	CLA-420-261-4018	4
RTA Hardware	CLA-420-261-4001	1
Hinge	CLA-420-261-4005	1
Glass Pad	CLA-420-261-4010	6

RTA Hardware Hardware List			
			Q'ty
A		Shelf Support with Hole	12
B		Clear Bumper	12
C		Flat Washer: 5/16	8
D		Lock Washer: 5/16	8
E		Bolt 5/16(in)x2.5(in)	8
F		Wrench	1

G		Glass Pad	6
H		Drawer Pull	1
I		Plastic Washer	4
J		Bolt 5/32(in)x0.47(in)	2

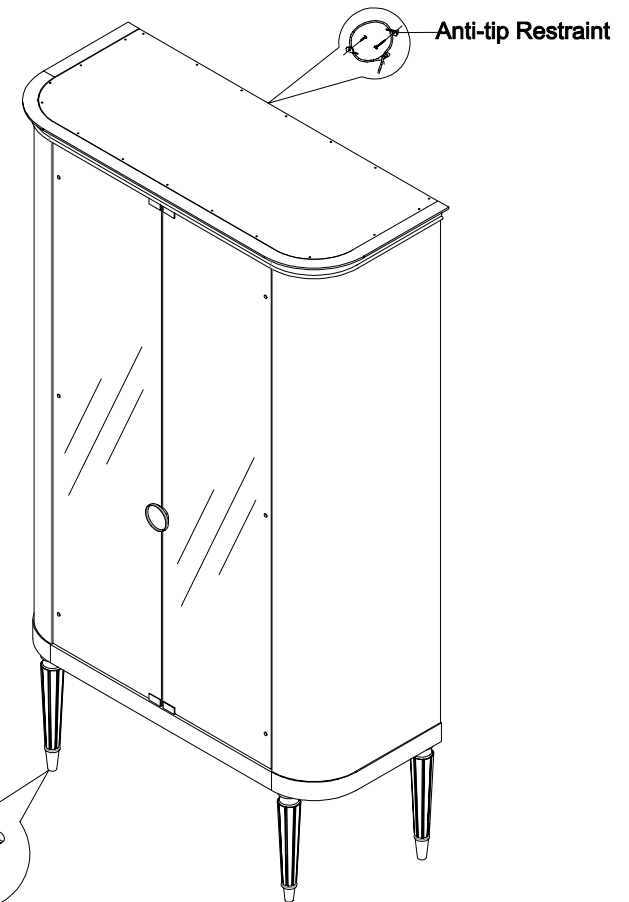

Adjustable Floor Glide

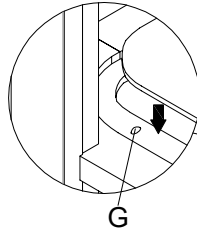
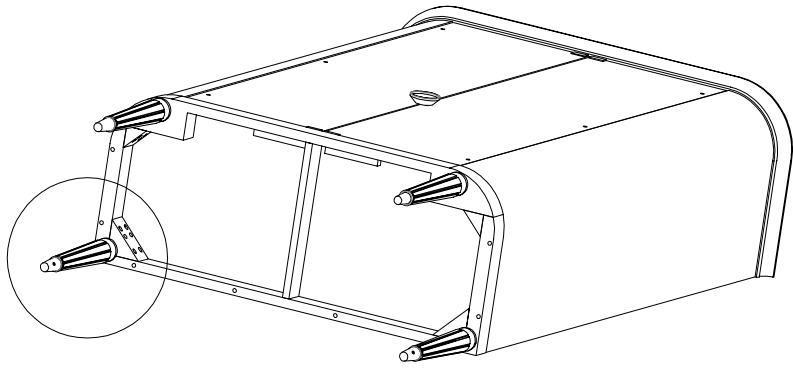

Glass Shelf

Glass Top Insert

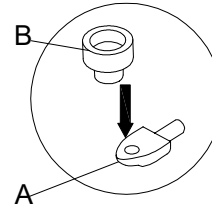
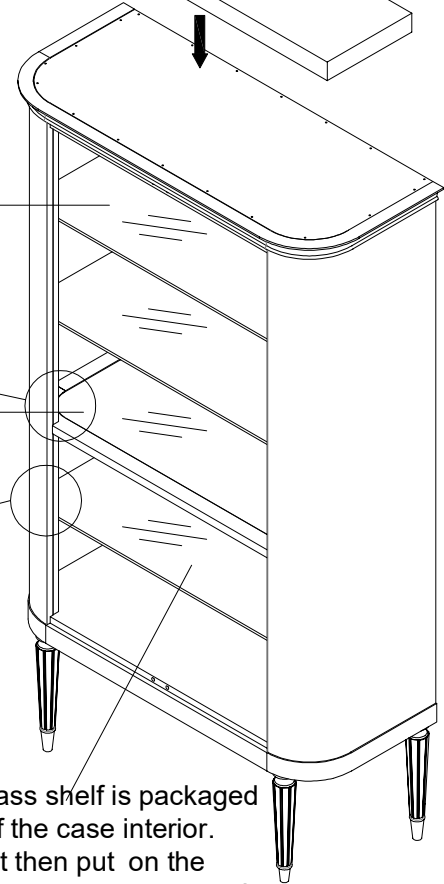

Diagram B

The other 3 shelves packaged on top of the case

glass shelf enclosed

2 of 2



Note: Bottom glass shelf is packaged on the bottom of the case interior. Please unpack it then put on the correct location . Assembly the shelf pin first then put the glass shelf on the shelf pin.

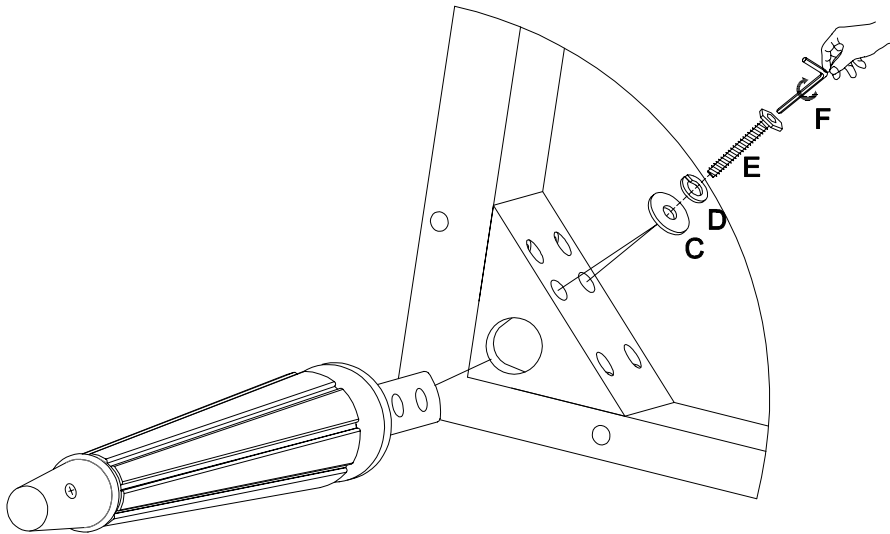

Diagram A