

CLA-021-102-122H/F/R BEAUTY SLEEP QUEEN/KING BED CARACOLE CLASSIC

ASSEMBLY INSTRUCTIONS

TWO(2)PEOPLE AND PHILIP'S SCREWDRIVER REQUIRED

UNPACK ALL PARTS AND CHECK AGAINST PARTS LIST ON THIS INSTRUCTION SHEET BEFORE DISCARDING PACKING AND CARTON!!

- 1) Connect the side rails and headboard / footboard by bolt (F).
- 2) Assemble the side rails and headboard / footboard using the curved washer (A), flat washer (B), lock washer (C), and nut (D) tighten with wrench provided (E), as shown in Diagram A.
- 3) Attach the support legs to slats using flat washer (K), lock washer (L) and bolt (J), tighten by wrench provided (M). Adjust the support leg if necessary as shown in Diagram B.
- 4) Attach the adjustable slats system (H) to the side rails and locked to a needed position,using Philips screw drive to tighten the screw (G) if necessary. Attach the assembled slats & support leg to the adjustable slats system using bolt (N) , tighten by wrench provided (R) . Using Philips screw drive to tighten the screw (G) if necessary as shown in Diagram C.

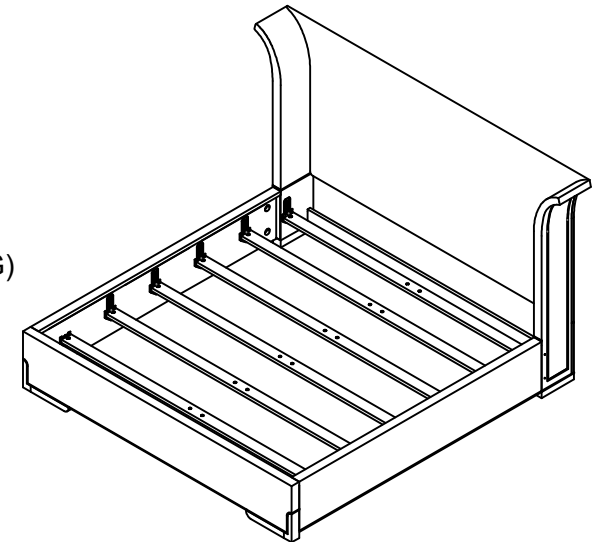

*** NOTE KEEP THIS SHEET!!! ***

In the unlikely event that you would need a replacement part for your furniture, please contact your local authorized Caracole International dealer. If you need replacement hardware quickly, it could be purchased from your local hardware store.

Part Description	CLA-021-102H/F/R		CLA-021-122H/F/R	
	QUEEN BED		KING BED	
Part Description	Part No.	QTY	Part No.	QTY
Headboard (1)	CLA-021-102-H	1	CLA-021-122-H	1
Footboard (2)	CLA-021-102-F	1	CLA-021-122-F	1
Side rail (3)	CLA-021-102-R	2	CLA-021-102-R	2
Slat (4)	CLA-021-102-F-3067	5	CLA-021-122-F-3067	5
Support leg(5)	CLA-021-102-F-30305	6	CLA-021-122-F-30305	6
RTA Hardware(6)	CLA-021-102-H-3001	1	CLA-021-122-H-3001	1
RTA Hardware(7)	CLA-021-102-F-3001	1	CLA-021-122-F-3001	1
RTA Hardware(8)	CLA-021-102-R-3001	1	CLA-021-102-R-3001	1
Slat of Headboard(10)	CLA-021-102-H-3067	1	CLA-021-122-H-3067	1

RTA Hardware (8) for side rails			
NO.	Hardware List	Q'ty	
A	Curved Washer	8	
B	Flat Washer	8	
C	Lock Washer	8	
D	Nut	8	
E	Wrench(5/16)	1	
F	Bolt	8	
G	Screw(3.5x18)	20	
H	Adjustable slats system	10	

RTA Hardware (7) For Support leg and slat			
NO.	Hardware List	Q'ty	
J	Bolt	10	
K	Flat Washer	10	
L	Lock Washer	10	
M	Wrench	1	
N	Bolt	10	
R	Wrench	1	
G	Screw(4.2x20)	20	

RTA Hardware (6) For Support leg and slat			
NO.	Hardware List	Q'ty	
J	Bolt	2	
K	Flat Washer	2	
L	Lock Washer	2	
M	Wrench	1	

