

# CLA-020-203T&CLA-020-203B ALL NATURAL CARACOLE CLASSIC

**ASSEMBLY INSTRUCTIONS**

**TWO (2) PEOPLE AND PHILIP WRENCH REQUIRED**

**PLEASE UNPACK ALL PARTS AND CHECK AGAINST PARTS LIST ON THIS INSTRUCTION SHEET BEFORE DISCARDING PACKING AND CARTON!!**

Turn the table top face down on a smooth, clean surface, attached the table base to table top using flat washer (C), lock washer (B) and bolt (A) , tighten with wrench provided (D) as shown in Drawing 1.

**\*\*\* NOTE KEEP THIS SHEET!!! \*\*\***

In the unlikely event that you would need a replacement part for your furniture, please contact your local authorized Caracole International dealer. If you need replacement hardware quickly, it could be purchased from your local hardware store.

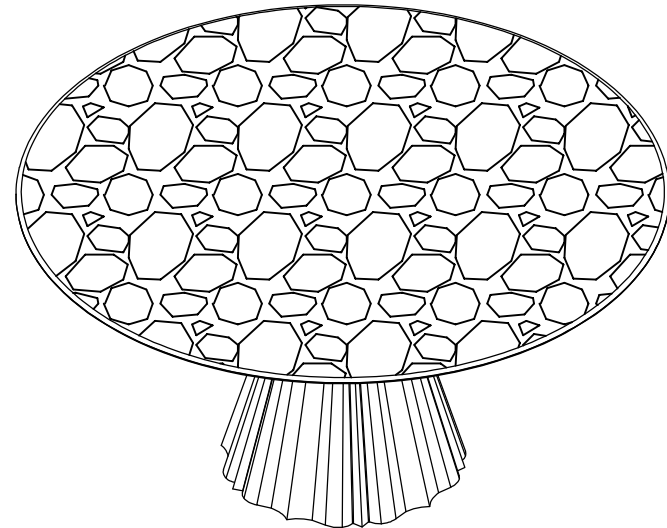

CLA-020-203T&CLA-020-203B		
CULT CLASSIC		
Part Description	Part No.	QTY
Top / Apron Assembly (1)	CLA-020-203T-40123	1
Table Bases (2)	CLA-020-203B-40153	1
RTA Hardware	CLA-020-203T-4001	2
Felt Pad	CLA-020-203B-40318	6

NO.	Hardware List			Q'ty
A		Bolt	5/16"X1 1/4"	4
B		Lock Washer	5/16"	4
C		Flat Washer	5/16"	4
D		Wrench	5/16"	1

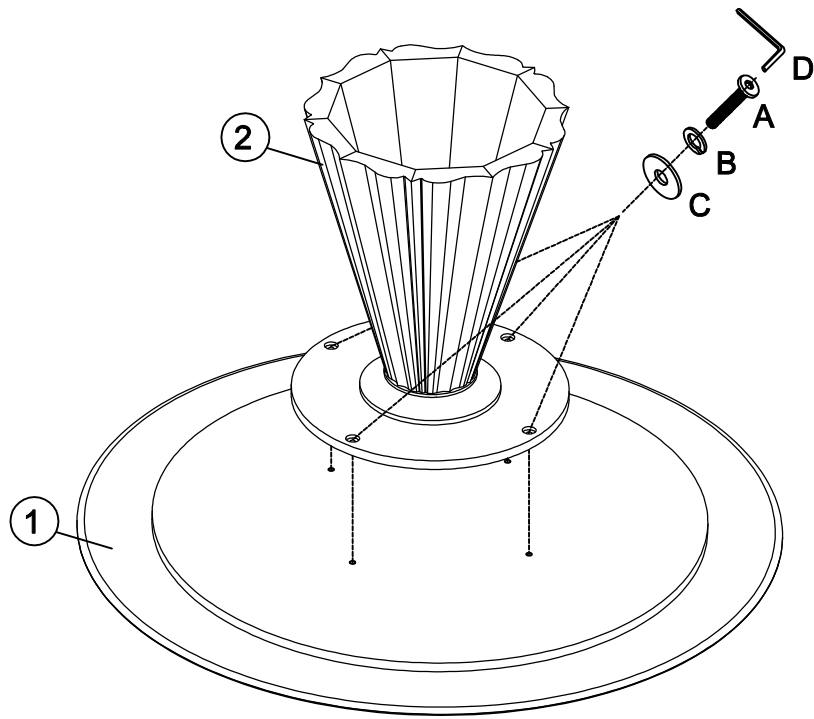

Drawing 1

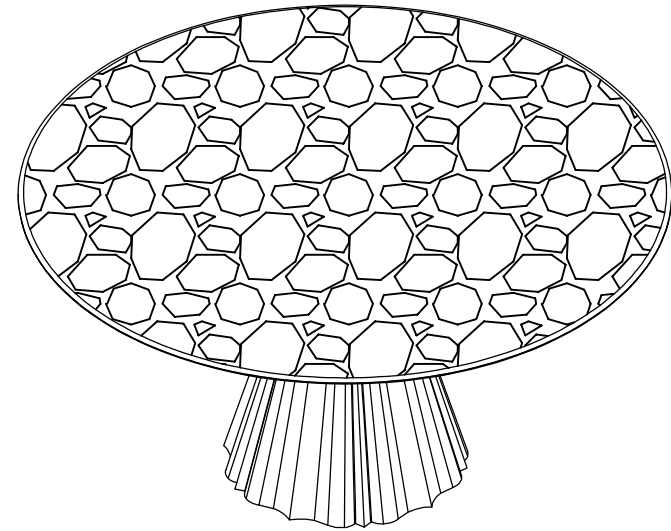

Drawing 2