

CLA-017-105/125H/F/R-145R A NIGHT IN PARIS QUEEN/KING/ CK BED

CARACOLE CLASSIC

ASSEMBLY INSTRUCTIONS

TWO (2) PEOPLE AND PHILIP'S SCREWDRIVER REQUIRED

PLEASE UNPACK ALL PARTS AND CHECK AGAINST PARTS LIST ON THIS INSTRUCTION SHEET BEFORE DISCARDING PACKING AND CARTON!!

- 1) Connect the side rails and headboard / footboard by bolt (F).
- 2) Assemble the side rails and headboard / footboard using the curved washer (A), flat washer (B), lock washer (C), and nut (D) tighten with wrench provided (E), as shown in Diagram A.
- 3) Attach the support legs to slats using flat washer (K), lock washer (L) and bolt (J), tighten by wrench provided (M). Adjust the support leg if necessary as shown in Diagram B.
- 4) Attach the adjustable slats system (H) to the side rails and locked to a needed position, using Philips screw drive to tighten the screw (G) if necessary. Attach the assembled slats & support leg to the adjustable slats system using flat washer (P), lock washer (Q), bolt (N) and nut (O), tighten by wrench provided (R) and (S). Using Philips screw drive to tighten the screw (G) if necessary as shown in Diagram C.

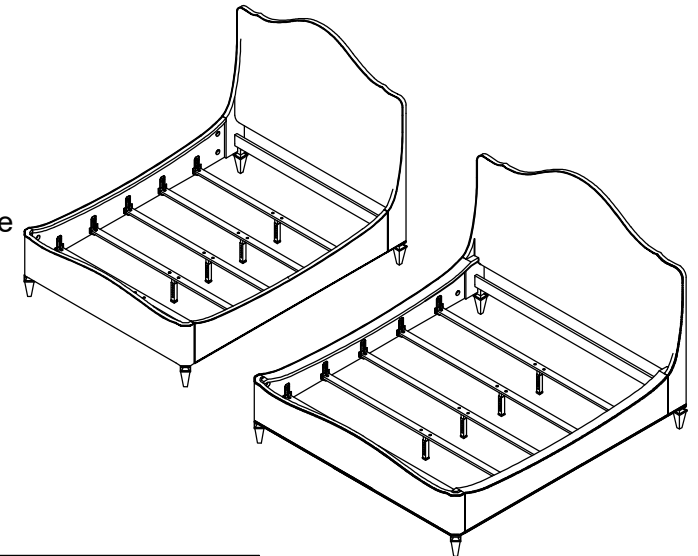

*** NOTE KEEP THIS SHEET!!! ***

In the unlikely event that you would need a replacement part for your table, please contact your local authorized Schnadig International dealer. If you need replacement hardware quickly, it could be purchased from your local hardware store.

Part Description	CLA-017-105H/F/R		CLA-017-125H/F-105R		CLA-017-125H/F-145R	
	QN BED		KG BED		CK BED	
Part No.	QTY	Part No.	QTY	Part No.	QTY	
Headboard (1)	CLA-017-105H	1	CLA-017-125-H	1	CLA-017-125-H	1
Footboard (2)	CLA-017-105F	1	CLA-017-125-F	1	CLA-017-125-F	1
Side rail (3)	CLA-017-105R	2	CLA-017-105-R	2	CLA-017-145-R	2
Slat (4)	CLA-017-105-F-3067	5	CLA-017-125-F-3067	5	CLA-017-125-F-3067	5
Support leg(5)	CLA-017-105-F-30305	5	CLA-017-125-F-30305	5	CLA-017-125-F-30305	5
RTA Hardware(6)	CLA-017-105-F-3001	2	CLA-017-125-F-3001	2	CLA-017-125-F-3001	2
RTA Hardware(7)	CLA-017-105-R-3001	1	CLA-017-125-R-3001	1	CLA-017-145-R-3001	1

RTA Hardware (3)		
NO.	Hardware List	Q'ty
A	Curved Washer	8
B	Flat Washer	8
C	Lock Washer	8
D	Nut	8
E	Wrench	1
F	Bolt	8
G	Screw(4.2x20)	20
H	Adjustable slats system	10

RTA Hardware (2)		
NO.	Hardware List	Q'ty
J	Bolt	10
K	Flat Washer	10
L	Lock Washer	10
M	Wrench	1

RTA Hardware (4)		
NO.	Hardware List	Q'ty
N	Bolt	10
O	Nut	10
P	Flat Washer	10
Q	Lock Washer	10
R	Wrench	1
S	Wrench	1
G	Screw(4.2x20)	20

