

ADELA

ASSEMBLY INSTRUCTIONS
TWO (2) PEOPLE REQUIRED

PLEASE UNPACK ALL PARTS AND CHECK AGAINST PARTS LIST ON THIS INSTRUCTION SHEET BEFORE DISCARDING PACKING AND CARTON!!

- 1) Turn the Top face down on a smooth, soft surface.
- 2) Attach table legs to each corner using lock washer (B) flat washer (C) and bolt (A). Tighten with wrench provided (D), as shown in Drawing 2 .
- 3) Carefully turn the table to the upright position which requires at least 2 person. Then place the center Leaves (2) as shown in Drawing 3 .
- 4) Use bottom locks to pull the leaves tightly together.

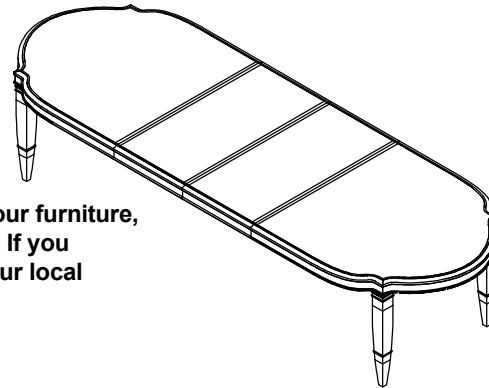

*** NOTE KEEP THIS SHEET ***

In the unlikely event that you would need a replacement part for your furniture, please contact your local authorized Schnadig International dealer. If you need replacement hardware quickly, it could be purchased from your local hardware store.

C012-016-201		
RECTANGULAR DINING TABLE		
Part Description	Part No.	QTY
Leg	C012-016-201-4018	4
Dining Table Leaf	C012-016-201-4060	2
Dining Table Lock	C012-016-201-40150	6sets
Nail-in Floor Glide	C012-016-201-4086	4
RTA Hardware	C012-016-201-4001	1

NO.	Hardware List			Q'ty
A		Bolt	5/16"	8
B		Lock Washer	5/16"	8
C		Flat Washer	5/16"	8
D		Wrench	5/16"	1

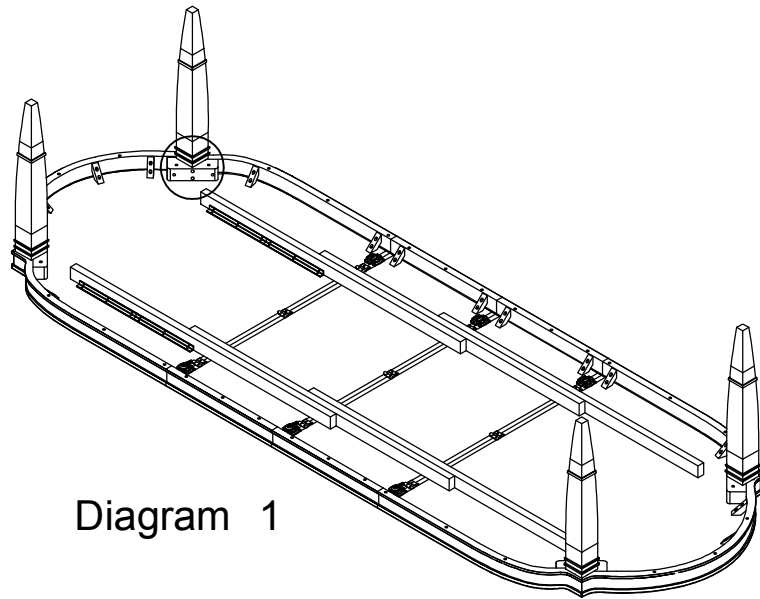

Diagram 1

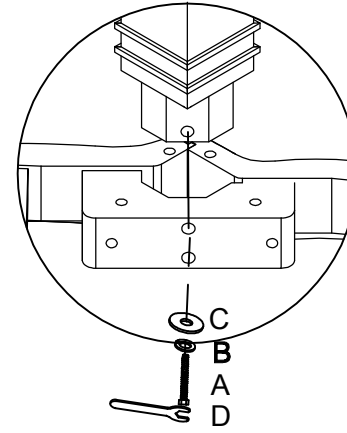

Diagram 2

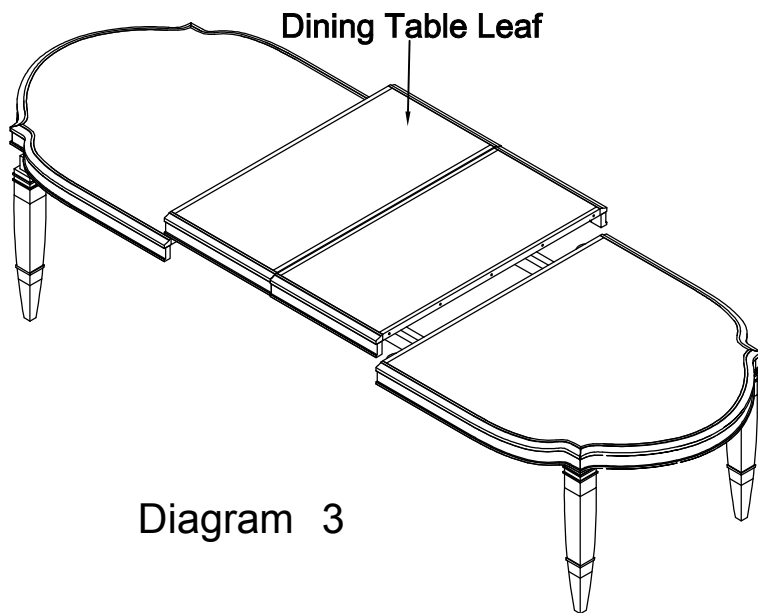

Diagram 3

