

# RENNWAGEN

## INSTALL GUIDE

VW-MK7-GTI-RSPAT-V3

---

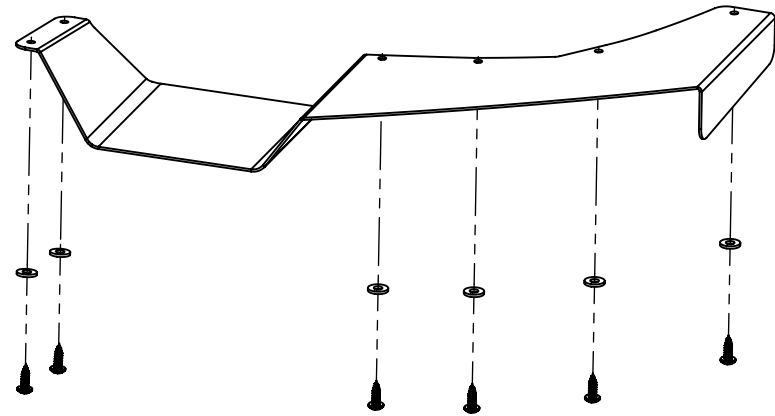
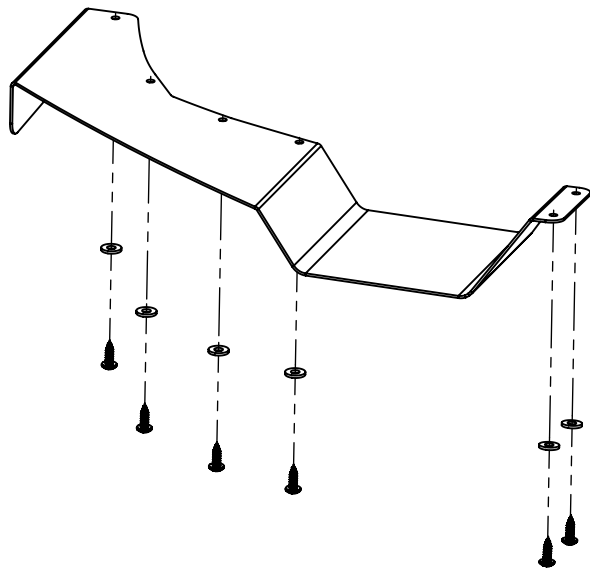

# RENNWAGEN

## INCLUDED IN YOUR KIT:

QTY	DESCRIPTION
1	REAR SPAT (DRIVER)
1	REAR SPAT (PASSENGER)
12	STAINLESS STEEL PHILLIPS HEAD SCREWS
12	STAINLESS STEEL WASHERS

## TOOLS:

	PHILIPS HEAD SCREW DRIVER
	DRILL
	DRILL BIT (1/8")
	MARKER OR PEN



## **BEFORE YOU BEGIN:**

- READ THROUGH THE INSTALLATION GUIDE ENTIRELY PRIOR TO INSTALLING THIS PRODUCT.
- CHECK TO MAKE SURE NOTHING IS MISSING FROM YOUR ORDER.
- DO NOT USE POWER TOOLS ON HARDWARE!
- DO NOT OVERTIGHTEN HARDWARE!

**NOTE: PROFESSIONAL INSTALLATION IS RECOMMENDED. RENNWAGEN, LLC IS NOT RESPONSIBLE FOR DAMAGE TO YOU OR YOUR VEHICLE WHILE INSTALLING RENNWAGEN PRODUCTS.**

## STEP 1 - CLEAN

CLEAN THE OEM REAR VALANCE ON YOUR CAR AND ENSURE IT IS FREE OF ANY DIRT OR ROAD GRIME.

## STEP 2 - TEST FIT

LINE UP AND TEST FIT THE REAR SPATS WITH THE OEM VALANCE. THERE IS A SMALL PLASTIC LIP ON THE OEM VALANCE THAT THE REAR SPAT WILL LOCATE AGAINST.

## STEP 3 - MARK HOLE LOCATIONS

STARTING ON ONE SIDE OF THE CAR, HOLD THE REAR SPAT IN PLACE AND USE A MARKER OR PEN TO MARK THE OUTER HOLE CENTERS ON THE OEM VALANCE. REPEAT THIS STEP FOR THE OPPOSITE SIDE.



*YOU CAN USE A STRIP OF MASKING TAPE TO AVOID MARKING ON YOUR OEM VALANCE IF YOU WISH.*

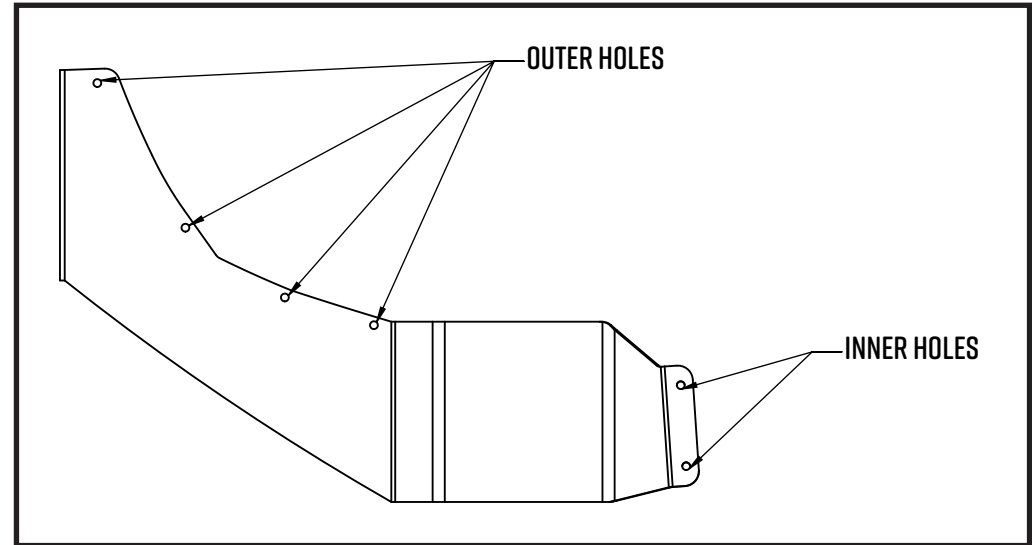

STEP 3 - HOLE DIAGRAM



STEP 3 - NOTE FITMENT

## STEP 4 - DRILL MOUNTING HOLES

REMOVE THE REAR SPATS AND SET THEM ASIDE. USING A DRILL AND AN 1/8" DRILL BIT, DRILL A PILOT HOLE AT THE CENTER OF EACH OF YOUR MARKED HOLES. (IT IS CRITICAL THAT THE HOLE IS CENTERED).

 *IF YOUR CAR IS LOWERED, YOU MAY NEED TO LIFT YOUR CAR UP IN ORDER TO FIT YOUR DRILL UNDERNEATH THE OEM VALANCE.*

## STEP 5 - INSTALL HARDWARE

STARTING ON ONE SIDE OF THE CAR, HOLD THE REAR SPAT IN PLACE AND VERIFY THAT THE HOLES YOU JUST DRILLED LINE UP WITH THE HOLES IN THE REAR SPAT. THEN, USING A PHILLIPS HEAD SCREWDRIVER, THREAD THE SUPPLIED STAINLESS STEEL SCREWS INTO THE HOLES THAT YOU DRILLED IN THE PREVIOUS STEP. MAKE SURE YOU USE A WASHER BETWEEN THE REAR SPAT AND EACH SCREW.



STEP 5 - HARDWARE INSTALLED

## STEP 6 - MARK HOLE LOCATIONS

WITH HARDWARE INSTALLED IN THE OUTER HOLES ON THE REAR SPATS, LINE UP THE INNER HOLES WITH THE OEM VALANCE AND MARK THE HOLE CENTERS FOR THE REMAINING (X2) INNER HOLES ON EACH SIDE.



*YOU MAY NEED TO SLIGHTLY FLEX THE REAR SPAT IN ORDER TO GET IT TO LINE UP PROPERLY.*

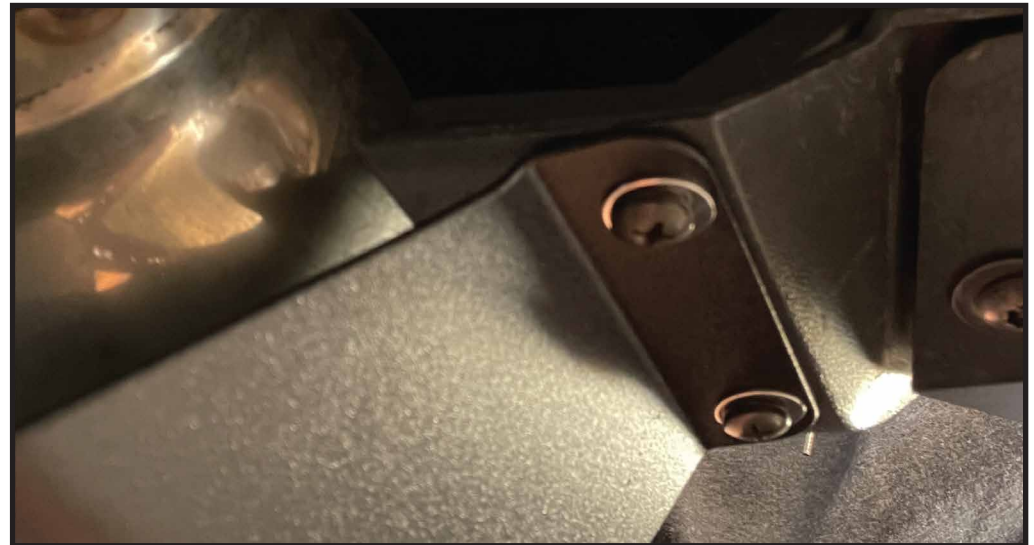

STEP 6 - NOTE FITMENT

## STEP 7 - DRILL AND INSTALL

DRILL OUT YOUR NEWLY MARKED HOLES USING AN 1/8" DRILL BIT. THEN USE A PHILLIPS HEAD SCREWDRIVER TO THREAD THE SUPPLIED STAINLESS STEEL SCREWS INTO YOUR DRILLED HOLES. MAKE SURE TO USE A WASHER BETWEEN THE REAR SPAT AND EACH SCREW.



## INSTALL COMPLETE!

WE LOVE TO SEE WHAT OUR CUSTOMERS DRIVE AND SHARE THEIR AWESOME BUILDS ON OUR SOCIAL MEDIA CHANNELS. TAG [@RENNWAGEN\\_USA](https://www.instagram.com/RENNWAGEN_USA) ON INSTAGRAM FOR A SHOUTOUT!