

FCC COMPLIANCE

NOTE: This equipment has been tested and found to comply with the limits for a Class B digital device, pursuant to Part 15 of the FCC Rules. These limits are designed to provide reasonable protection against harmful interference in a residential installation. This equipment generates, uses and can radiate radio frequency energy and, if not installed and used in accordance with the instructions, may cause harmful interference to radio communications. However, there is no guarantee that interference will not occur in a particular installation. If this equipment does cause harmful interference to radio or television reception, which can be determined by turning the equipment off and on, the user is encouraged to try to correct the interference by one or more of the following measures:

- Reorient or relocate the receiving antenna.
- Increase the separation between the equipment and receiver.
- Connect the equipment into an outlet on a circuit different from that to which the receiver is connected.
- Consult the dealer or an experienced radio/TV technician for help.

This device complies with Part 15 of the FCC Rules. Operation is subject to the following two conditions: (1) This device may not cause harmful interference, and (2) this device must accept any interference received, including interference that may cause undesired operation.

Caution: Modifications not authorized by the manufacturer may void users authority to operate this device.

CAN ICES-3 (B)/NMB-3(B).

LIMITED WARRANTY

The Little Tikes Company makes fun, high quality toys. We warrant to the original purchaser that this product is free of defects in materials or workmanship for one year * from the date of purchase (dated sales receipt is required for proof of purchase) and all other parts are free of defects in material or workmanship for 90 days*. At the sole election of The Little Tikes Company, the only remedies available under this warranty will be the replacement of the defective part or replacement of the product. This warranty is valid only if the product has been assembled and maintained per the instructions. This warranty does not cover abuse, accident, cosmetic issues such as fading or scratches from normal wear, or any other cause not arising from defects in material and workmanship.

*Trampoline Warranty:

We warrant to the original purchaser that the frame of this product is free of defects in materials or workmanship for 1 year from the date of purchase, and all other parts are free of defects in material or workmanship for 90 days from the date of purchase (dated sales receipt is required for proof of purchase).

U.S.A and Canada: For warranty service or replacement part information, please visit our website at www.littletikes.com, call 1-800-321-0183 or write to: Consumer Service, The Little Tikes Company, 2180 Barlow Road, Hudson OH 44236, U.S.A. Some replacement parts may be available for purchase after warranty expires—contact us for details.

Outside U.S.A and Canada: Contact place of purchase for warranty service. This warranty gives you specific legal rights, and you may also have other rights, which vary from country/state to country/ state. Some countries/states do not allow the exclusion or limitation of incidental or consequential damages, so the above limitation or exclusion may not apply to you.

PLEASE SAVE SALES RECEIPT FOR PROOF OF PURCHASE

Please keep this manual as it contains important information.



© The Little Tikes Company, an MGA Entertainment company.
LITTLE TIKES® is a trademark of Little Tikes in the U.S. and other countries. All logos, names, characters, likenesses, images, slogans, and packaging appearance are the property of Little Tikes.

0920-0-C

Little Tikes Consumer Service

2180 Barlow Road
Hudson, Ohio 44236 U.S.A.
1-800-321-0183

MGA Entertainment UK Ltd.

50 Presley Way, Crownhill, Milton Keynes,
MK8 0ES, Bucks, UK
support@LittleTikesStore.co.uk
Tel: +0 800 521 558

Printed in China

MGA Entertainment (Netherlands) B.V.

Baronie 68-70, 2404 XG Alphen a/d Rijn
The Netherlands
Tel: +31 (0) 172 758038
E-mail: klantenservice@mgaee.com

Imported by MGA Entertainment Australia Pty Ltd

Suite 2.02, 32 Delhi Road
Macquarie Park NSW 2113
1300 059 676



www.littletikes.com
www.littletikes.co.uk
www.littletikes.com.au

656071C

little tikes

ENG

3-6
years

Light-Up Trampoline

ASSEMBLY, INSTALLATION, CARE, MAINTENANCE AND USER INSTRUCTIONS

Adult assembly and supervision required. Approx. assembly time: 30 min.



Look for video of assembly at
littletikes.com/videoinstructions

Thank you for choosing the Little Tikes® Light-Up Trampoline.
 We strive to provide a durable, easy-to-assemble toys that's made to last, giving your child years of imaginative, engaging fun!

Really important information you should know!

Trampolines are great fun when used correctly. Most injuries are caused during the use of the trampoline, not because of their construction.

Read these instructions and warnings carefully and ensure you follow them at all times. Follow all assembly and maintenance instructions closely to ensure the equipment is safe to use and lasts as long as possible.

- You must thoroughly read this manual before assembling and using this trampoline.
- Clear a flat surface to lay out all the materials so everything is close at hand.
- The parts are listed - each part is identified with a letter in RED for easy reference.
- Illustrations are for reference only. Styles may vary from actual contents.
- **If you have any questions, we're here to help. Give our customer service team a call at 1-800-321-0183.**

⚠ WARNING: GENERAL **ADULT ASSEMBLY AND SUPERVISION REQUIRED**

Read all instructions before using the trampoline. Warnings and instructions for the care, maintenance, and use of this trampoline are included to promote safe, enjoyable use of this equipment.

- Save this manual for future reference.
- Prior to assembly, this package contains small parts: hardware which is a choking hazard and may contain sharp points. Keep away from children until assembled.
- This trampoline is only suitable for domestic indoor use.
- The trampoline is not intended to be buried in the ground.
- Adult supervision required. Do not leave children unattended.
- Do not allow young children to use unless supervised by an adult.
- This product is intended for children 3 - 6 years of age and is not intended for use by children under 3 years of age due to their inability to use safely. Not recommended for children over 6 years of age.
- Limit one child at a time. Max. weight limit: 55 lbs. (25 kgs).
- The trampoline is designed for installation on flat surfaces with at least 2m clear space around the trampoline. Place the trampoline away from all objects such as walls, fences, structures, furniture and other objects.
- Do not place on a hard surface (i.e. concrete or asphalt) serious injury may occur.
- Ensure there is 3m (9.8 ft) of clear area above the trampoline as measured from the trampoline surface. This area should be free of objects such as wires, ceiling fans, branches, and other possible hazards.
- Ensure area under the bouncing surface is free of objects.
- Inspect the trampoline before each use. Make sure the frame padding is correctly and securely positioned. Replace any worn, defective, or missing parts.

12 Folding and Storing...

⚠ WARNING:

Perform a complete inspection of the trampoline to make sure all parts are assembled and attached properly.

Read this entire manual and make sure all jumpers completely understand all of the safety rule printed in the manual and on the various warning signs.

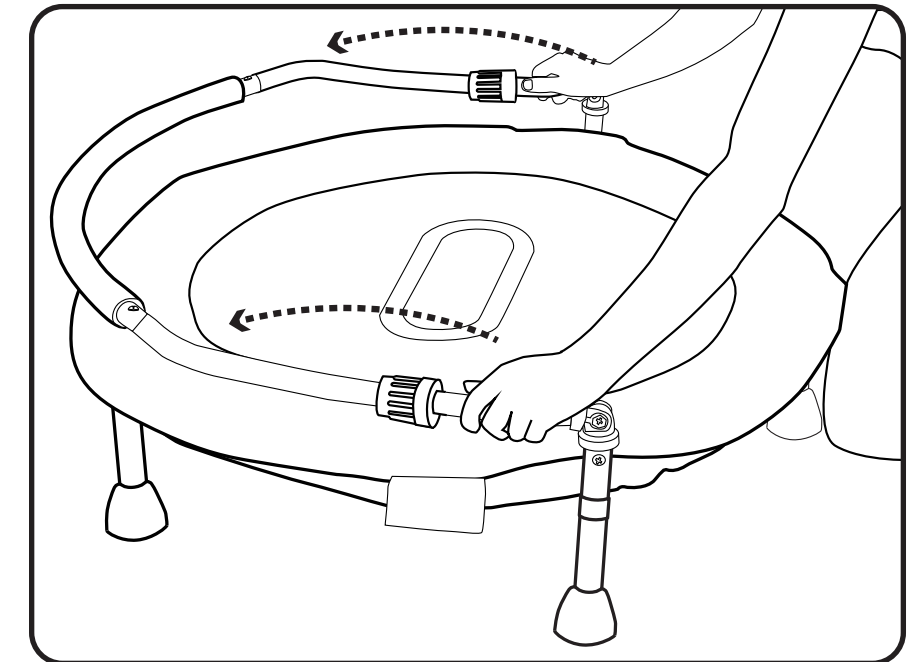
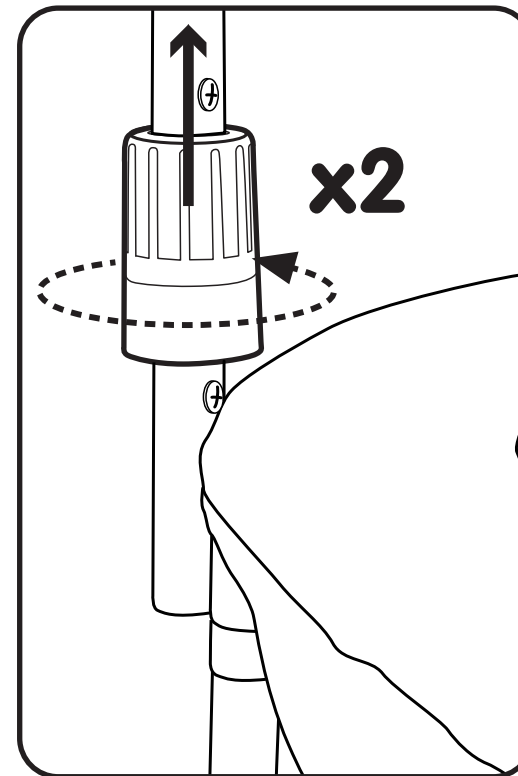



Jump and dance all night long!

When the switch is in the “Bounce Activation” position (all the way to the left), the lights will activate only when the child is bouncing.

When the switch is in the “On” position (all the way to the right), the lights will run continuously.

To Select a Mode:

1. The switch must be in the “On” position.
2. Press the “Modes” button the number of times indicated to the left of the selection you want to activate.

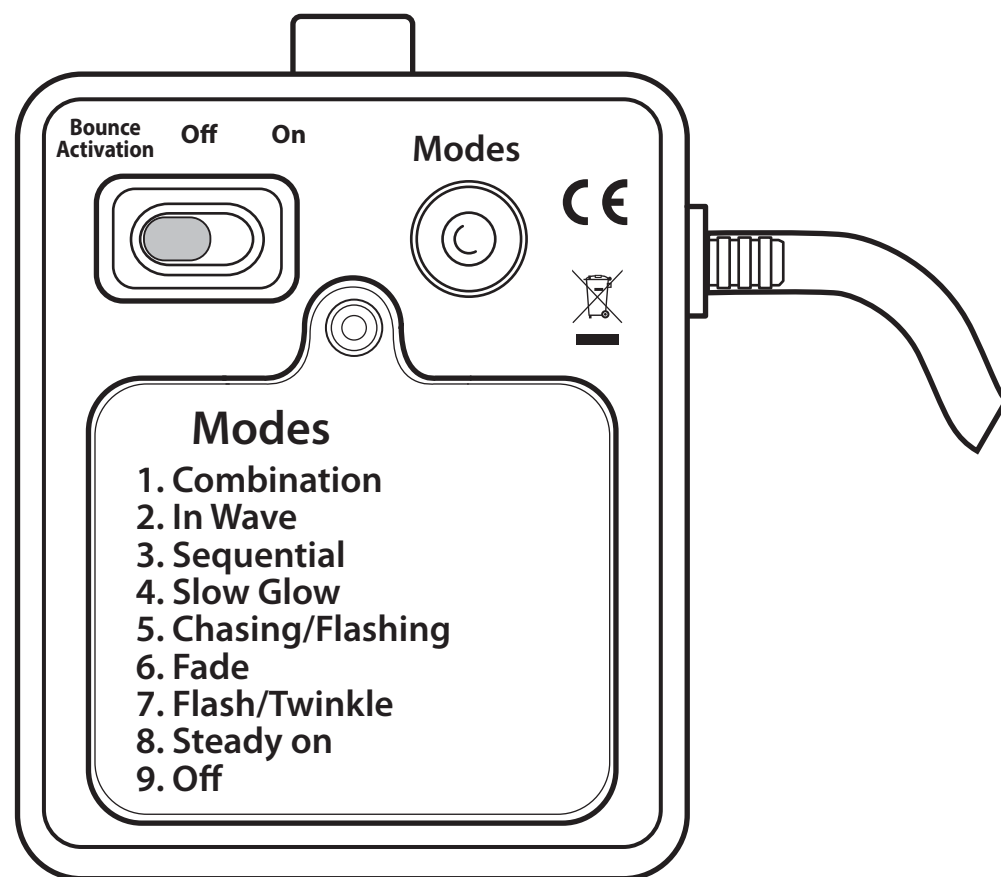

WARNING: USAGE

- Do not attempt stunts including somersaults, serious injury may occur if stunts are attempted on this trampoline. Landing on the head or neck can cause serious injury, paralysis or death, even when landing in the middle of the bed.
- Children and unpracticed users must always jump under supervision by an experienced person, it is strongly recommended to use spotters at all times.
- Do not allow more than one person on the trampoline. Use by more than one person at the same time can result in serious injury.
- Only one user. Collision hazard.
- Do not eat while jumping.
- Use trampoline only with mature, knowledgeable supervision.
- Remove glasses, watches, jewelry and chains, ornaments, clasps and other sharp objects. Empty your pockets before starting to jump.
- Do not use the trampoline in the dark.
- Do not put any objects or toys on the trampoline.
- Do not use when wet.
- Jumpers must wear socks, gymnastic shoes, or be barefoot when using the trampoline. Please be aware that street shoes or tennis shoes should NOT be worn while using the trampoline.
- Jumpers should remove all sharp objects prior to using the trampoline. Any type of sharp or pointed objects should be kept off the trampoline mat at all times.
- To break a bounce, all you need to do is flex your knees sharply before they come in contact with the mat of the trampoline. This technique should be practiced while you are learning each of the basic bounces. The skill of braking should be used whenever you lose balance or control of your jump.
- Misuse and abuse of this trampoline is dangerous and can cause serious injury! Trampolines being a rebounding device, propel the performer to unaccustomed heights and into a variety of body movements.
- Always inspect the trampoline before each use for worn-out mat, loose or missing parts.
- Climbing on and off the trampoline: it is a dangerous practice to jump from the trampoline to the floor or ground when dismounting, or to jump onto the trampoline when mounting. Do not use the trampoline as a springboard to other objects.
- Avoid bouncing too high. Stay low until bounce control and repeated landing in the center of the trampoline can be accomplished. Control is more important than height.
- While keeping the head erect, focus eyes on the trampoline toward the perimeter. This will help control bounce.
- Keep objects away which could interfere with the performer. Maintain a clear area around the trampoline.
- Bounce only when the surface of the bed is dry. Wind or air movement should be calm and gentle. The trampoline must not be used in gusty or severe winds.
- Bounce in the center of the bed.
- Secure the trampoline against unauthorized use.
- Limit the time of continuous usage (make regular stops).
- Modifications made by the consumer to the original trampoline (e.g. the adding of an accessory) shall be carried out according to the instructions of the manufacturer.
- Make sure that the hook-and-loop fasteners are closed correctly during use of trampoline.

Care, maintenance and use instructions

MUST be read carefully before using the trampoline!

This trampoline was designed and manufactured with quality materials and craftsmanship. If proper care and maintenance is provided, it will provide all jumpers with years of exercise, fun, and enjoyment as well as reduce the risk of injury. Please follow the guidelines listed below:

- Please make sure that only one person at any one time uses the trampoline.
- In order to prevent the trampoline mat from getting cut or damaged please do not allow any pets onto the mat.
- Always inspect the trampoline before each use for worn, abused or missing parts. A number of conditions could arise that may increase your chances of getting injured.

Please be aware of:

- Punctures, holes, or tears in the trampoline mat
- Sagging trampoline mat
- Loose stitching or any kind of deterioration of the mat
- Bent or broken frame parts, such as legs or poles
- Damaged, missing, or insecurely attached frame pad
- Protrusions of any types (especially sharp) on the frame, springs, or mat.

IF YOU FIND ANY OF THE PREVIOUS CONDITIONS, OR ANYTHING ELSE THAT YOU FEEL COULD CAUSE HARM TO ANY USER, THE TRAMPOLINE SHOULD BE DISASSEMBLED OR SECURED FROM USE UNTIL THE CONDITION(S) HAS BEEN RESOLVED.

Carry out checks and maintenance of the main parts (frame, suspension system, bed, pads and enclosure) at regular intervals. If these checks are not carried out the trampoline could become dangerous.

It is of particular importance that these be followed at the beginning of each season, as well as at regular intervals during the usage season.

- Check all nuts and bolts for tightness and tighten when required.
- Check all coverings for bolts and sharp edges and replace when required.
- Check for evidence of wear or deterioration and replace if needed in accordance with these instructions.

Battery Safety Information. This is serious!

- Keep these instructions for future reference.
- The voltage of a fully-charged, rechargeable battery is often lower than that of a fresh alkaline battery. Therefore it is recommended that alkaline batteries be used instead of rechargeable batteries for best performance and longer play time.
- Install batteries with the correct polarity (+ and -).
- Use only size "AA" (LR6) alkaline batteries (3 required).
- Charging of rechargeable batteries should only be done under adult supervision.
- Remove rechargeable batteries from the product before recharging.
- Do not mix old and new batteries.
- Do not mix alkaline, standard (carbon-zinc), or rechargeable batteries.
- Be sure to insert the batteries correctly and follow the toy and battery manufacturer's instruction.
- Always remove exhausted or dead batteries from the product.
- Dispose of dead batteries properly: do not burn or bury them.
- Do not attempt to recharge non-rechargeable batteries.
- Avoid short-circuiting battery terminals.
- Remove batteries before placing the unit into storage for a prolonged period of time.

NOTE: If the unit stops working or doesn't work as it should, remove the batteries for a few minutes and then re-insert them. If there is still a problem, install new batteries.

10 Time to LIGHT IT UP!

Follow steps A and B to attach the Light-up box (part O) to the folding leg closest to the colored tab.

WAIT!
You installed the batteries- right?

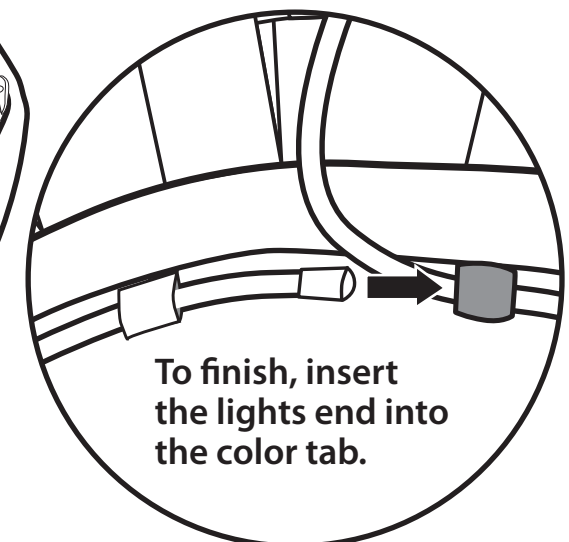
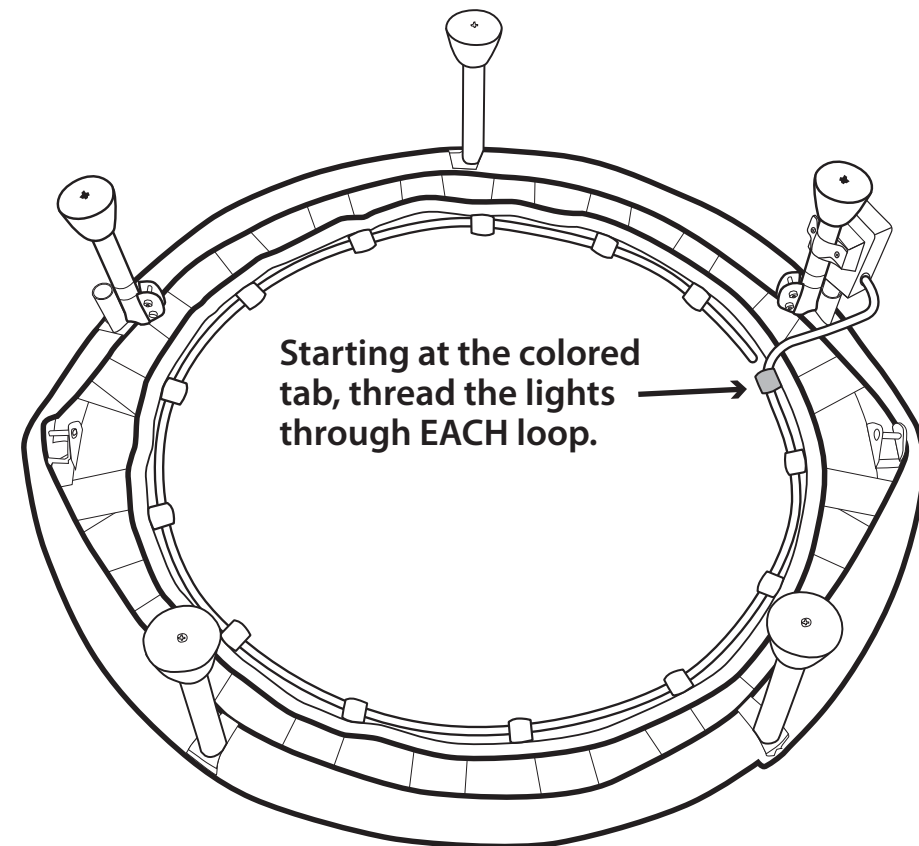
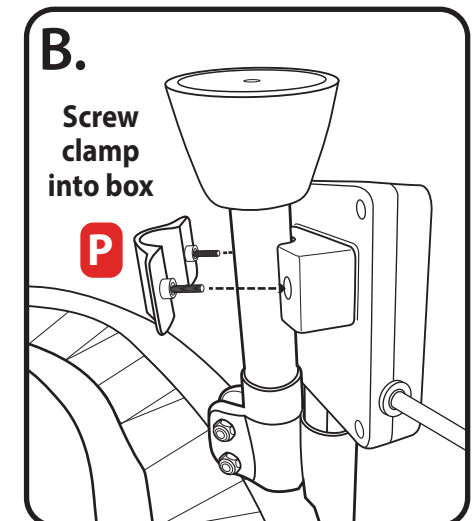
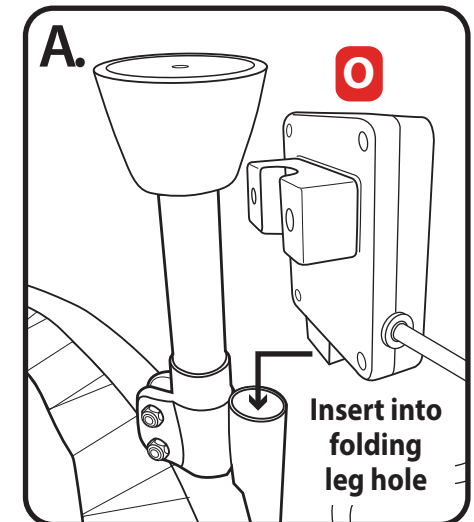
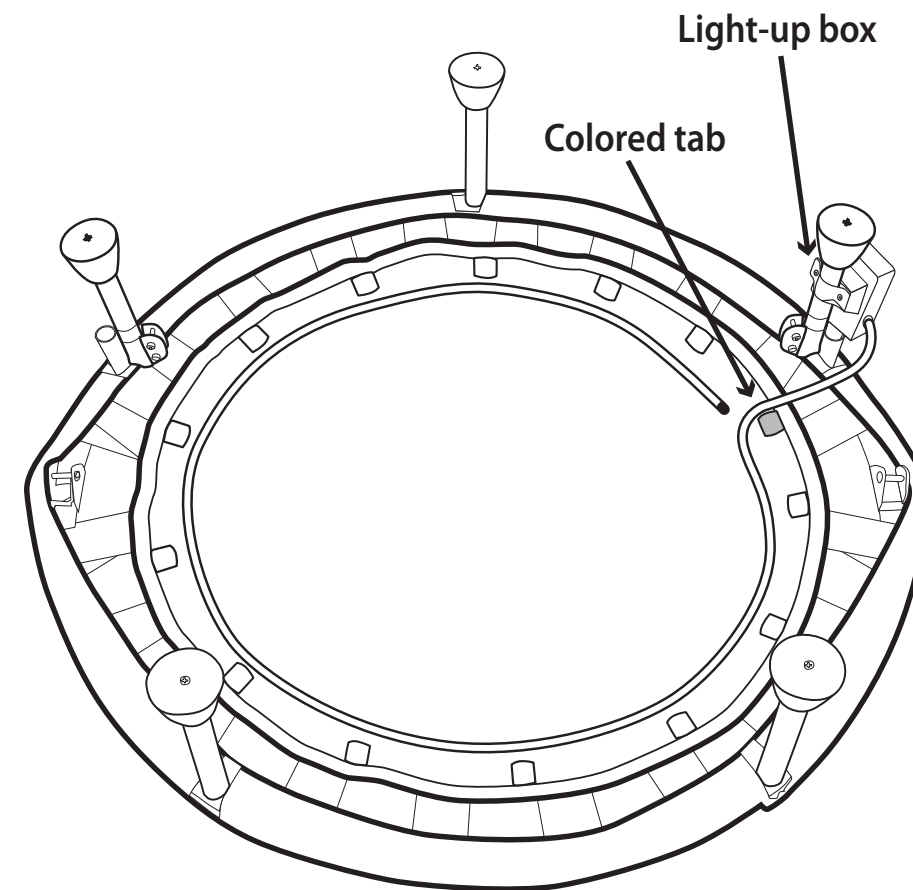

8 Almost finished....

Use the wrench (part M) to tighten the nuts on each folding safety bar.

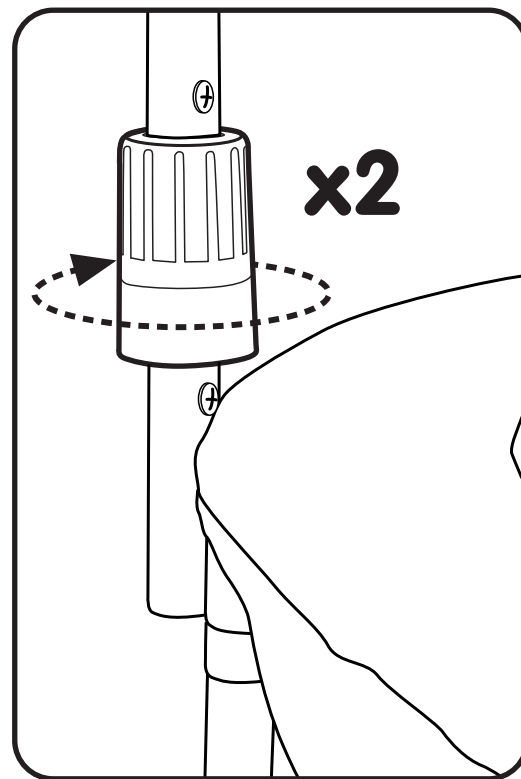
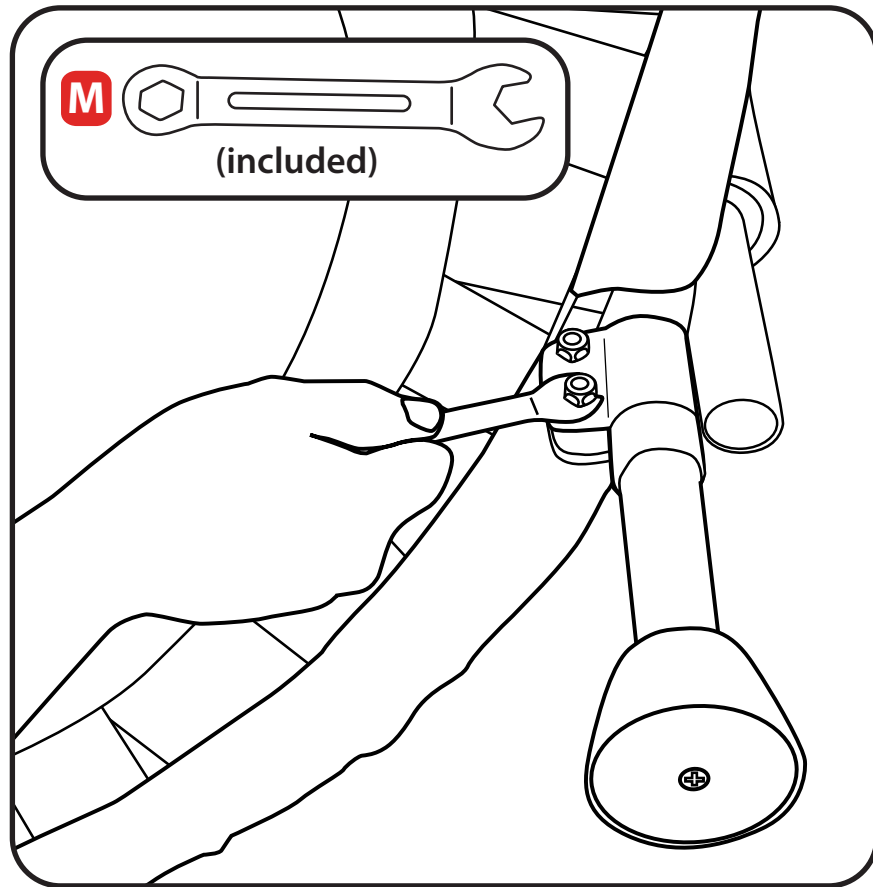

Twist clockwise to lock the safety bar in the upright position.

9 Battery installation....

Before playing, an adult must install fresh alkaline batteries in the Light-Up Trampoline. Here's how:

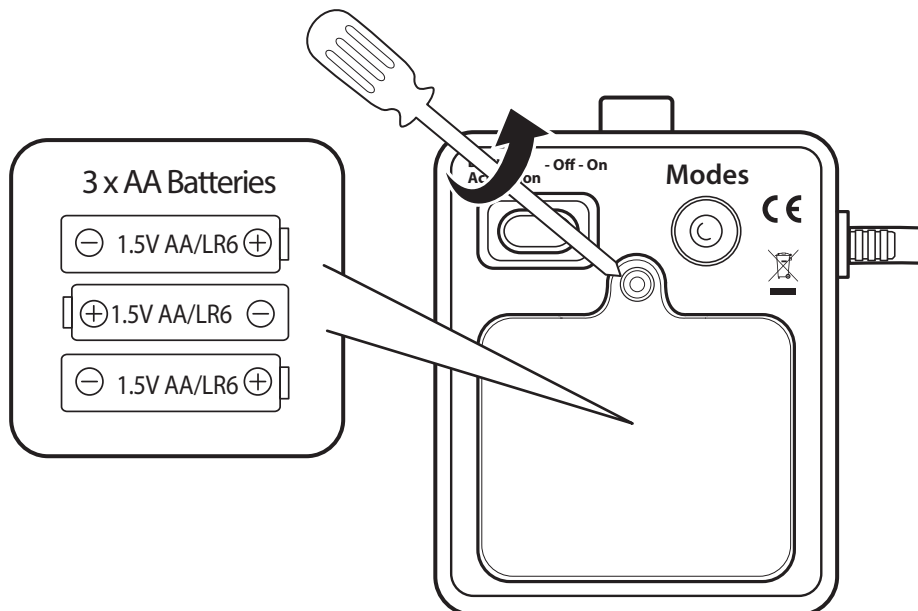

1. Using a Phillips screwdriver (not included) remove the screw and battery compartment cover from the Light-up box.
2. Install three (3) fresh 1.5V AA (LR6) alkaline batteries (not included) making sure the (+) and (-) ends face the proper direction as indicated inside the battery compartment.
3. Replace the compartment cover and tighten screw.

A Few Things Before You Start!

BEFORE you begin assembly, make sure you have all the parts listed below.

! Some packages of hardware may have extra pieces.

! Questions? We're here to help.

Little Tikes customer service team at 1-800-321-0183.

<p>A Trampoline Mat & Frame (1)</p>	<p>H 1 1/2" Bolts (2)</p>
<p>B Frame Legs (3)</p>	<p>I 1/2" Screws (2)</p> <p>J Cap Nuts (2)</p>
<p>C Folding Handle Legs (2)</p>	<p>K Big Spring Ring (2)</p> <p>L Small Spring Ring (2)</p>
<p>D Leg Stops (5)</p>	<p>M Wrench (1)</p>
<p>E Curved Safety Bar with Foam (1)</p>	<p>N Screwdriver (1)</p>
<p>F RIGHT Safety Bar (1)</p> <p>Color dot</p>	<p>P Light-up module clamp (1)</p> <p>O Light-up module with lights (1)</p>
<p>G LEFT Safety Bar (1)</p> <p>Color dot</p>	

1 Let's get started...opening the trampoline

- Always use 2 or more strong adults to perform this step and keep your face away from the rails. Failure to do so may allow the rails to spring back into the folded position and cause harm.
- Keep fingers away from the end of the rails near the hinged area when unfolding the trampoline.
 1. Gather a nut (J), bolt (H), and bif spring ring (K) and place next to each hinge on the floor PRIOR to unfolding the trampoline.
 2. Lay the folded trampoline on the floor, in its still folded position.
 3. Hold one side down firmly.
 4. Using steady pressure, with hands open and fingers extended, pull on the other side to open.
 5. Open the trampoline fully, until hinges snap into place.

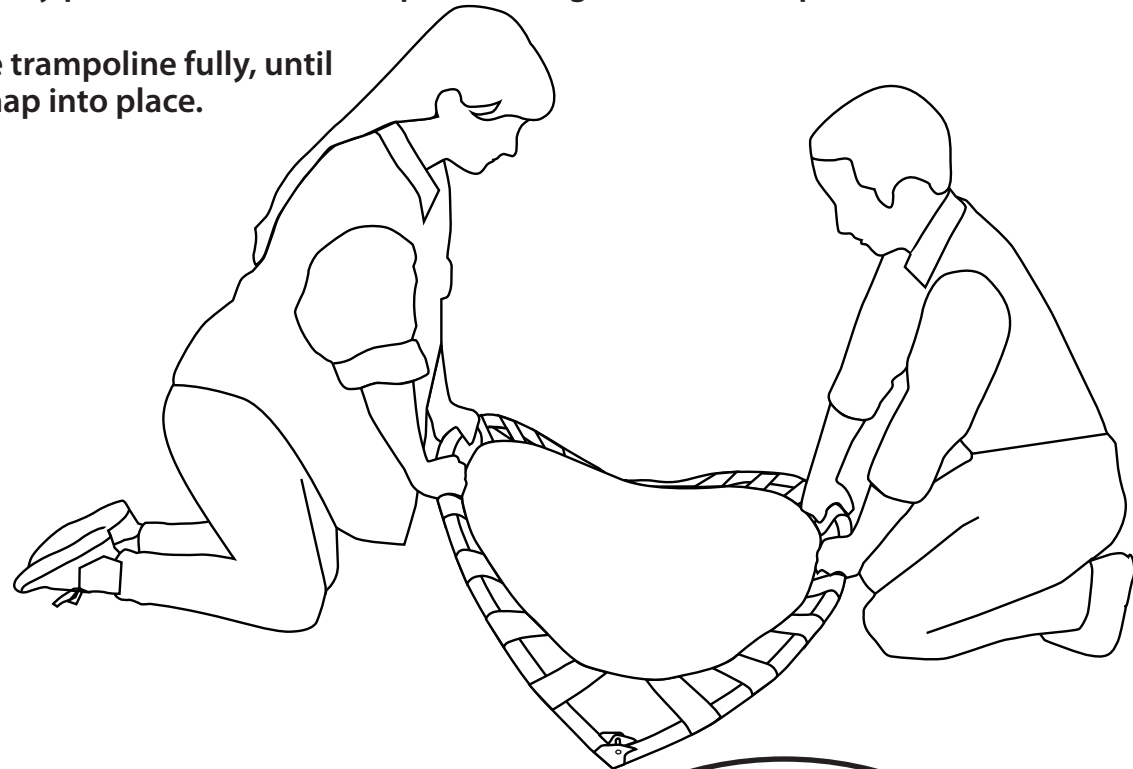

WARNING:
Adult assembly
required.

Impact hazard exists until hardware is installed. Keep face and arms away until hardware is installed. Do NOT leave trampoline unfolded without completely installing the bolts according to the instructions.

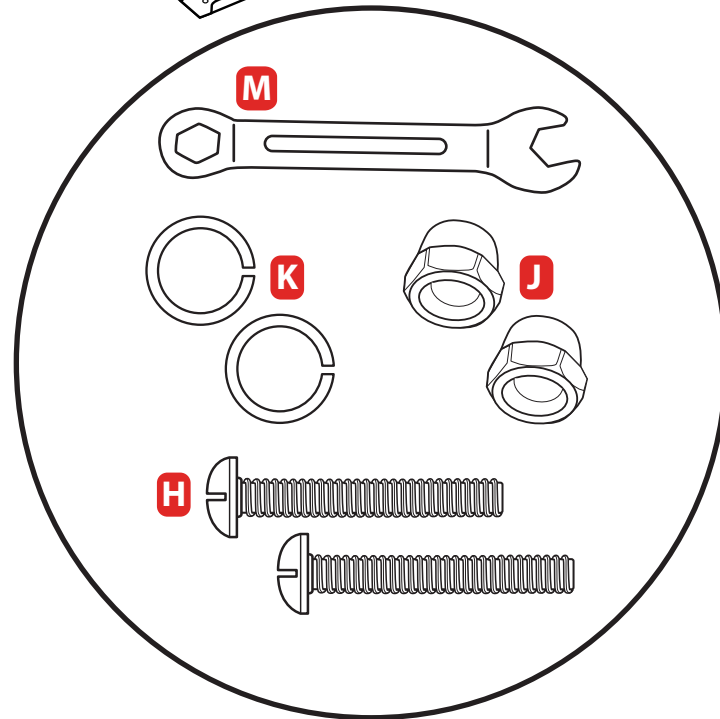

7 Finish with the safety bars!

Stand the trampoline on its legs. Place the curved safety bar with foam (part E) onto each end of the RIGHT and LEFT safety bars.

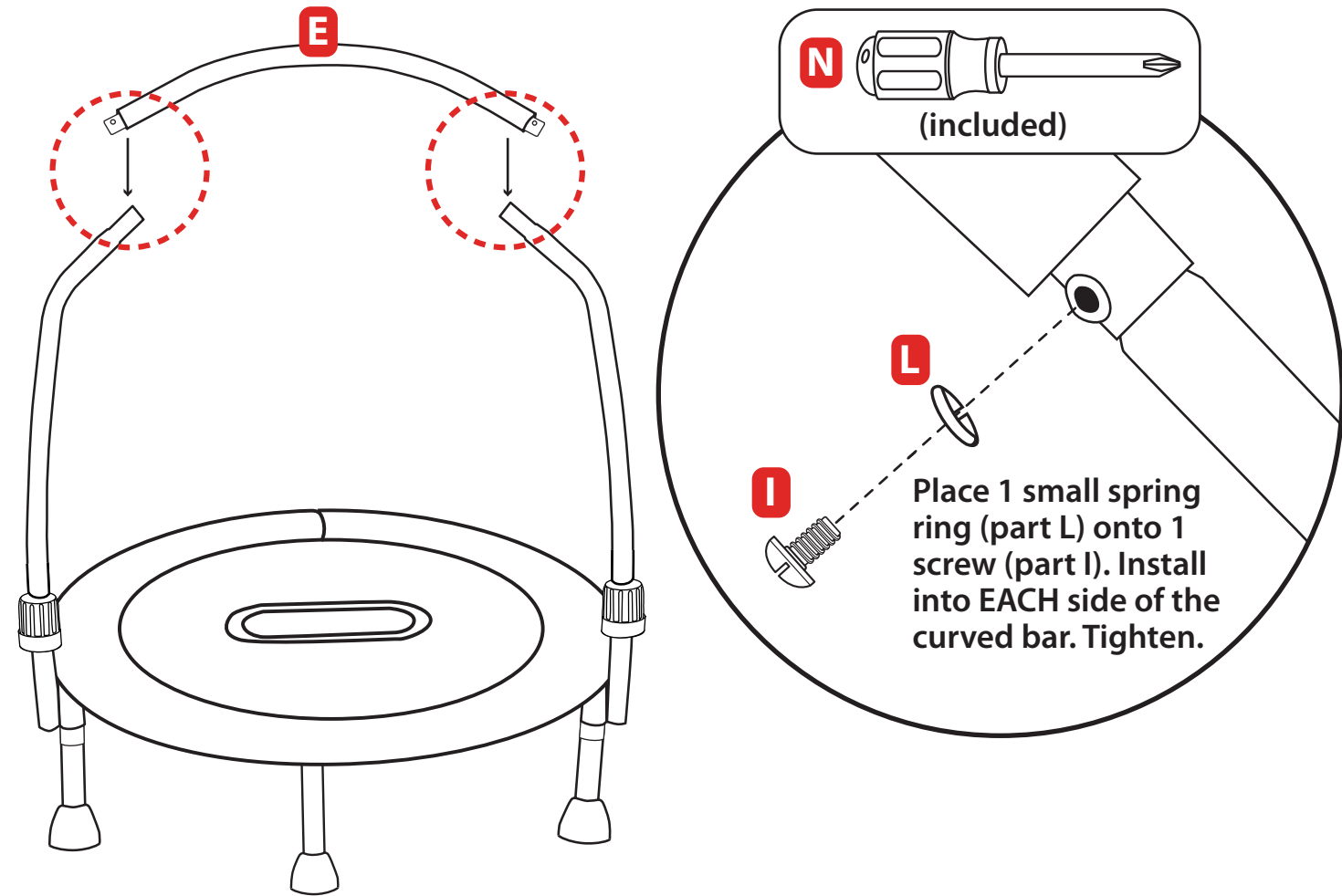

Safety Bars should curve outward.

If the safety bars DO NOT Curve outward they have been installed incorrectly - on the wrong side. Re-install the safety bars in the correct position.

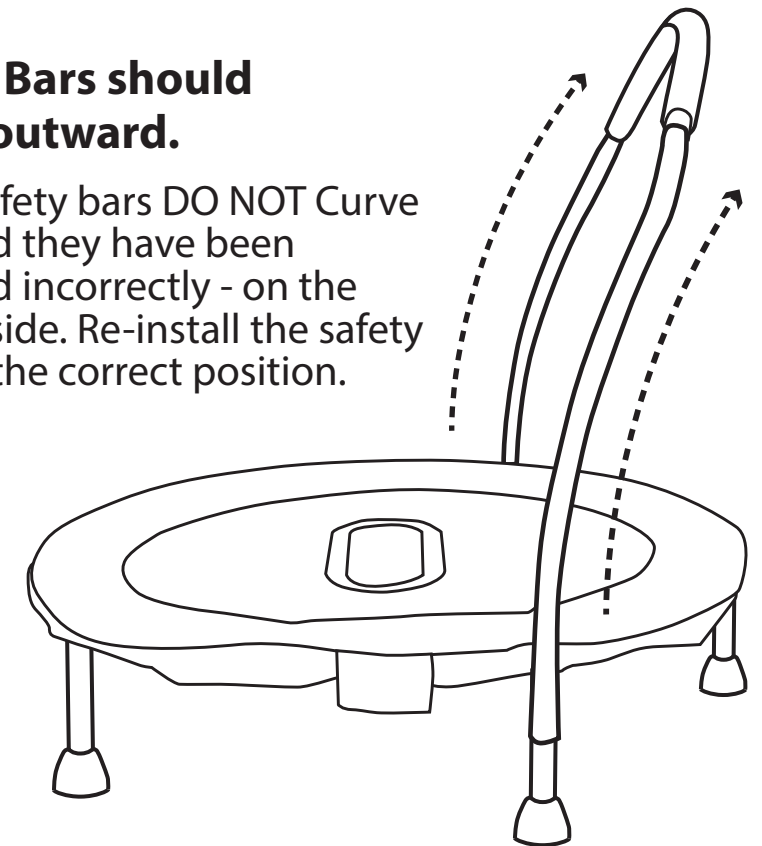

6 Folding handle legs...match it up!

Match the color dots on the RIGHT and LEFT safety bars (part F & G) to the color dots on the trampoline frame.

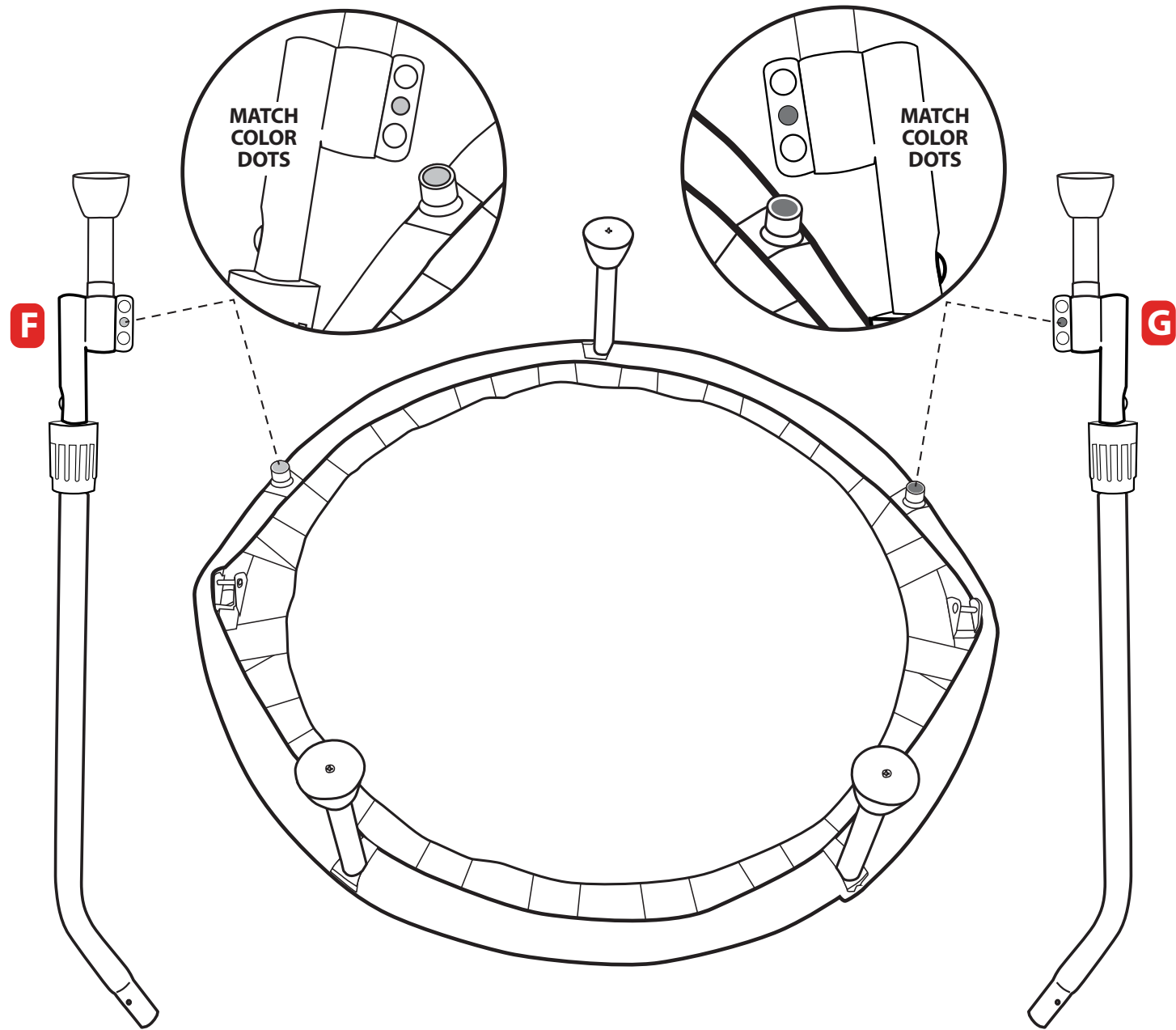

Once you've matched the color dot to the correct leg position, insert the safety bar onto the trampoline and turn the folding handle leg to tighten.

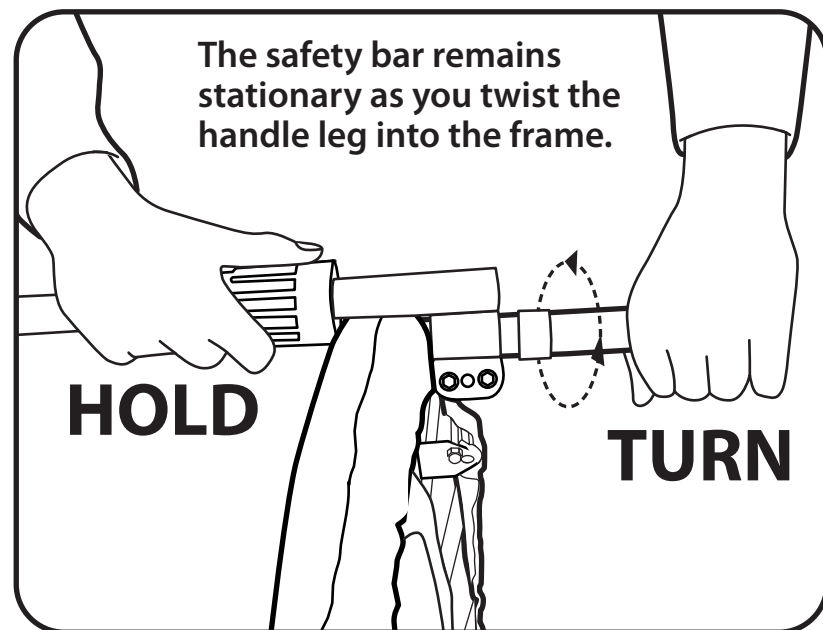

2 Make sure it's hinged...

Insert 1 1/2" bolt (part H) through the hinge. Place (1) big spring ring (part K) onto the end of the bolt.

Place (1) cap nut (part J) onto the end of each bolt.

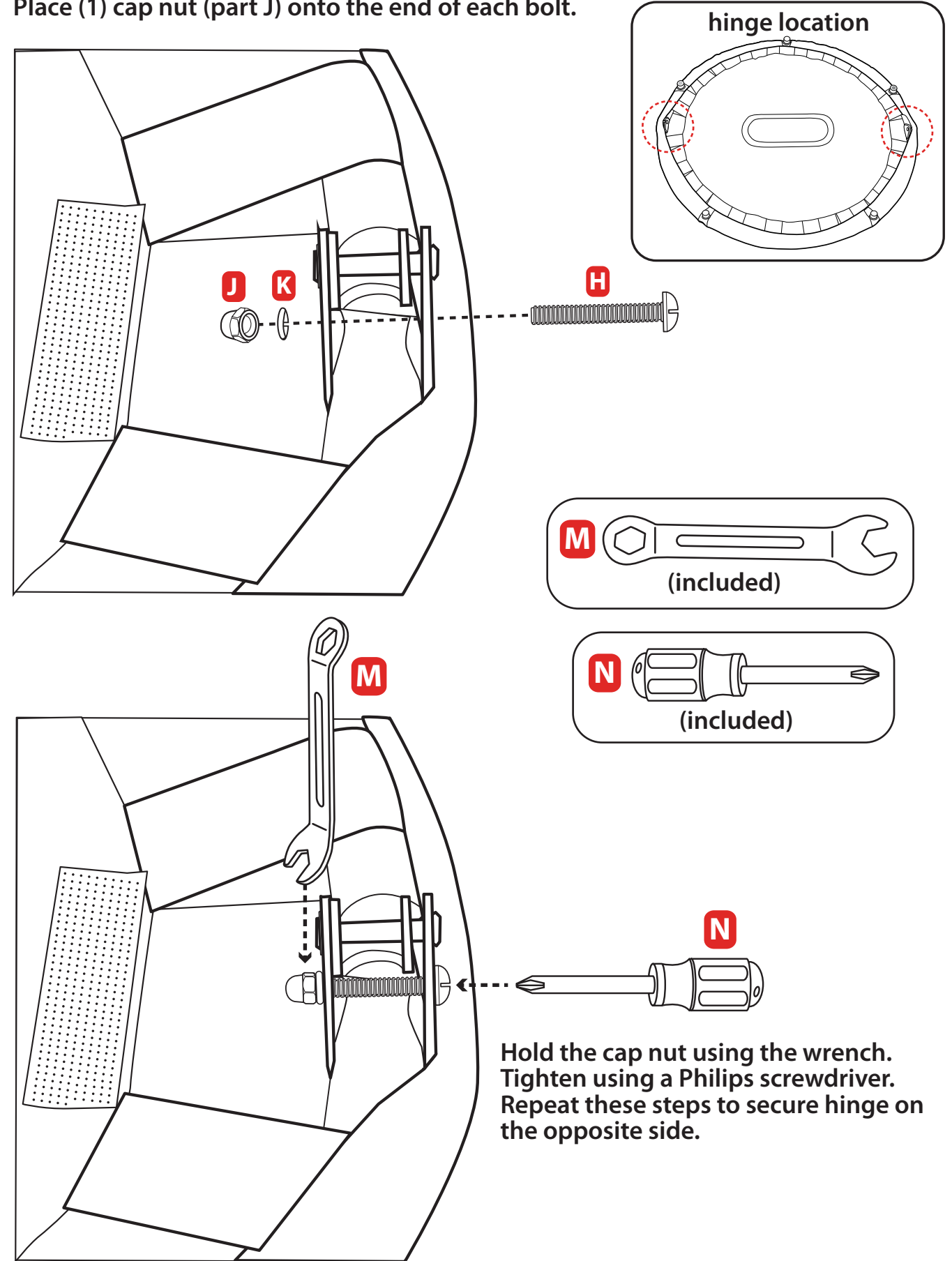

Hold the cap nut using the wrench. Tighten using a Philips screwdriver. Repeat these steps to secure hinge on the opposite side.

3 Uncap and Pull...

Remove all protective end caps from screw threads and discard. Keep out of reach of children.

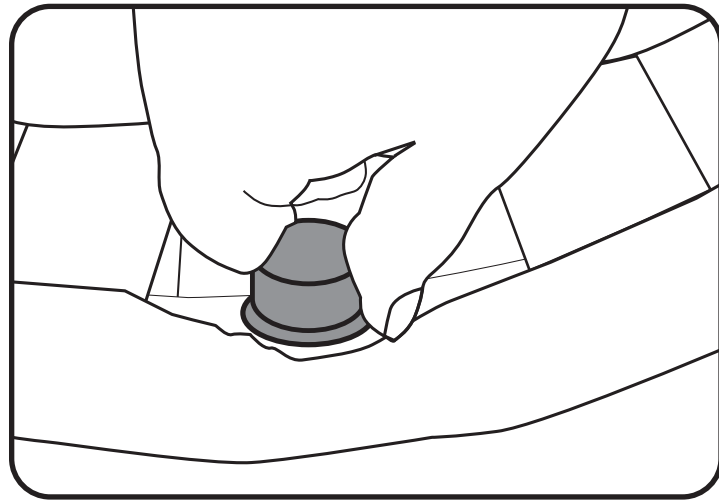

Pull the elastic band over all the screw threads.

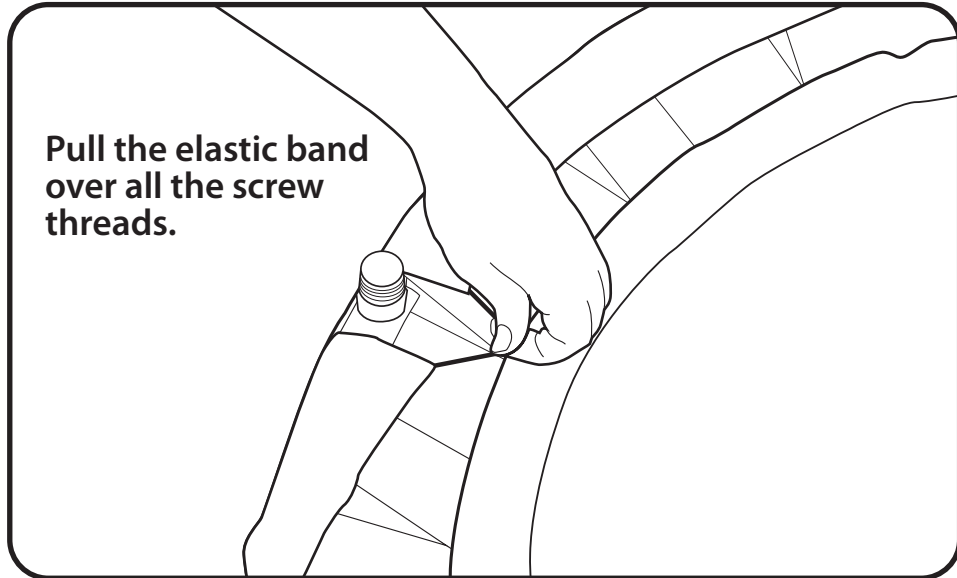

4 Get a Leg Up!

Attach a leg stop (part D) to each of the (3) frame legs (part C).

Attach a leg stop (part D) to each of the (2) folding handle legs (part B).

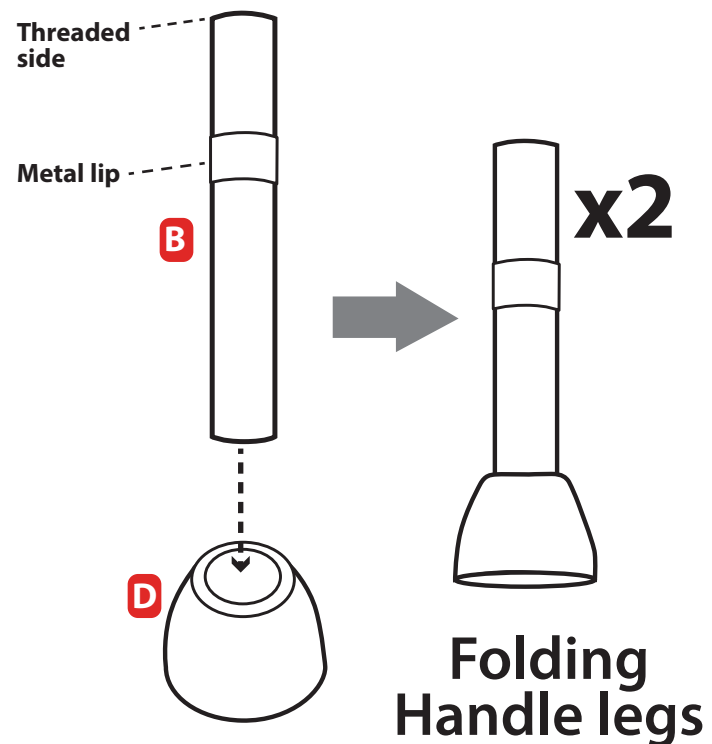
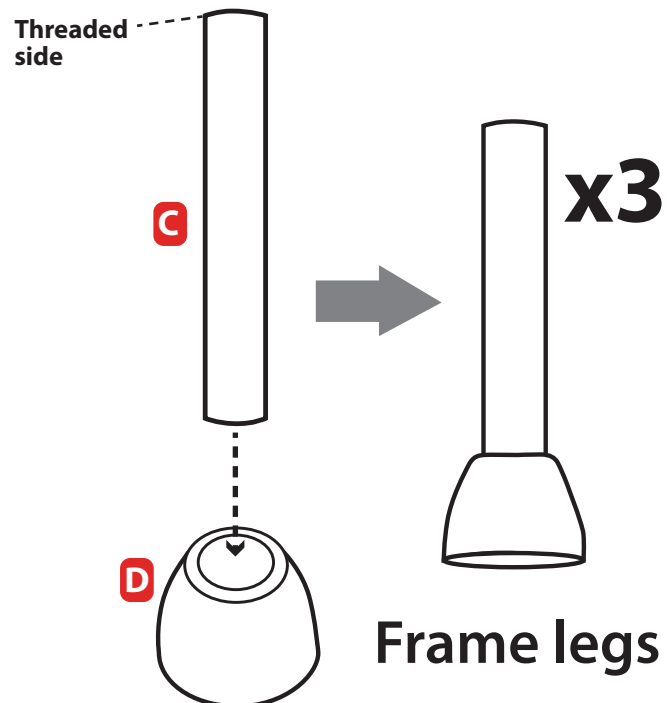

5 Easy peasy...frame legs go first

Start with the 3 FRAME LEGS (part C). These are the legs with NO METAL LIP. Thread them onto the trampoline frame in the locations with NO COLOR DOTS.

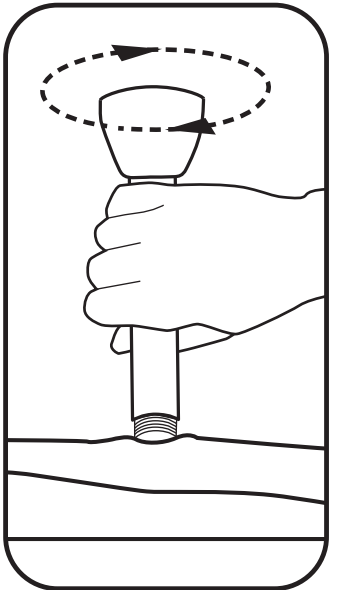
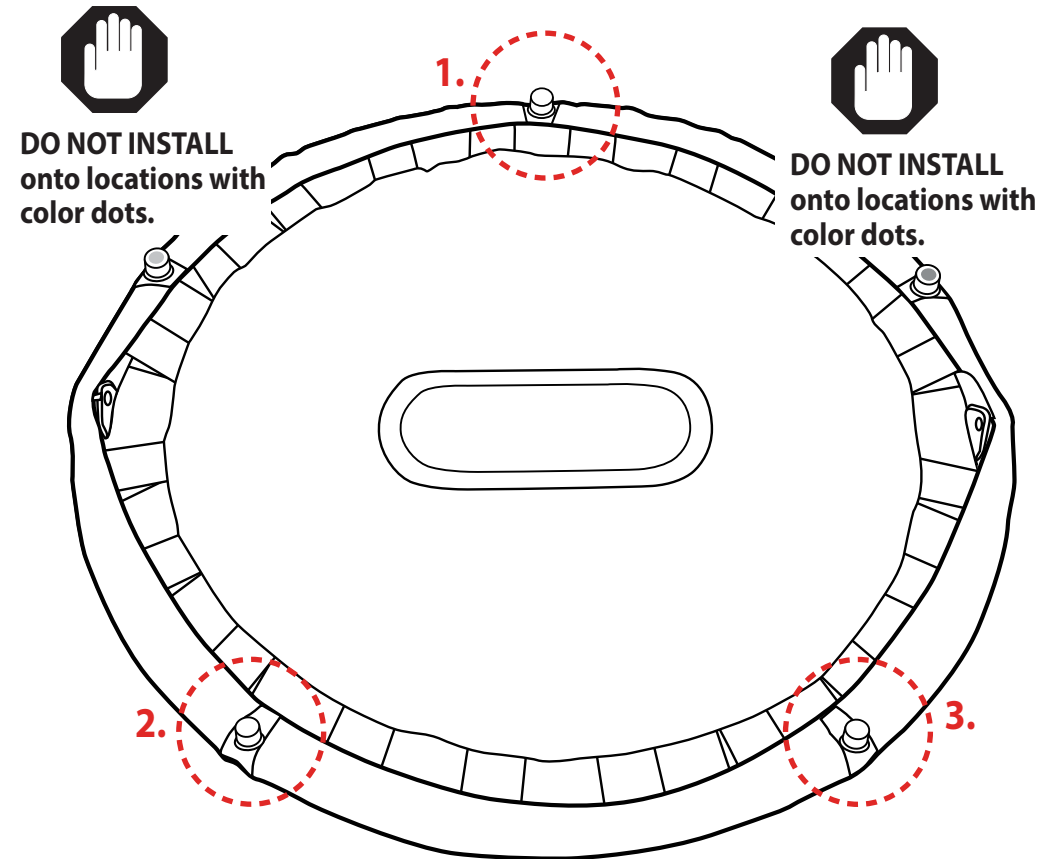

Twist clockwise until COMPLETELY TIGHT.

6 Folding handle legs...match it up!

Insert a folding handle leg (part C) into the end of EACH safety bar.

