

LIMITED WARRANTY

The Little Tikes Company makes fun, high quality toys. We warrant to the original purchaser that this product is free of defects in materials or workmanship for one year * from the date of purchase (dated sales receipt is required for proof of purchase). At the sole election of The Little Tikes Company, the only remedies available under this warranty will be the replacement of the defective part or replacement of the product. This warranty is valid only if the product has been assembled and maintained per the instructions. This warranty does not cover abuse, accident, cosmetic issues such as fading or scratches from normal wear, or any other cause not arising from defects in material and workmanship. *The warranty period is three (3) months for daycare or commercial purchasers.

U.S.A and Canada: For warranty service or replacement part information, please visit our website at www.littletikes.com, call 1-800-321-0183 or write to: Consumer Service, The Little Tikes Company, 2180 Barlow Road, Hudson OH 44236, U.S.A. Some replacement parts may be available for purchase after warranty expires—contact us for details.

Outside U.S.A and Canada: Contact place of purchase for warranty service. This warranty gives you specific legal rights, and you may also have other rights, which vary from country/state to country/state. Some countries/states do not allow the exclusion or limitation of incidental or consequential damages, so the above limitation or exclusion may not apply to you.



Pack 'n Go
3-in-1 Trike™

ENG

645747C
AGES: 12 MONTHS - 5 YEARS

ADULT ASSEMBLY AND SUPERVISION REQUIRED

CONTENTS

REQUIRED TOOLS FOR ASSEMBLY (NOT INCLUDED)

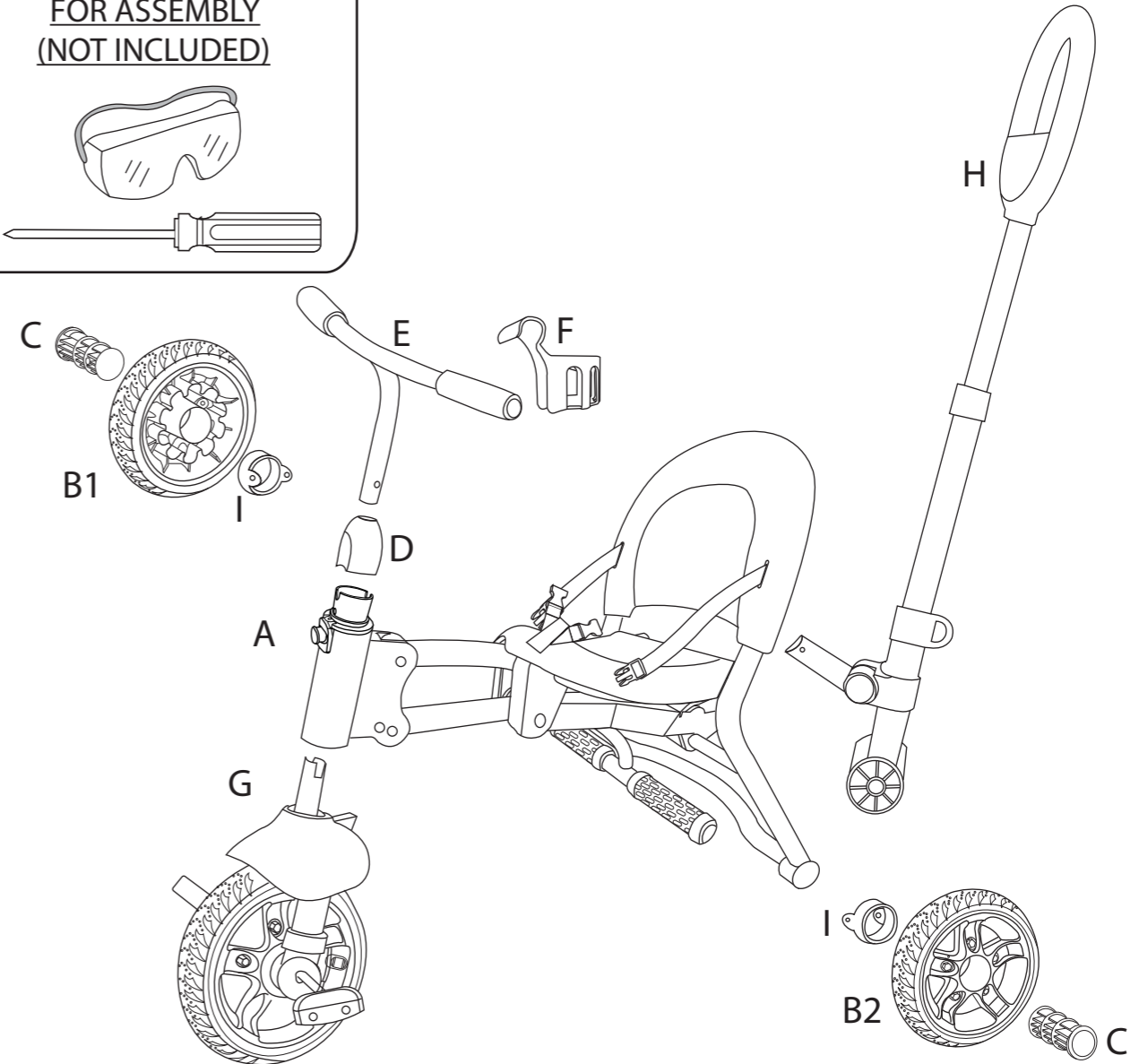
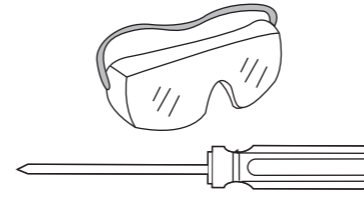

INCLUDED HARDWARE

J1 x 4 (for B1, B2) K1 x 1 (for E) J2 x 1 (for D)

L1 x 1 (for H) L2 x 1 (for H)

M1 x 2 (for H)

x 2

Please keep this manual as it contains important information.



1217-0-C

© The Little Tikes Company,
an MGA Entertainment company.
LITTLE TIKES® is a trademark of Little Tikes in
the U.S. and other countries. All logos, names,
characters, likenesses, images, slogans, and
packaging appearance are the property of
Little Tikes.

Little Tikes Consumer Service
2180 Barlow Road Hudson, Ohio 44236 U.S.A.
1-800-321-0183

Printed in China

MGA Entertainment UK Ltd
50 Presley Way
Crownhill
Milton Keynes
MK8 0ES
Bucks, UK
0800 521 558

www.littletikes.com
www.littletikes.co.uk



Visit our website at
www.littletikes.com
to register your product and
to enter our sweepstakes.
(No purchase necessary)



PLEASE READ INSTRUCTIONS
BEFORE ASSEMBLING AND OPERATING.

Please save sales receipt for proof of purchase.

⚠ WARNING: ADULT ASSEMBLY REQUIRED.

- Read entire instructions carefully before assembling this product.

⚠ WARNING: ASSEMBLY

- Keep these instructions for future reference.
- Prior to assembly, this package contains small parts: hardware which is a choking hazard and may contain sharp edges and sharp points. Keep away from children until assembled.
- Ensure working area is free of danger. Always dispose of packaging material in such a way that it may not cause any harm. Plastic bags can be dangerous. To avoid suffocation, keep plastic bags away from babies and children.
- To prevent serious injury, children must not use the equipment until completely assembled.
- This product is intended for outdoor domestic family use only.
- This product is for private, residential use only (no commercial or public use).
- Adult assembly required. Choking hazard to children under the age of 3 years - contains small parts prior to assembly.

ASSEMBLY HINT

Assemble all parts together loosely at first. Check that assembly is correct, then tighten all screws.

⚠ WARNING: TO AVOID SERIOUS INJURY:

- Continuous adult supervision required.
- Never use near motor vehicles.
- Never use near streets, swimming pools, hills, steps, or sloped driveways.
- Always wear closed shoes when using the tricycle.
- Never allow more than one rider on the tricycle.
- Instruct children on proper use of this product before allowing them to ride.
- This product is not to be used in a manner other than for which it is intended.
- Only ride the trike once it is fully unfolded.
- DO NOT sit or ride on the trike in the folded position.
- It is recommended that rider always wear a properly fitted helmet that complies with U. S. Consumer Product Safety Commission (CPSC) standard 16 CFR 1203.
- Ride-on toys should be used with caution since skill is required in order to avoid falls or collisions which may cause injury to the user or third parties.

⚠ WARNING! Not to be used by children over the age of five (5) years due to size limitation.

- Intended for children 12 months to 5 years.
- Maximum child's weight: 50 lbs. (23 kg).
- Safeguard the product against rolling away when parking it.

MAINTENANCE & CLEANING

- Check all hardware during usage period and tighten as required. It is particularly important that this procedure be followed at the beginning of each season. If these checks are not carried out, the toy could overturn or otherwise become a hazard.
- Do not attempt to modify or repair this product. For help contact Little Tikes Consumer Service.
- Clean trike with a slightly damp cloth (cold water) and mild soap. Never use a corrosive or abrasive substance to clean the product.

DISPOSAL

- Disassemble and dispose of equipment in such a manner that no hazardous conditions, such as but not limited to, small parts and sharp edges, exist at the time equipment is discarded.

4. Unhook the strap. Then, pull the safety pin out to unlock and pull the strap up to fold the trike. Push pin back in.

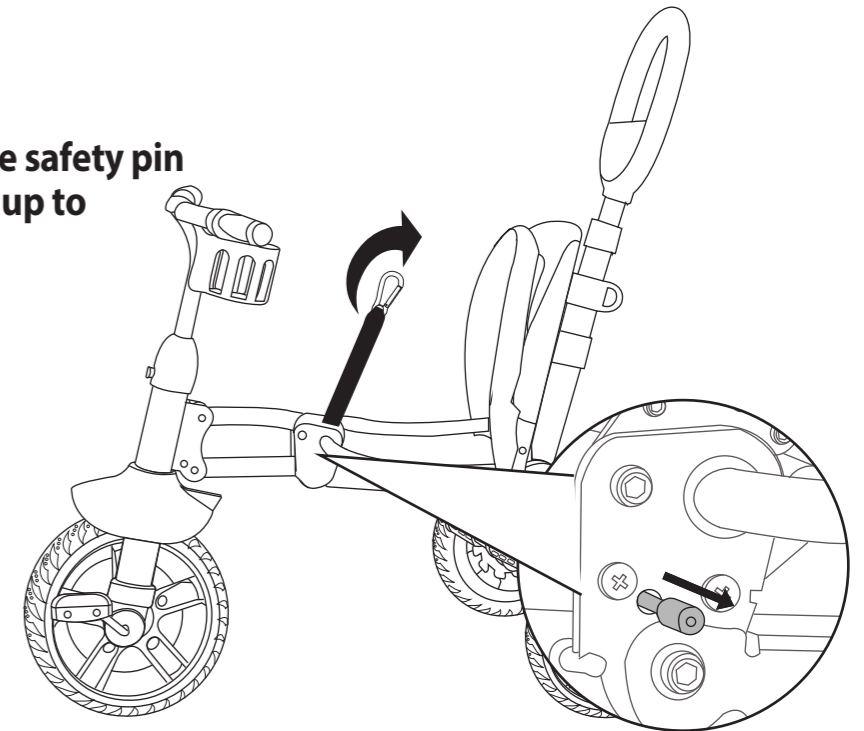

5. Attach the snap hook on the strap to the loop on the parent handle.

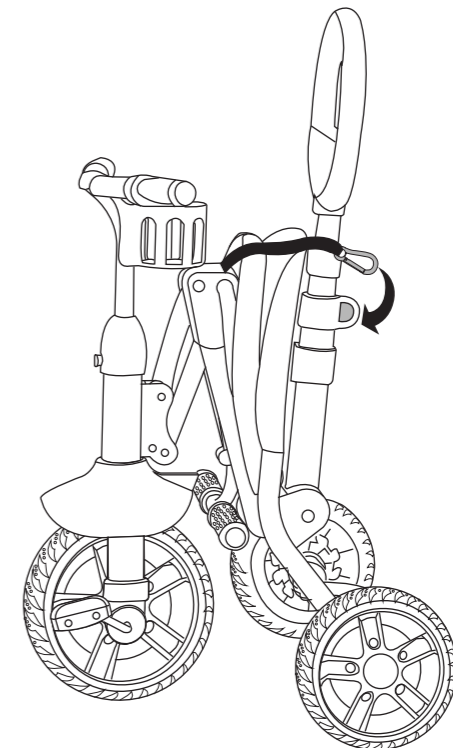

UNFOLDING

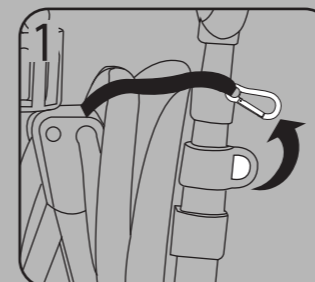

1 Unhook the strap from the parent handle.

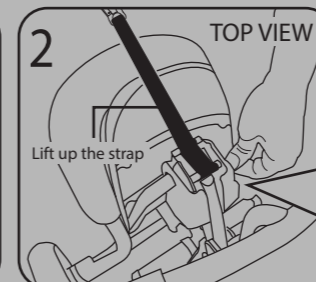

2 Pull out the pin with one hand. Then, with your other hand, lift up on the strap. Release the pin.

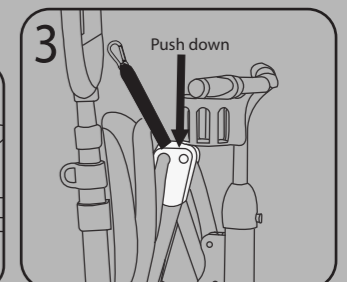

3 While still holding up the strap, push down on the frame. Then, push the pin back in. To finish unfolding, reverse steps 3-1 on page 10.

FOLDING

1. Push the button to lower the parent handle.

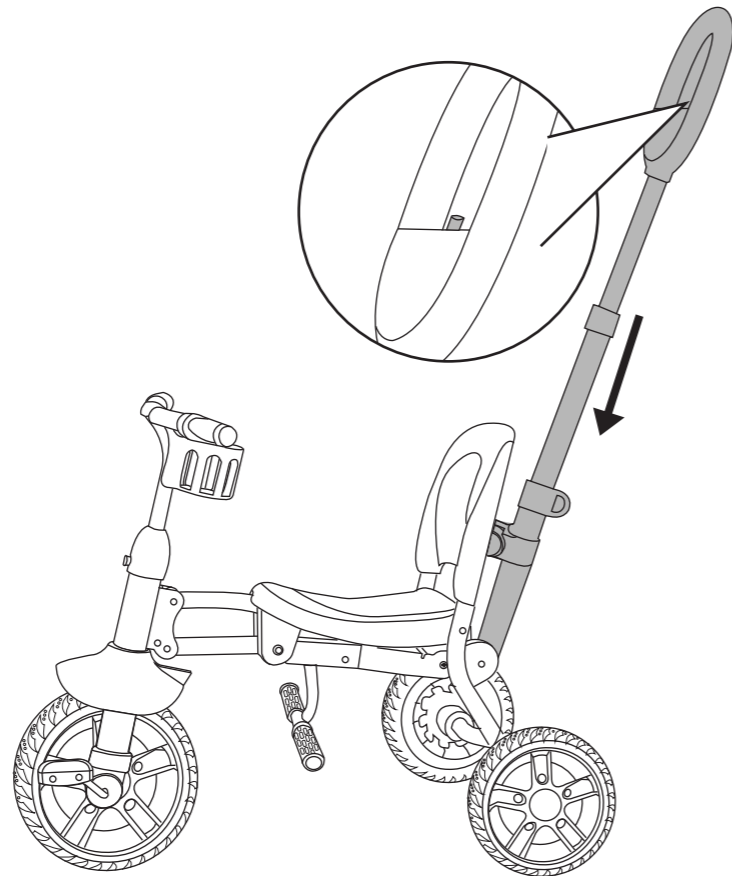

2. Adjust the parent handle by pressing the button on the bar and pushing the bar down.

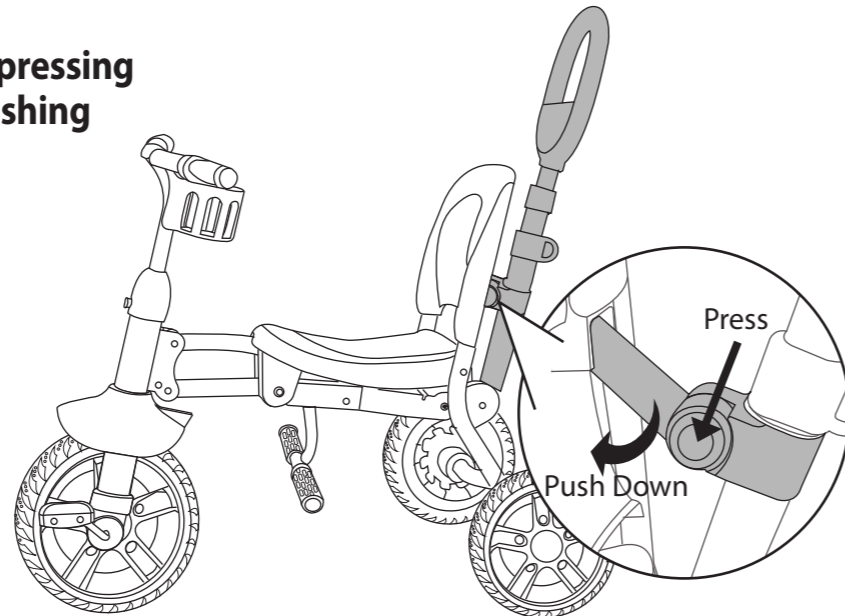

3. Lift the seat up. Then, press the button on the footrest to move backwards.

Note: For children who can't reach the pedals, press the button on the footrest to move to the forward position when unfolding.

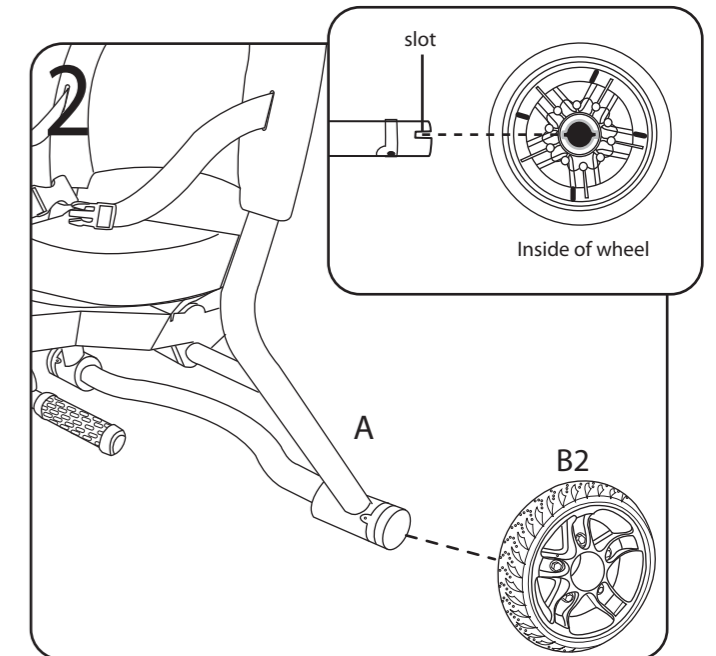
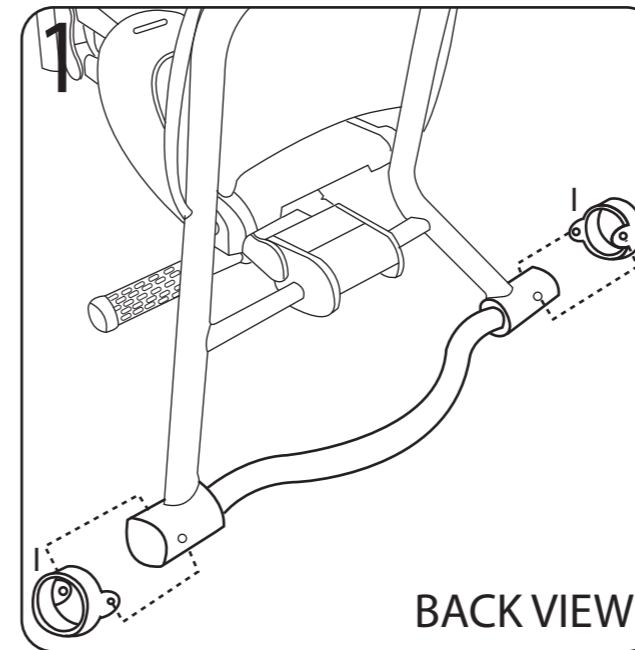
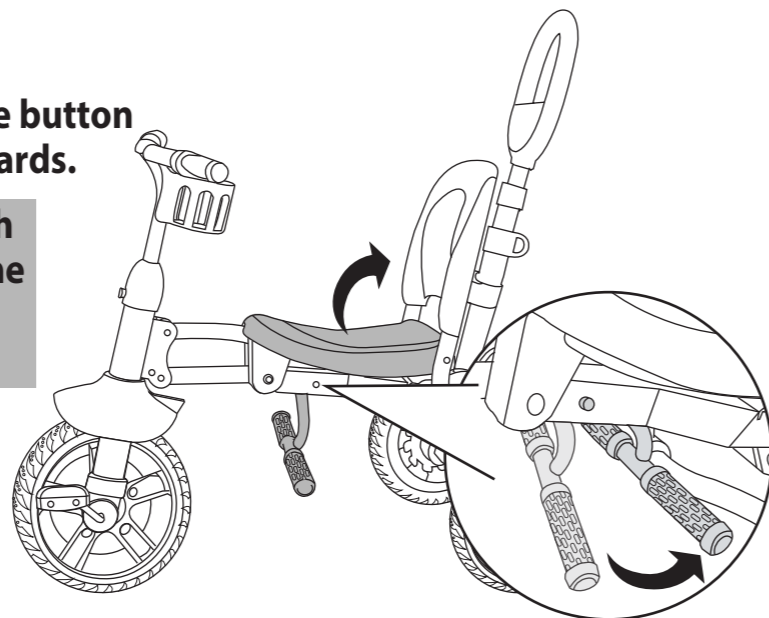

Align slots on wheel center with slots on axle (A).

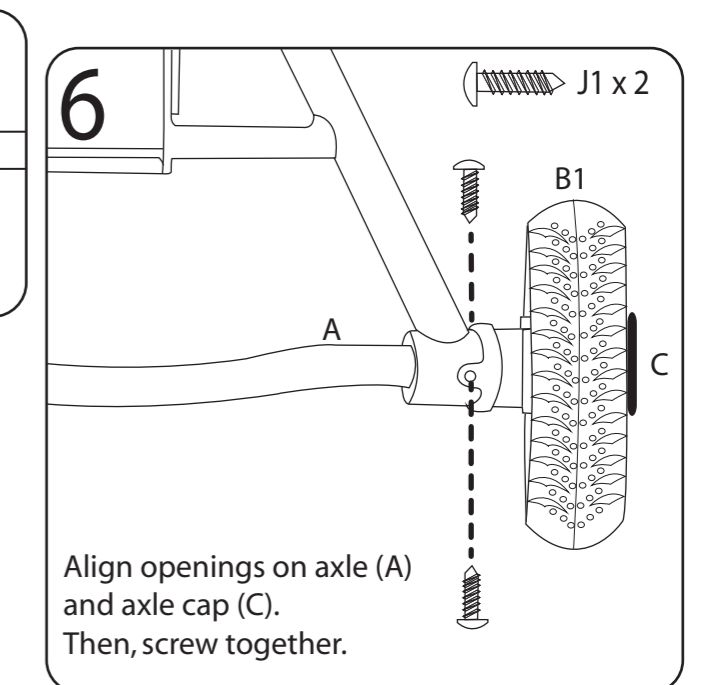
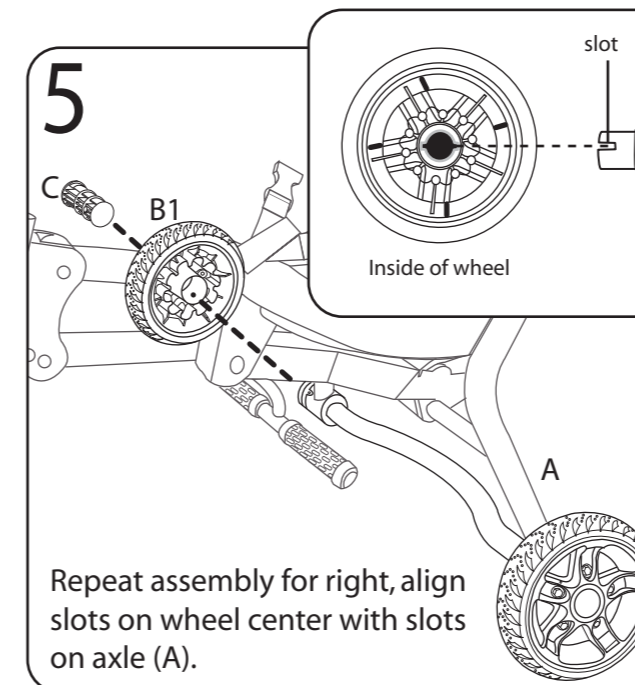
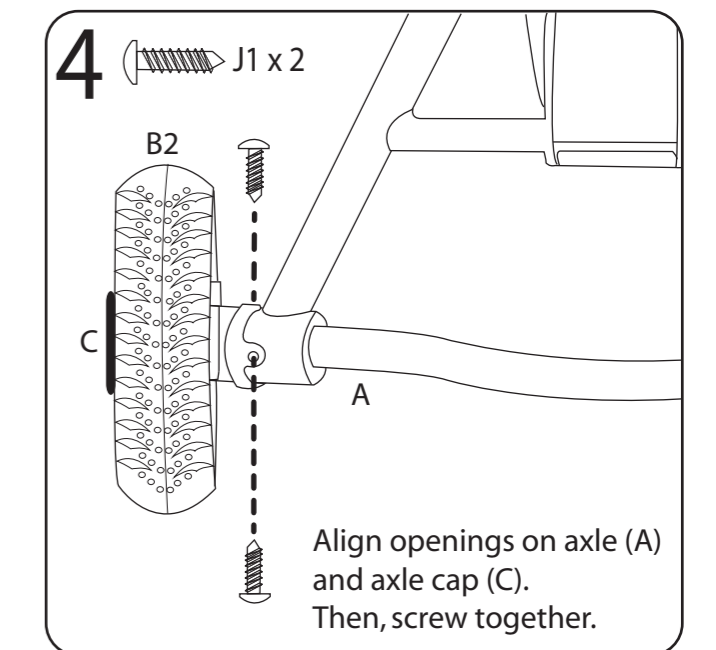
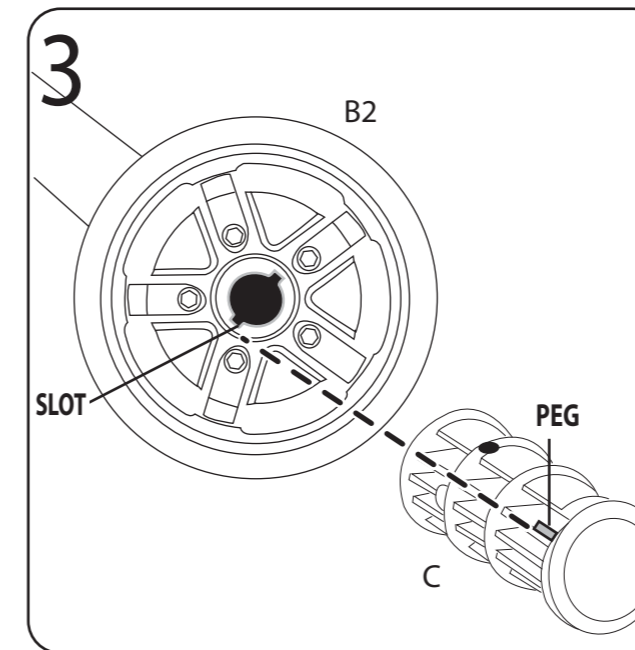

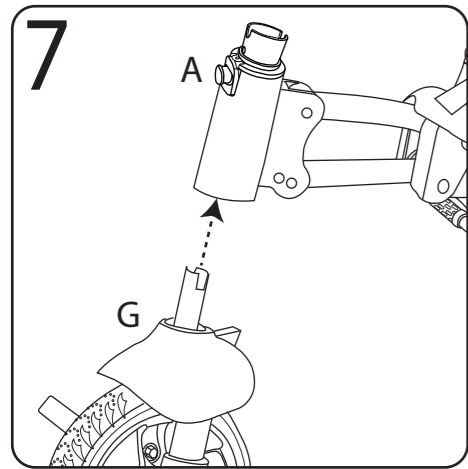

Press frame (A) and front wheel (G) together until it is in place.

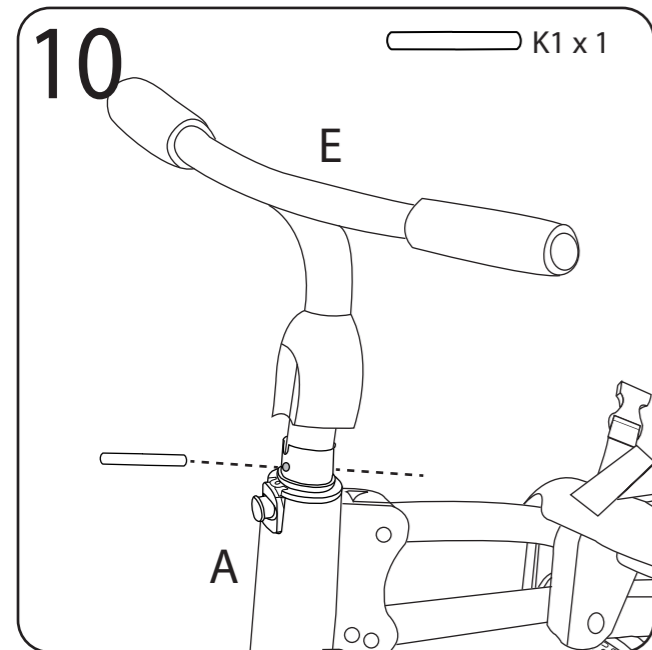
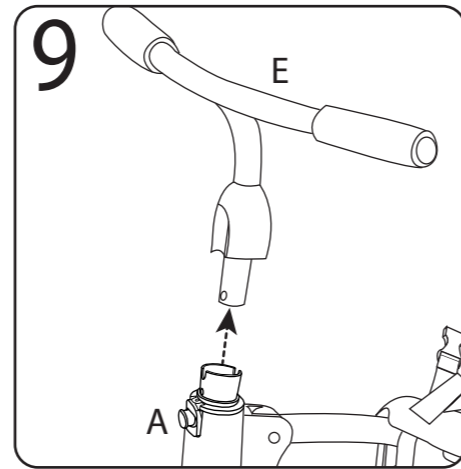
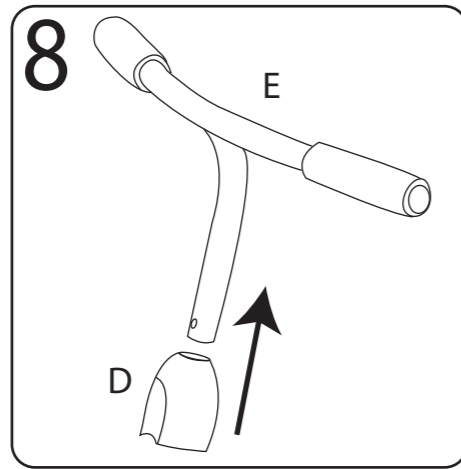

Insert the pin (K1), making sure the ends extend from both sides.

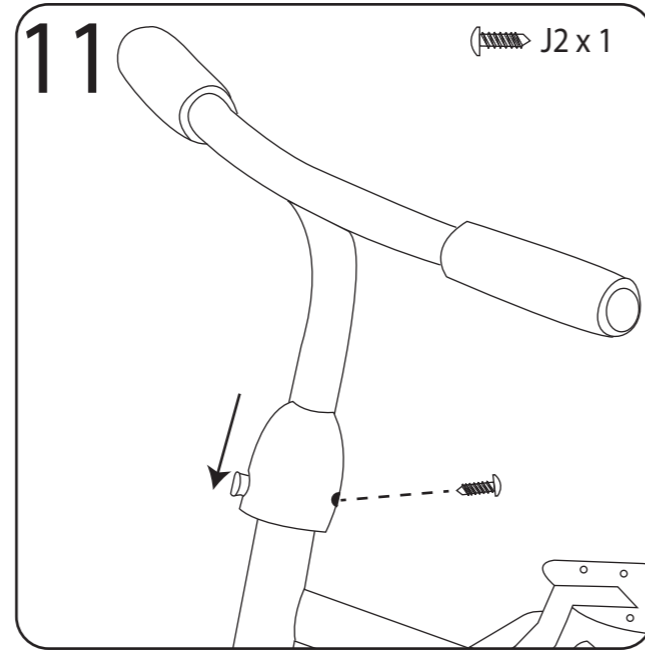

Push cap (D) down and secure with a screw (J2).

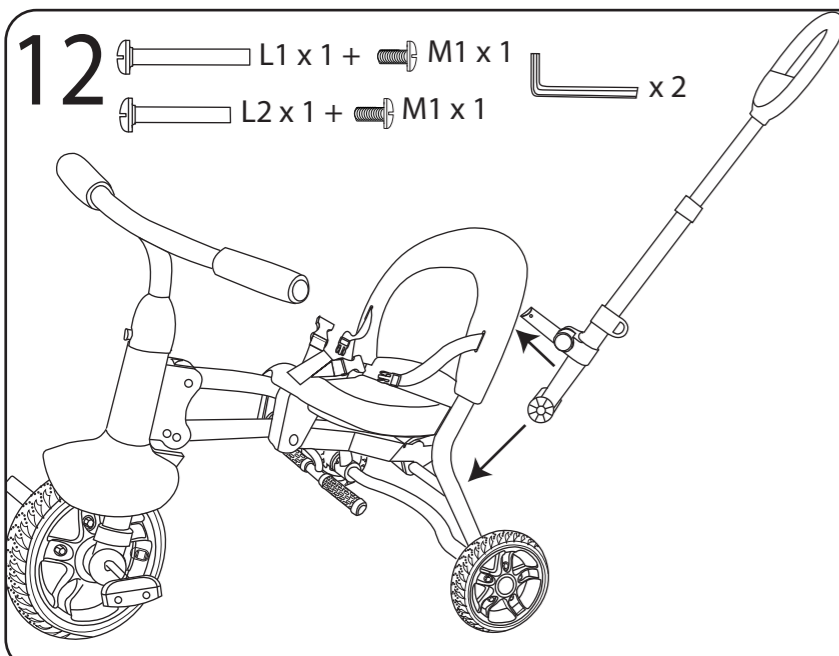

L1 x 1 + M1 x 1
L2 x 1 + M1 x 1

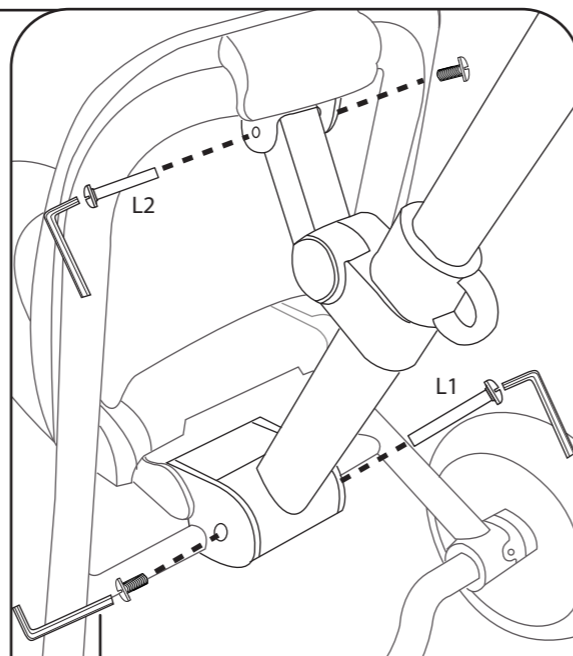

Use one Allen wrench to hold the screw (L1) in place and another to secure the other screw (M1).

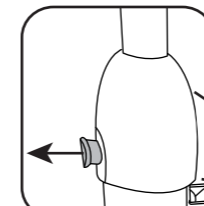

Pull out button to unlock the handlebar.

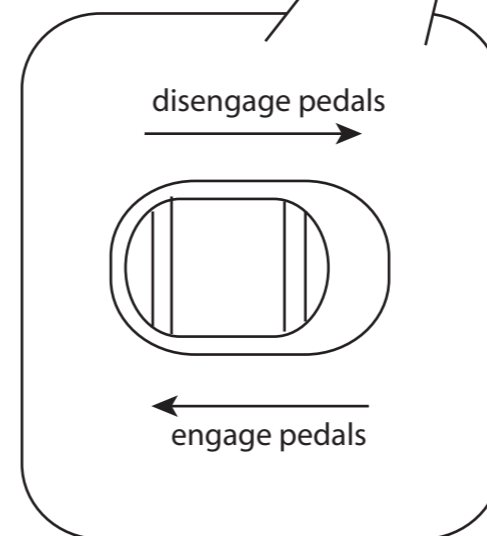

ENGAGE PEDALS FOR STAGE 3
Push in button. Then, slide to move. Rotate the front pedal if the button does not fully slide.

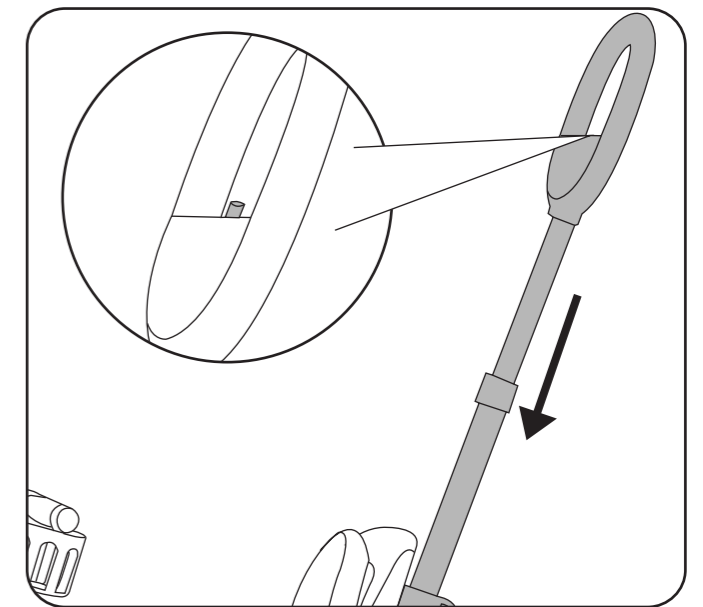

Push button to lower the parent handle.

STAGE 2 - LEARN

24+ Months

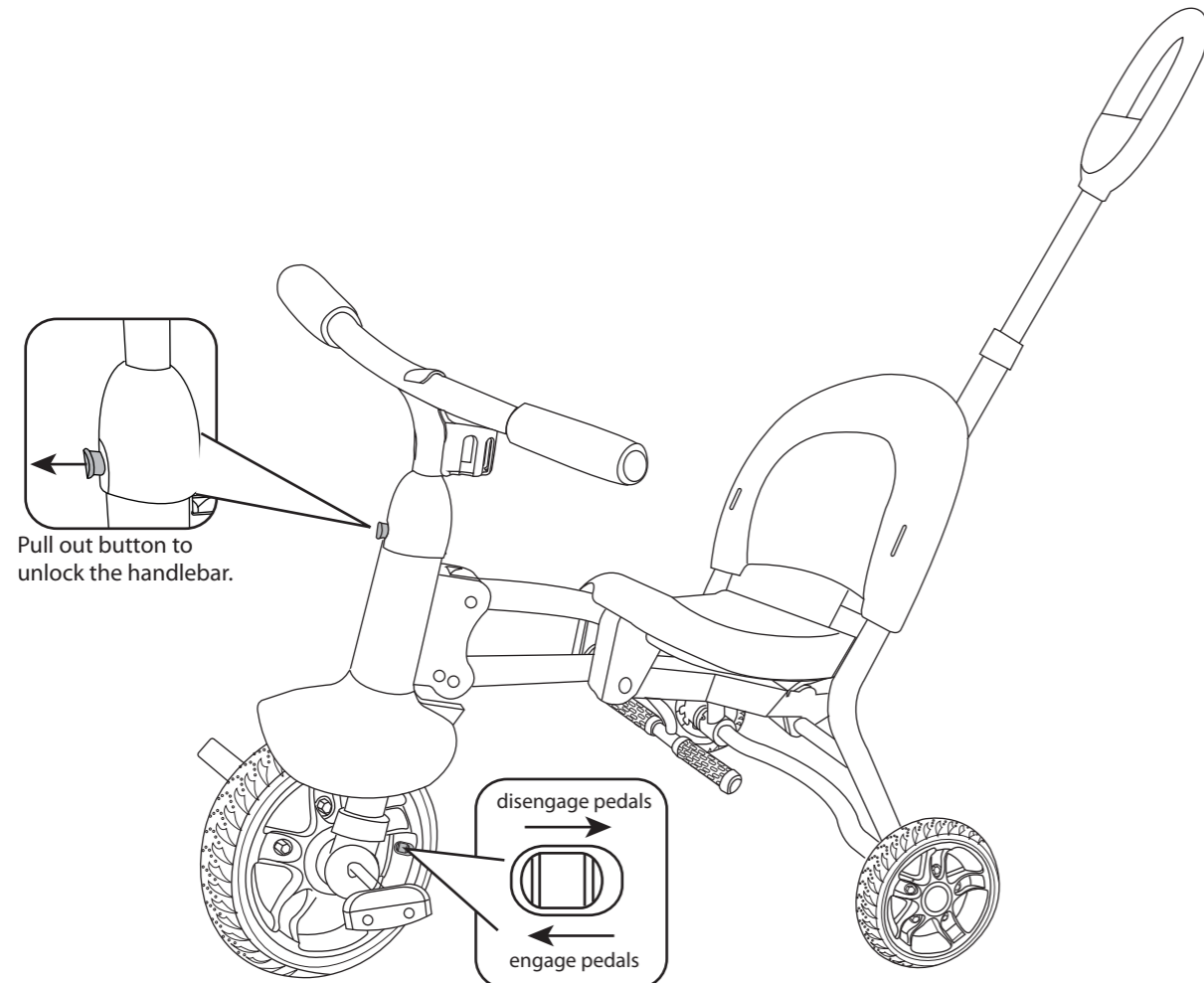

ENGAGE PEDALS FOR STAGE 2
Push in button. Then, slide to move. Rotate the front pedal if the button does not fully slide.

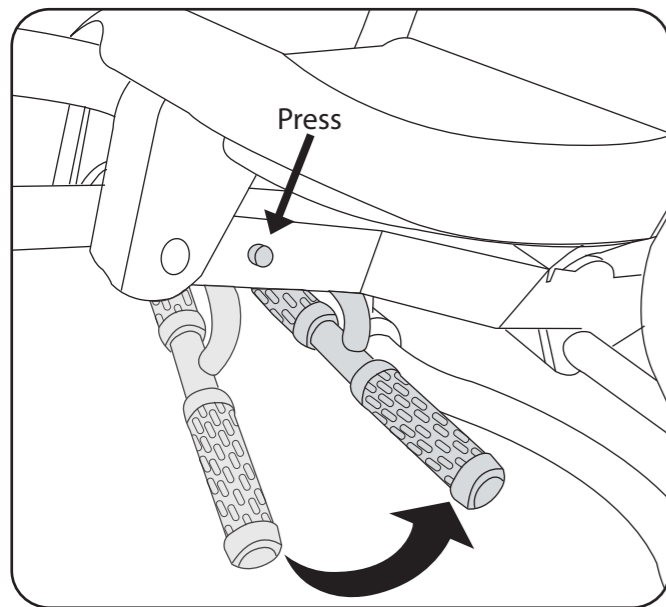

Press button and push footrest back.

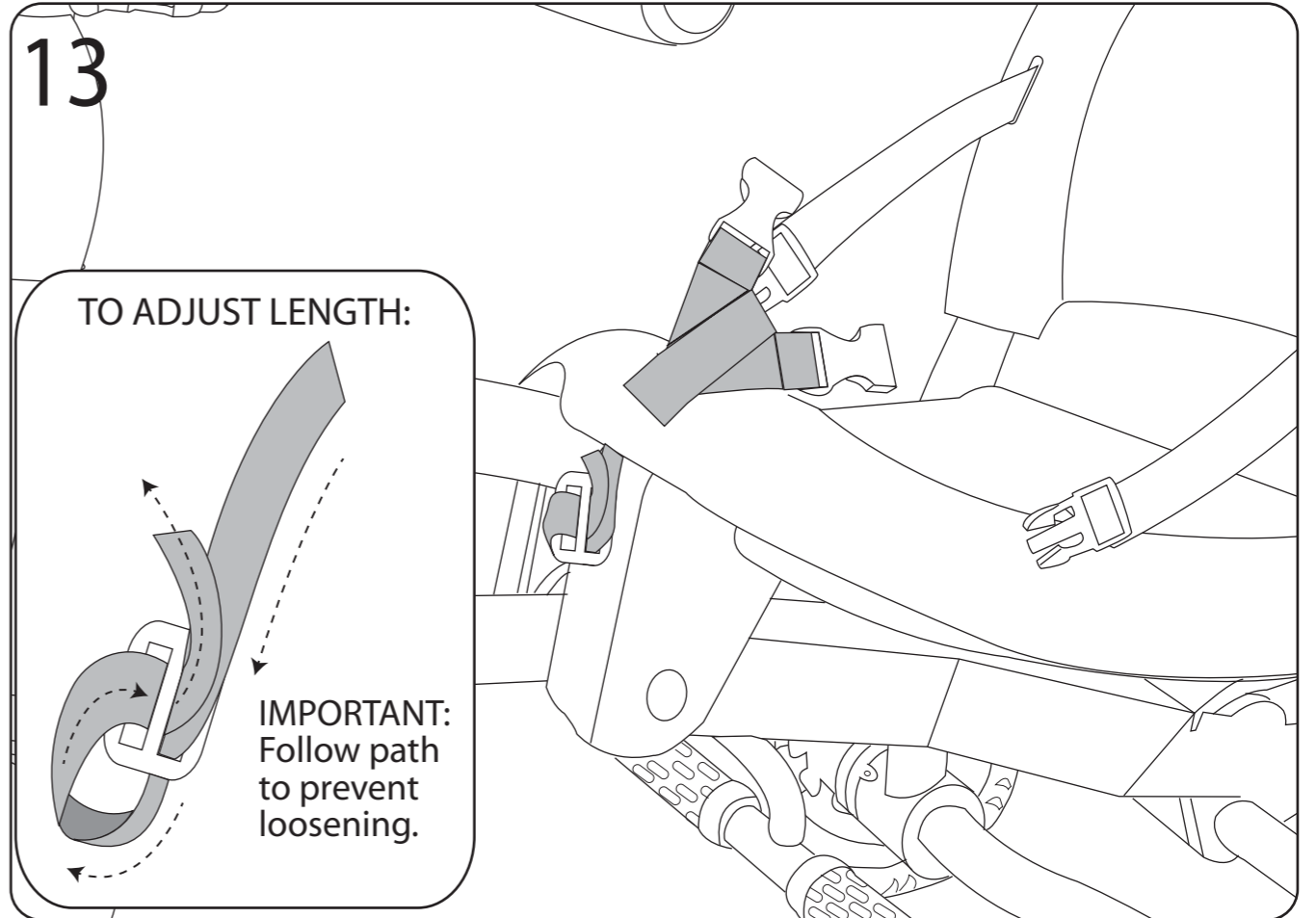
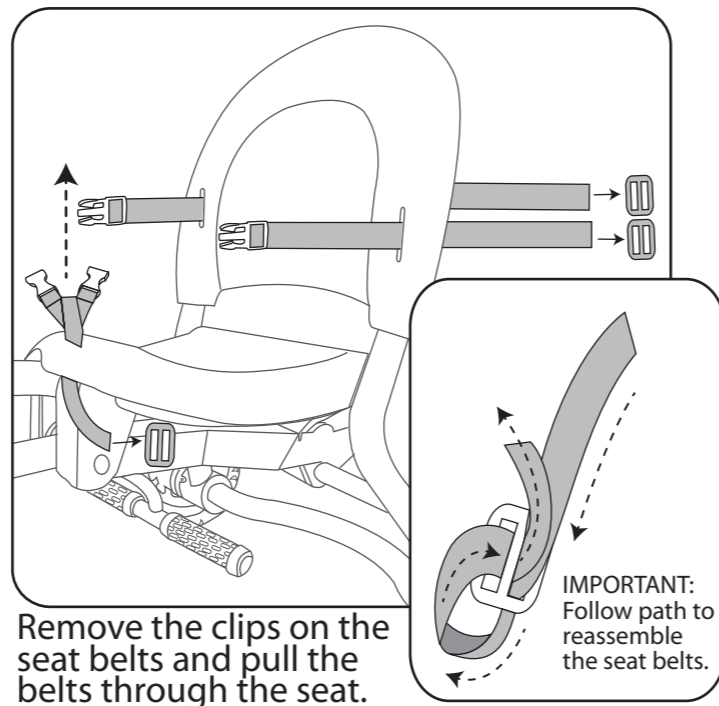

To adjust the center seat belt length, follow the path shown above. Pull seat belt tail through the clip until it is tight and secure.

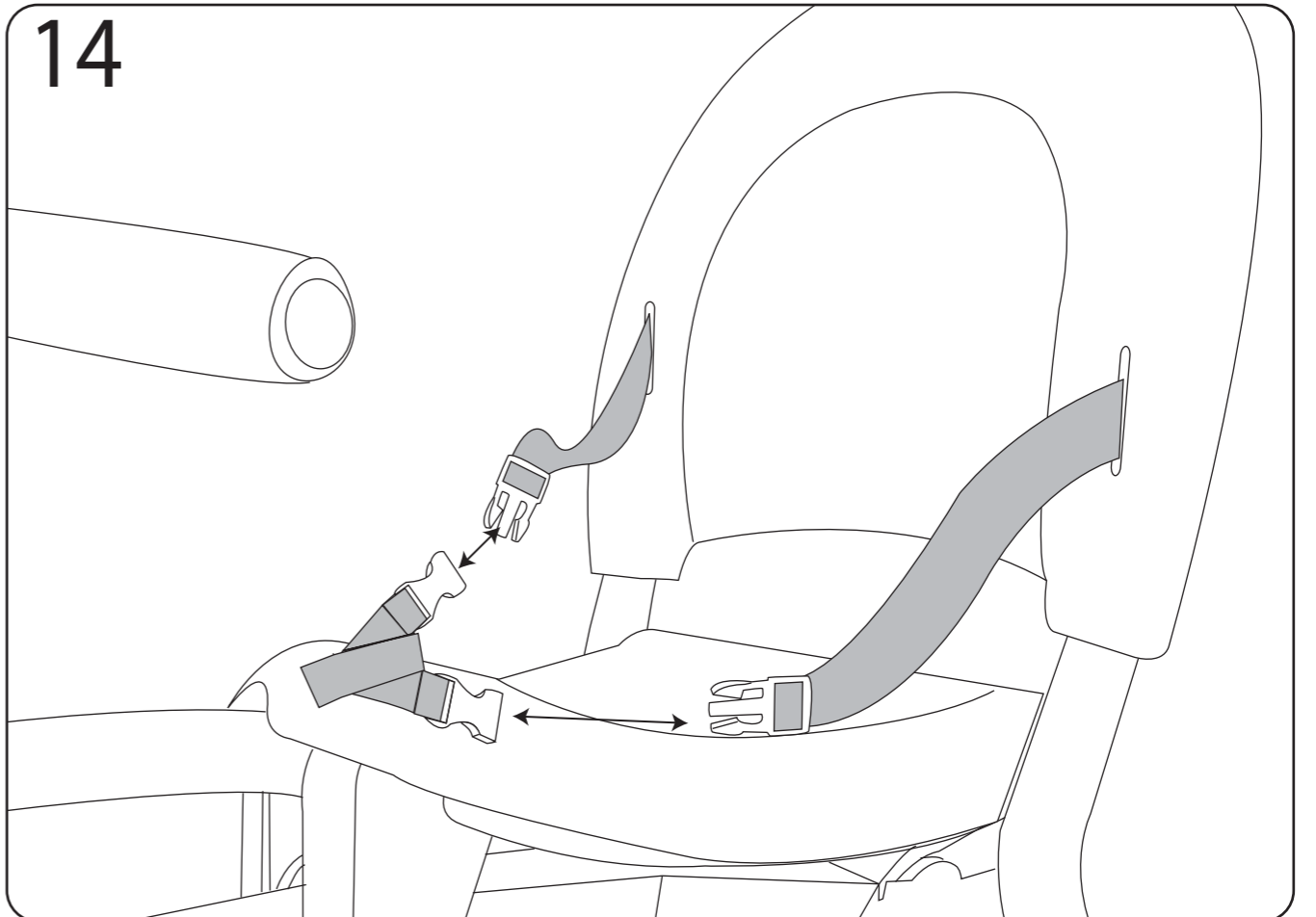

15

SNAP!

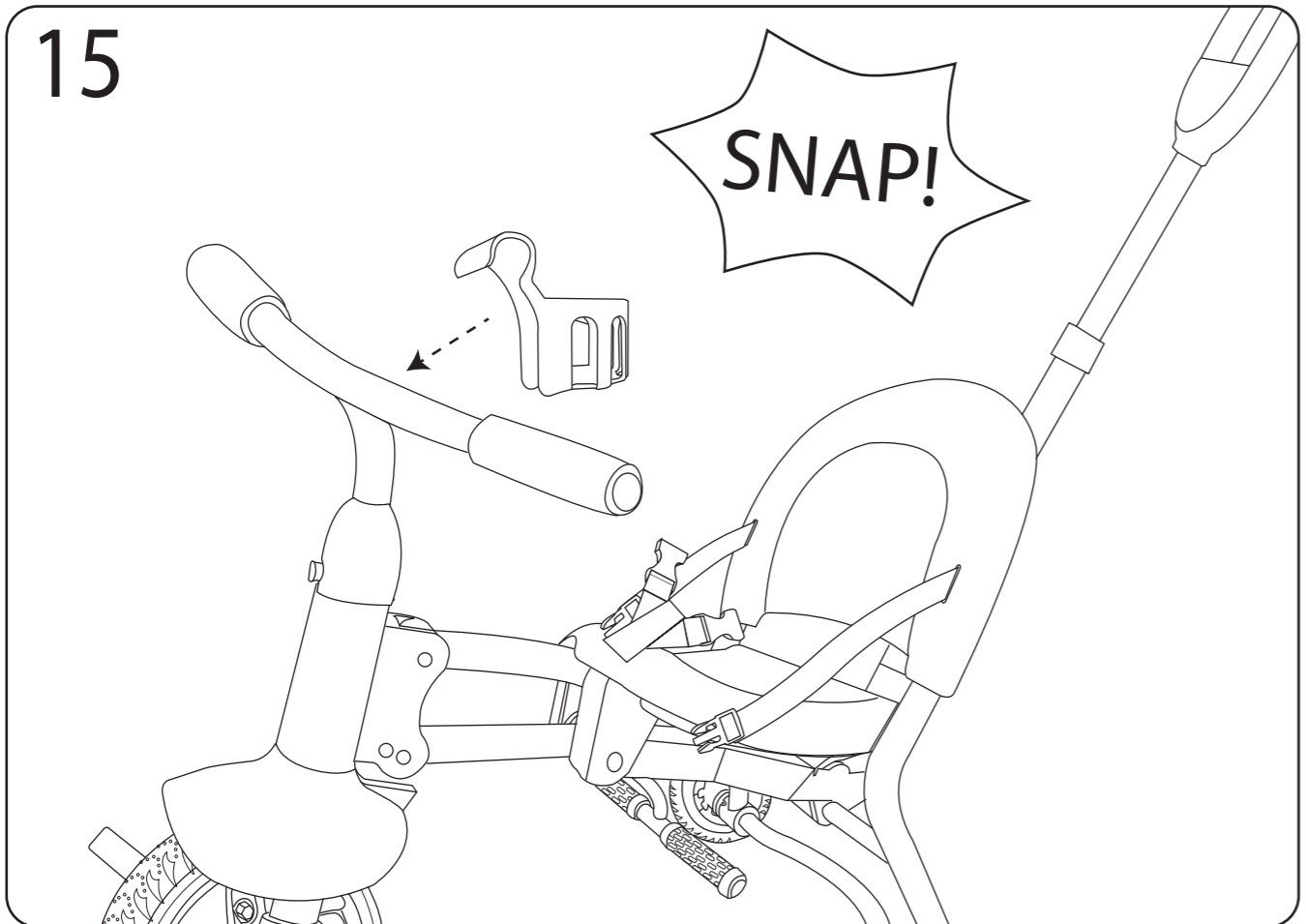

16

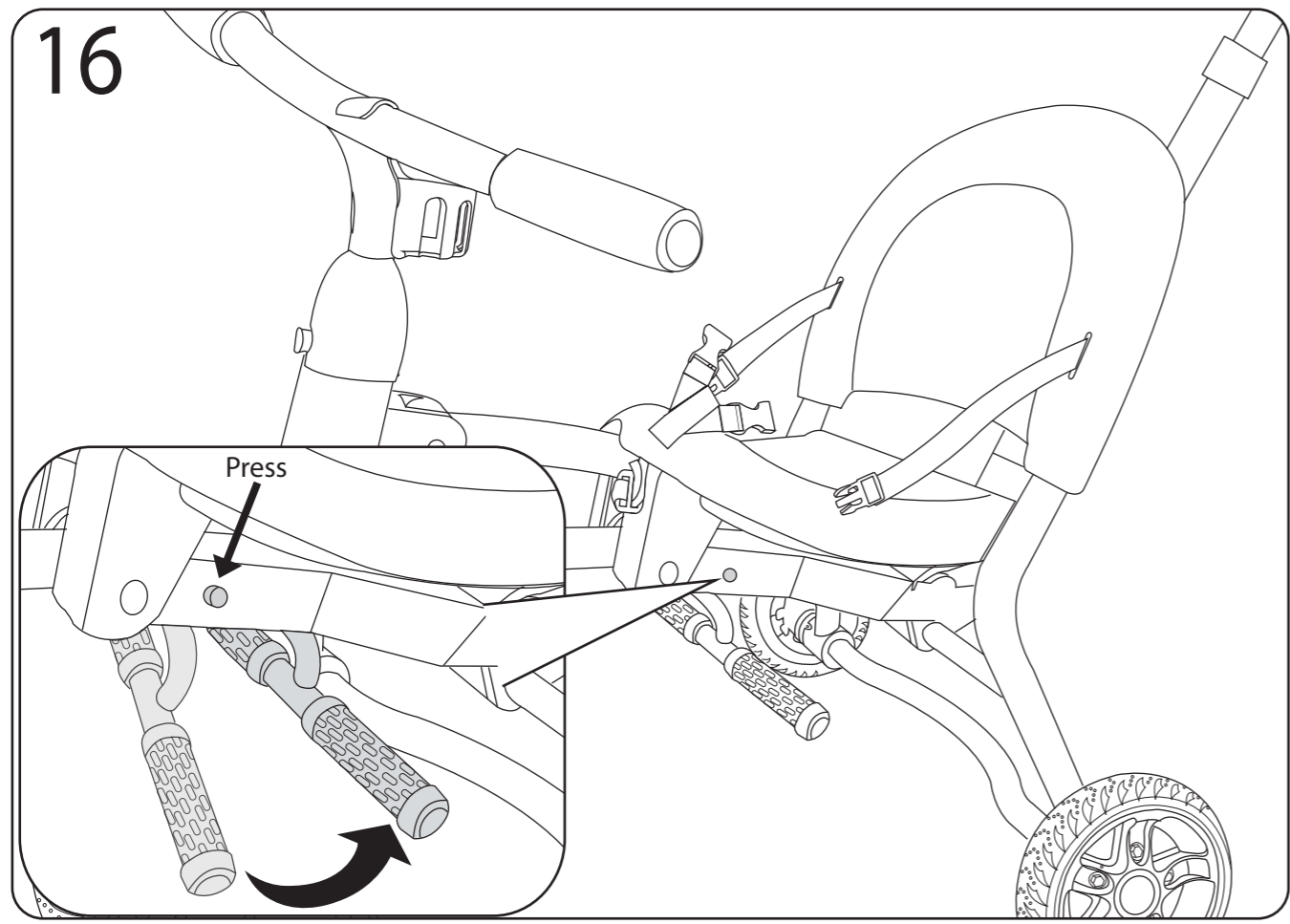

Press the button on the footrest to move backwards once your child is ready to pedal the trike.

STAGE 1 - PUSH

12+ Months

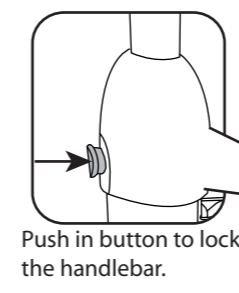

Push in button to lock the handlebar.

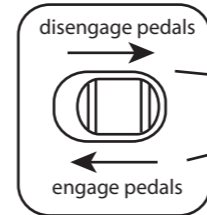

disengage pedals
engage pedals

DISENGAGE PEDALS FOR STAGE 1
Push in button. Then, slide to move. Rotate the front pedal if the button does not fully slide.

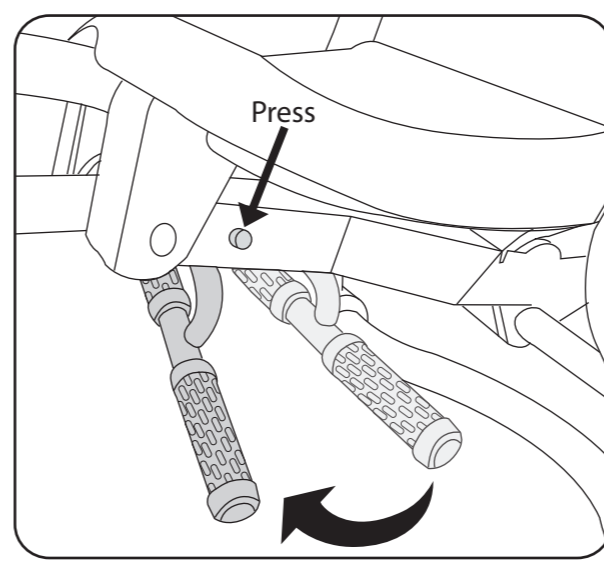

Press the button and move the footrest to the forward position.

