

LIMITED WARRANTY

The Little Tikes Company makes fun, high quality toys. We warrant to the original purchaser that this product is free of defects in materials or workmanship for one year * from the date of purchase (dated sales receipt is required for proof of purchase) and all other parts are free of defects in material or workmanship for 90 days*. At the sole election of The Little Tikes Company, the only remedies available under this warranty will be the replacement of the defective part or replacement of the product. This warranty is valid only if the product has been assembled and maintained per the instructions. This warranty does not cover abuse, accident, cosmetic issues such as fading or scratches from normal wear, or any other cause not arising from defects in material and workmanship.

*Trampoline Warranty:

We warrant to the original purchaser that the frame of this product is free of defects in materials or workmanship for 1 year from the date of purchase, and all other parts are free of defects in material or workmanship for 90 days from the date of purchase (dated sales receipt is required for proof of purchase).

U.S.A. and Canada: For warranty service or replacement part information, please visit our website at www.littletikes.com, call 1-800-321-0183 or write to: Consumer Service, The Little Tikes Company, 2180 Barlow Road, Hudson OH 44236, U.S.A. Some replacement parts may be available for purchase after warranty expires—contact us for details.

Outside U.S.A. and Canada: Contact place of purchase for warranty service. This warranty gives you specific legal rights, and you may also have other rights, which vary from country/state to country/ state. Some countries/states do not allow the exclusion or limitation of incidental or consequential damages, so the above limitation or exclusion may not apply to you.

PLEASE SAVE SALES RECEIPT FOR PROOF OF PURCHASE

Please keep this manual as it contains important information.



0722-1-C

© The Little Tikes Company, an MGA Entertainment company. LITTLE TIKES® is a trademark of Little Tikes in the U.S. and other countries. All logos, names, characters, likenesses, images, slogans, and packaging appearance are the property of Little Tikes.

Little Tikes Consumer Service

2180 Barlow Road
Hudson, Ohio 44236 U.S.A.
1-800-321-0183

MGA Entertainment UK Ltd.

50 Presley Way, Crownhill, Milton Keynes,
MK8 0ES, Bucks, UK
support@LittleTikesStore.co.uk
Tel: +0 800 521 558

Printed in China

MGA Entertainment (Netherlands) B.V.

Baronie 68-70, 2404 XG Alphen a/d Rijn
The Netherlands
Tel: +31 172 758 010
E-mail: klantenservice@mgae.com

Imported by MGA Entertainment Australia Pty Ltd

Suite 2.02, 32 Delhi Road
Macquarie Park NSW 2113
1 300 059 676



www.littletikes.com
www.littletikes.co.uk
www.littletikes.com.au

642265PC

little tikes

ENG

3-6
years

Easy Store™ 3 ft. Trampoline

ASSEMBLY, INSTALLATION, CARE, MAINTENANCE AND USER INSTRUCTIONS

Adult assembly and supervision required. Approx. assembly time: 30 min.



Thank you for choosing the Little Tikes® Easy Store™ 3 ft. Trampoline.
 We strive to provide a durable, easy-to-assemble toys that made to last, giving your child years of imaginative, engaging fun!

Really important information you should know!

Trampolines are great fun when used correctly. Most injuries are caused during the use of the trampoline, not because of their construction.

Read these instructions and warnings carefully and ensure you follow them at all times. Follow all assembly and maintenance instructions closely to ensure the equipment is safe to use and lasts as long as possible.

- You must thoroughly read this manual before assembling and using this trampoline.
- Clear a flat surface to lay out all the materials so everything is close at hand.
- The parts are listed - each part is identified with a letter in RED for easy reference.
- Illustrations are for reference only. Styles may vary from actual contents.
- **If you have any questions, we're here to help. Give our customer service team a call at 1-800-321-0183.**



WARNING: GENERAL

ADULT ASSEMBLY AND SUPERVISION REQUIRED

Read all instructions before using the trampoline. Warnings and instructions for the care, maintenance, and use of this trampoline are included to promote safe, enjoyable use of this equipment.

- Save this manual for future reference.
- Prior to assembly, this package contains small parts: hardware which is a choking hazard and may contain sharp points. Keep away from children until assembled.
- This trampoline is only suitable for domestic indoor use.
- The trampoline is not intended to be buried in the ground.
- Adult supervision required. Do not leave children unattended.
- Do not allow young children to use unless supervised by an adult.
- This product is intended for children 3 - 6 years of age and is not intended for use by children under 3 years of age due to their inability to use safely. Not recommended for children over 6 years of age.
- Limit one child at a time. Max. weight limit: 55 lbs. (25 kgs).
- The trampoline is designed for installation on flat surfaces with at least 2m clear space around the trampoline. Place the trampoline away from all objects such as walls, structures, furniture and other objects.
- Do not place on a hard surface (i.e. concrete or asphalt) serious injury may occur.
- Ensure there is 3m (9.8 ft) of clear area above the trampoline as measured from the trampoline surface. This area should be free of objects such as wires, ceiling fans, and other possible hazards.
- Ensure area under the bouncing surface is free of objects.
- Inspect the trampoline before each use. Make sure the frame padding is correctly and securely positioned. Replace any worn, defective, or missing parts.



WARNING: USAGE

- Do not attempt stunts including somersaults, serious injury may occur if stunts are attempted on this trampoline. Landing on the head or neck can cause serious injury, paralysis or death, even when landing in the middle of the bed.
- Children and unpracticed users must always jump under supervision by an experienced person, it is strongly recommended to use spotters at all times.
- Do not allow more than one person on the trampoline. Use by more than one person at the same time can result in serious injury.
- Only one user. Collision hazard.
- Do not eat while jumping.
- Use trampoline only with mature, knowledgeable supervision.

8

Last step....

Use the wrench (part M) to tighten the nuts on each folding safety bar.

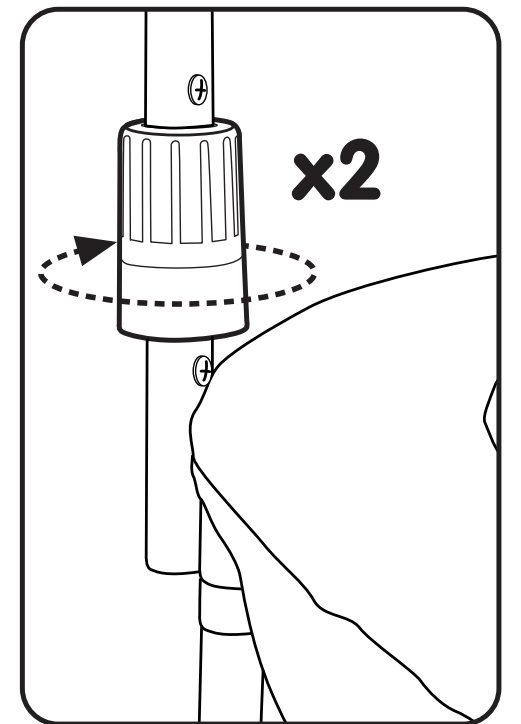
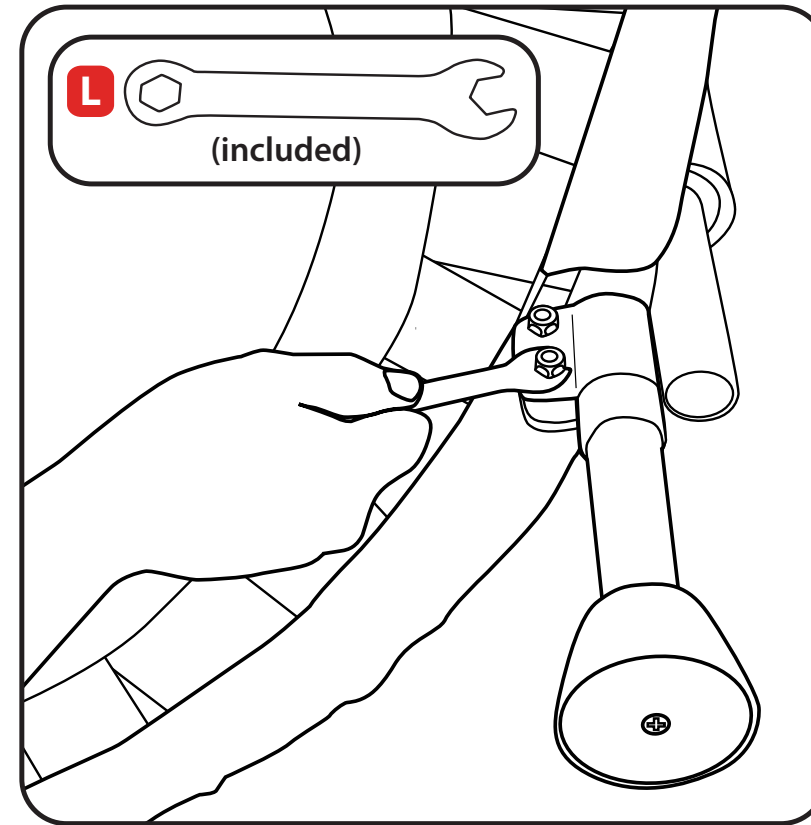

Twist clockwise to lock the safety bar in the upright position.

9

Folding and Storing...



WARNING:

Perform a complete inspection of the trampoline to make sure all parts are assembled and attached properly.

Read this entire manual and make sure all jumpers completely understand all of the safety rules printed in the manual and on the various warning signs.

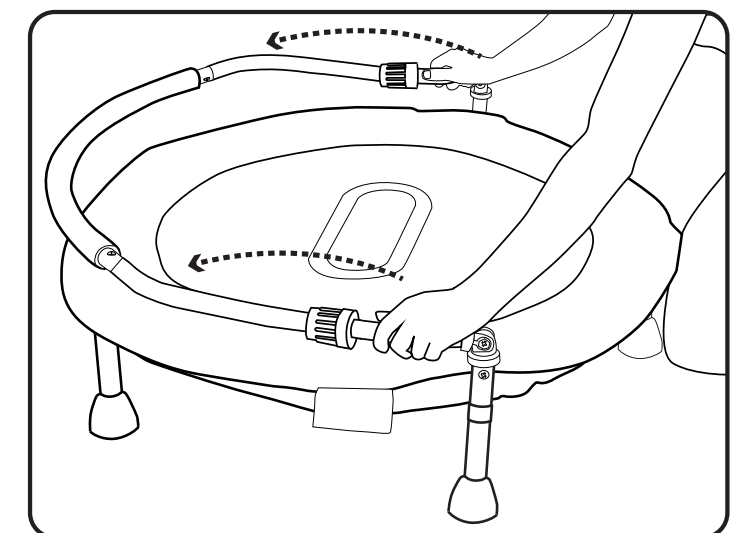
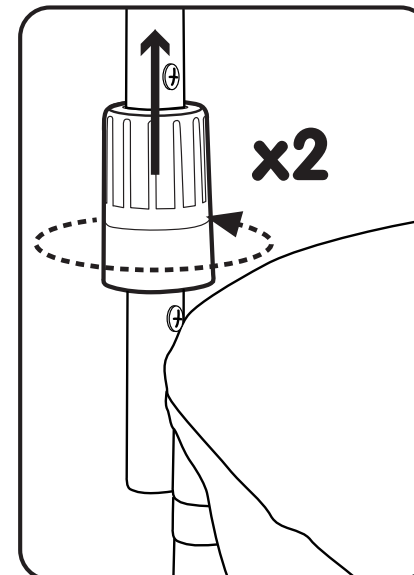

7 Finish with the safety bars!

Stand the trampoline on its legs. Place the curved safety bar with foam (part E) onto each end of the safety bars (part F).

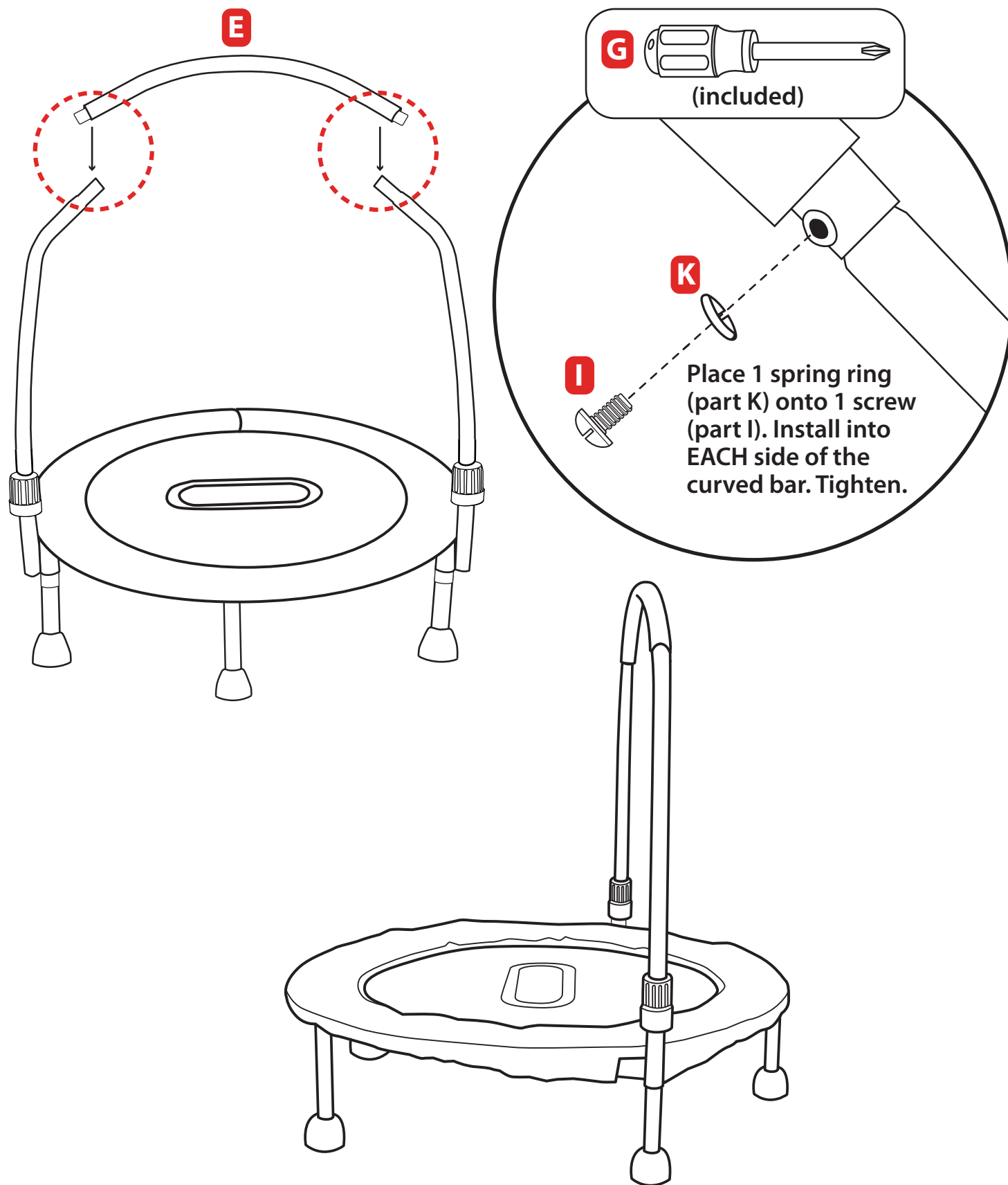

- Remove glasses, watches, jewelry and chains, ornaments, clasps and other sharp objects. Empty your pockets before starting to jump.
- Do not use the trampoline in the dark.
- Do not put any objects or toys on the trampoline.
- Do not use when wet.
- Jumpers must wear socks, gymnastic shoes, or be barefoot when using the trampoline. Please be aware that street shoes or tennis shoes should NOT be worn while using the trampoline.
- Jumpers should remove all sharp objects prior to using the trampoline. Any type of sharp or pointed objects should be kept off the trampoline mat at all times.
- To break a bounce, all you need to do is flex your knees sharply before they come in contact with the mat of the trampoline. This technique should be practiced while you are learning each of the basic bounces. The skill of braking should be used whenever you lose balance or control of your jump.
- Misuse and abuse of this trampoline is dangerous and can cause serious injury! Trampolines being a rebounding device, propel the performer to unaccustomed heights and into a variety of body movements.
- Always inspect the trampoline before each use for worn-out mat, loose or missing parts.

- Climbing on and off the trampoline: it is a dangerous practice to jump from the trampoline to the floor or ground when dismounting, or to jump onto the trampoline when mounting. Do not use the trampoline as a springboard to other objects.
- Avoid bouncing too high. Stay low until bounce control and repeated landing in the center of the trampoline can be accomplished. Control is more important than height.
- While keeping the head erect, focus eyes on the trampoline toward the perimeter. This will help control bounce.
- Keep objects away which could interfere with the performer. Maintain a clear area around the trampoline.
- Bounce only when the surface of the bed is dry. Wind or air movement should be calm and gentle. The trampoline must not be used in gusty or severe winds.
- Bounce in the center of the bed.
- Secure the trampoline against unauthorized use.
- Limit the time of continuous usage (make regular stops).
- Modifications made by the consumer to the original trampoline (e.g. the adding of an accessory) shall be carried out according to the instructions of the manufacturer.
- Make sure that the hook-and-loop fasteners are closed correctly during use of trampoline.

Care, maintenance and use instructions

MUST be read carefully before using the trampoline!

This trampoline was designed and manufactured with quality materials and craftsmanship. If proper care and maintenance is provided, it will provide all jumpers with years of exercise, fun, and enjoyment as well as reduce the risk of injury. Please follow the guidelines listed below:

- Please make sure that only one person at any one time uses the trampoline.
- In order to prevent the trampoline mat from getting cut or damaged please do not allow any pets onto the mat.
- Always inspect the trampoline before each use for worn, abused or missing parts. A number of conditions could arise that may increase your chances of getting injured.

Please be aware of:

- Punctures, holes, or tears in the trampoline mat
- Sagging trampoline mat
- Loose stitching or any kind of deterioration of the mat
- Bent or broken frame parts, such as legs or poles
- Damaged, missing, or insecurely attached frame pad
- Protrusions of any types (especially sharp) on the frame, springs, or mat.

IF YOU FIND ANY OF THE PREVIOUS CONDITIONS, OR ANYTHING ELSE THAT YOU FEEL COULD CAUSE HARM TO ANY USER, THE TRAMPOLINE SHOULD BE DISASSEMBLED OR SECURED FROM USE UNTIL THE CONDITION(S) HAS BEEN RESOLVED.

Carry out checks and maintenance of the main parts (frame, suspension system, bed, pads and enclosure) at regular intervals. If these checks are not carried out the trampoline could become dangerous.

It is of particular importance that these be followed at the beginning of each season, as well as at regular intervals during the usage season.

- Check all nuts and bolts for tightness and tighten when required.
- Check all coverings for bolts and sharp edges and replace when required.
- Check for evidence of wear or deterioration and replace if needed in accordance with these instructions.







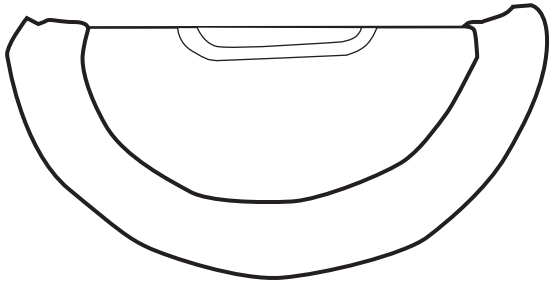

A Few Things Before You Start!

BEFORE you begin assembly, make sure you have all the parts listed below.

! Some packages of hardware may have extra pieces.

! Questions? We're here to help.

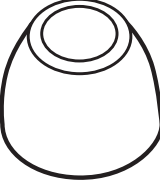
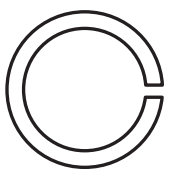
Little Tikes customer service team at 1-800-321-0183.

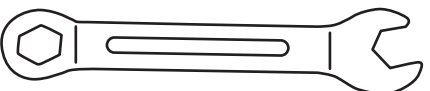
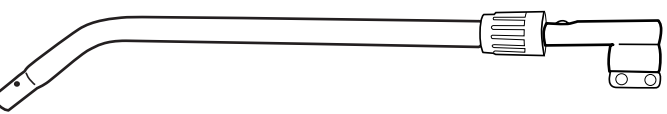
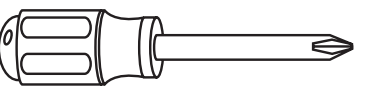
<p>A Trampoline Mat & Frame (1)</p> 	<p>H 1 1/2" Bolts (2)</p> 
<p>B Frame Legs (3)</p> 	<p>I 1/2" Screws (2)</p> 
<p>C Folding Handle Legs (2)</p> 	<p>J Cap Nuts (2)</p> 
<p>D Leg Stops (5)</p> 	<p>K Spring Ring (4)</p> 
<p>E Curved Safety Bar with Foam (1)</p> 	<p>L Wrench (1)</p> 
<p>F Safety Bars (2)</p> 	
<p>G Screwdriver (1)</p> 	

6 Folding handle legs...match it up!

Install the safety bars (part F) onto the trampoline frame in the locations with the color dots.

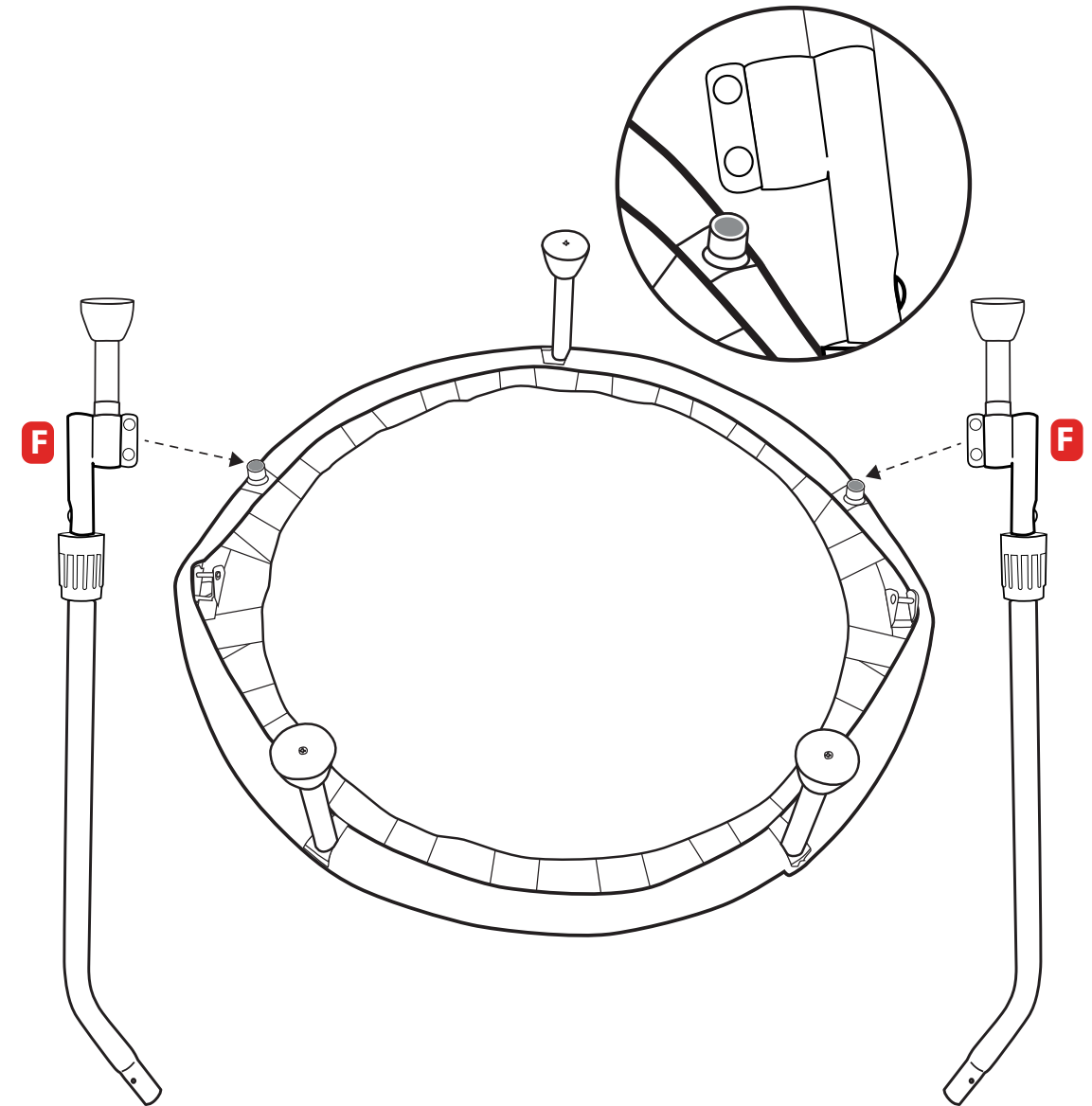

Once the safety bar is in the correct position on the trampoline, turn the folding handle leg to tighten.

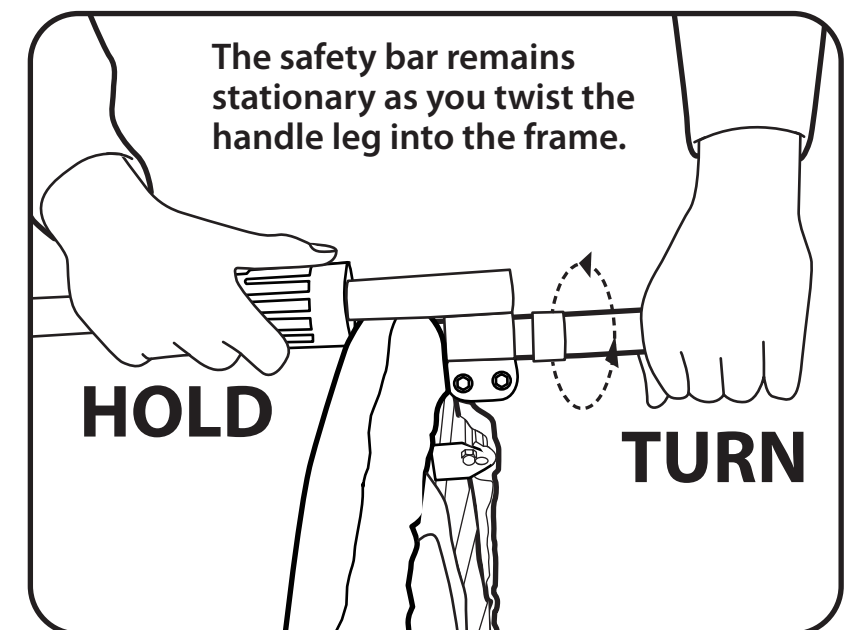

5 Easy peasy...frame legs go first

Start with the 3 FRAME LEGS (part B). These are the legs with NO METAL LIP. Thread them onto the trampoline frame in the locations with NO COLOR DOTS.

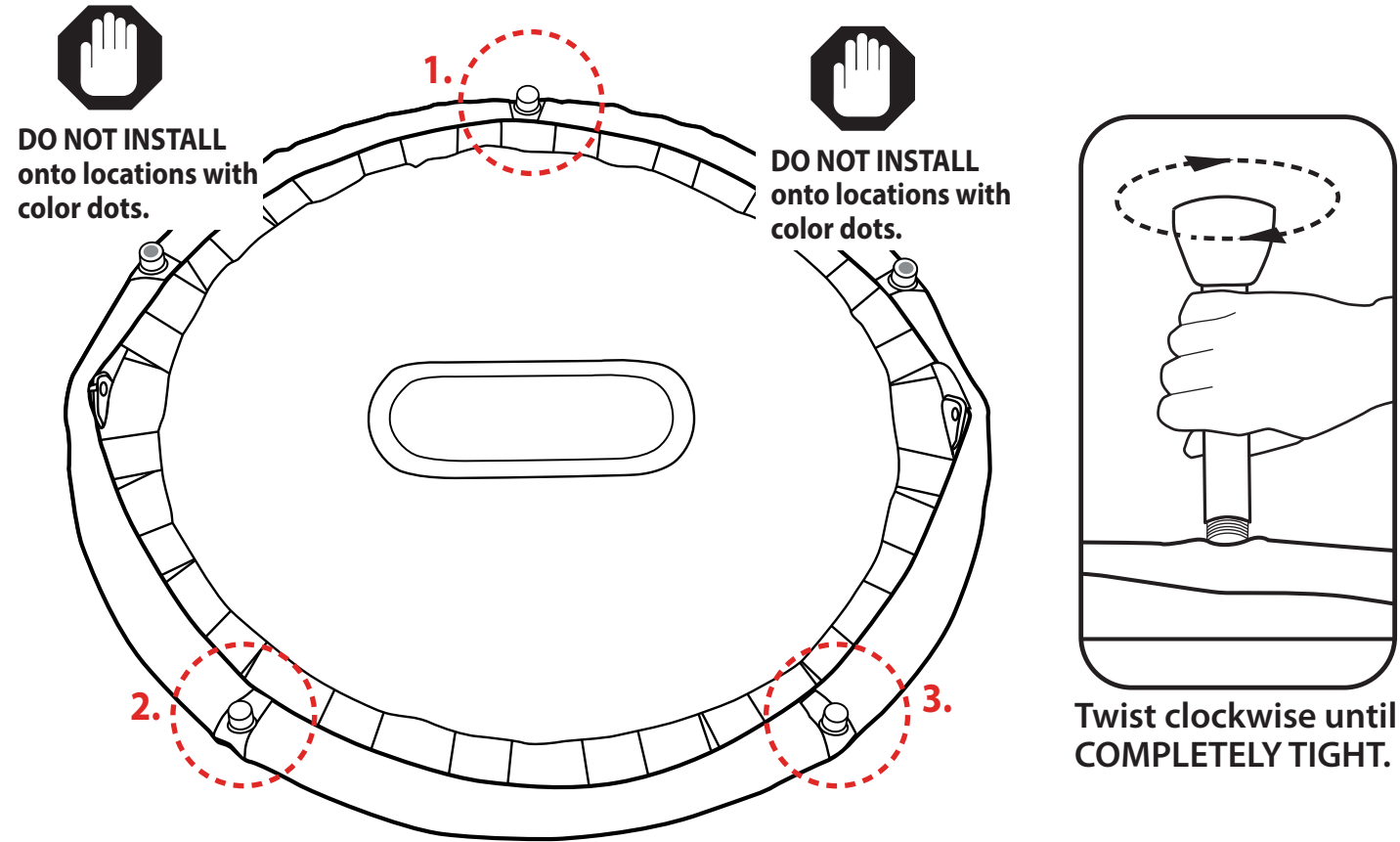

6 Folding handle legs...match it up!

Insert a folding handle leg (part C) into the end of EACH safety bar.

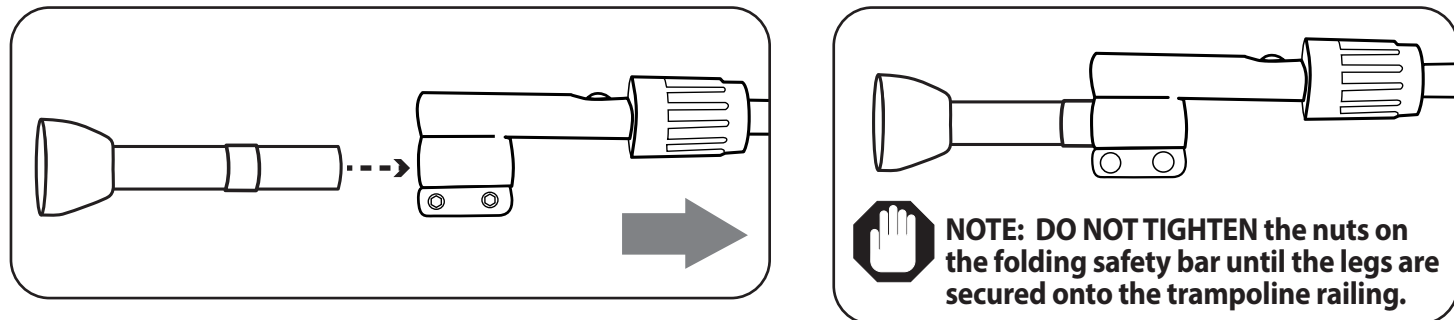

1 Let's get started...opening the trampoline

- Always use 2 or more strong adults to perform this step and keep your face away from the rails. Failure to do so may allow the rails to spring back into the folded position and cause harm.
- Keep fingers away from the end of the rails near the hinged area when unfolding the trampoline.

1. Gather a nut (J), bolt (H), and spring ring (K) and place next to each hinge on the floor PRIOR to unfolding the trampoline.
2. Lay the folded trampoline on the floor, in its still folded position.
3. Hold one side down firmly.
4. Using steady pressure, with hands open and fingers extended, pull on the other side to open.
5. Open the trampoline fully, until hinges snap into place.

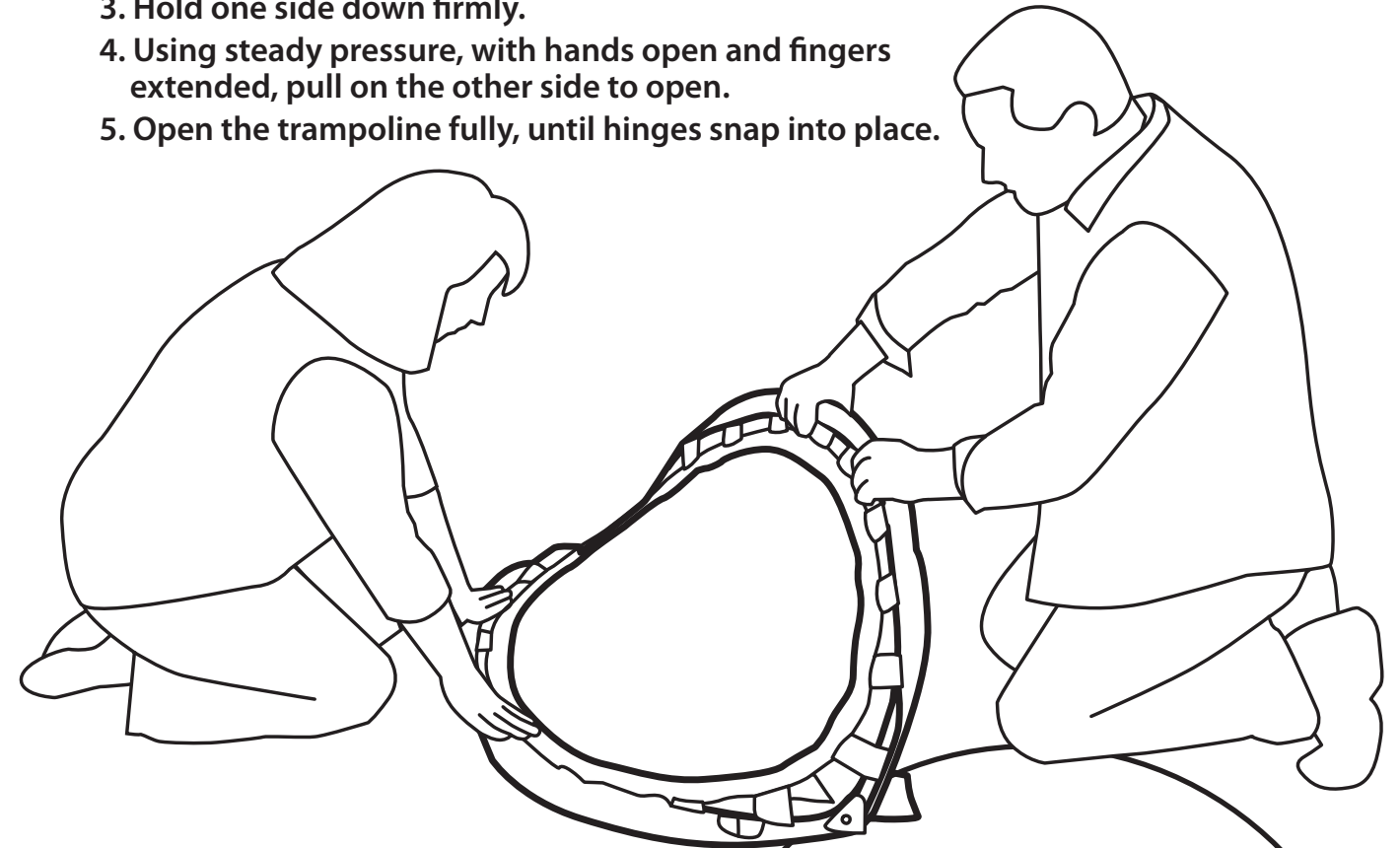

WARNING:
Adult assembly required.

Impact hazard exists until hardware is installed. Keep face and arms away until hardware is installed. Do NOT leave trampoline unfolded without completely installing the bolts according to the instructions.

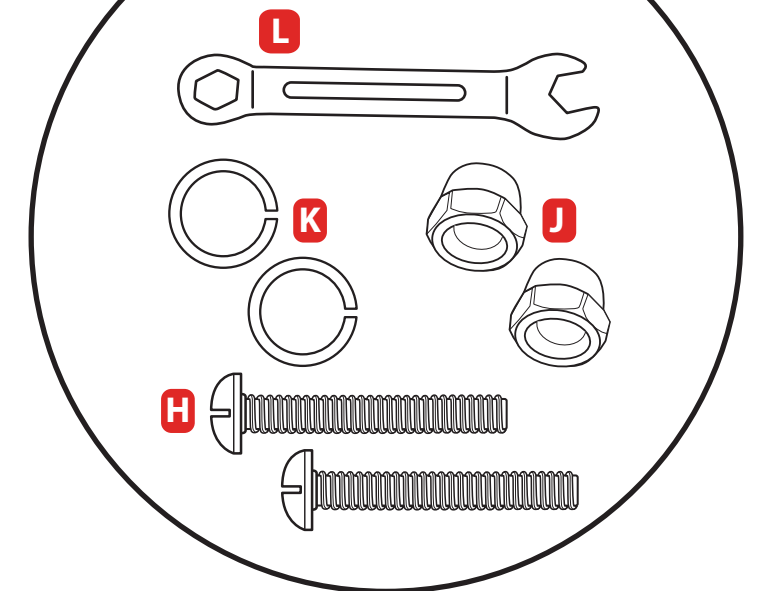

2 Make sure it's hinged...

Insert 1 1/2" bolt (part H) through the hinge. Place (1) spring ring (part K) onto the end of the bolt.

Place (1) cap nut (part J) onto the end of each bolt.

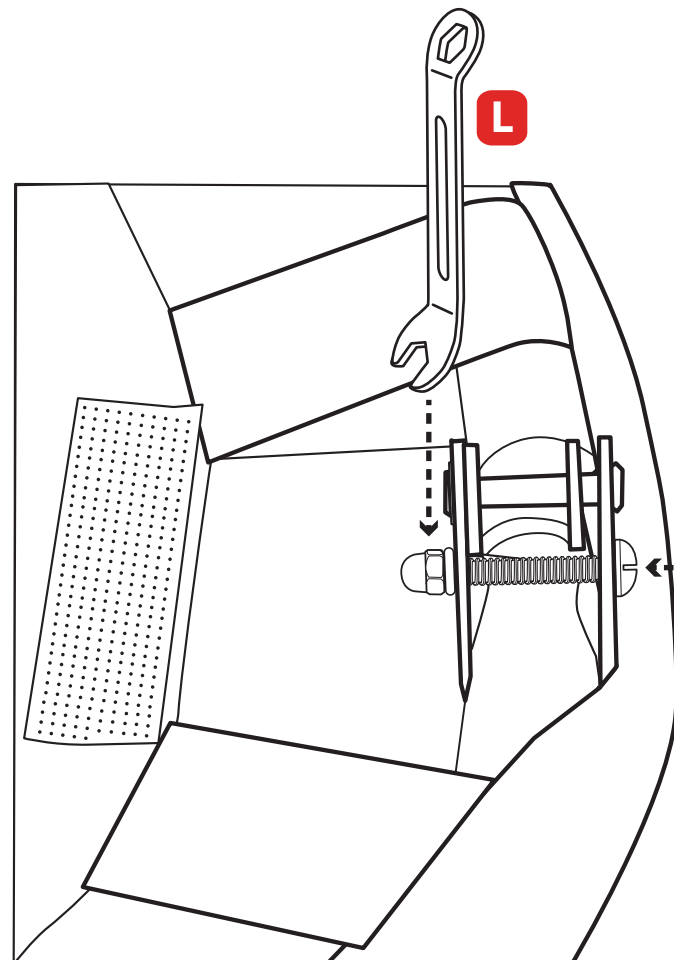
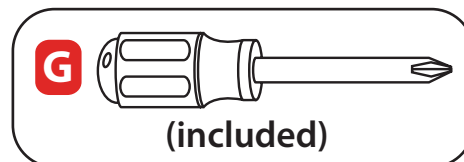
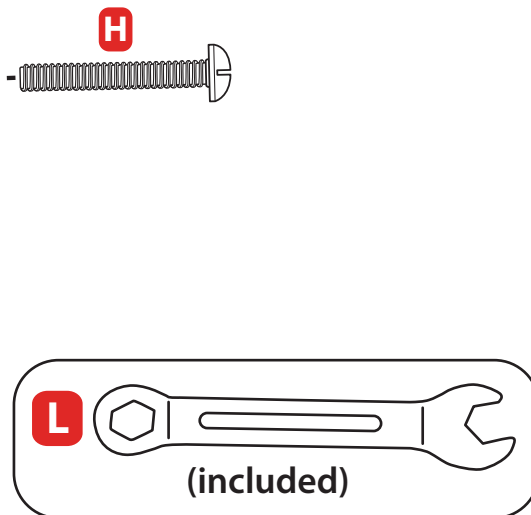
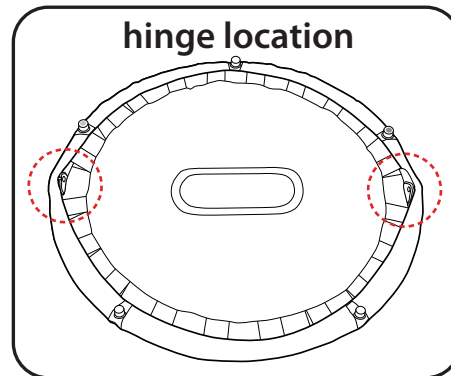
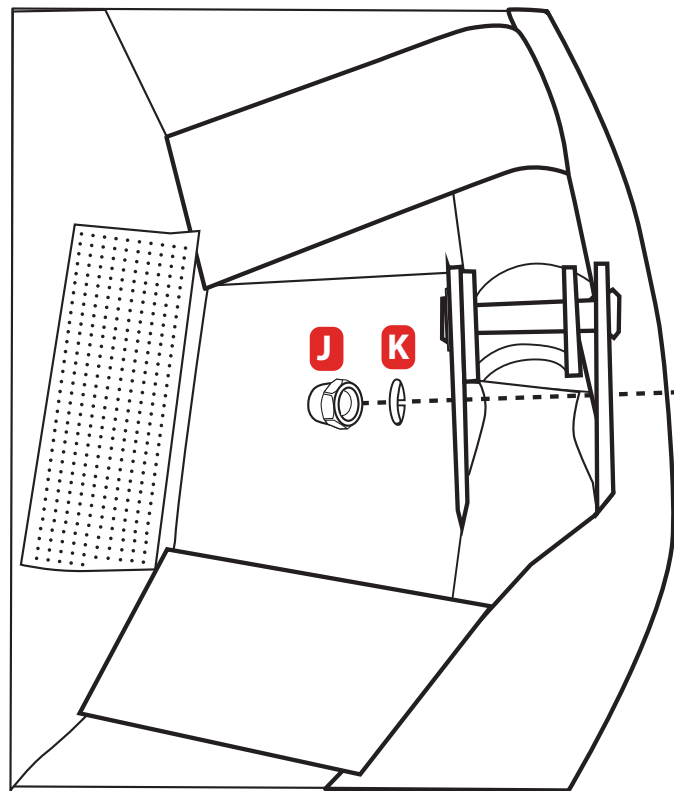

Hold the cap nut using the wrench. Tighten using a Philips screwdriver. Repeat these steps to secure hinge on the opposite side.

3 Uncap and Pull...

Remove all protective end caps from screw threads and discard. Keep out of reach of children.

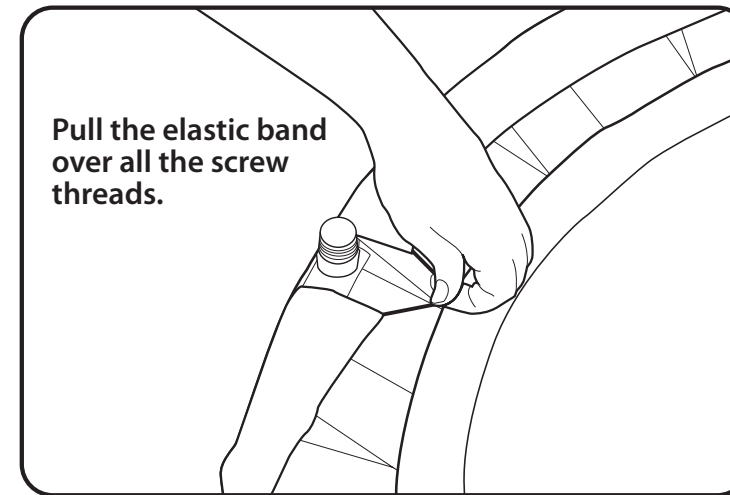
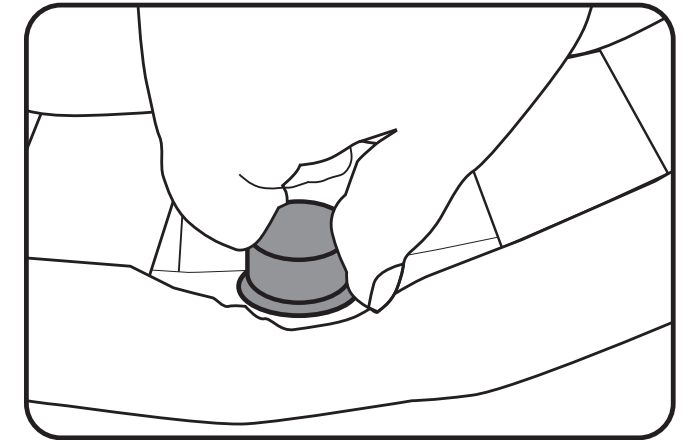

Pull the elastic band over all the screw threads.

4 Get a Leg Up!

Attach a leg stop (part D) to each of the (3) frame legs (part B).

Attach a leg stop (part D) to each of the (2) folding handle legs (part C).

