

matatalab **EDU**

# Building Manual

Creator Kit for VinciBot

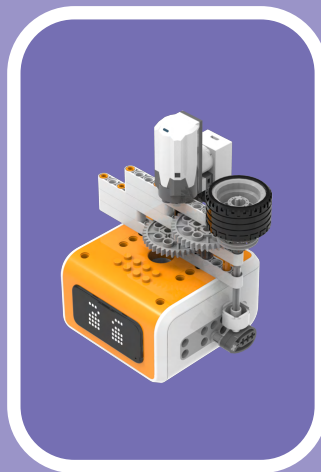

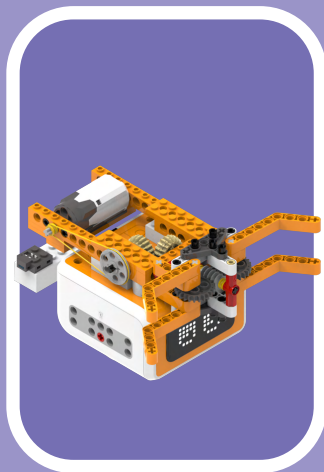
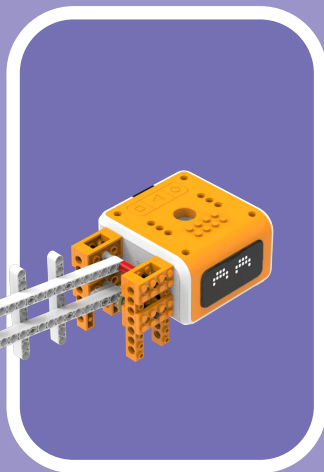
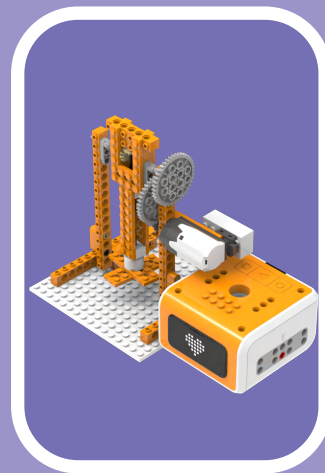

# Contents

Case 1 VinciBot is a Dancer

Case 2 Big Pendulum Ride

Case 3 Mechanical Claw

Case 4 Induction Door

Case 5 Smart Fan

Case 6 Gyroscope Transmitter

<https://en.matatalab.com/vincibot/creatorkit>

To get more building forms, please check

Pour obtenir plus de formes de construction, veuillez vérifier

Um mehr Gebäudeformen zu erhalten, überprüfen Sie bitte

Per ottenere più forme di costruzione, controlla

Para obtener más formas de construcción, por favor revise

获取更多搭建形态, 请查阅

Чтобы получить больше форм строительства, пожалуйста, проверьте

หากต้องการรับรูปแบบสร้างสรรค์เพิ่มเติมโปรดตรวจสอบที่



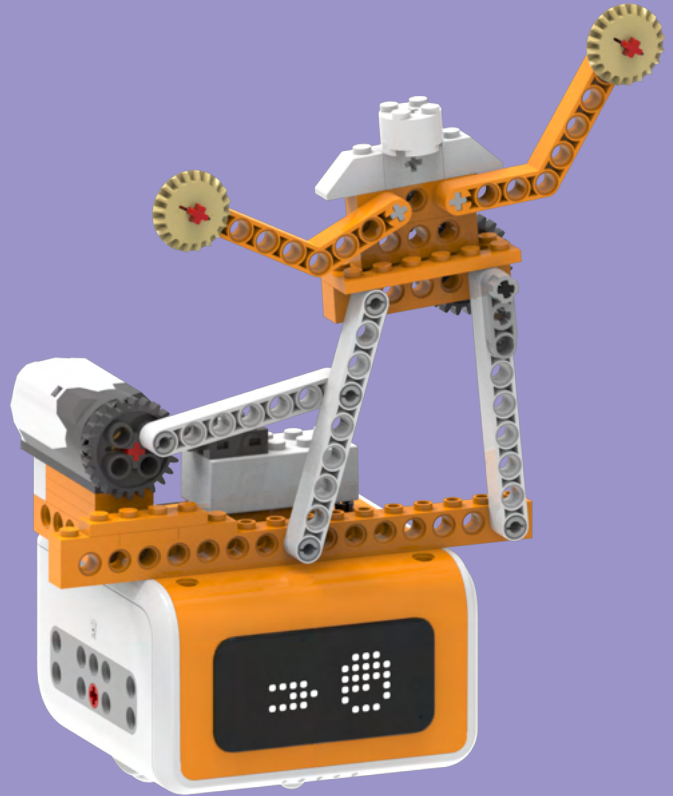



Case 1  
VinciBot is a Dancer

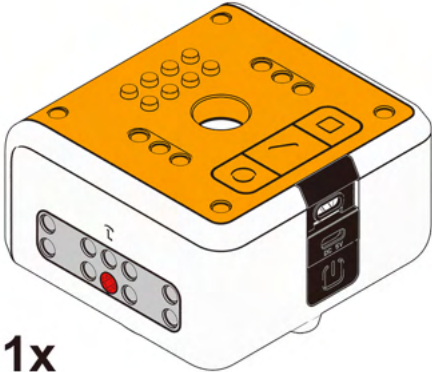









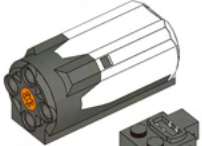



# Parts List

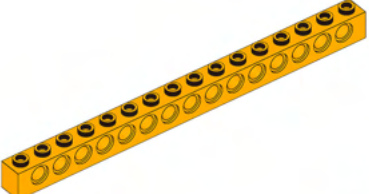
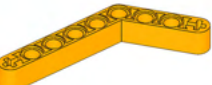
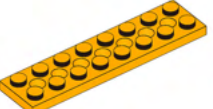

- 4M  
  
1x
-   
2x
-   
3x
-   
1x
- 3M  
  
2x
-   
5x
-   
1x
- 1x**

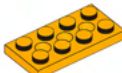
-   
2x
-   
1x
-   
1x
-   
1x
-   
2x
-   
2x
-   
3x
-   
2x

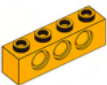
-   
1x
-   
2x
-   
1x
-   
2x
-   
3x
-   
4x

-   
2x
-   
1x
-   
2x

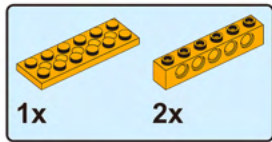

1

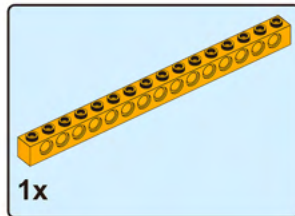
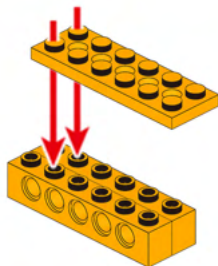

2

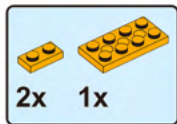
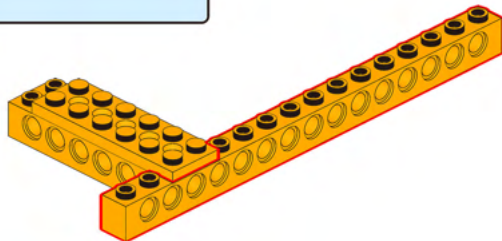

3

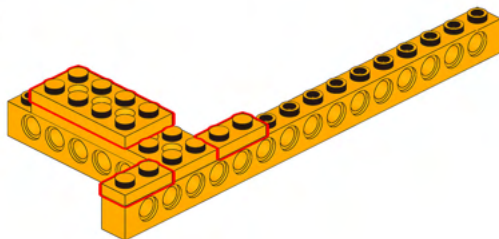

4

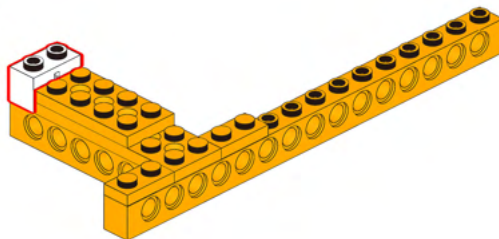

1

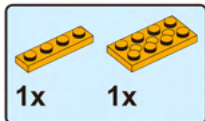

5

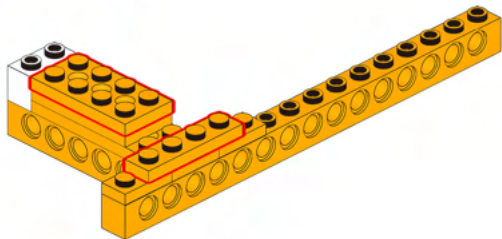

6

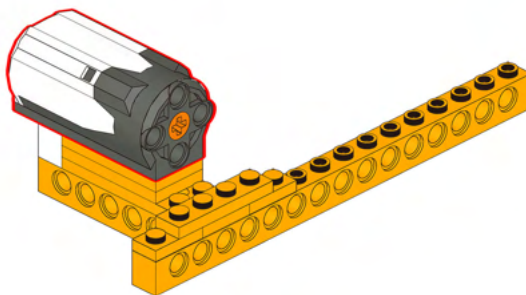

7

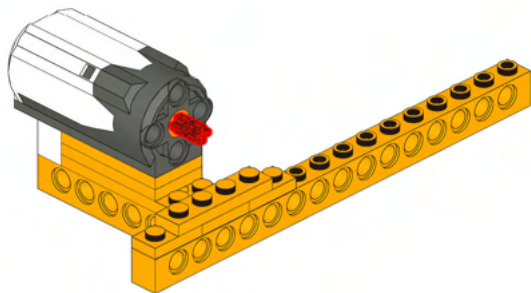

8

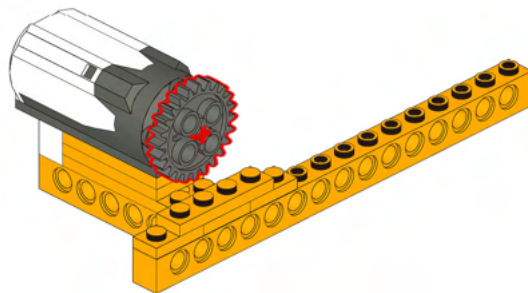



9

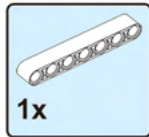
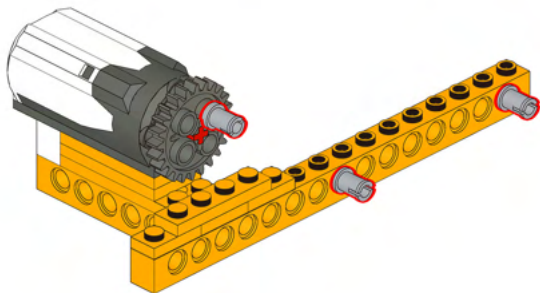

10

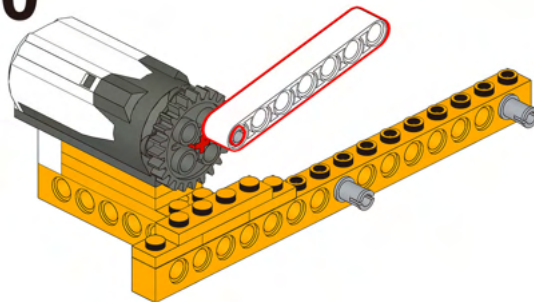

11

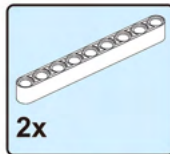
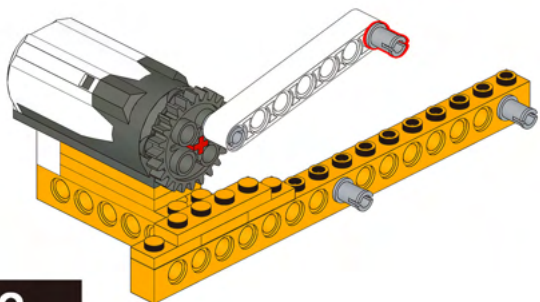

12

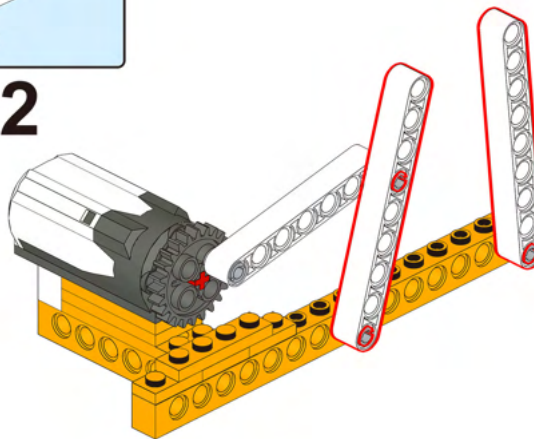

3

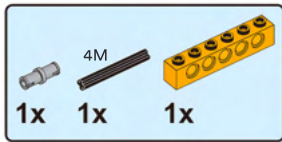

13

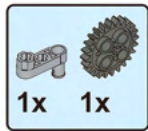
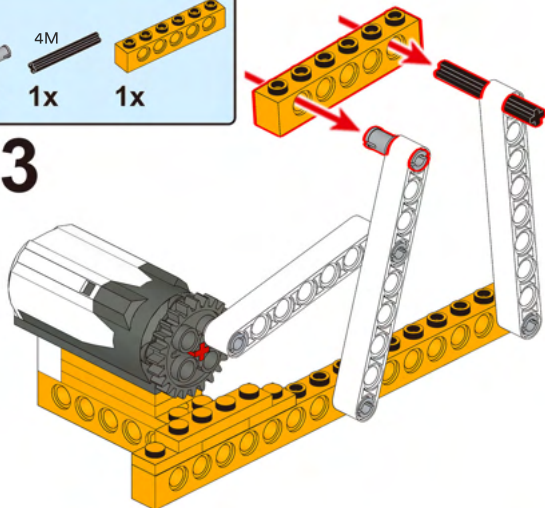

14

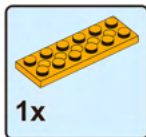
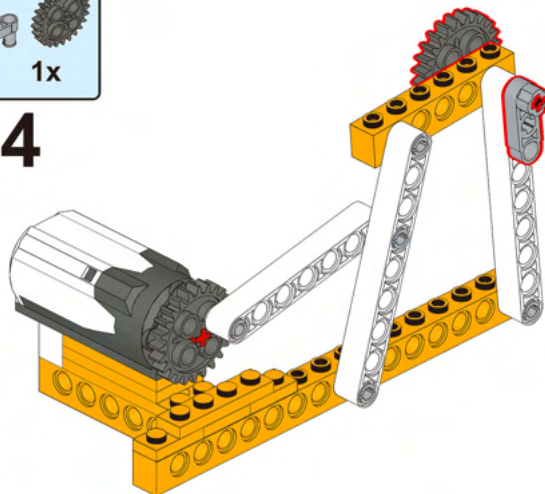

15

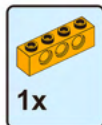
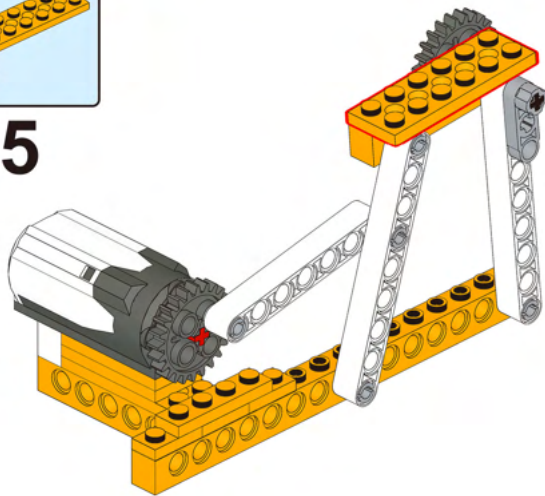

16

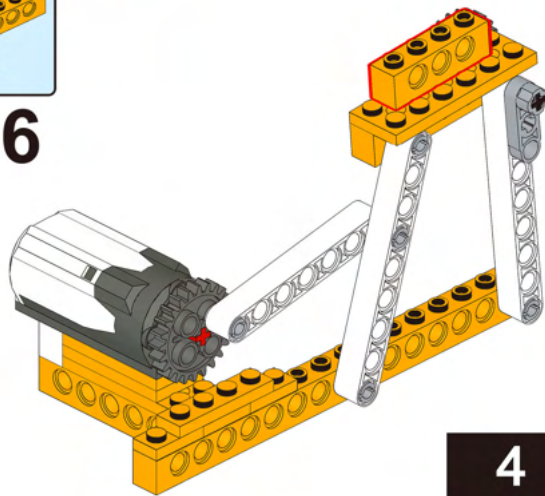



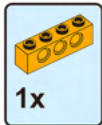

1x

17

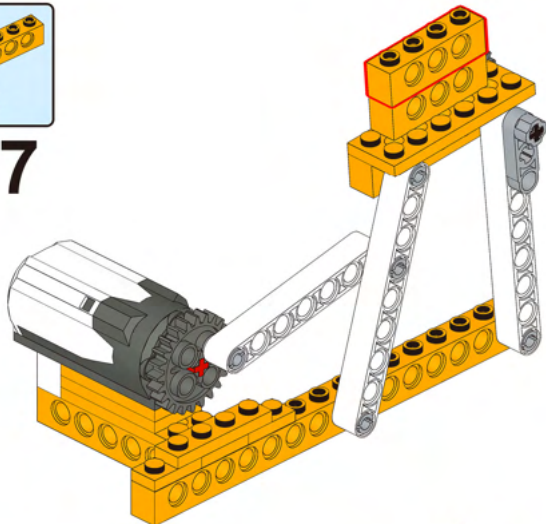

1x

18

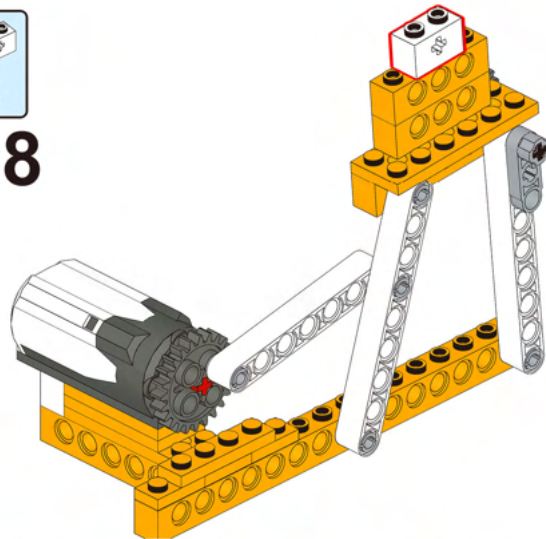

2x

19

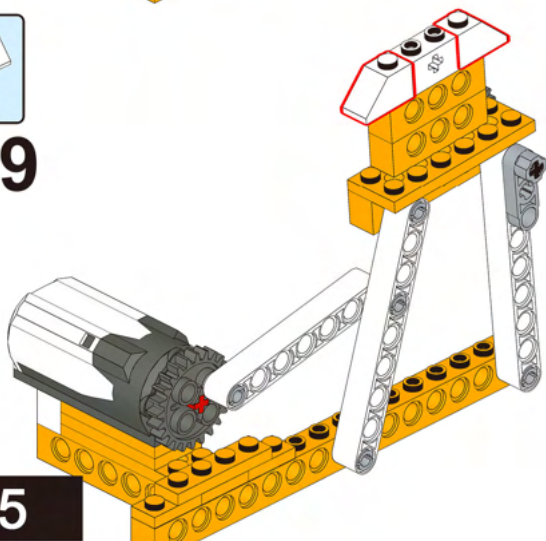

1x

20

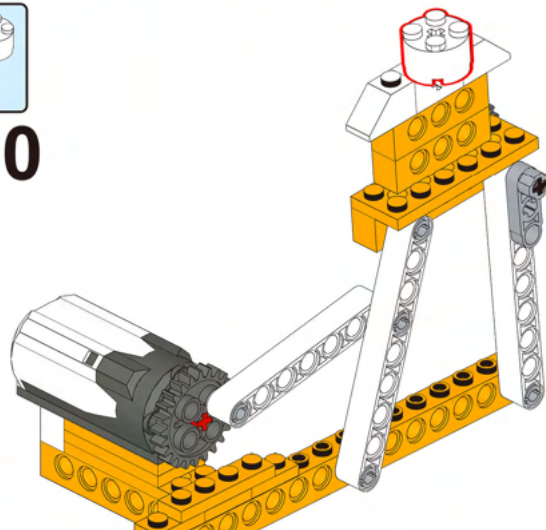

5

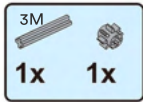

21

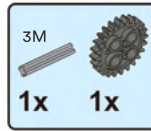
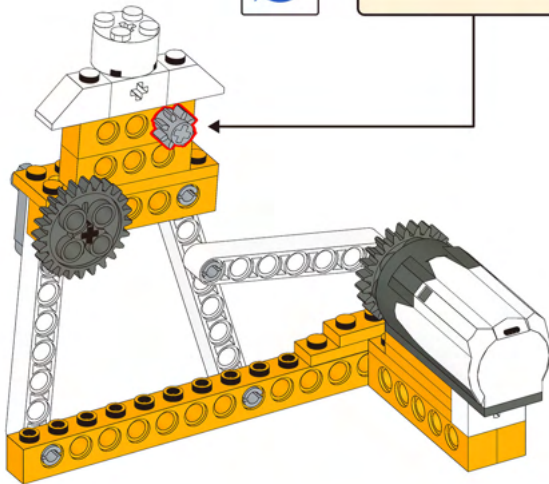
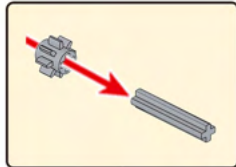

22

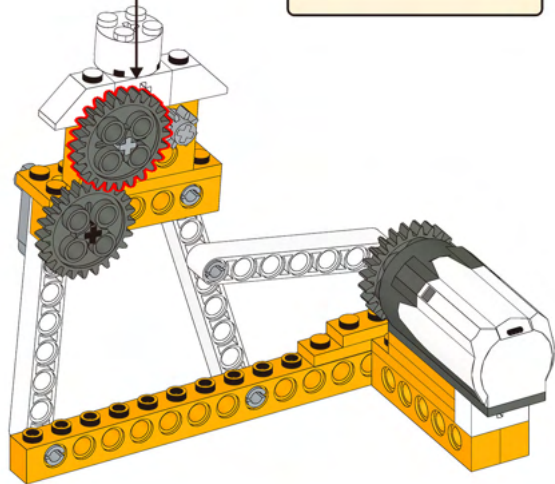
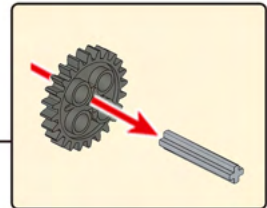

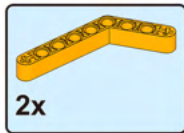

23

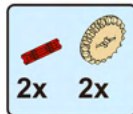
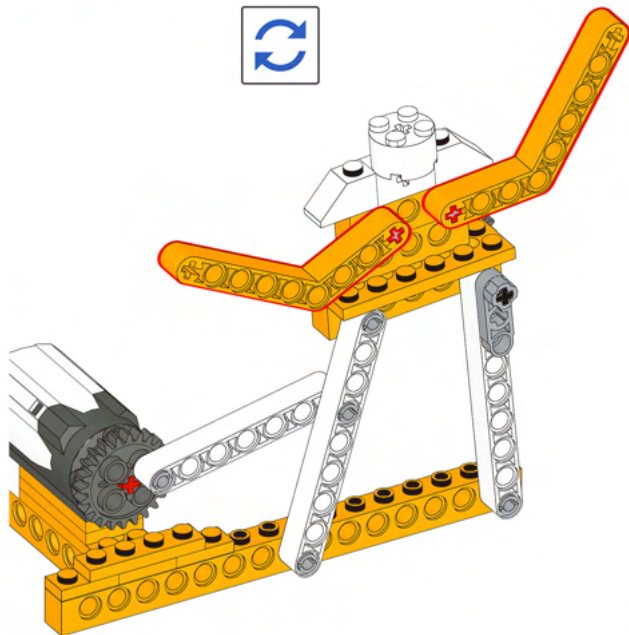

24

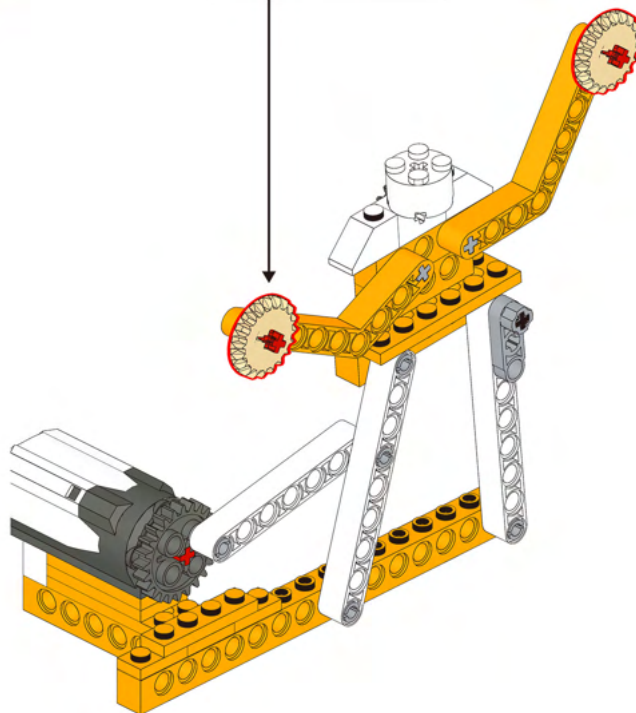
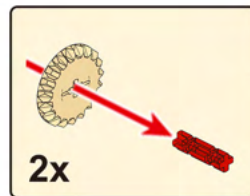



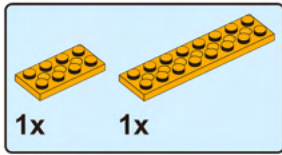

25

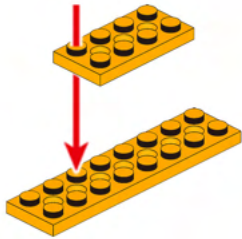

27

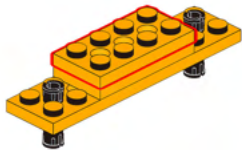

26

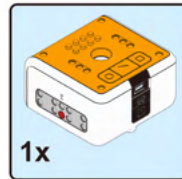
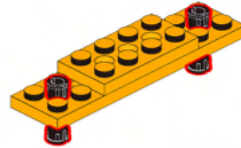

28

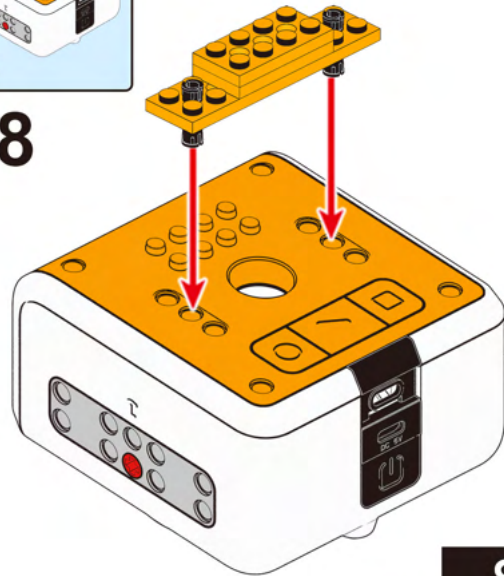

29

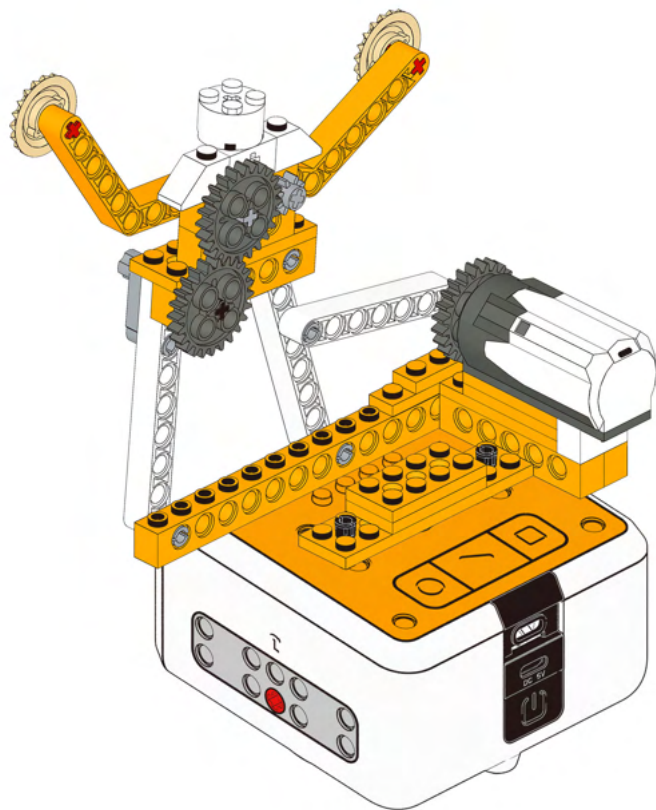

9

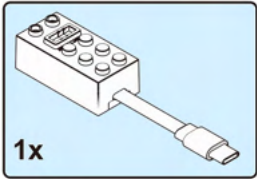

30

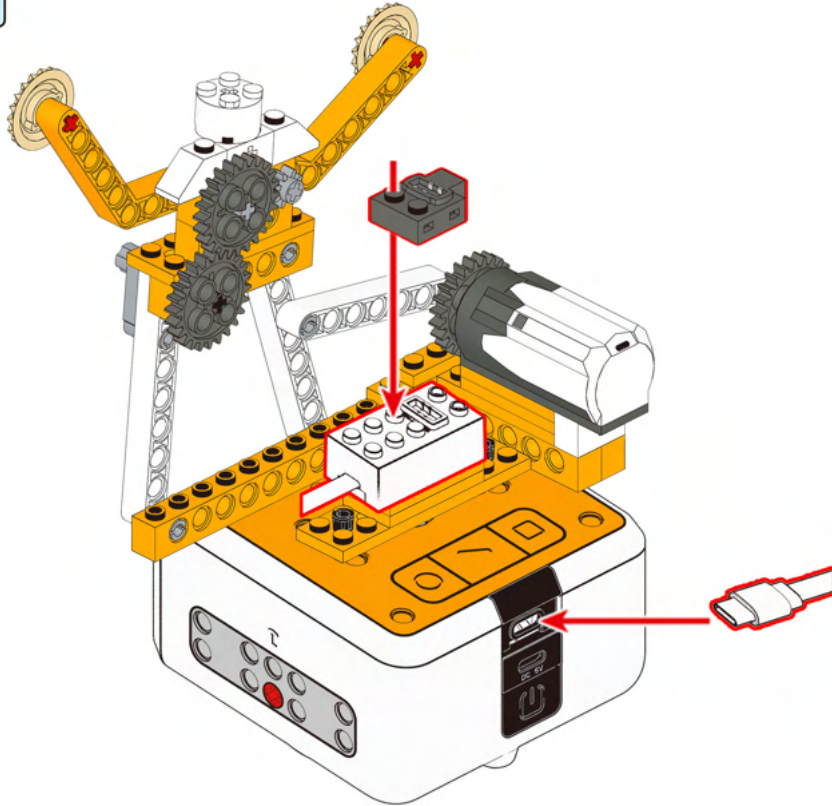

# Demo Program

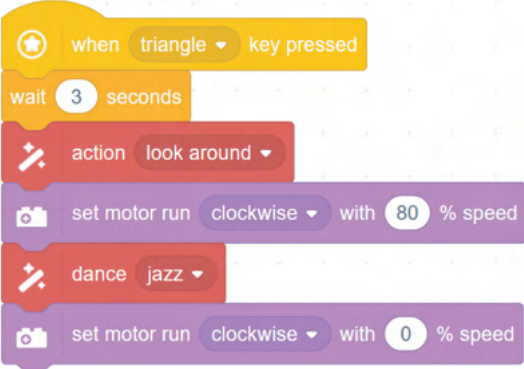

```
when triangle key pressed
wait 3 seconds
action look around
set motor run clockwise with 80 % speed
dance jazz
set motor run clockwise with 0 % speed
```

A Scratch code block starting with a yellow 'when key pressed' block set to 'triangle'. It is followed by a yellow 'wait 3 seconds' block, a red 'action look around' block, a purple 'set motor run clockwise with 80 % speed' block, a red 'dance jazz' block, and a purple 'set motor run clockwise with 0 % speed' block.

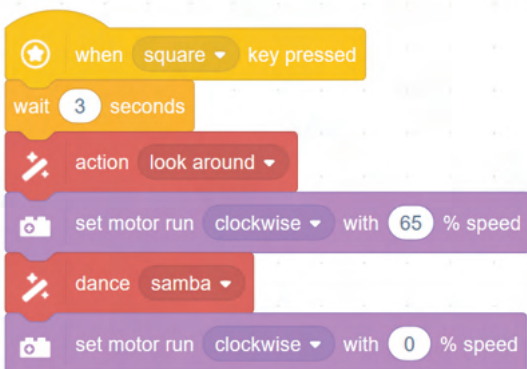

```
when square key pressed
wait 3 seconds
action look around
set motor run clockwise with 65 % speed
dance samba
set motor run clockwise with 0 % speed
```

A Scratch code block starting with a yellow 'when key pressed' block set to 'square'. It is followed by a yellow 'wait 3 seconds' block, a red 'action look around' block, a purple 'set motor run clockwise with 65 % speed' block, a red 'dance samba' block, and a purple 'set motor run clockwise with 0 % speed' block.



## Case 2 Big Pendulum Ride

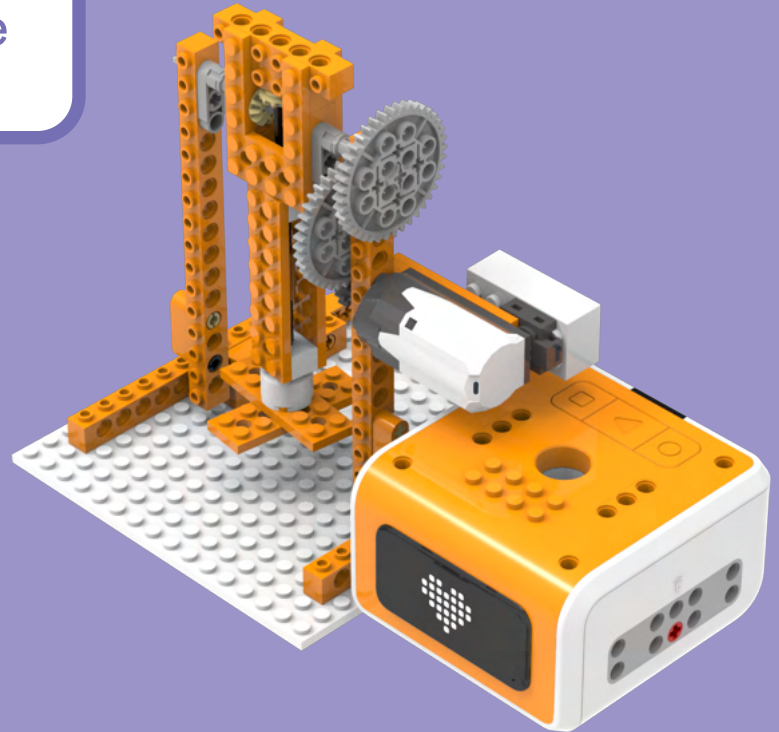

# Parts List

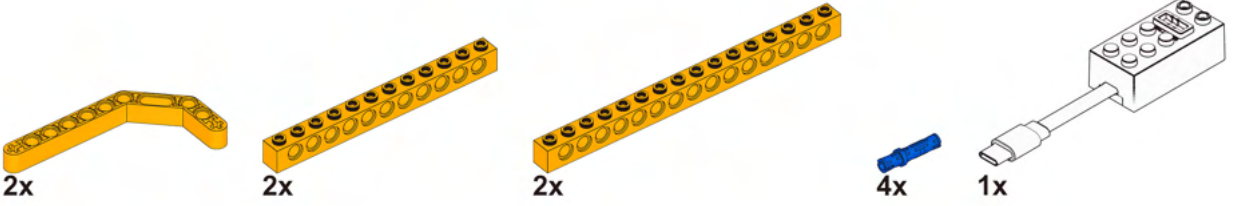
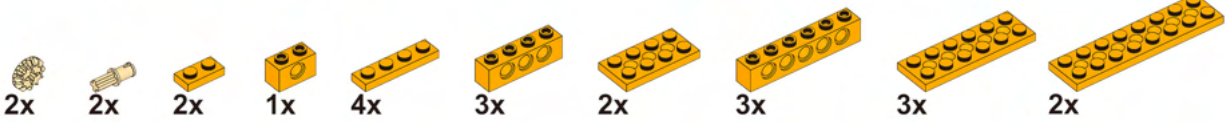
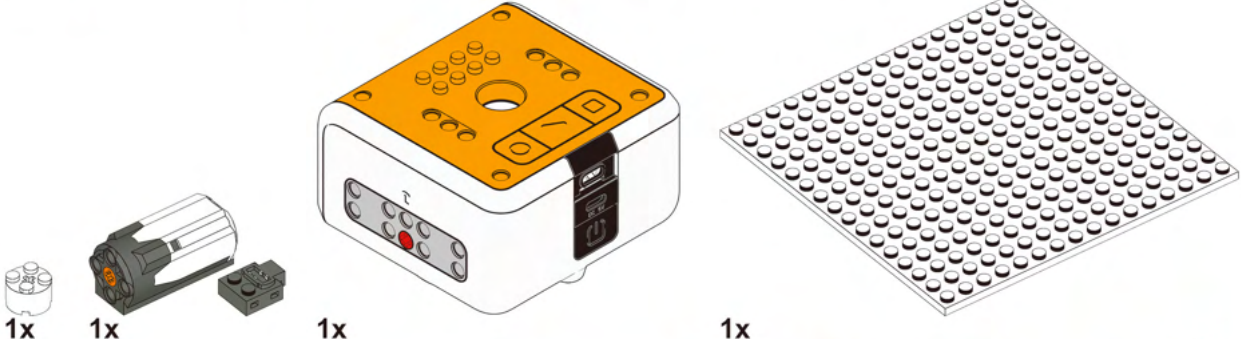
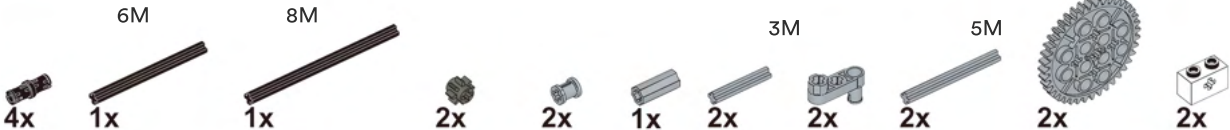

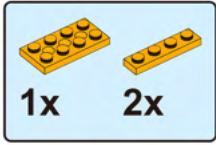

1

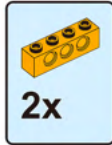

2

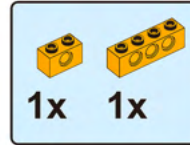
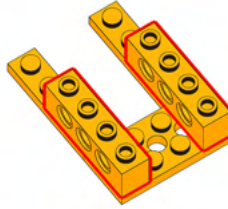

3

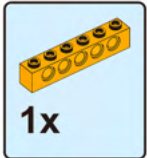
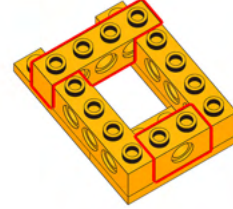

4

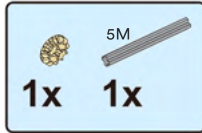
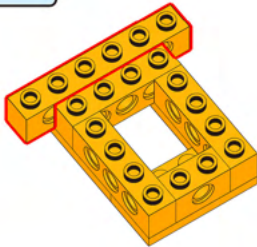

5

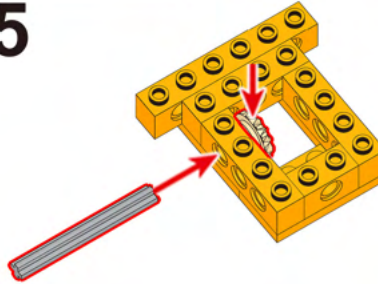

6

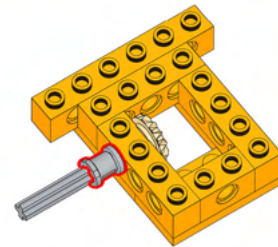

1



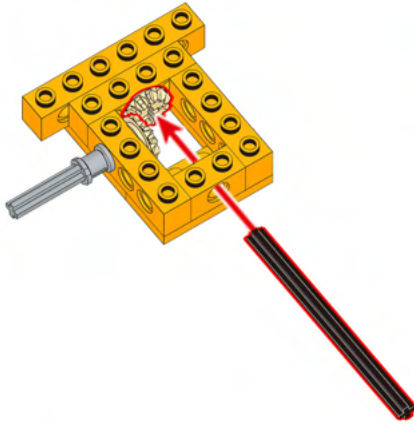
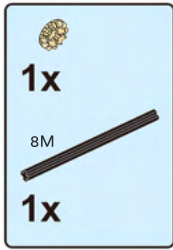

7

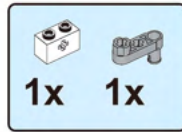

8

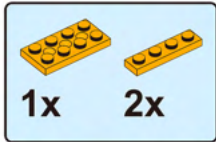
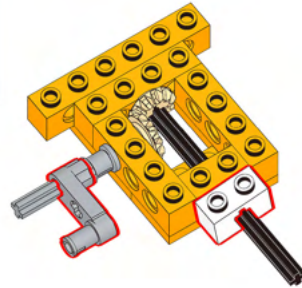

9

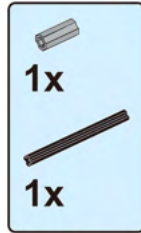
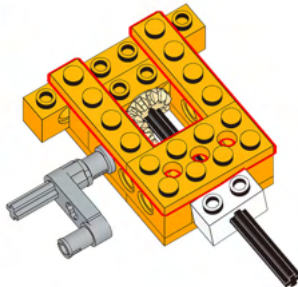

10

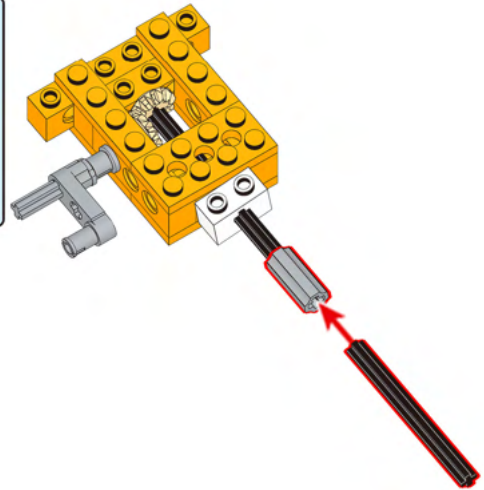

2



1x

11

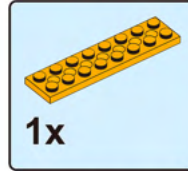

1x

12

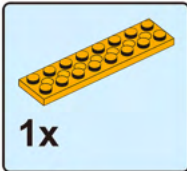

1x

13

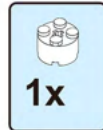

1x

14

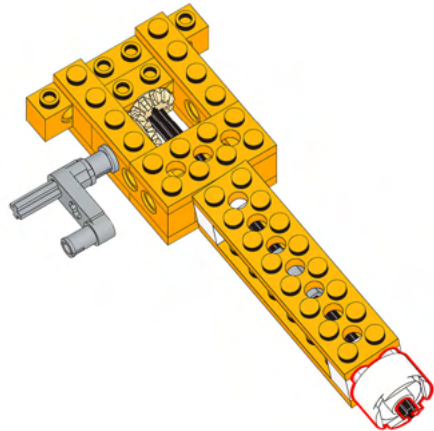

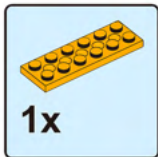

15

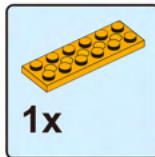
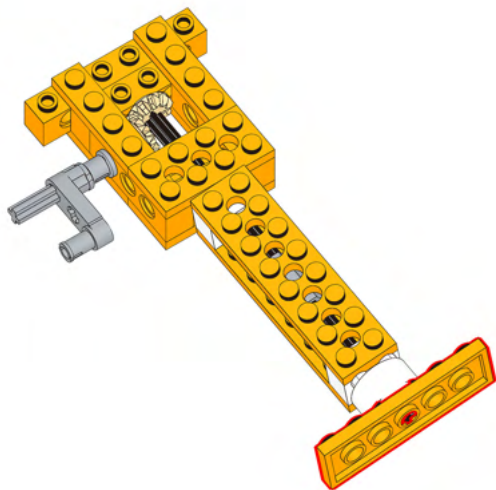

16

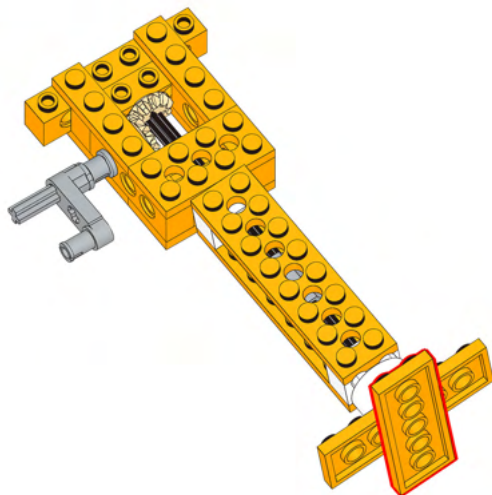

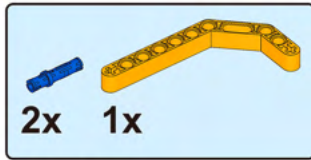

17

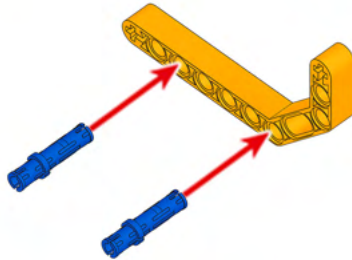

18

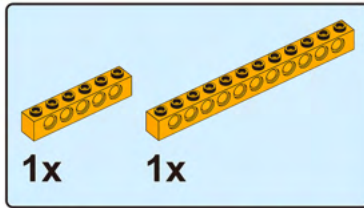
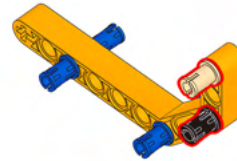

19

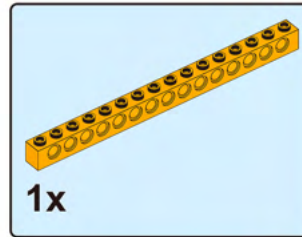
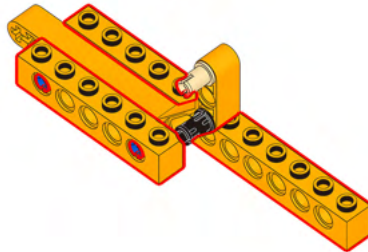

20

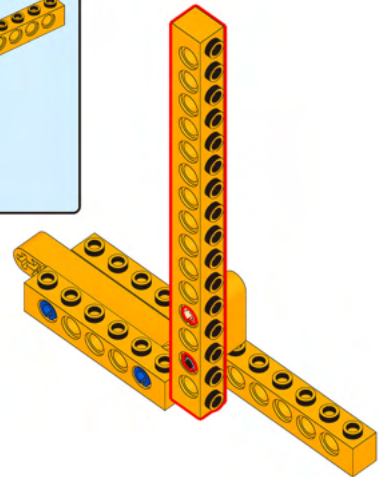



21

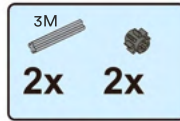
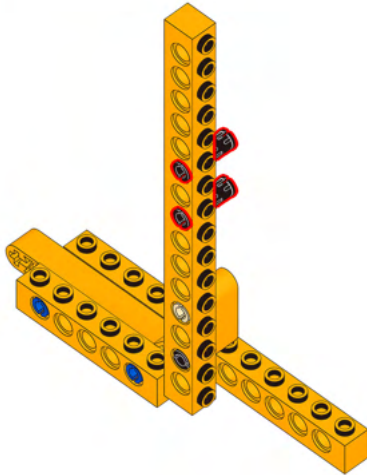

22

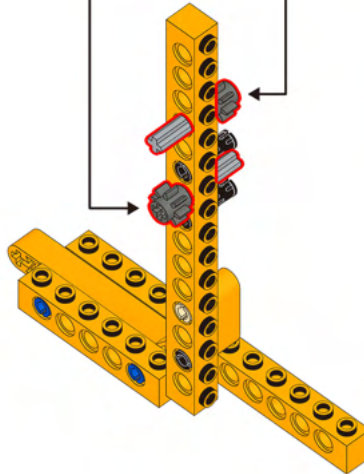
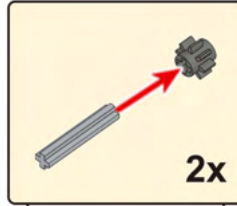

23

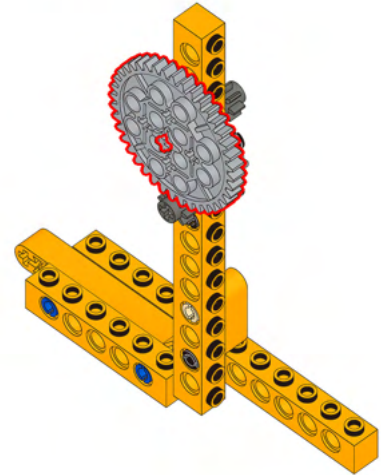

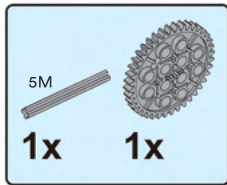

24

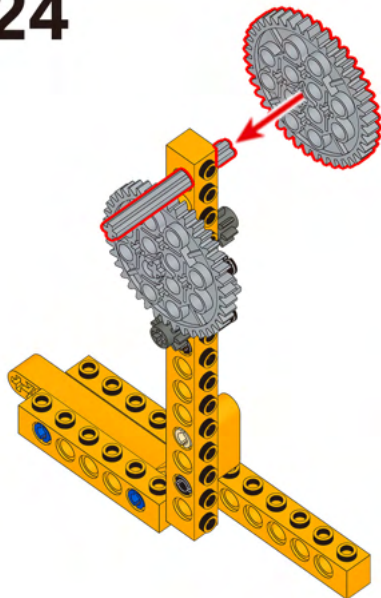

25

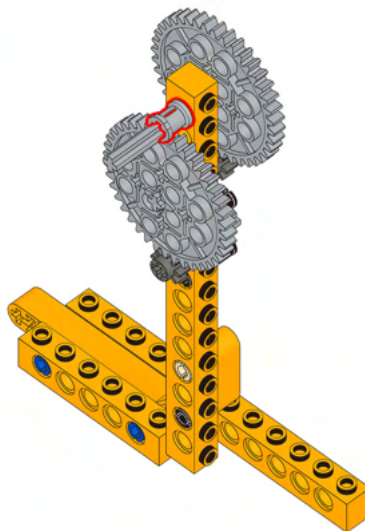

26

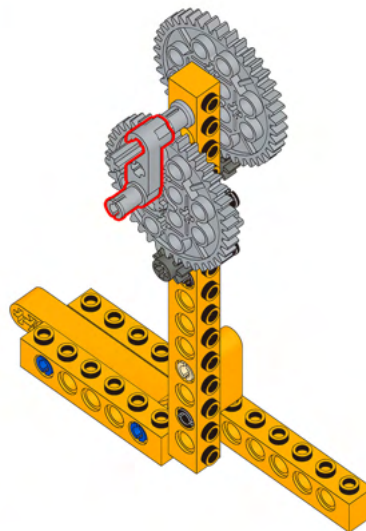

27

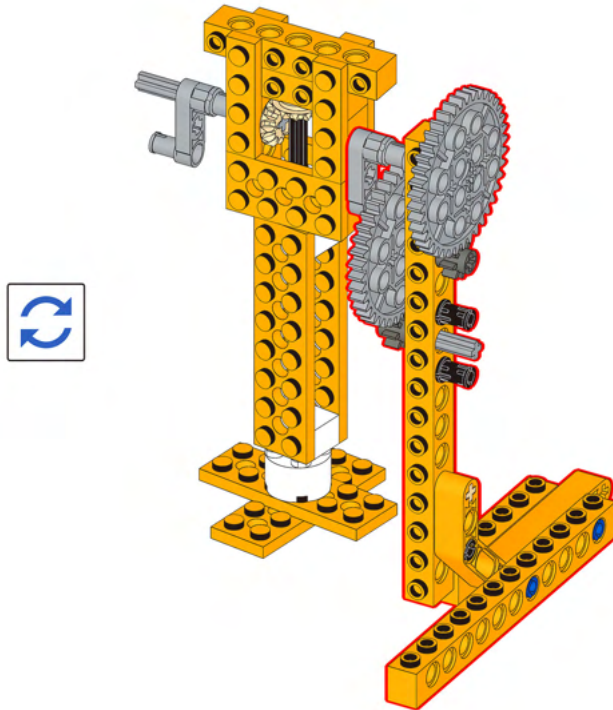



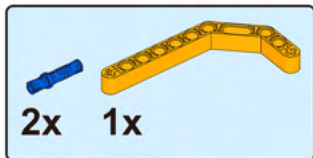

28

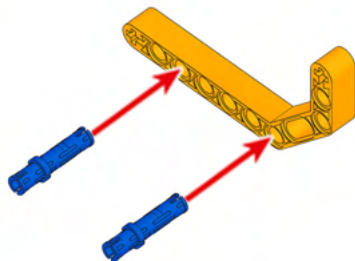

29

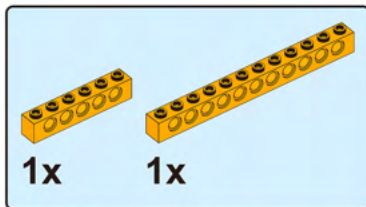
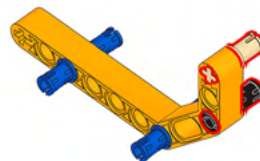

30

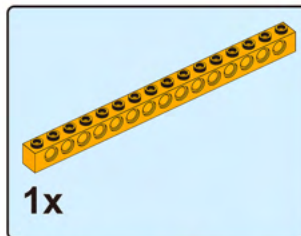
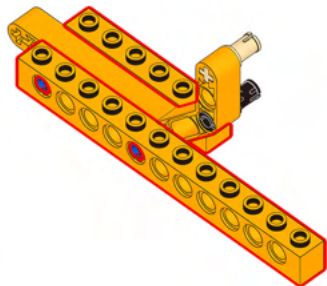

31

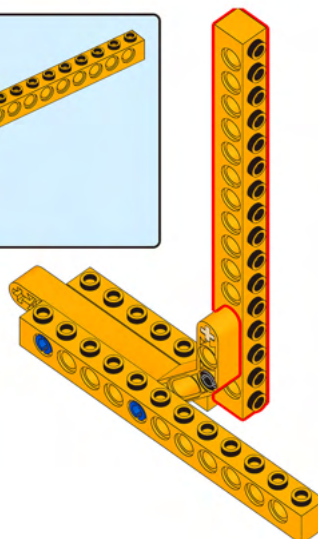



32

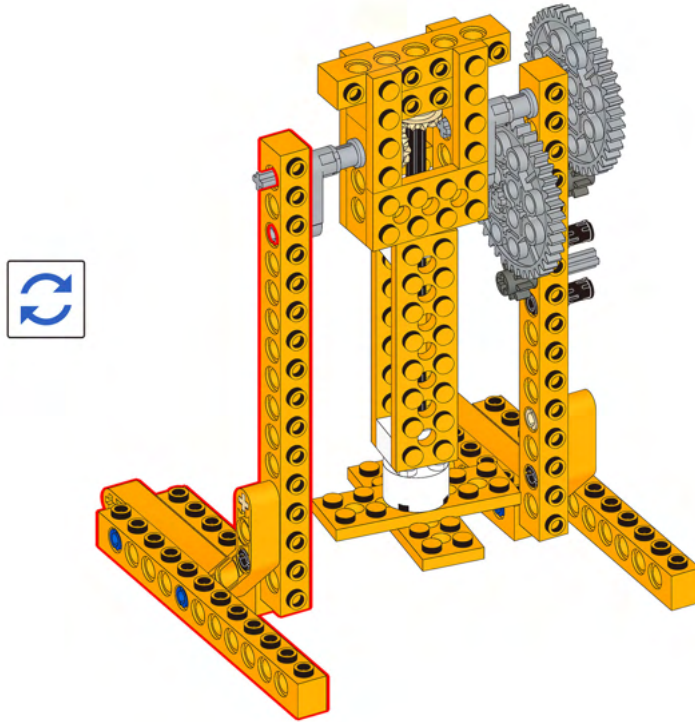

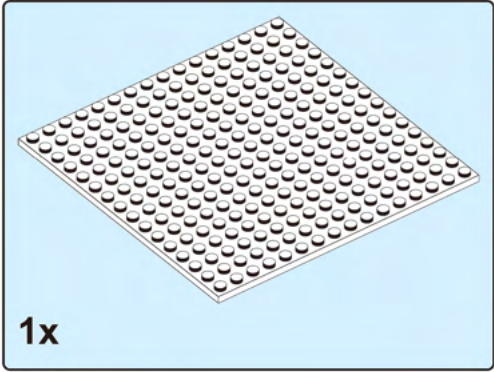

33

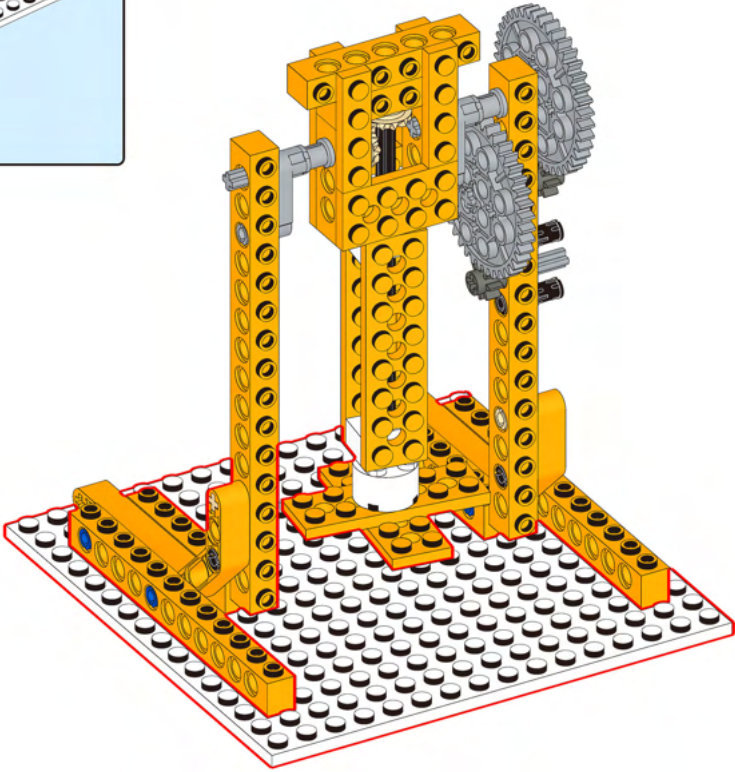



1x

34

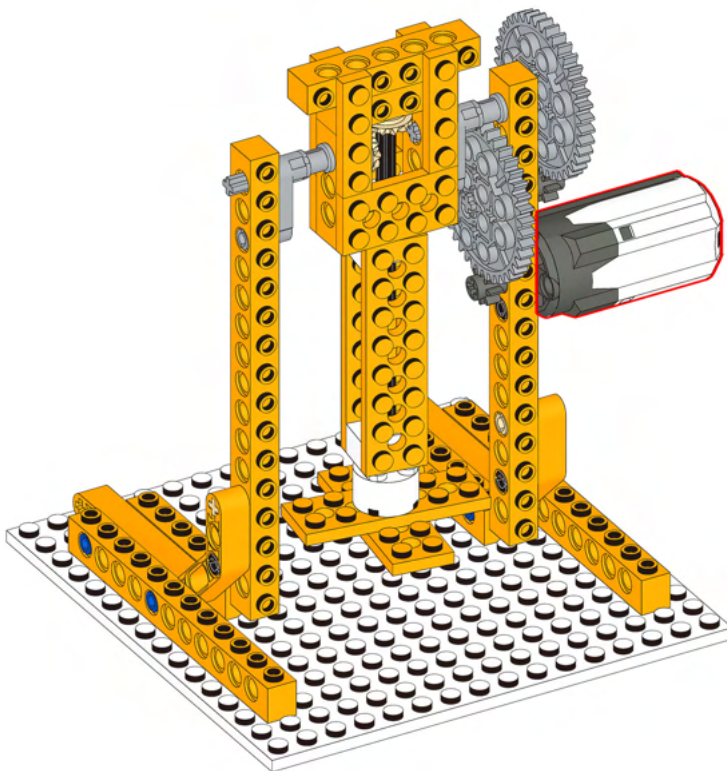

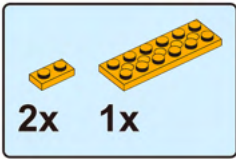

35

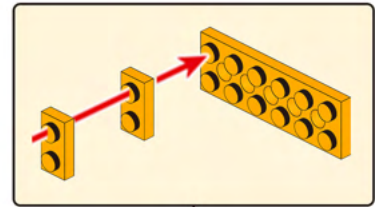
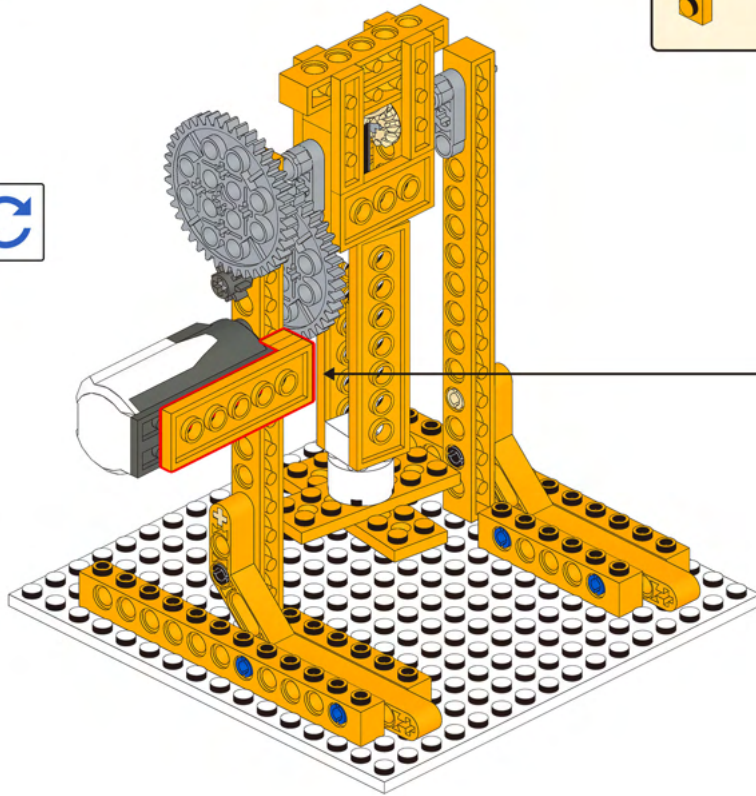



36

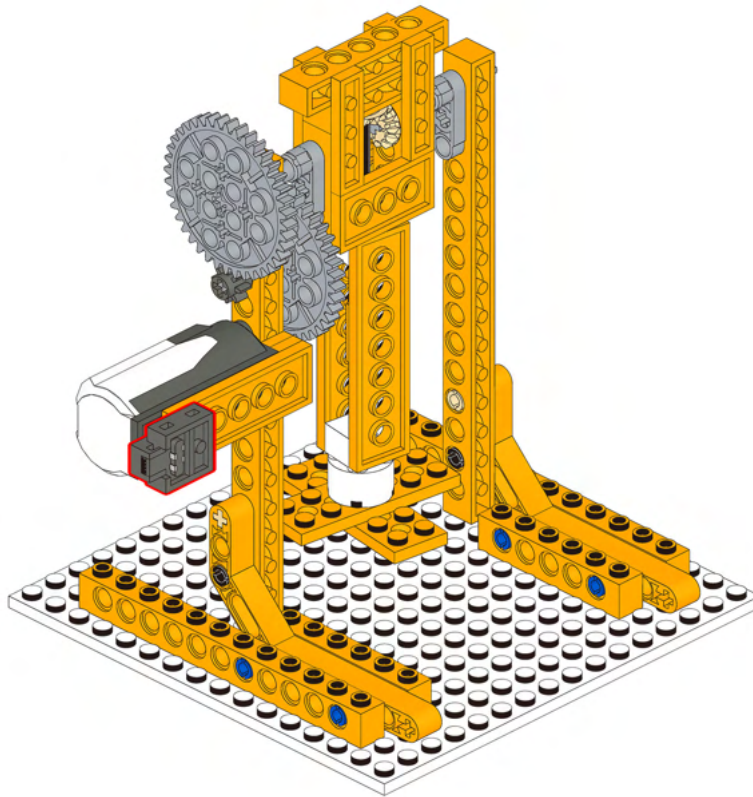

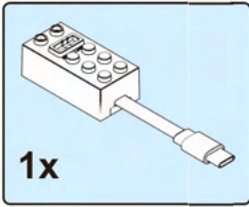

1x

37

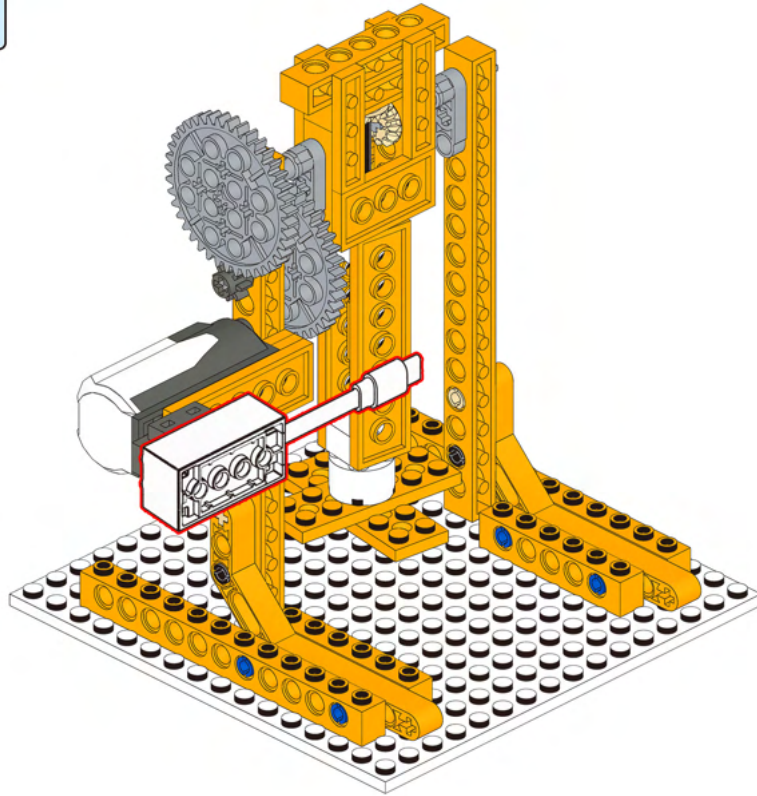

15



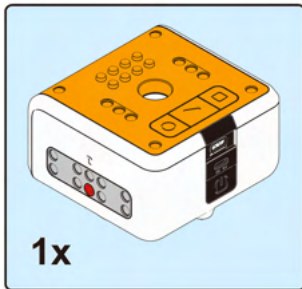

38

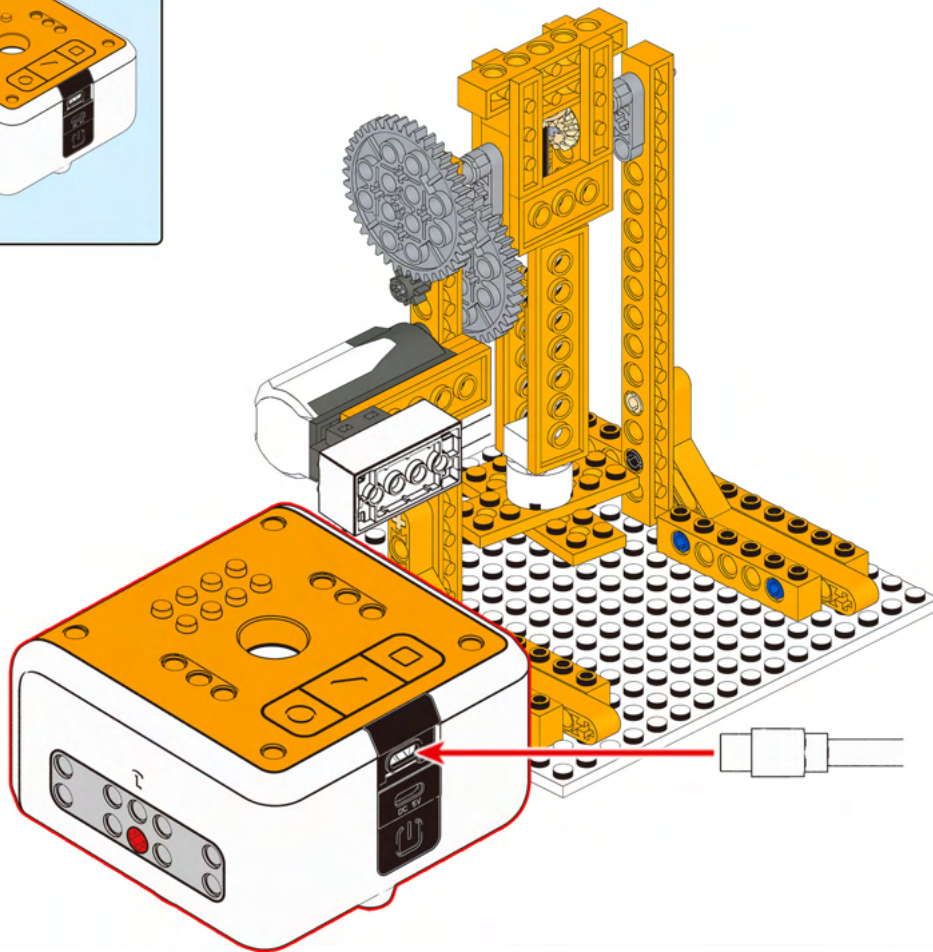

39

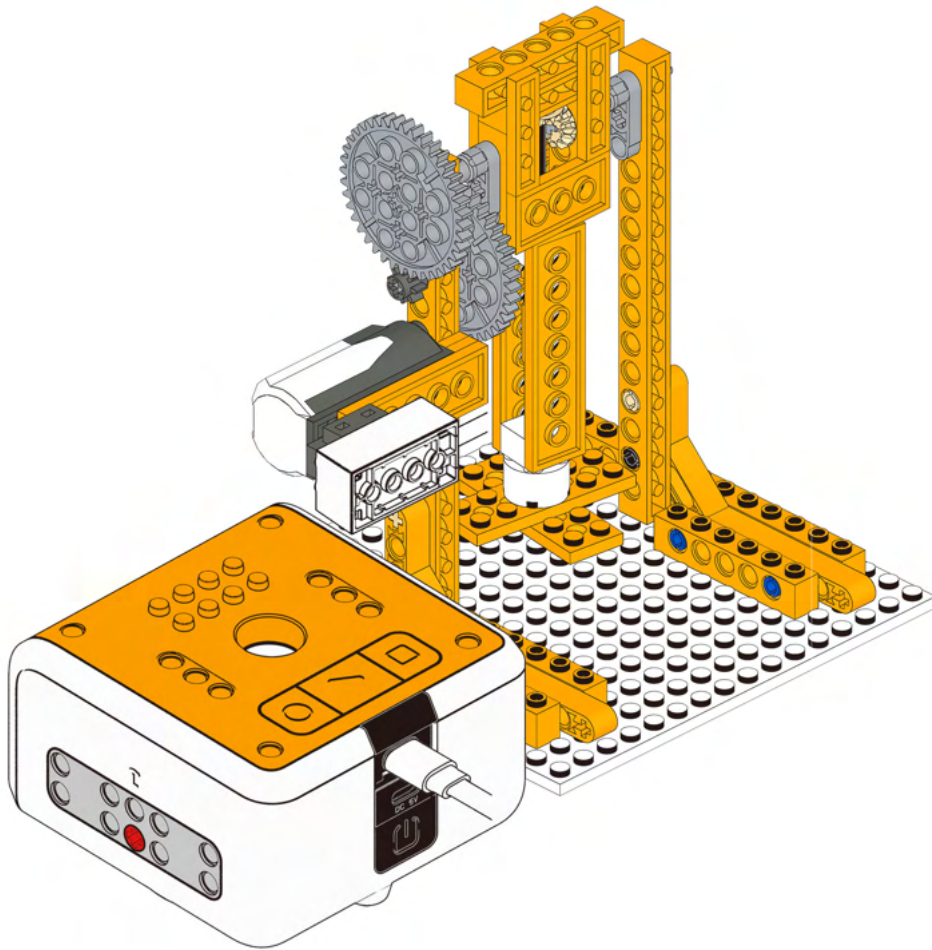

17



# Demo Program

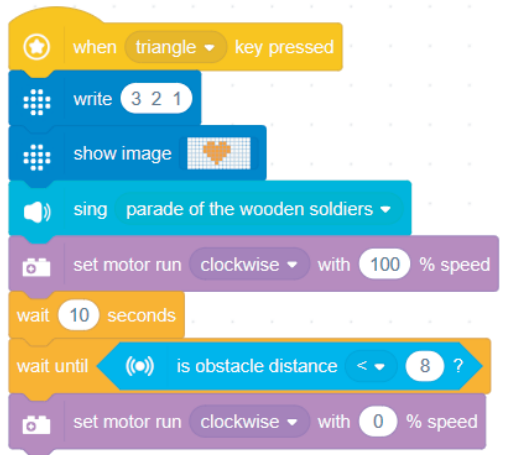

## Case 3 Mechanical Claw

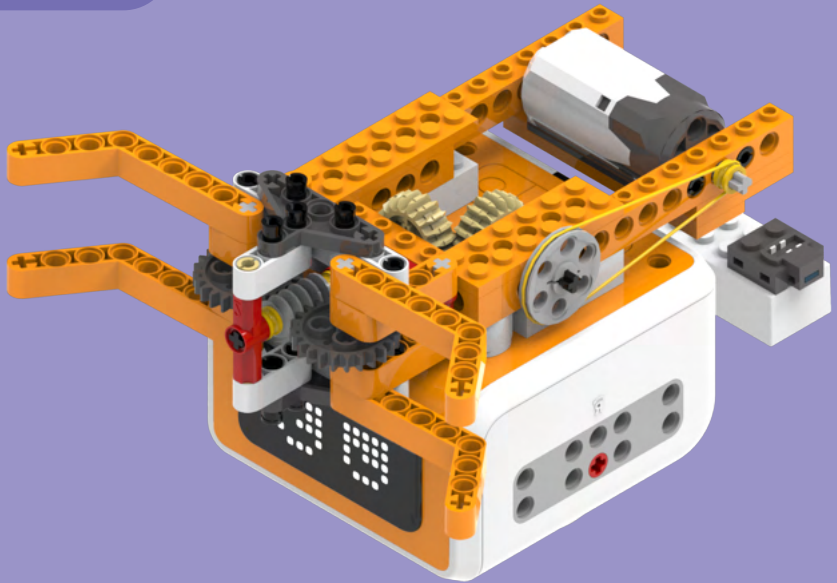

# Parts List

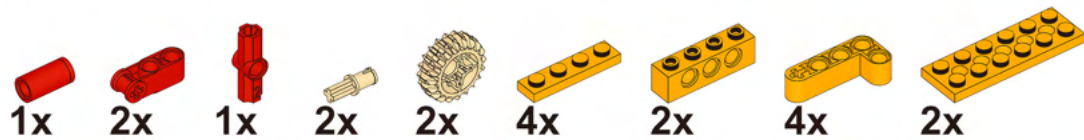
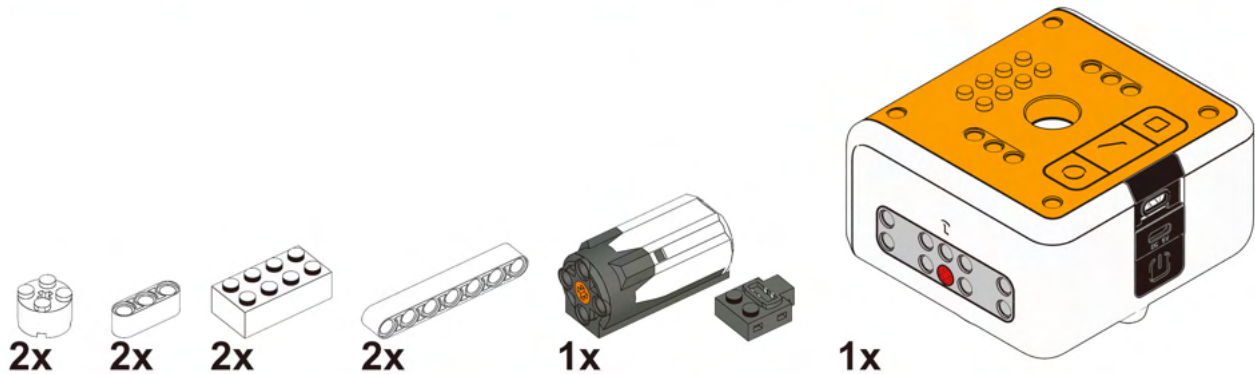

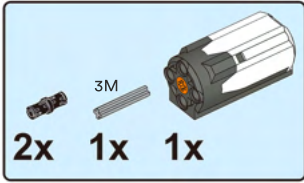

1

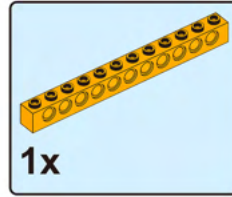
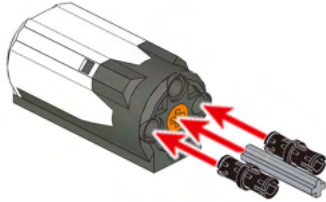

2

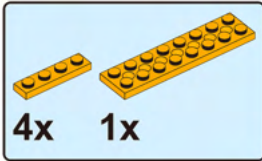
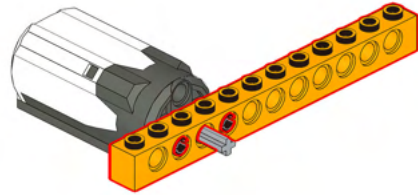

3

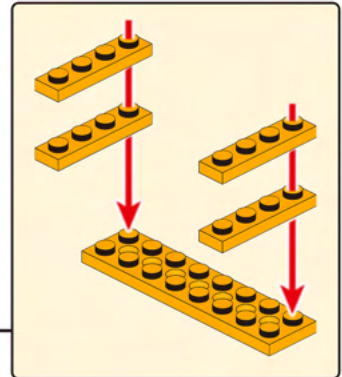
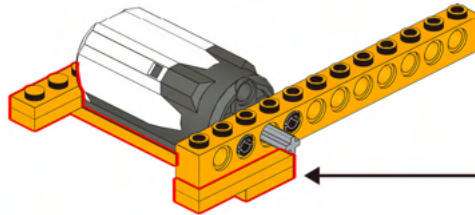

1

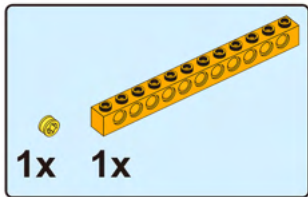

4

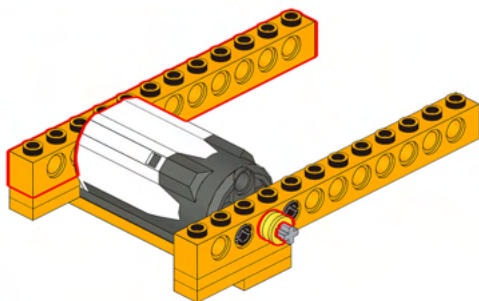

5

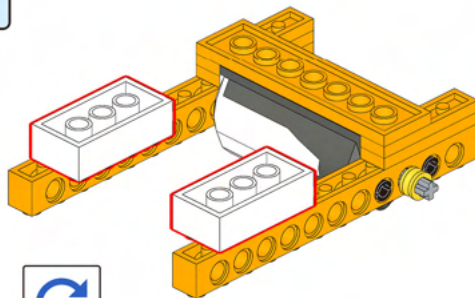

6

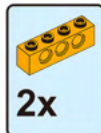
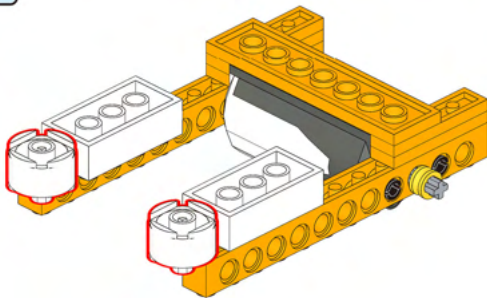

7

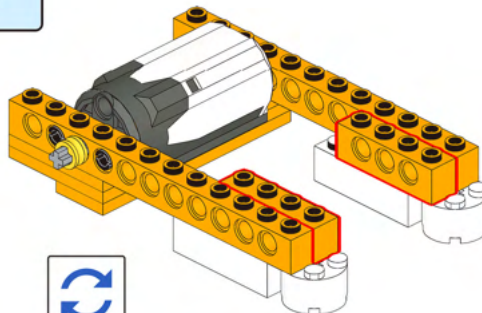



8

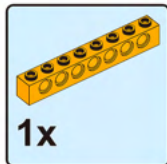
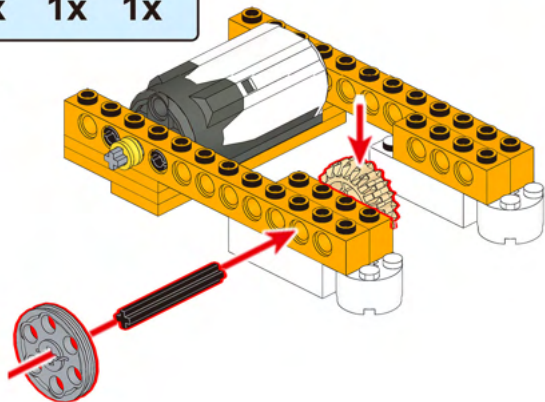

9

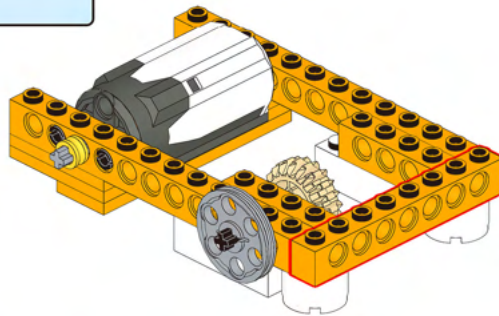

10

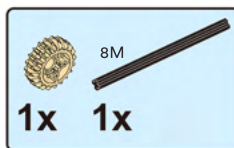
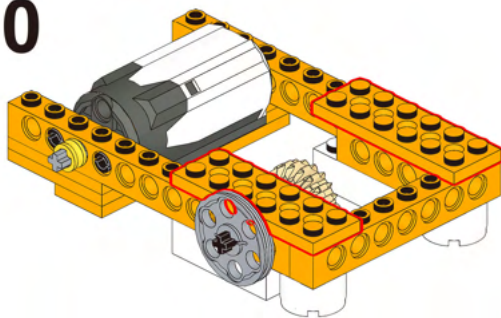

11

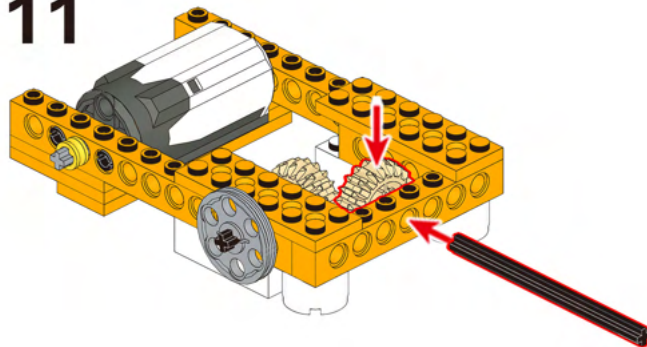

3





12

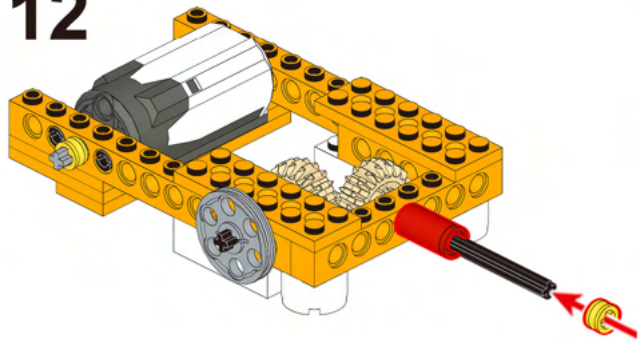

13

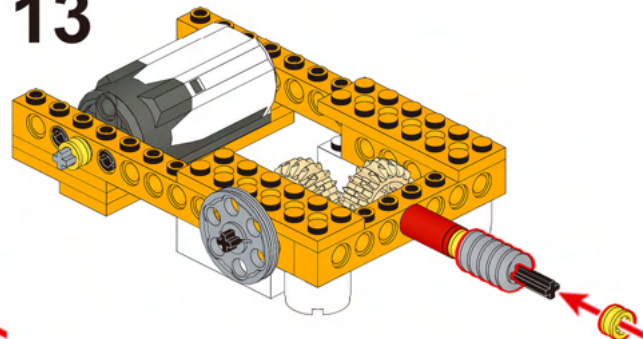

14

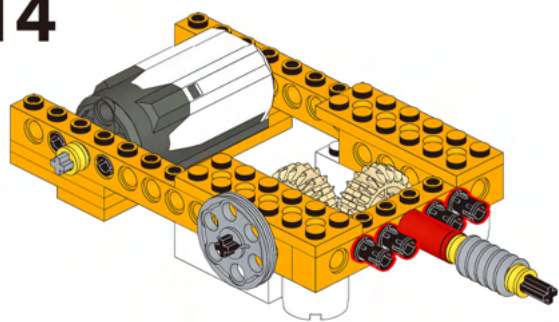

15

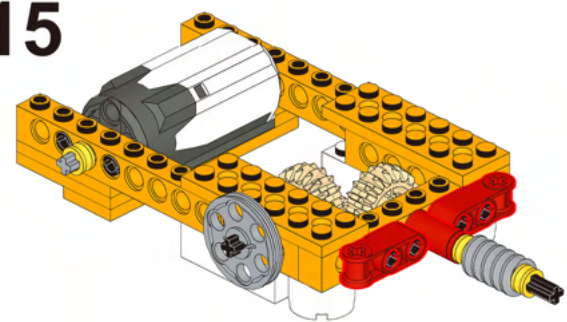





16

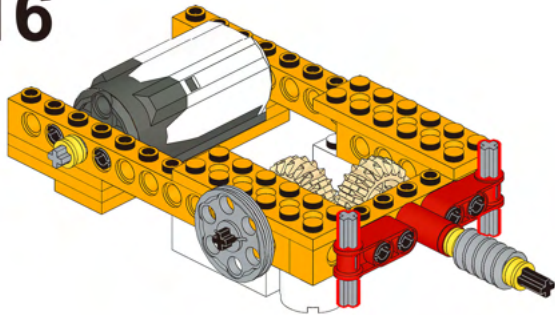

17

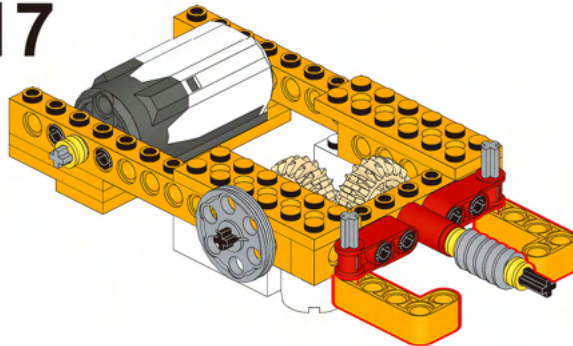

18

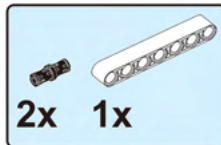
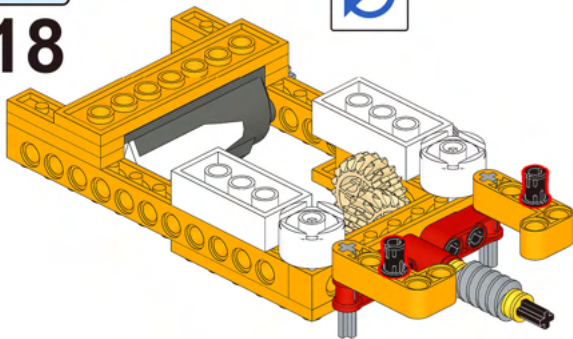

19

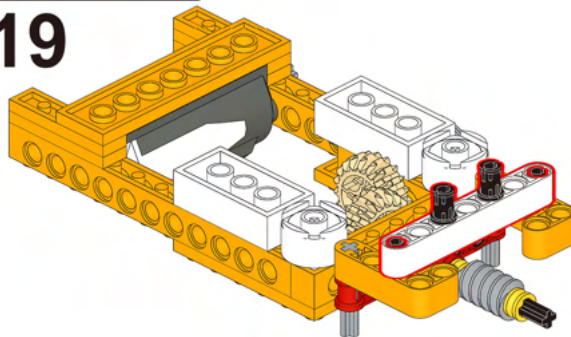

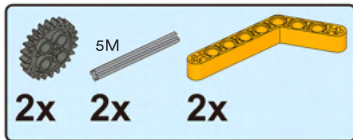

20

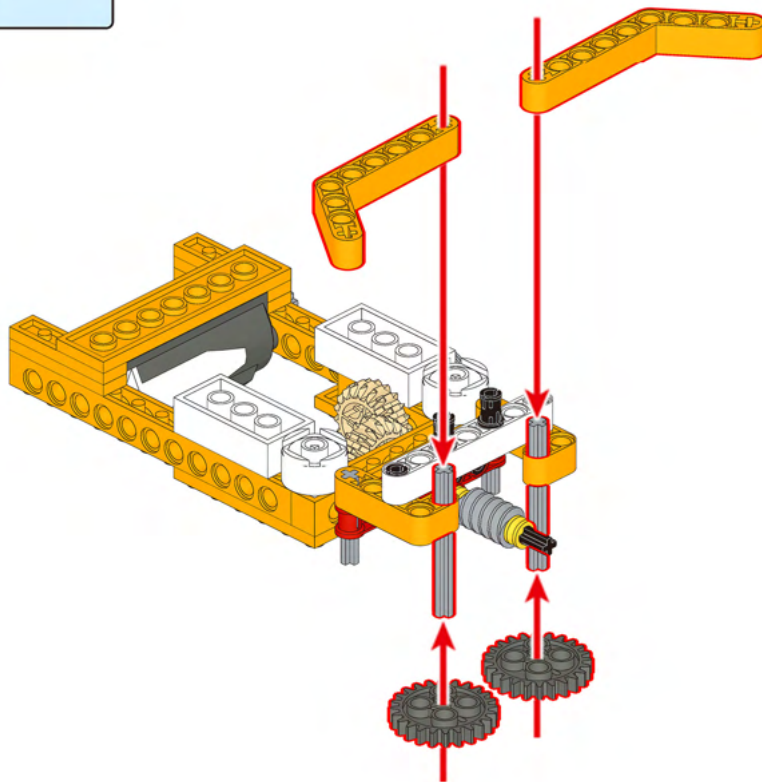



21

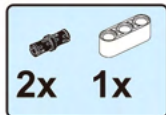
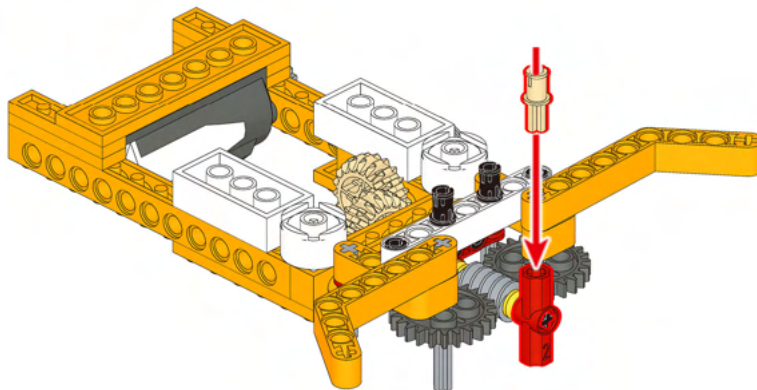

22

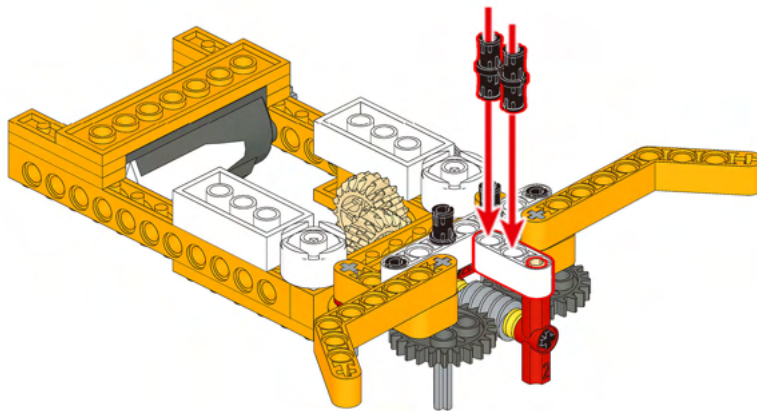

7



23

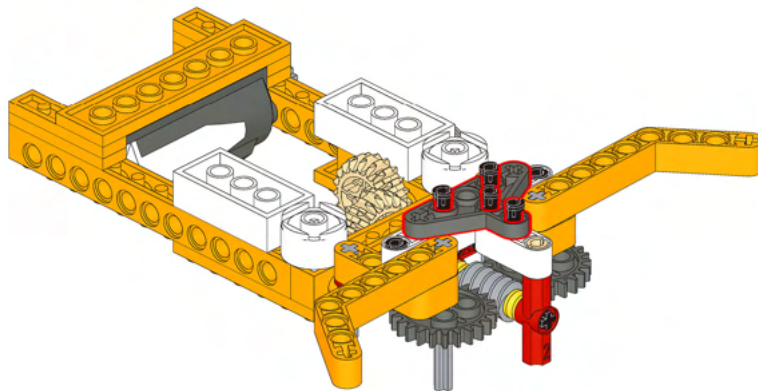

24

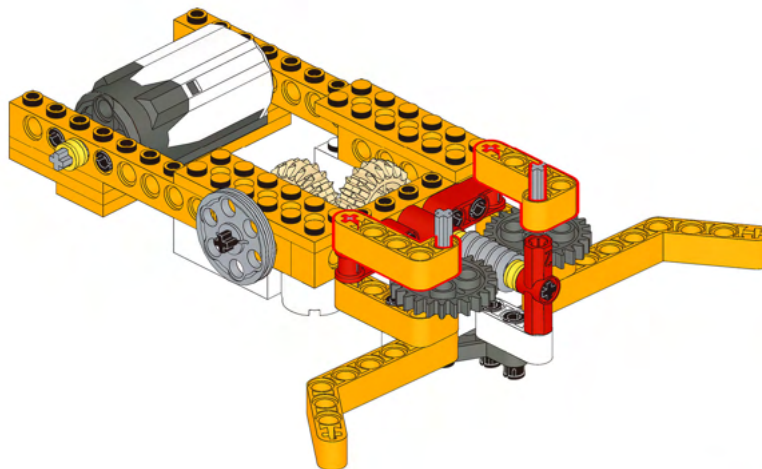



25

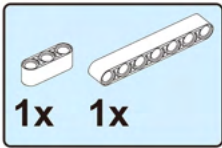
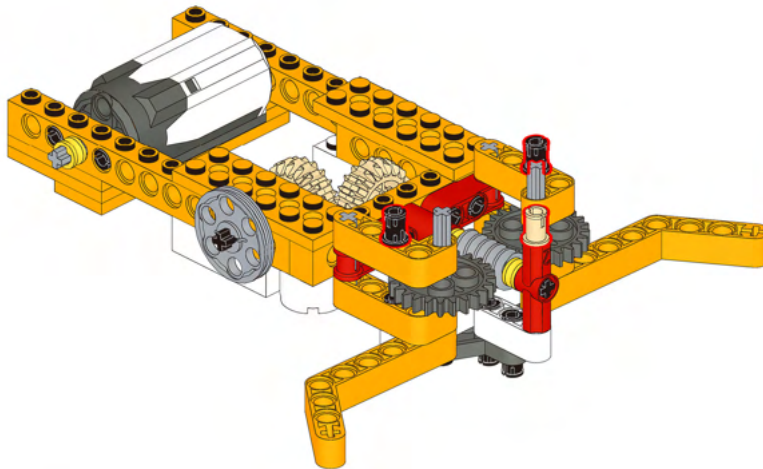

26

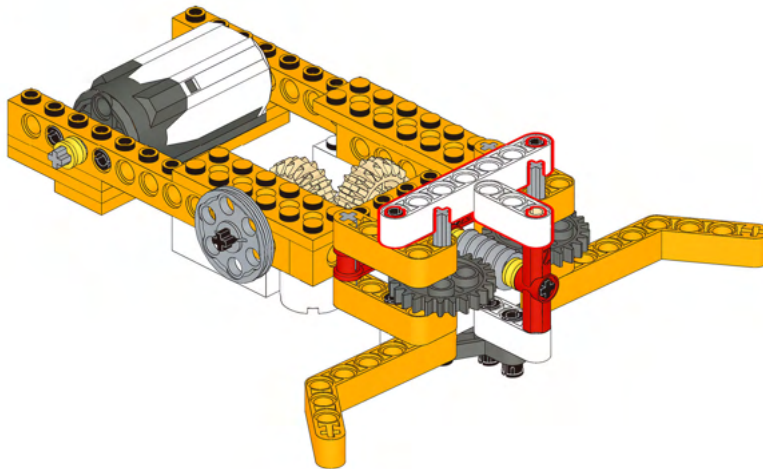

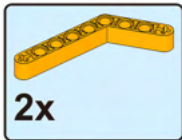

27

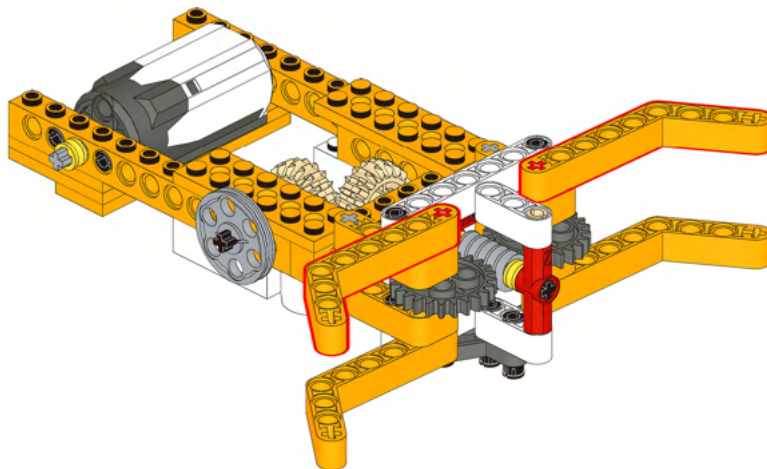

28

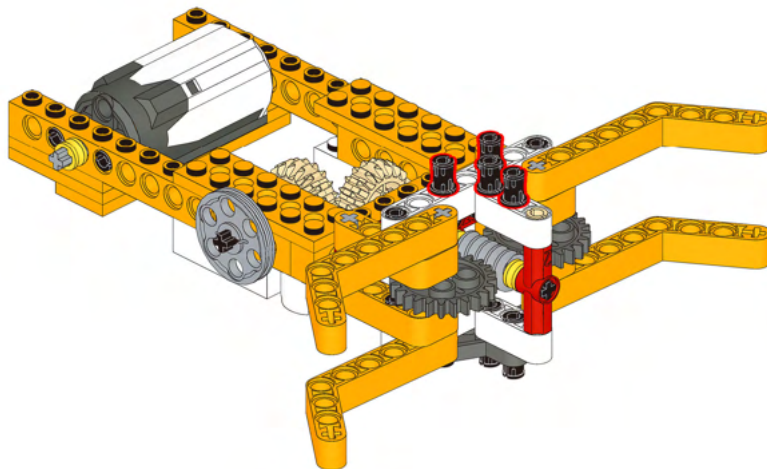





1x

29

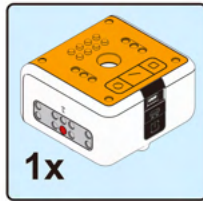
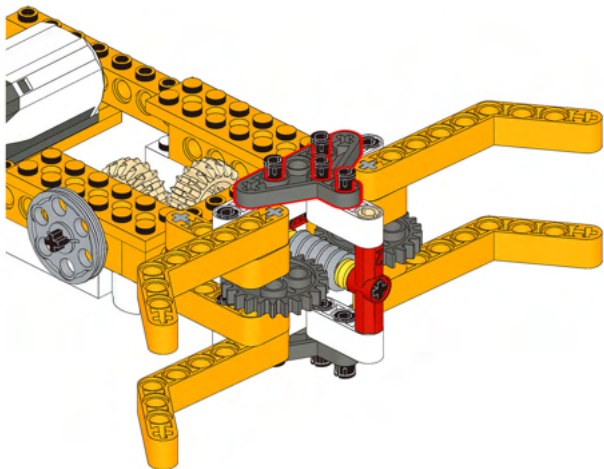

1x

30

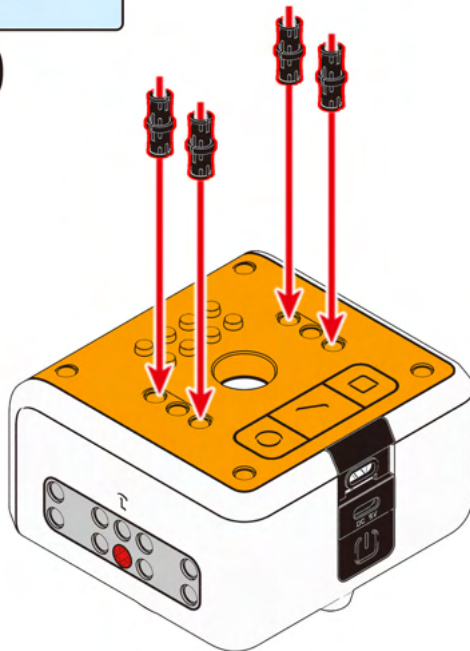



31

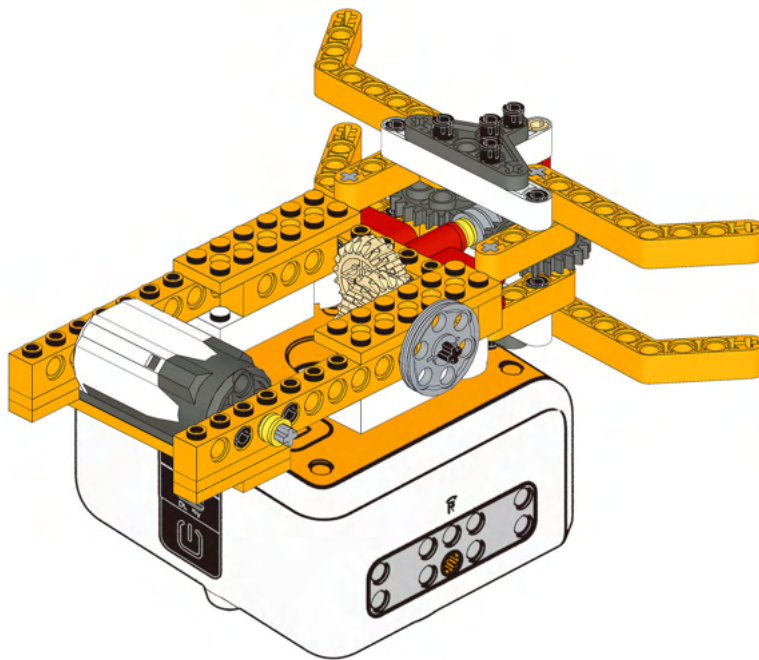

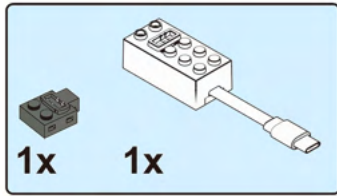

32

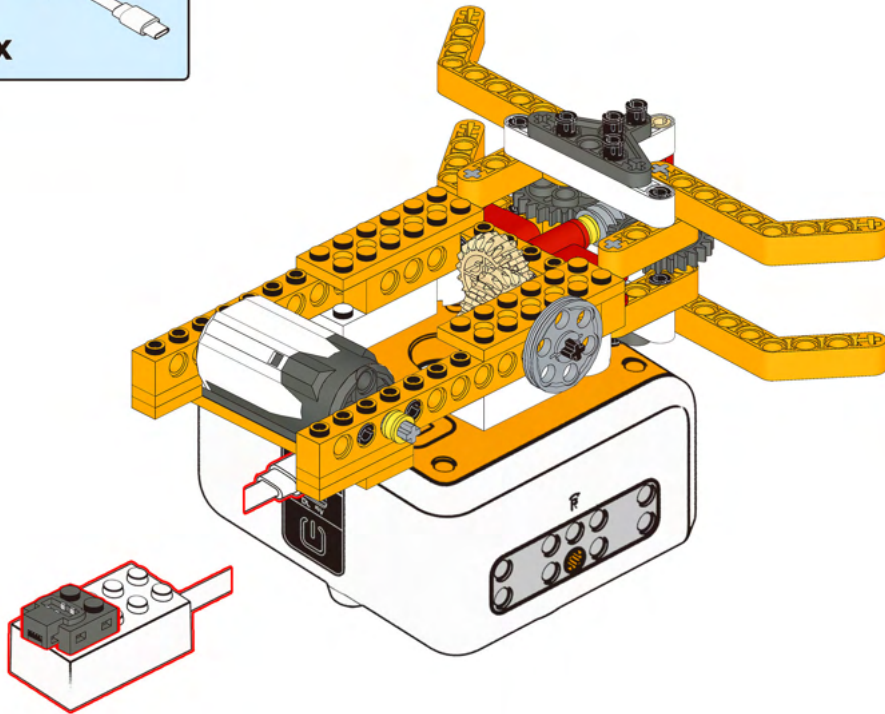

13

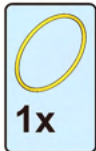

33

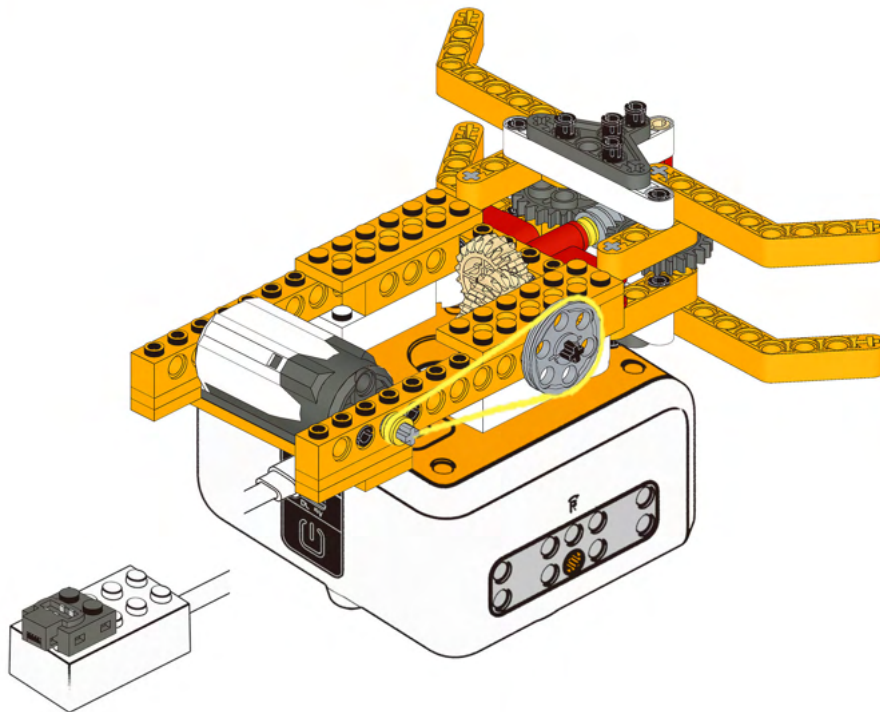

# Demo Program

```
when triangle key pressed
wait 1 seconds
move forward for 10 cm
set motor run clockwise with 100 % speed
wait 2 seconds
set motor run clockwise with 0 % speed
turn right for 90 degrees
move forward for 20 cm
turn right for 90 degrees
move forward for 10 cm
set motor run counterclockwise with 100 % speed
wait 2 seconds
set motor run clockwise with 0 % speed
```

The image shows a sequence of Scratch code blocks for a robot demo program. The blocks are as follows:

- when triangle key pressed
- wait 1 seconds
- move forward for 10 cm
- set motor run clockwise with 100 % speed
- wait 2 seconds
- set motor run clockwise with 0 % speed
- turn right for 90 degrees
- move forward for 20 cm
- turn right for 90 degrees
- move forward for 10 cm
- set motor run counterclockwise with 100 % speed
- wait 2 seconds
- set motor run clockwise with 0 % speed



## Case 4 Induction Door

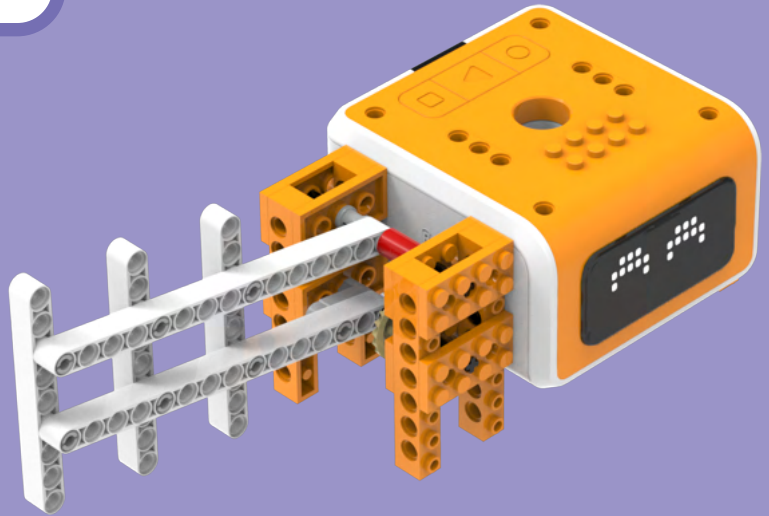

# Parts List

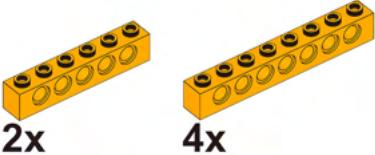
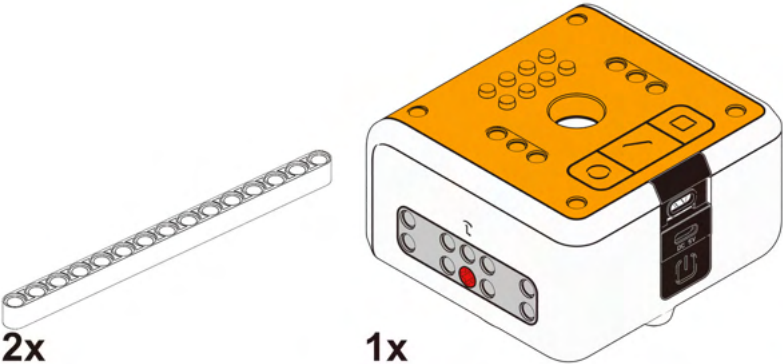



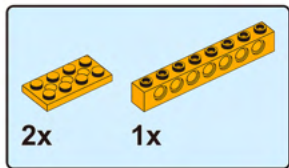

1

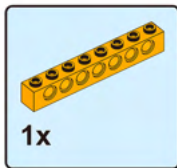
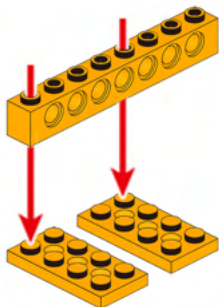

2

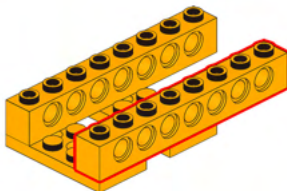

3

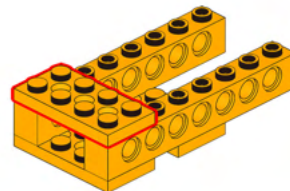

4

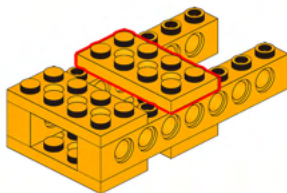

5

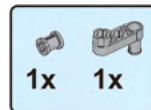
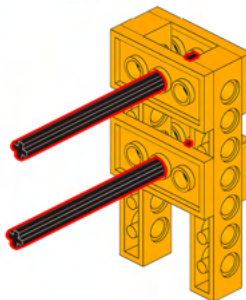

6

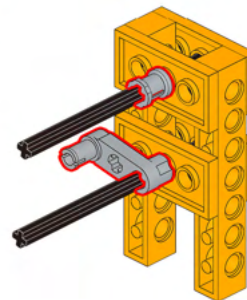

1

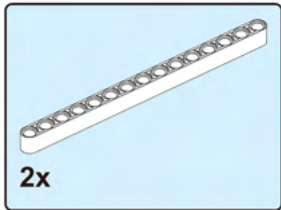

7

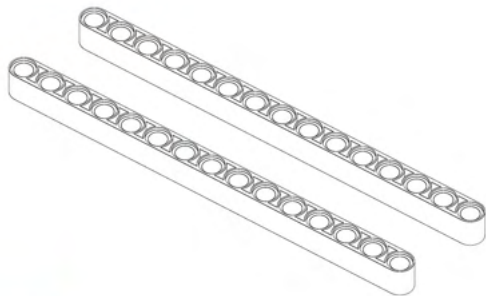

8

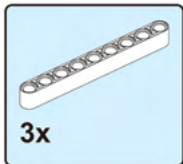
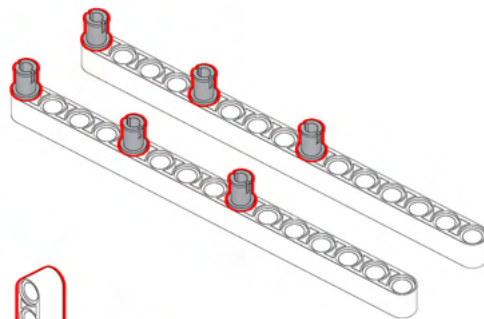

9

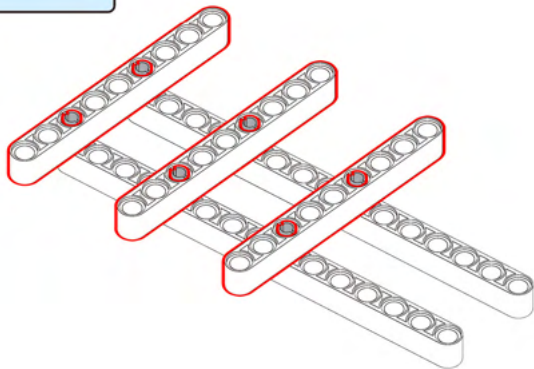

10

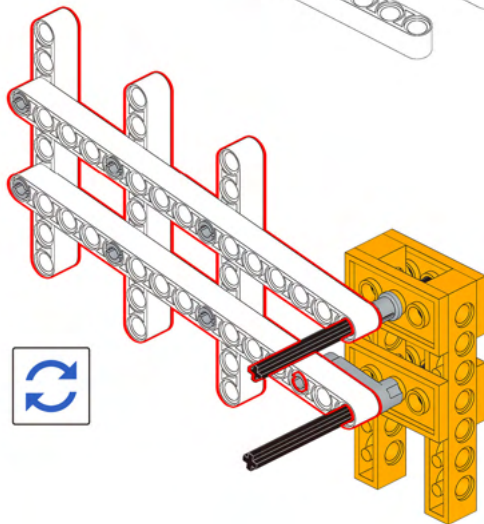

2

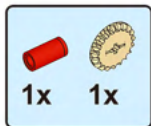

11

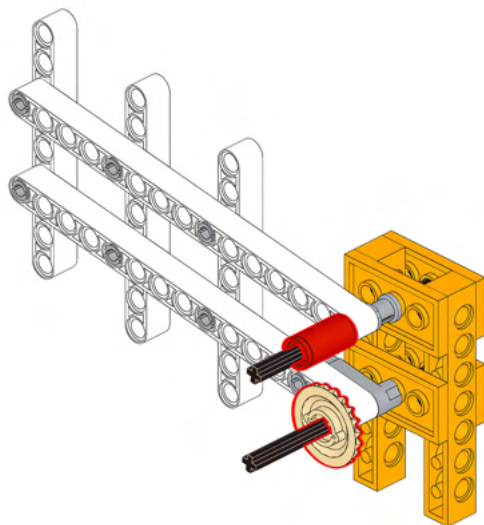

12

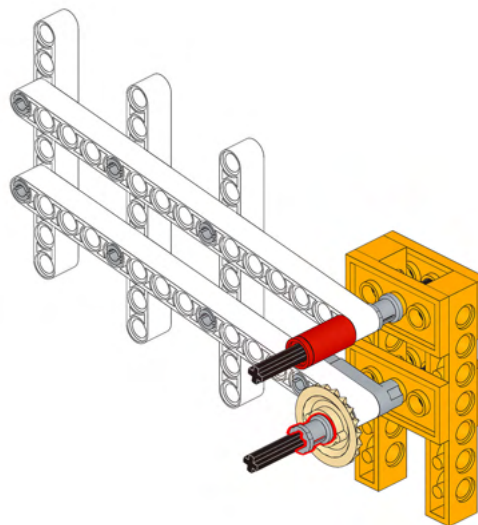

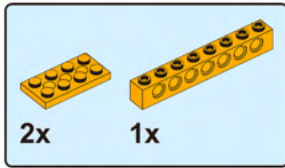

13

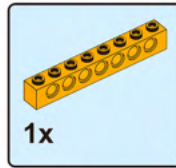
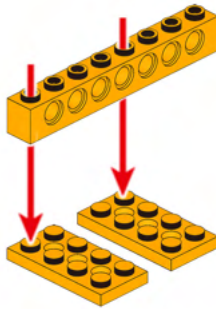

14

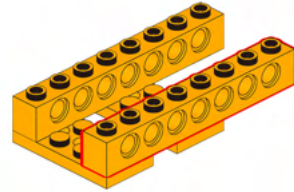

15

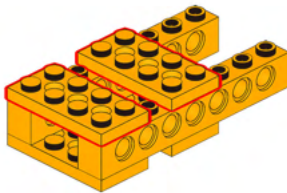

16

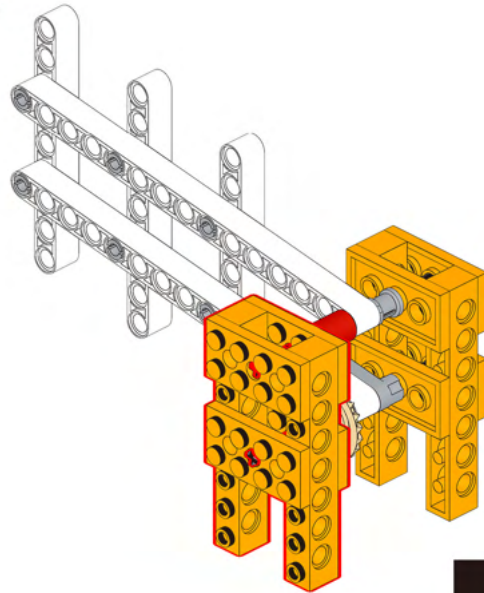



17

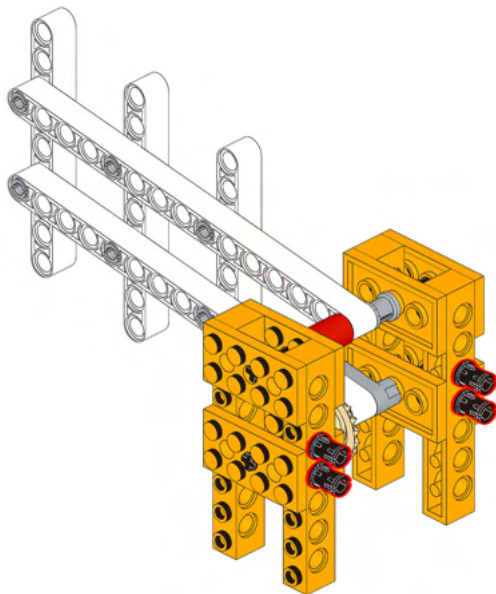

5

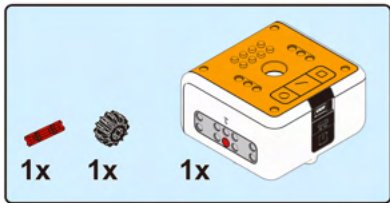

18

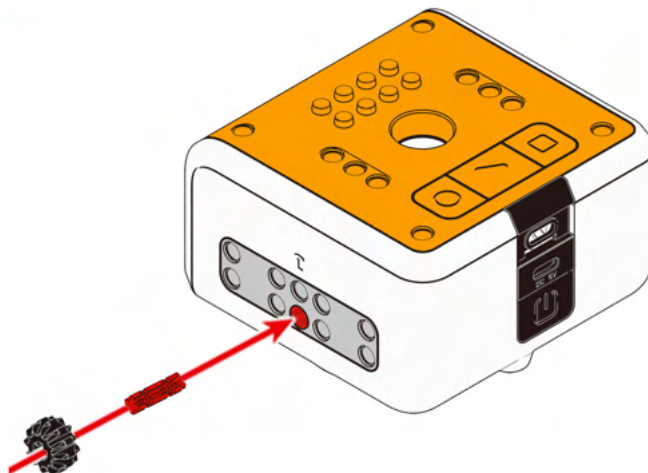

19

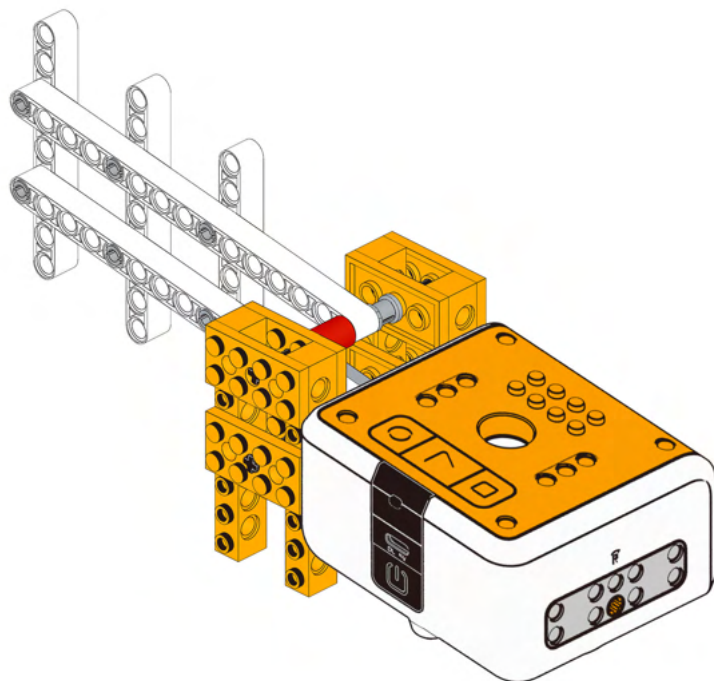

7





20

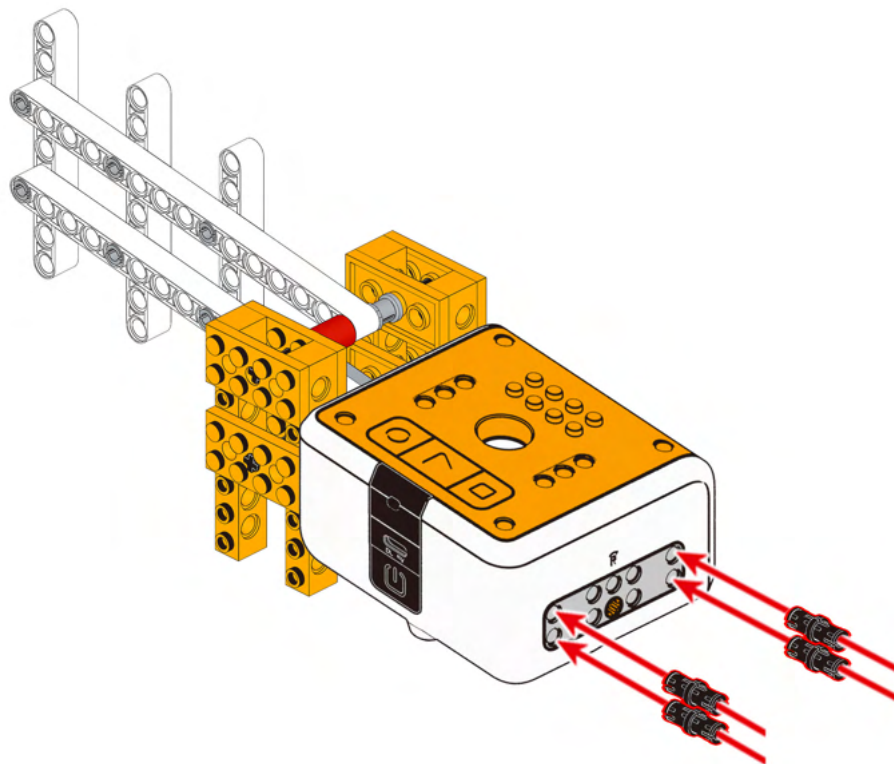

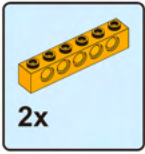

21

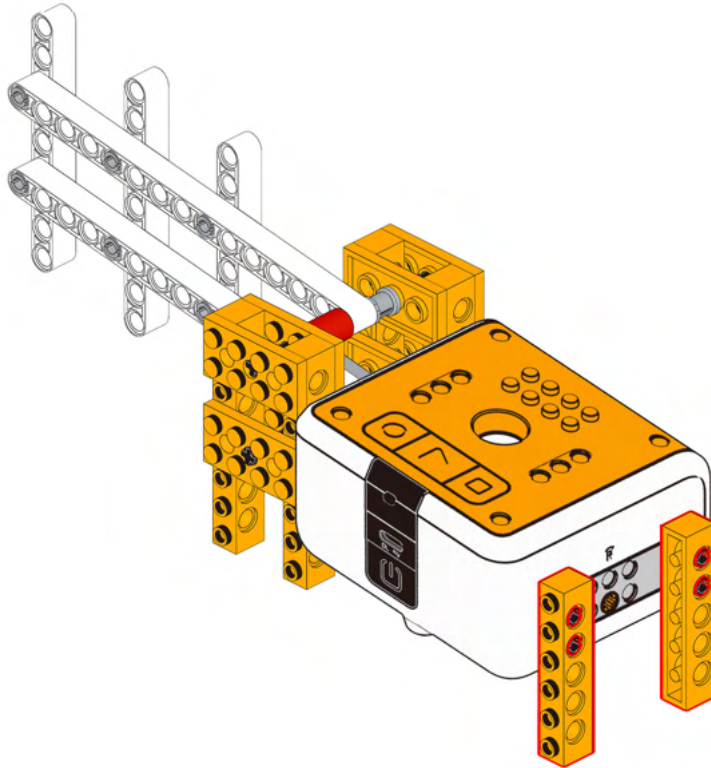

9

# Demo Program

```
when square key pressed
  L run 0.4 rotations with 100 % speed
```

```
when circular key pressed
  L run -0.4 rotations with 100 % speed
```

```
when obstacle distance < 20
  write hello
  L run 0.4 rotations with 100 % speed
  wait 3 seconds
  L run -0.4 rotations with 100 % speed
  show image [img alt="robot icon"]
```

## Case 5 Smart Fan

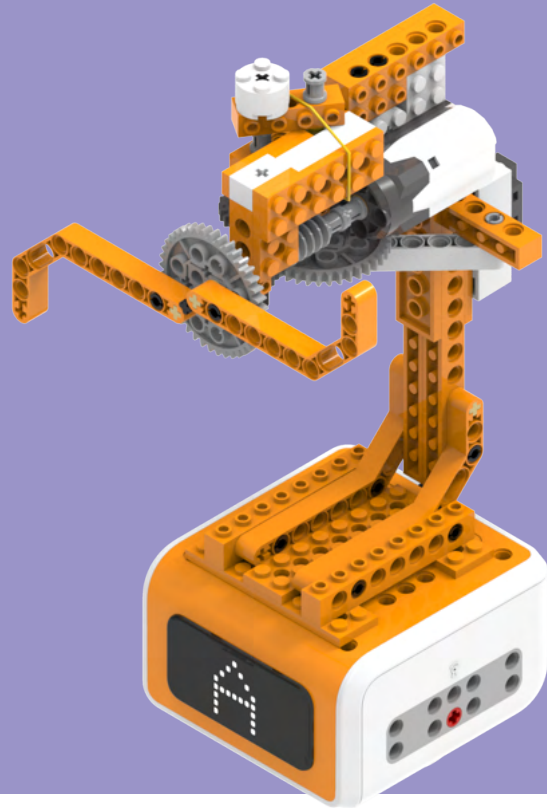

# Parts List

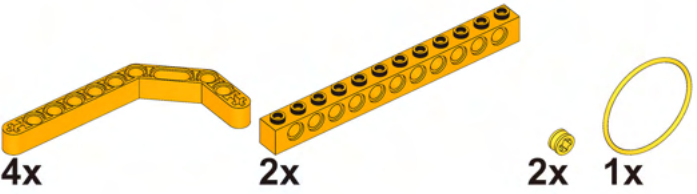
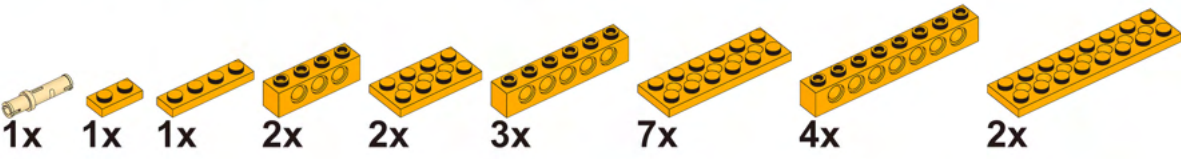
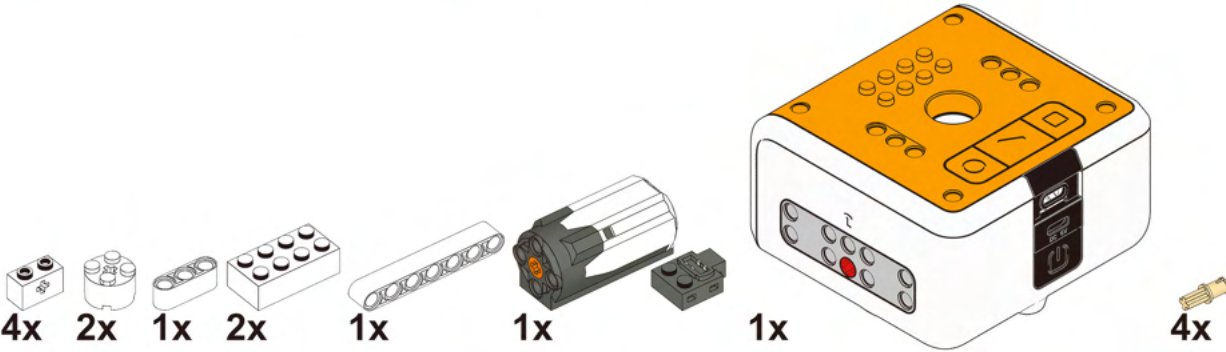
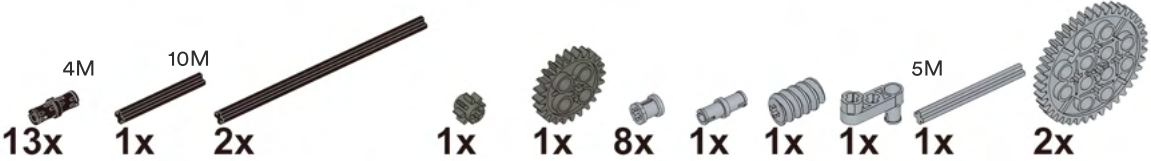

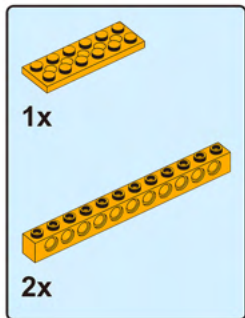

1

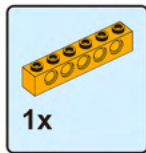
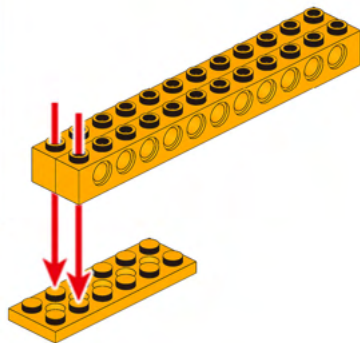

2

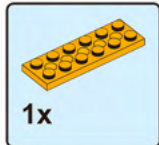
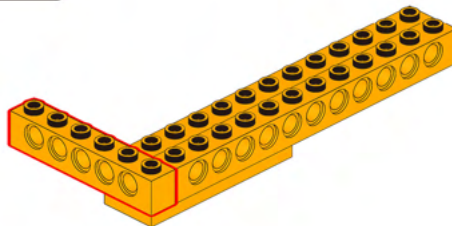

3

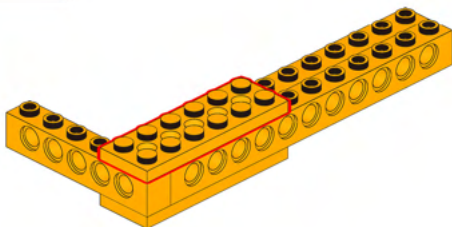

4

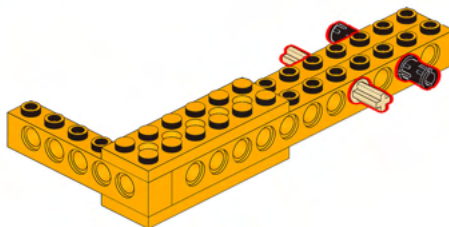

1

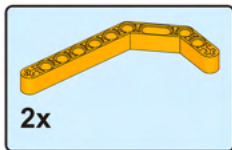

5



6

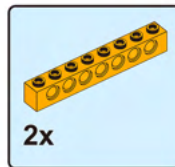

7

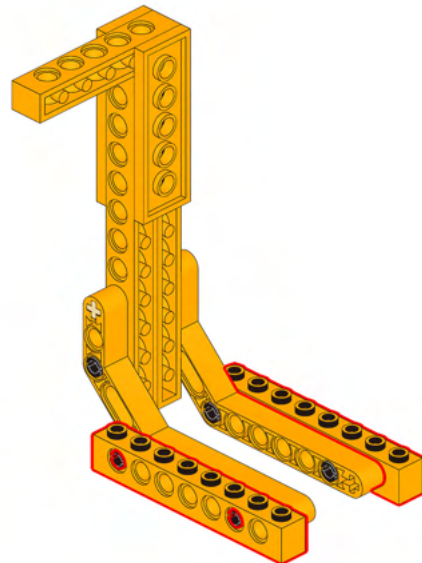
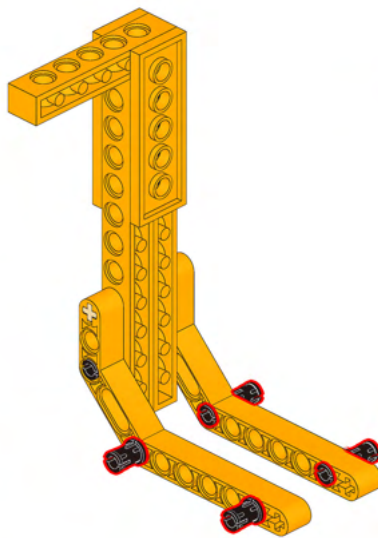
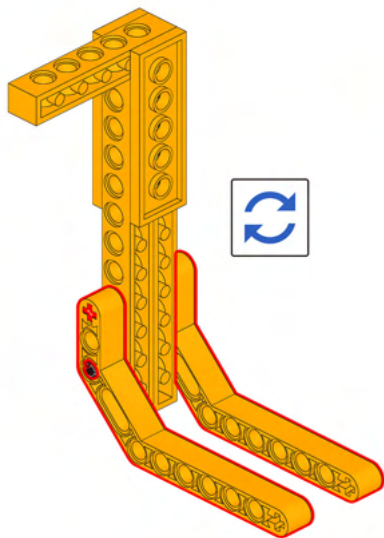



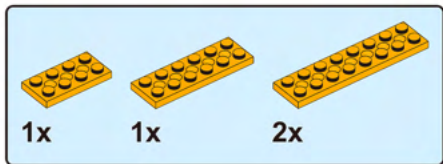

8

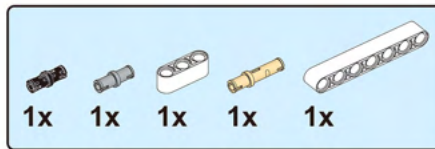
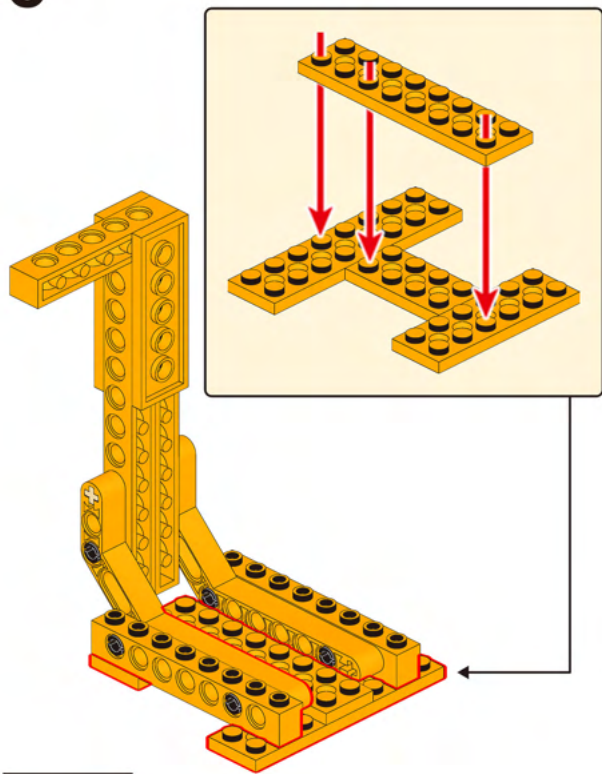

9

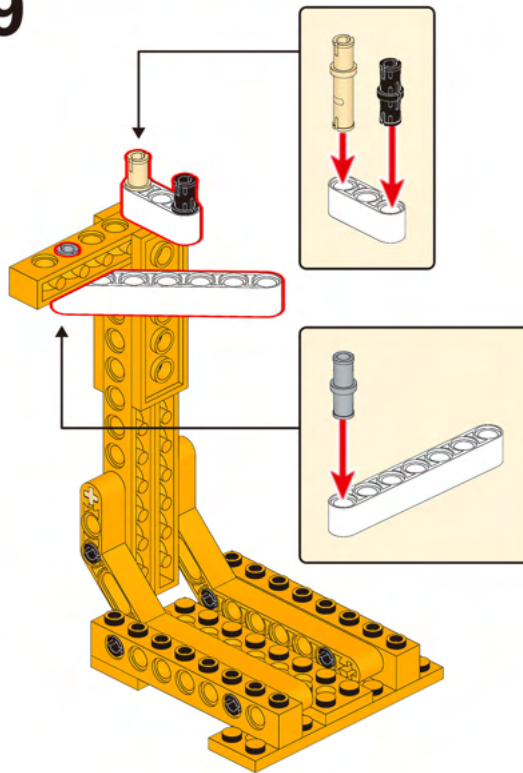

3

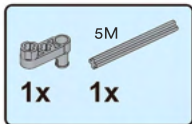

10

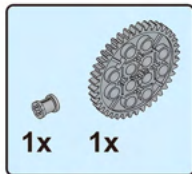
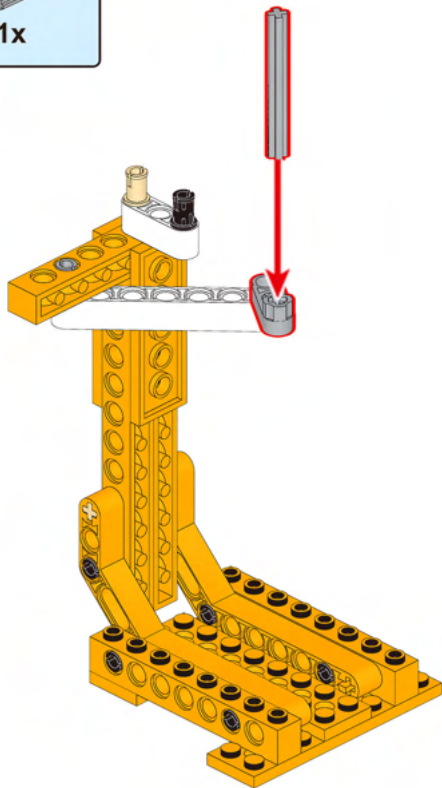

11

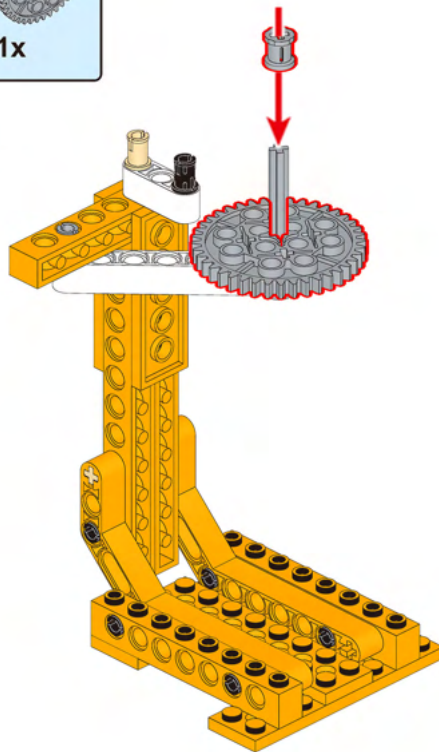

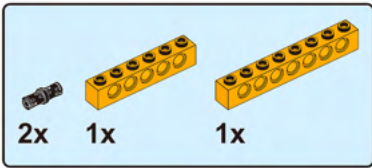

12

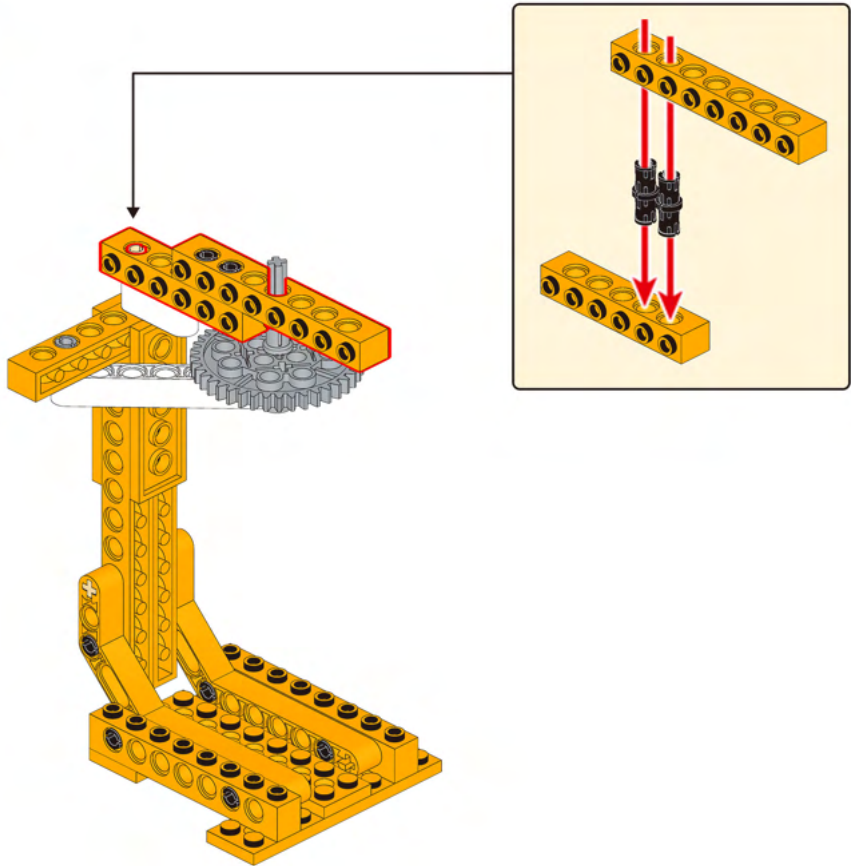



13

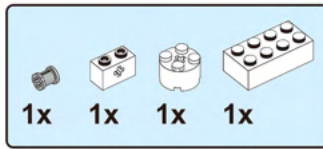
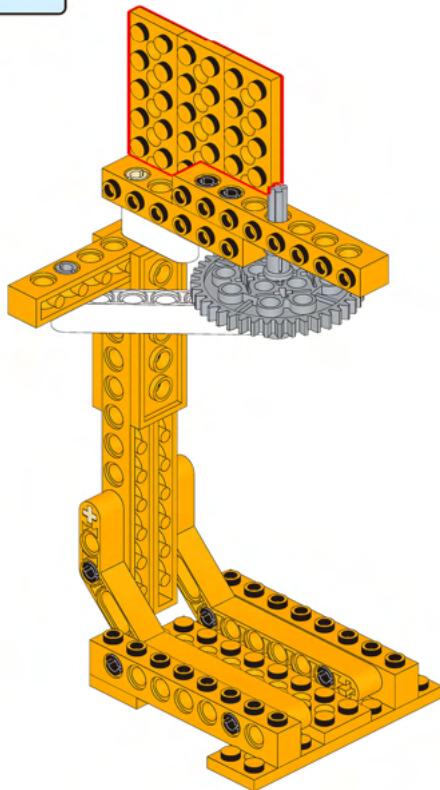

14

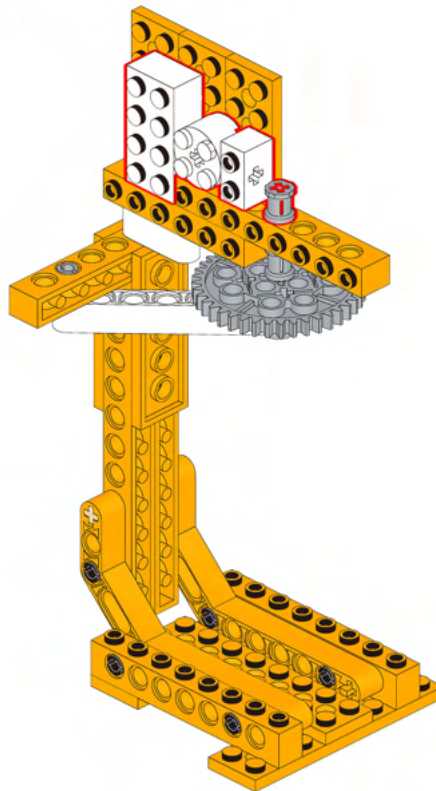

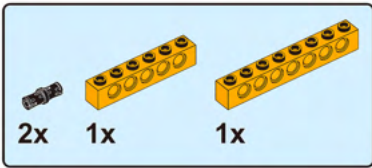

15

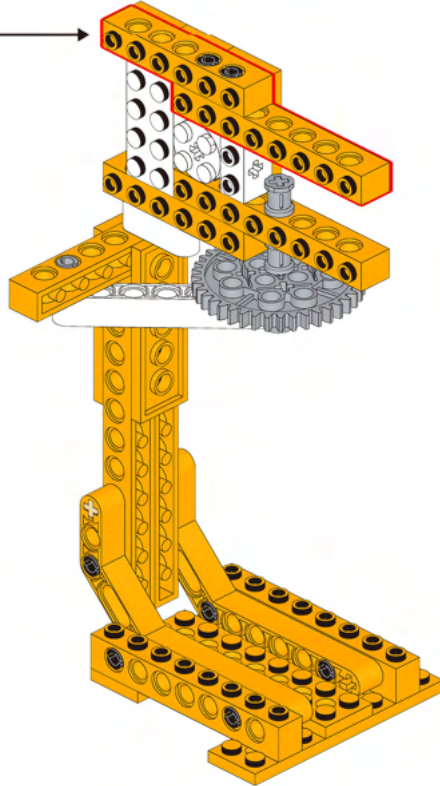
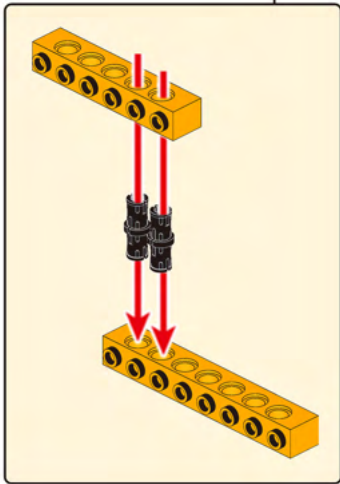



16

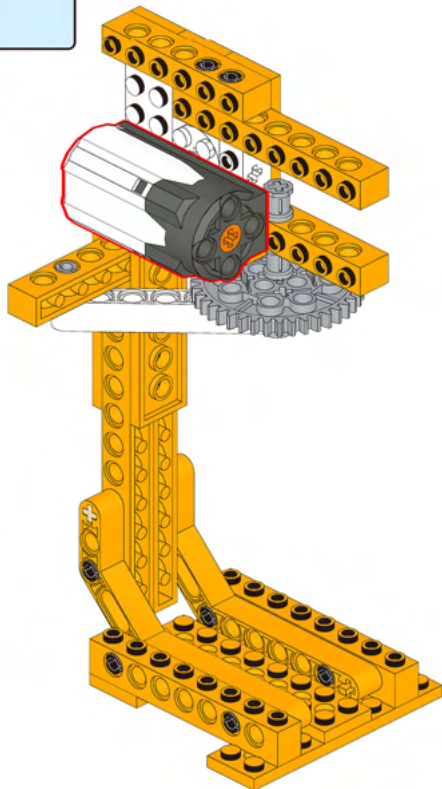

17

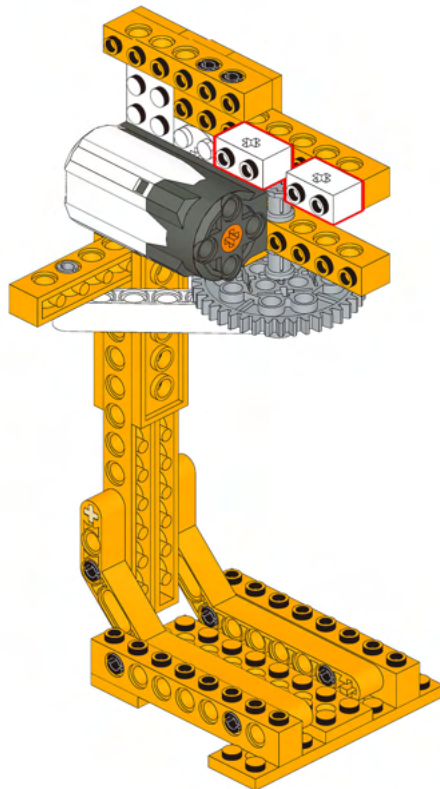



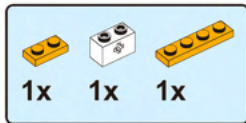

18

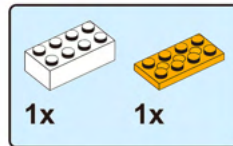
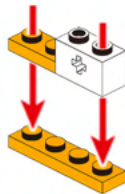

19

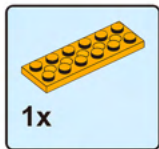
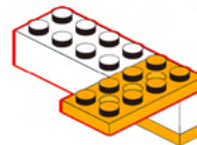

20

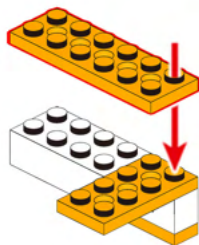

21

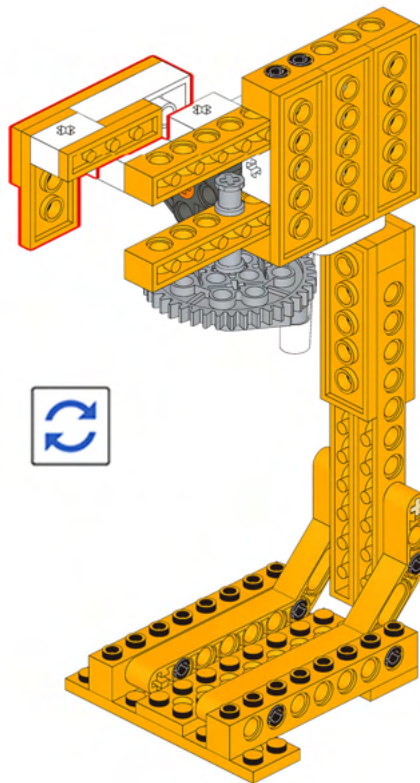



4M

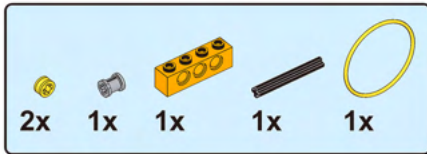

22

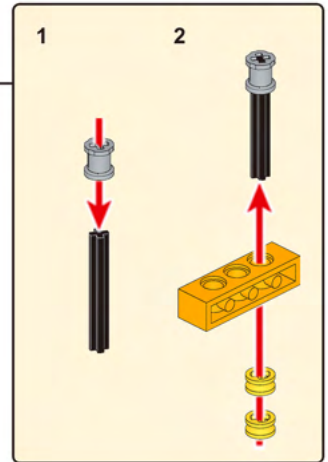
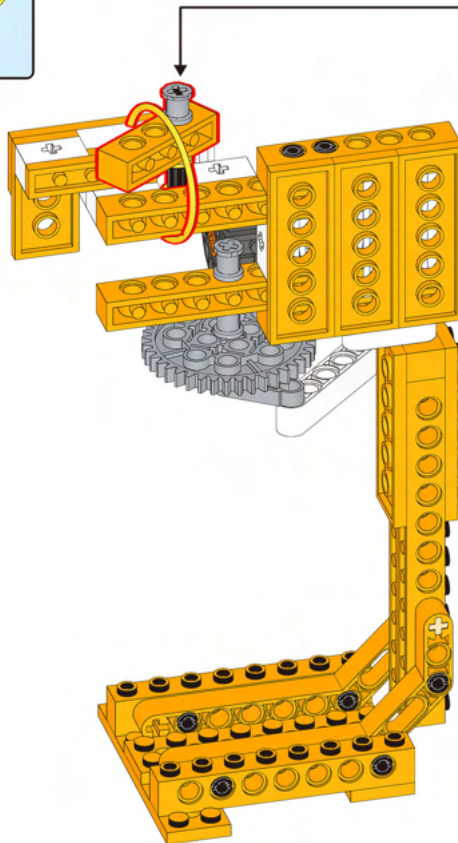

10M

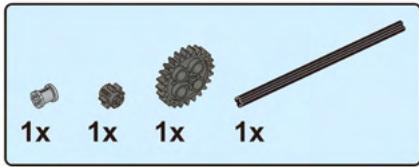

23

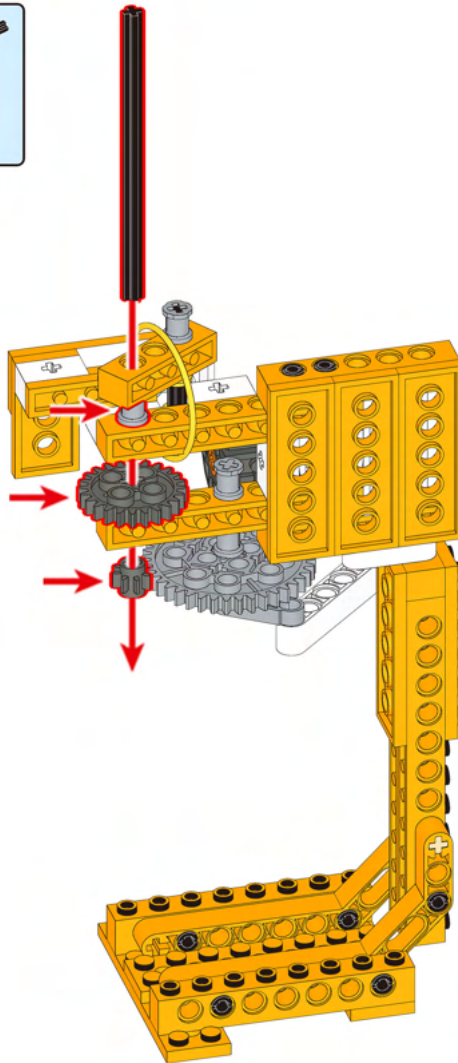

11



24

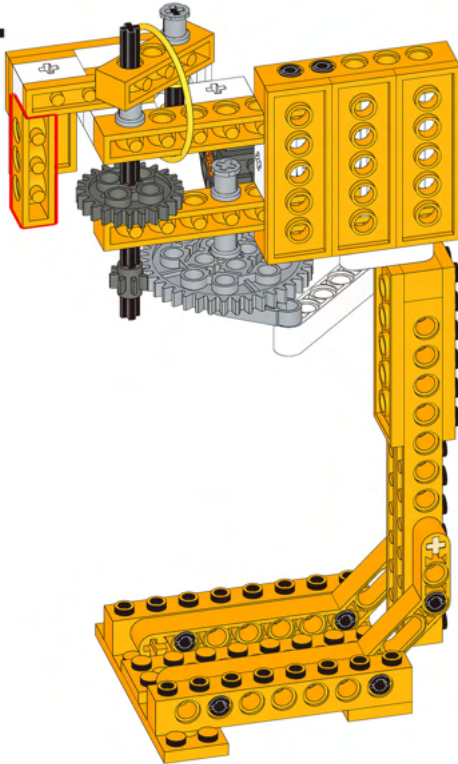

25

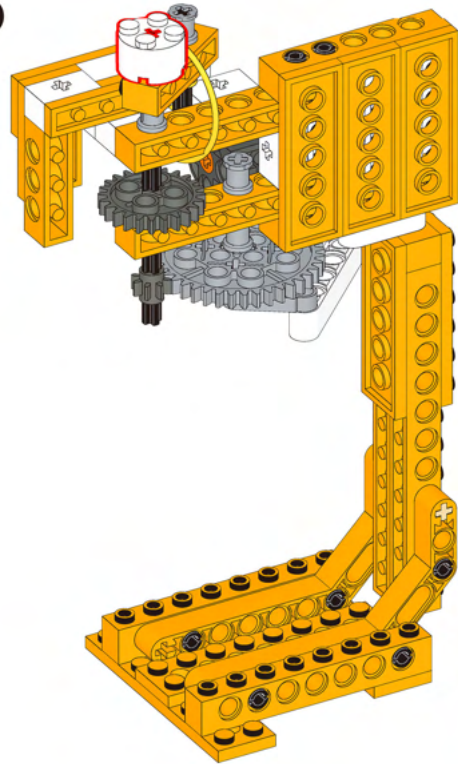

10M

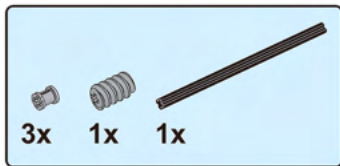

26

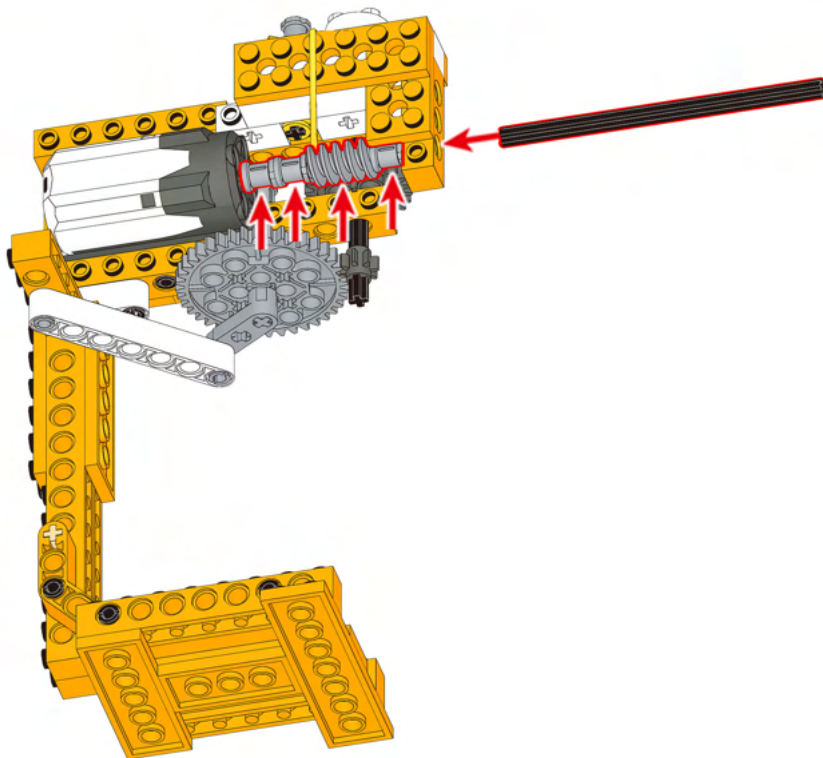

13



27

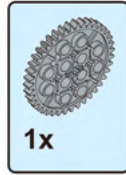
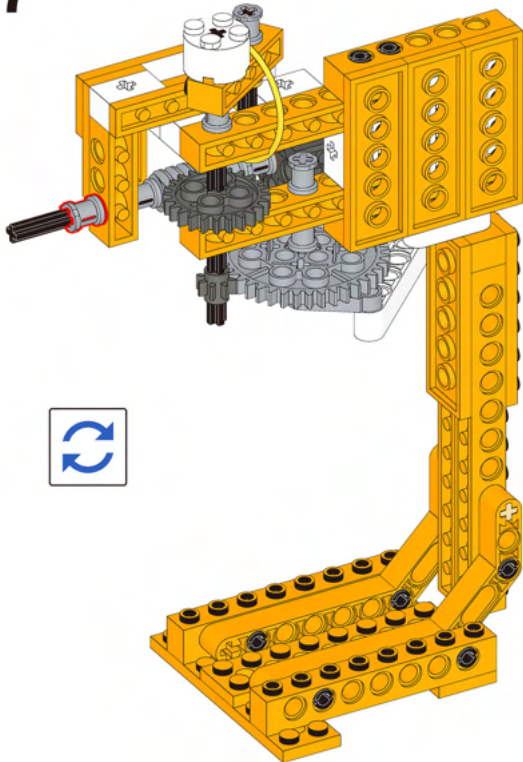

28

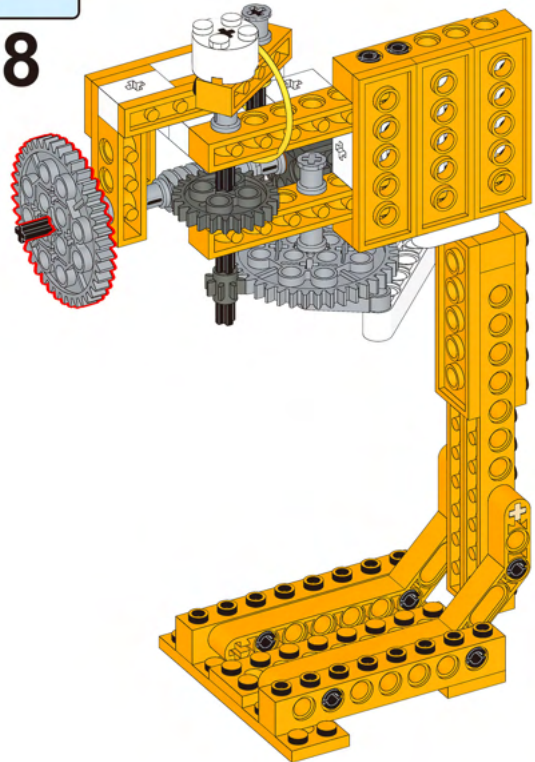



29

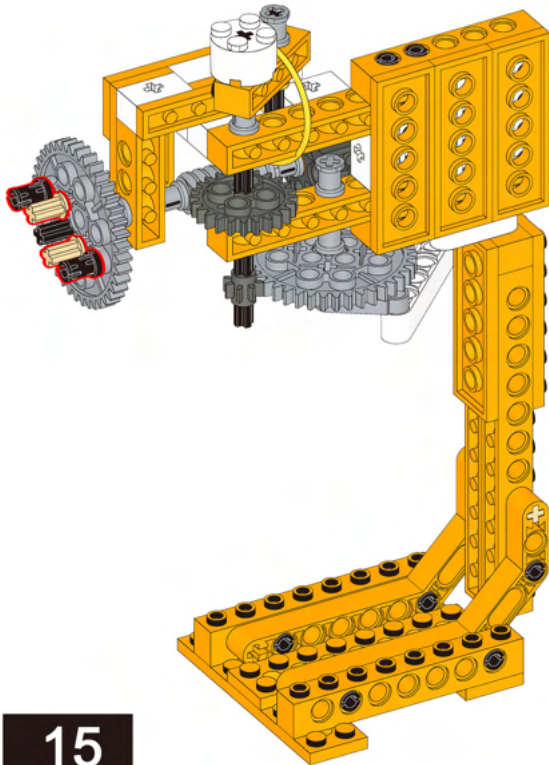

15

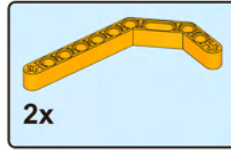

30

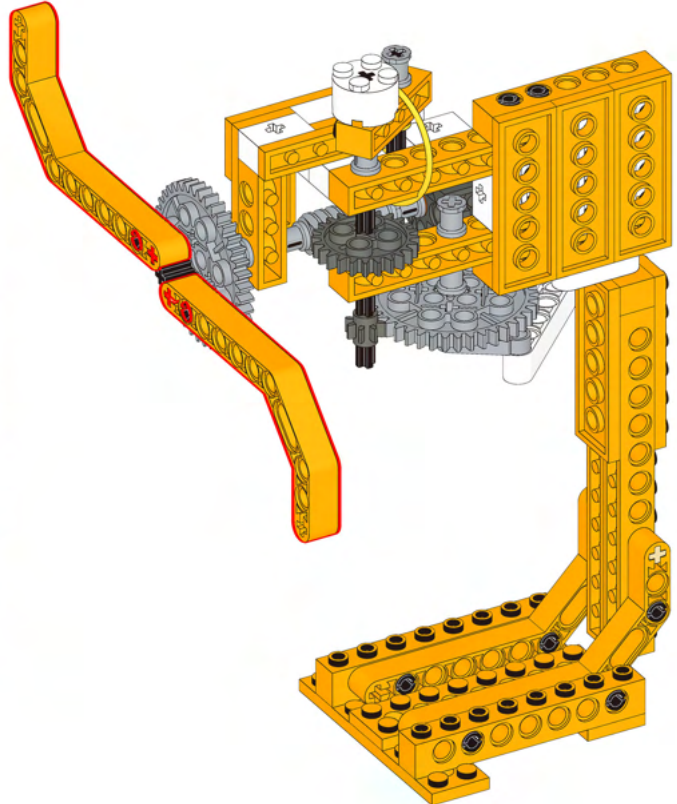



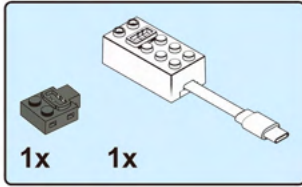

31

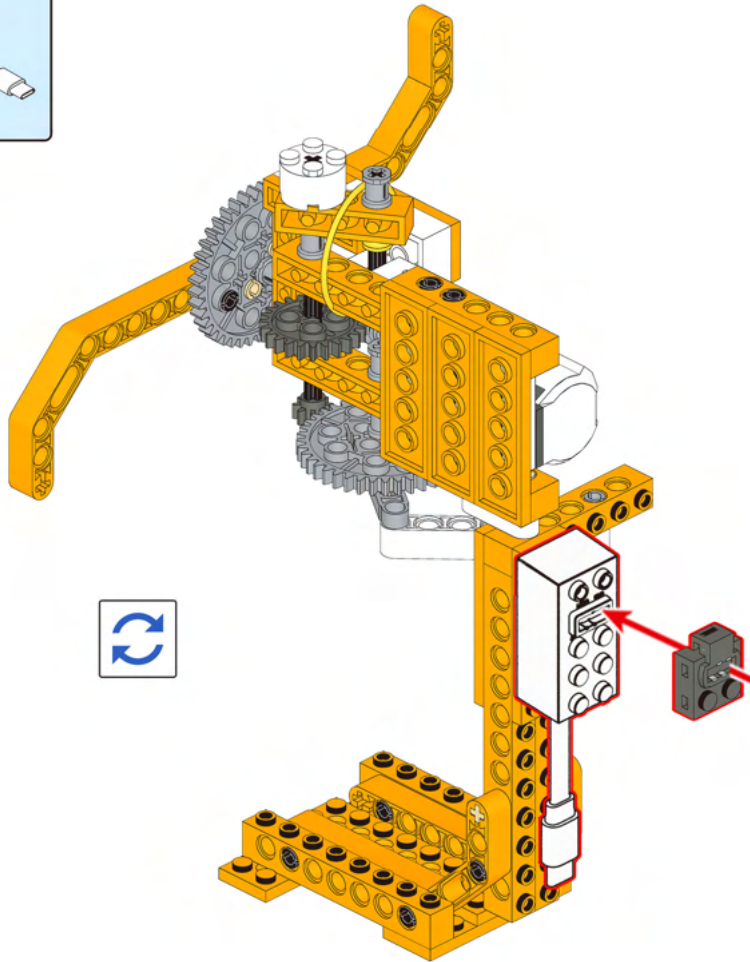



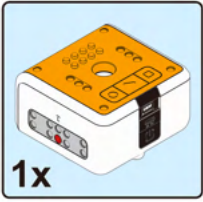

32

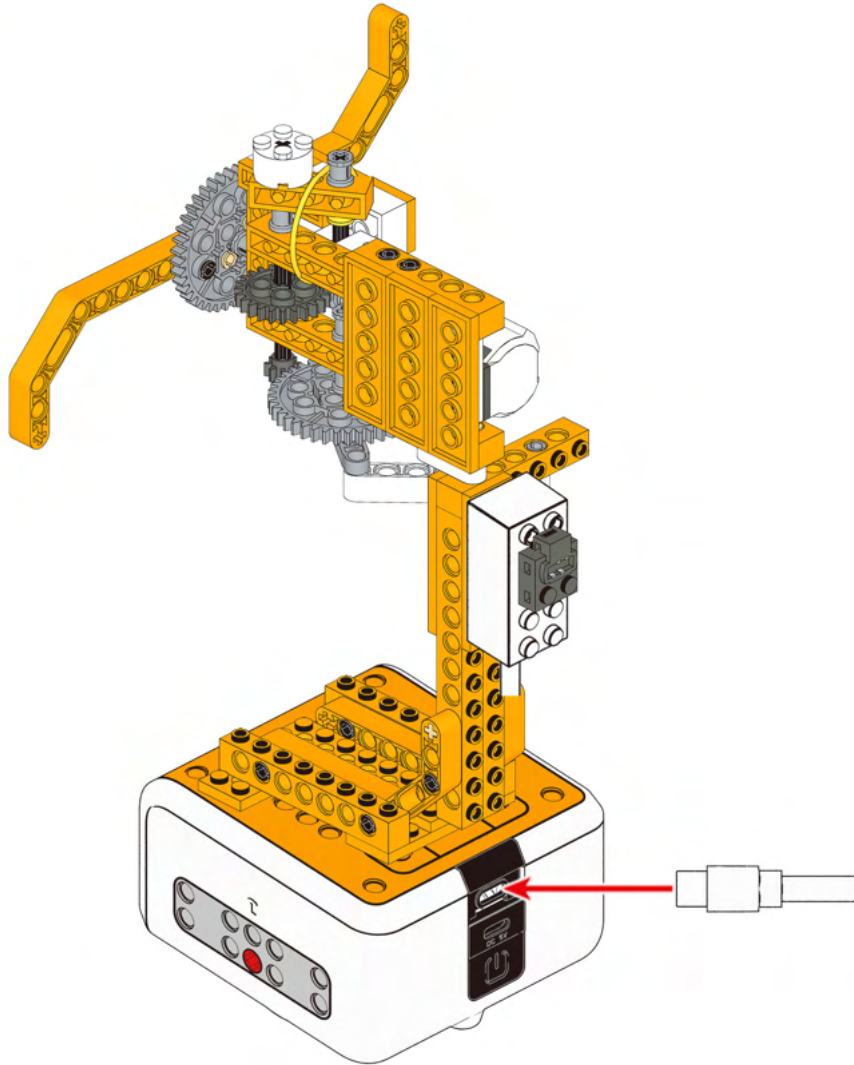

17

# Demo Program

```
when triangle key pressed
  forever loop
    if (ultrasonic sensor) is obstacle distance < 10 ? then
      set motor run clockwise with 100 % speed
      write C
    else
      if (ultrasonic sensor) is obstacle distance < 20 ? then
        set motor run clockwise with 85 % speed
        write B
      else
        if (ultrasonic sensor) is obstacle distance < 30 ? then
          set motor run clockwise with 70 % speed
          write A
        else
          if (ultrasonic sensor) is obstacle distance > 30 ? then
            set motor run clockwise with 0 % speed
            write 0
          else
            // empty else block
        end if
      end if
    end if
  end if
  wait 0.1 seconds
end forever
```

The code is a Scratch script starting with a 'when triangle key pressed' event. It enters a 'forever' loop. Inside the loop, there are four nested 'if' statements that check the 'ultrasonic sensor' for 'obstacle distance'. The conditions are: < 10, < 20, < 30, and > 30. Each condition is followed by a 'then' block containing a 'set motor run' block (clockwise, with a specific speed) and a 'write' block (with a specific character or number). The speeds are 100, 85, 70, and 0 respectively. The 'write' blocks output 'C', 'B', 'A', and '0'. There are also empty 'else' blocks for the < 20, < 30, and > 30 conditions. The loop ends with a 'wait 0.1 seconds' block.

## Case 6 Gyroscope Transmitter

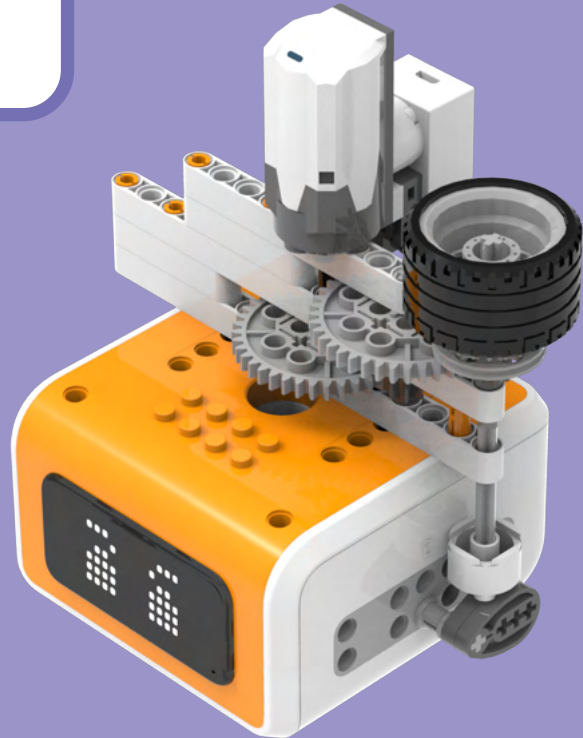

# Parts List

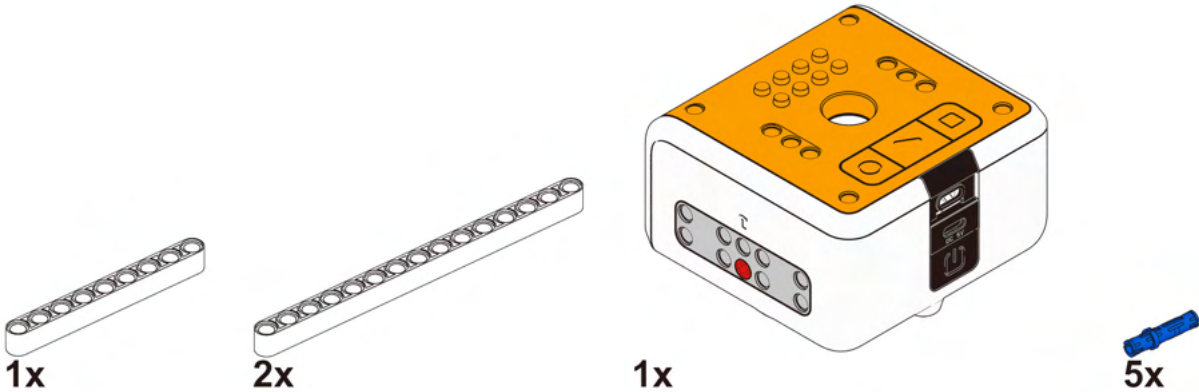
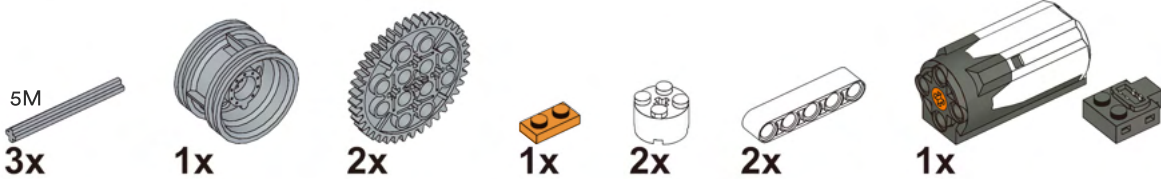

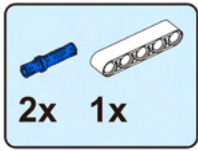

1

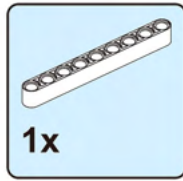
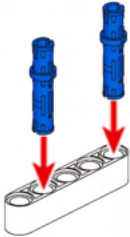

2

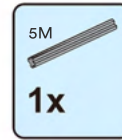
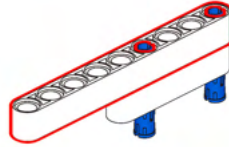

3

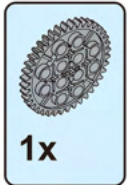
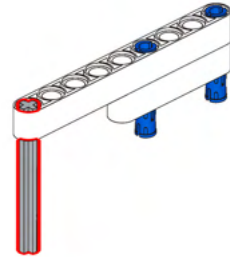

4

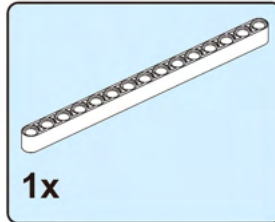
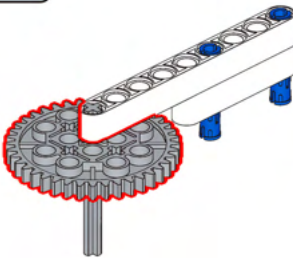

5

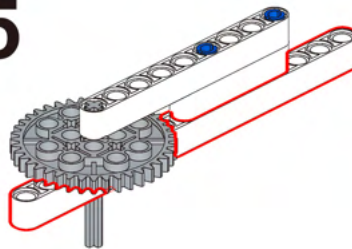

6

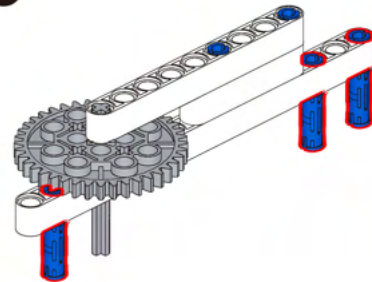

1

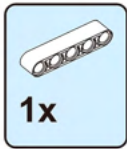

7

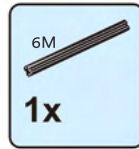
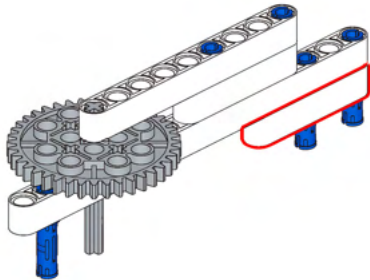

8

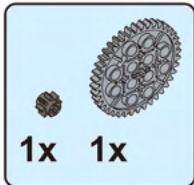
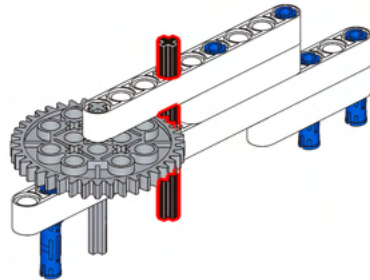

9

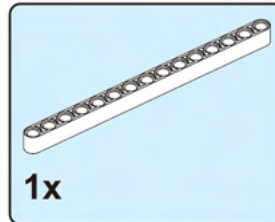
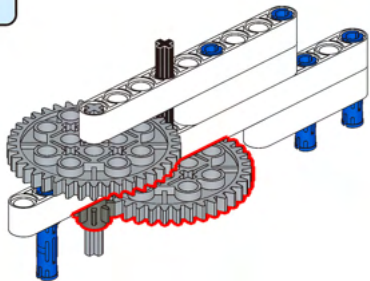

10

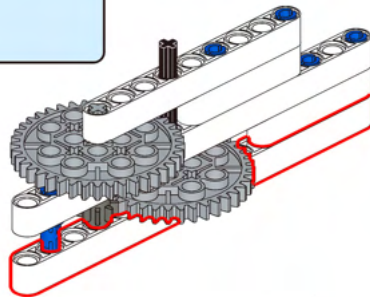



11

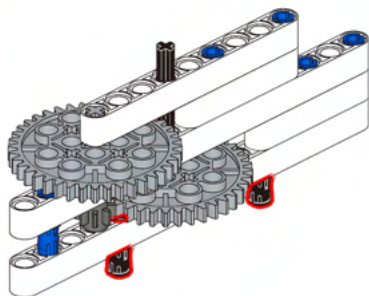

12

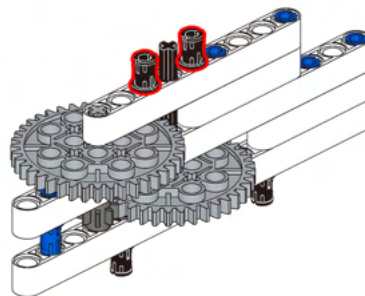

13

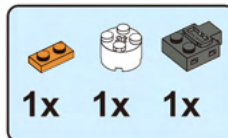
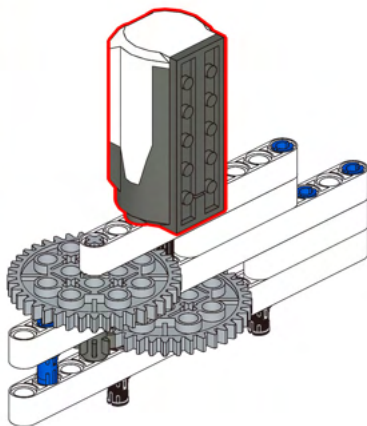

14

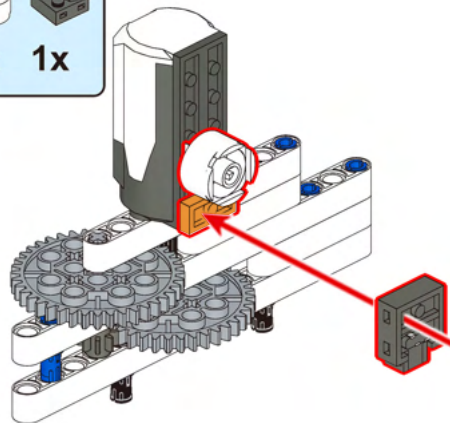

3



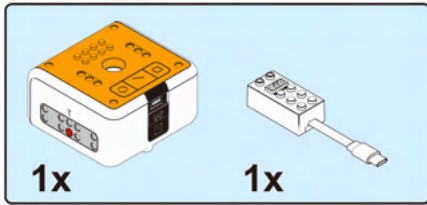

15

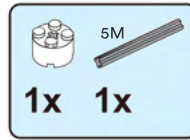
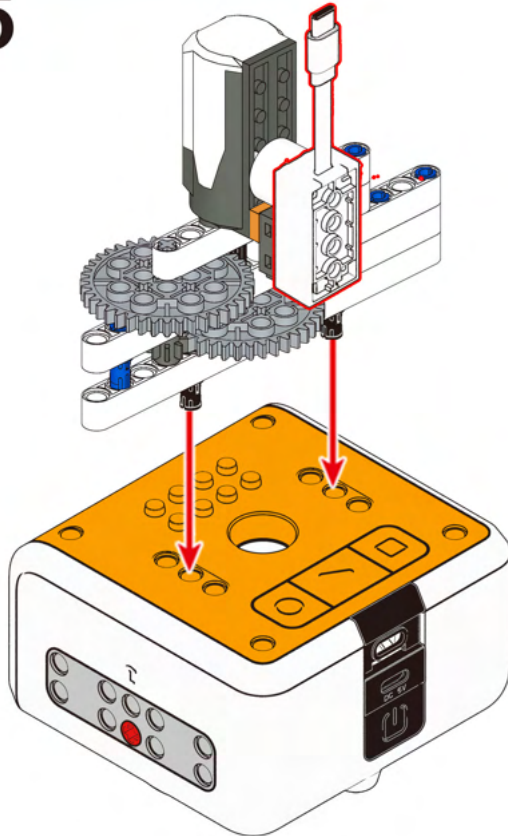

16

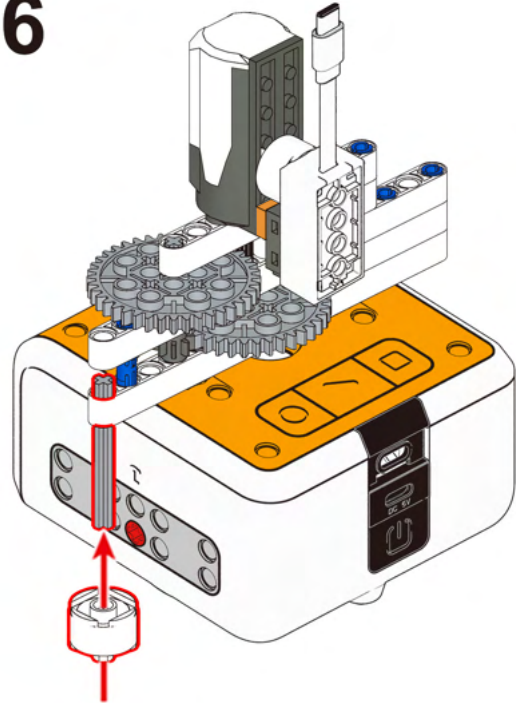

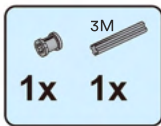

17



18



19



20

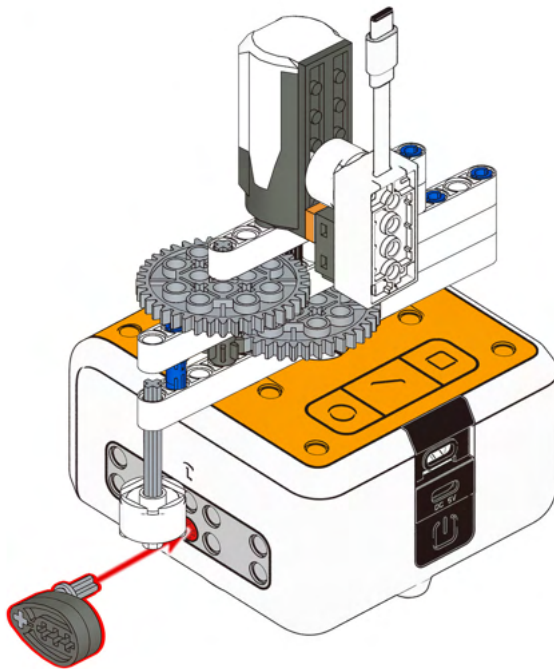



21



22



23

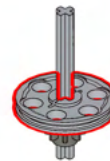

24

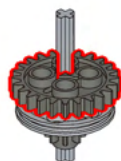

25

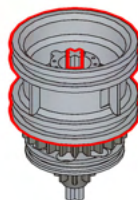

26



27

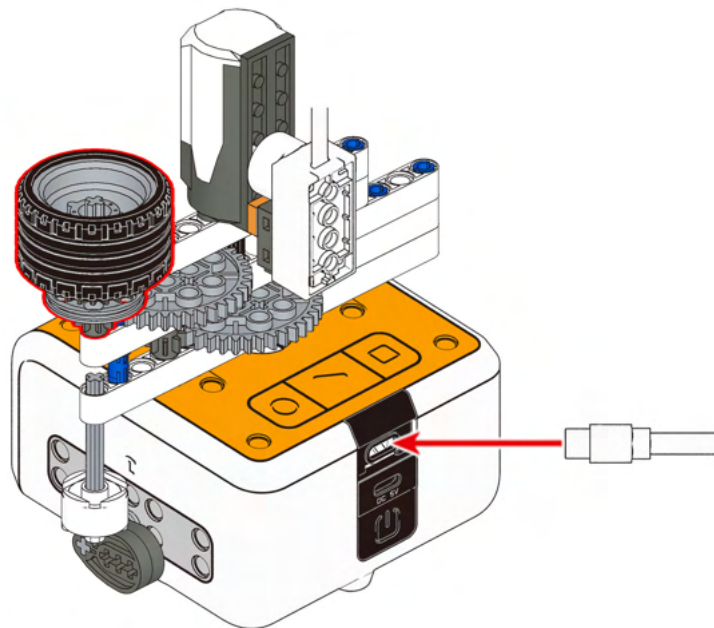

7

# Demo Program

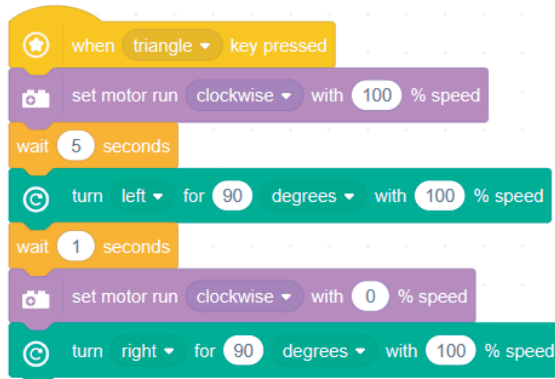







Designed by Matatalab in China  
MATATALAB CO., LTD.