



NON-SEGREGATED PHASE BUS

The Calvert Company

120 Aztec Drive
Richland, Mississippi 39218
Phone: (601) 939-9191

Emergency after hours: 866-688-2588

www.azz.com

AZZ | ELECTRICAL PRODUCTS GROUP

ATKINSON • BLENKHORN & SAWLE • CALVERT • CENTRAL ELECTRIC • CGIT SYSTEMS • N L I • R - A - L • S M S • W S I

CAL-000-0513

AZZ
LISTED
NYSE®



INNOVATIVE TECHNOLOGIES

PROVEN SOLUTIONS

AZZ | Calvert is a worldwide leader in the design and manufacturing of electrical bus systems since its inception in 1957. With bus system installations in a wide range of applications, and in more than fifty countries worldwide, Calvert has the knowledge and experience to provide a solution to meet your needs. Whether it's isolated phase bus, segregated phase bus, or non-segregated phase bus systems, let Calvert's 55+ years of experience work for you.

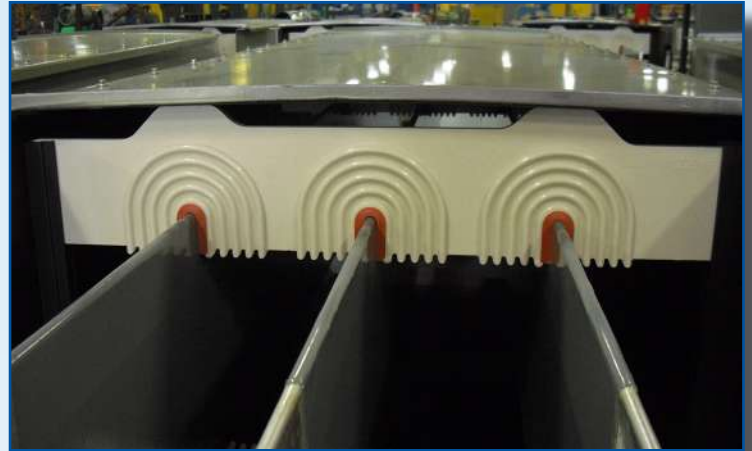

APPLICATIONS

AZZ | Calvert's bus systems are custom designed for a variety of applications and environments:

- Generator Main Bus
- Generator Excitation Bus
- Industrial Plants
- Refinery Plants
- Petrochemical Plants
- LNG Plants
- Substation Bus
- Distribution Bus

Regardless of your specific application, Calvert can provide you with a customized solution to meet your specific needs.

PRODUCT BENEFITS

Design and Installation: Calvert utilizes the latest computerized technology and automation processes to reduce cycle times. Calvert evaluates each project and provides bus sections in lengths that reduce the total number of sections, field splices and steel support structures to provide the lowest total installed cost possible.

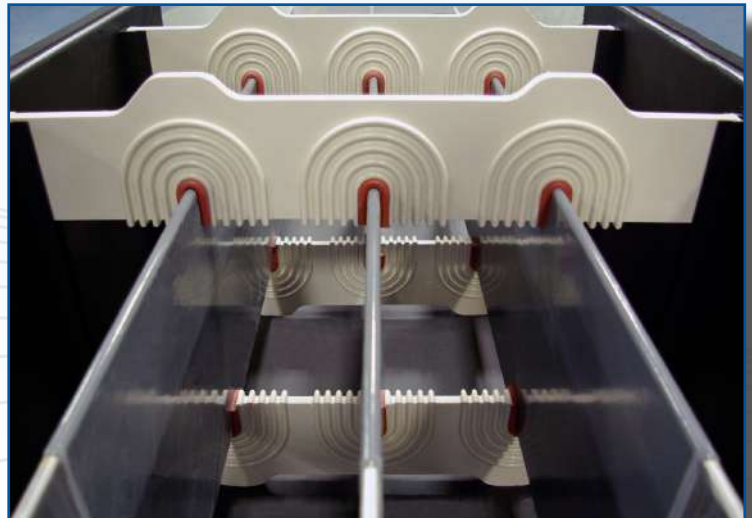

SUPERIOR RELIABILITY

Calvert's bus systems will provide long-term reliable service in the most demanding applications. Standard ratings range from 1200A to 5000A continuous current, and from 600V to 38kV nominal voltage class. Our standard designs incorporate epoxy coated bus bar conductors with high integrity cycloaliphatic epoxy support insulators to ensure long-term operation in tough environments. Our bar bus enclosure utilizes a unique formed housing that improves mechanical strength and minimizes the possibility of interior contamination. From power generation to industrial applications, Calvert's bus systems will provide years of reliable service; a hallmark of Calvert products since 1957. For further information or for ratings greater than 15kV, 5000 Amps, please contact our factory sales representatives.



Outdoor Bus System

CAPABILITIES

SYSTEM INTEGRATION

AZZ | Calvert supplies bus systems to connect equipment in any number of combinations including: switchgear to switchgear, switchgear to transformers, and generators to auxiliary compartments. As required, steel supports, fire rated barriers, bushing boxes, potential transformers and surge protection cubicles can be provided to complete the installation. Combined with complete installation and technical services, Calvert can provide a completely integrated system from design through installation and commissioning.

CAPABILITIES

- ISO 9001:2008 Certified
- Rugged Design for Long-Term Reliable Operation
- Low Total Installed Cost
- Complete System Design From the Ground Up
- State-of-the-Art Manufacturing Equipment
- Fluidized Bed Epoxy Insulation System
- Custom Engineered Designs
- Turnkey Projects From Initial Design
- Complete On-Site Service and Parts
- UL Labeled Equipment
- Certified to ANSI and IEC Standards
- Preventative Maintenance Program

Typical Non-Segregated Phase Bus Installation

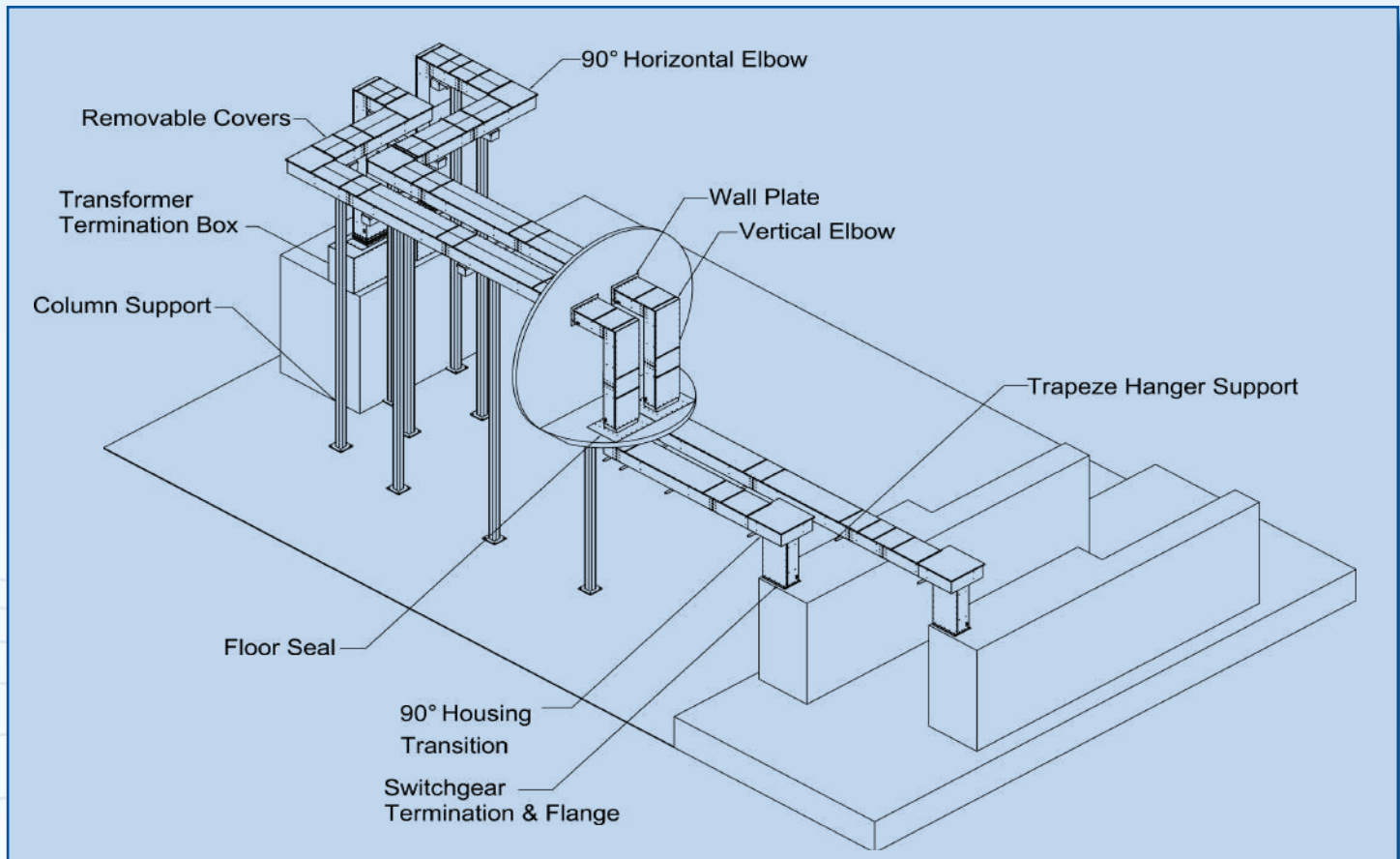

DESIGN & PRODUCT EXPERIENCE

SYSTEM DESIGN

AZZ | Calvert's bus system design has been engineered to provide optimum performance at the lowest total installed cost. With over 55 years of industry experience and the latest materials and manufacturing techniques, Calvert's non-segregated phase bus systems provide a long lasting and reliable system unmatched in the industry. By simplifying the design to reduce the total number of components, Calvert has improved the reliability while decreasing total installed costs and lead times. Certified to meet the requirements of ANSI/IEEE C37.23 and IEC Standards, Calvert can provide non-segregated phase bus systems for worldwide applications. Combined with dedicated service personnel and complete installation, Calvert can supply reliable total solutions.

PRODUCT DESCRIPTION

Calvert's standard design is a Totally Enclosed, NEMA 3R class bus system. Non-segregated and segregated phase bus designs can be provided. Standard service ratings are 600V, 5kV and 15kV, from 1200A to 5000A. Extensive testing has been performed to demonstrate full compliance with ANSI/IEEE C37.23, and IEC. Each system is specifically designed for actual site environmental conditions such as ambient temperature, solar gain, elevation and seismic conditions. All Calvert bus systems can be configured for 3-phase 3-wire, 3-phase 4-wire (half or full neutral), or 2-phase DC service, with an internal or external mounted ground bar.



FEATURES & BENEFITS

CONDUCTORS

All Calvert bar bus systems are rated for continuous operation at specified current without exceeding a temperature rise of 65° C based on a 40° C ambient temperature. Each application accounts for solar radiation, ambient temperature ranges, and site elevation. The bus bars are fabricated from CDA 110 grade copper with conductivity in excess of 99%. Aluminum conductors can also be supplied depending on the application. Standard insulation for all applications above 600V is fluidized bed epoxy. For applications below 600V, bare conductors are supplied with a high temperature flat black finish installed on fiberglass block assemblies.



TERMINATIONS

Terminations are custom designed and manufactured to match customer equipment exactly. Coordination is done with the customer to ensure proper fit and function when installed in the field. Expansion joints, utilizing ropelay flexes and flexible bellows, are available to allow isolation from vibration or to accommodate seismic conditions at the site.



Switchgear terminations are bar to bar design. In either case, all contact surfaces are silver-plated and utilize pre-set stainless steel conical washers to insure the proper clamping force for a reliable operation. Termination connections can be supplied with custom molded boots if required.

CONDUCTOR SUPPORT BLOCKS

Conductor support blocks can be cycloaliphatic epoxy insulators or molded fiberglass polyester. Both provide excellent tracking and are flame and water resistant. The conductor bus bars are cradled in an elastomeric rubber that cushions the bus bars from mechanical vibrations forces resulting from high current faults. The rubber also eliminates partial discharge activity (corona) that is associated with air gaps between insulation components.

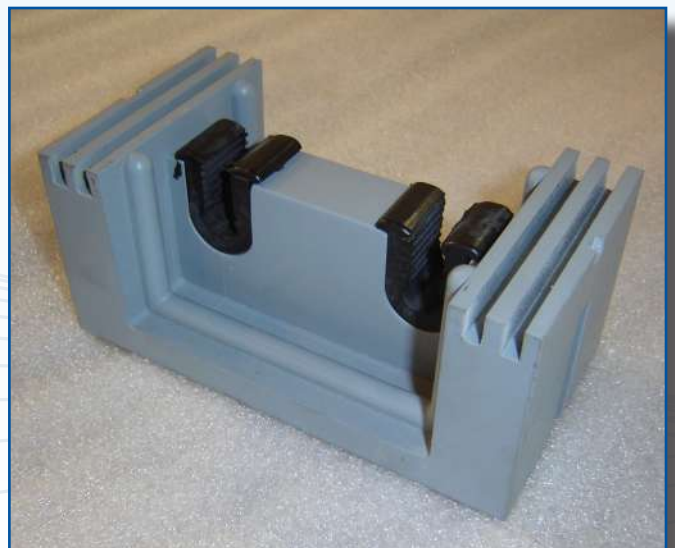

CONDUCTOR DESIGN

All conductor bus bars are fabricated from 110 grade copper that exceed 99% conductivity. Bus section conductors are networked directly to CNC machines that produce conductors to our exact standards.

ENCLOSURE CONSTRUCTION

Standard enclosures are fabricated from corrosion resistant high strength aluminum alloys. Bus designs are networked directly to CNC machines that produce enclosures precisely and automatically. Unlike steel enclosures, aluminum enclosures reduce total weight and prevent heating of the enclosure due to hysteresis losses.

All enclosures are supplied with fully removable top covers, removable bottom covers at all splice joints, and any other location that requires access from underneath. The covers are fastened with self-drilling Tek Screws with an aluminized finish that protects against dissimilar metals. The fasteners also have special heads that embed into the cover material when tightened to ensure electrical bonding between the side members and covers. The covers are sealed with high quality gasket material to protect the system in the most demanding environments.

All enclosures are supplied with factory installed silver plated copper ground pads at each termination point of the bus duct system. The enclosure is designed to carry the required fault current in all applications. Calvert can supply an internally mounted continuous length ground bar for additional protection, if required. Customized enclosures can be provided including stainless steel and ventilated enclosures depending on the application.

CONDENSATION CONTROL

Standard condensation control consists of 240V, 500W heaters operated at 120V to increase heater life, adjustable thermostats and filtered breathers. All heaters are mounted internal to the bus enclosure. Circuits requiring more than twelve heaters are supplied with a step down transformer, relays and are designed to operate from a 480V or 240V supply to reduce power consumption. Heaters and circuits are factory wired to an external junction box for connection to power supply. Each shipping section of bus duct comes factory pre-wired to an internally mounted terminal block for easy field assembly.



DETAILED SPECIFICATIONS

Enclosures Standard NEMA 3R rated enclosures are fabricated from highly corrosion-resistant and high conductivity aluminum alloy 1100-H14. Enclosures are formed from 0.125 inch (3mm) thick material. Top covers are 0.09 inch (2.3mm) thick and peaked for outdoor applications. Stainless steel 304 or 316 enclosures can be provided if specified. Calvert's standard finish color is ANSI 61. Special colors can be provided upon request.

STEEL SUPPORT STRUCTURES

Standard steel supports are designed to specific site requirements. Support design drawings show details of the support structure, anchor bolts and foundation load requirements. All support structures are hot dipped galvanized. Depending on environmental conditions, support spacing can be up to 16 feet (4.9 meters).

ACCESSORIES

Wall penetrations, bus end seals, bushing boxes for open air connections, 2 hour and 3 hour rated firestops, expansion joints, earthquake joints, misalignment joints, vibration joints, special support structures, special bus finishes and many other options can be supplied as required.



BAR FABRICATION & EPOXY COATING

CONDUCTOR INSULATION

All conductor bus bars are insulated with our epoxy fluidized bed process. The fluidized bed process utilizes superior insulating properties. After insulation is applied, each bar is individually tested for dielectric integrity. All conductor splice joints are supplied with removable insulating boots for easy installation and maintenance.



Bar Fabrication



Epoxy Coating System



Epoxy Coating System



Finished Product

DESIGN DETAILS

Figure 1

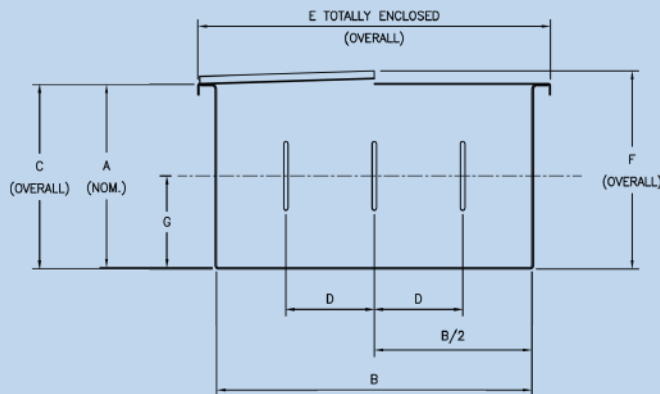
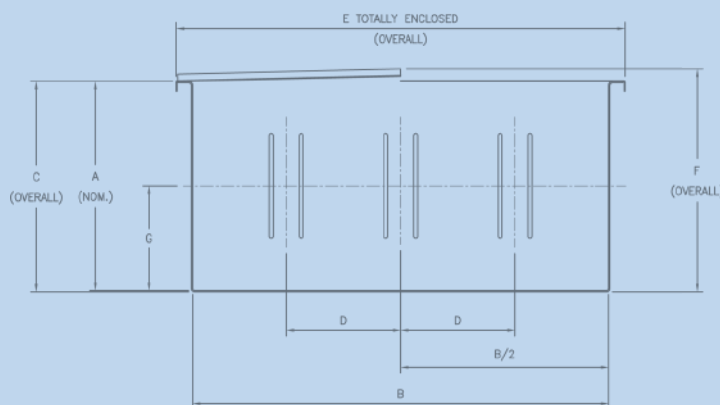

Figure 2



Non-Segregated Phase Bus Systems Technical Data

600V SYSTEMS (NON-INSULATED) COPPER CONDUCTORS

Amp Ratings	Figure	Weight (Lbs. per Foot)	Resistance (Micro-ohms per Foot)	Losses (Watts per Foot)	Reactance (Micro-ohms per Foot)	Impedance (Micro-ohms per Foot)	Typical Systems Dimensions - Inches						
							A	B	C	D	E	F	G
1200A	1	32.85	7.6948	33.24	53.49	54.04	16.00	27.00	16.125	7.5	30.063	16.812	8
1600A	1	32.85	8.1302	62.44	53.49	54.10	16.00	27.00	16.125	7.5	30.063	16.812	8
2000A	1	32.85	8.6627	103.95	53.49	54.18	16.00	27.00	16.125	7.5	30.063	16.812	8
3000A	1	50.02	3.5935	129.04	53.49	54.10	16.00	27.00	16.125	7.5	30.063	16.812	8
4000A	2	65.94	3.7805	181.47	53.49	54.10	20.00	40.00	20.125	12.0	43.063	20.812	10
5000A	2	89.12	1.7834	173.88	33.53	33.61	20.00	40.00	20.125	11.0	43.063	20.812	10

600V, 5kV & 15kV SYSTEMS (INSULATED) COPPER CONDUCTORS

Amp Ratings	Figure	Weight (Lbs. per Foot)	Resistance (Micro-ohms per Foot)	Losses (Watts per Foot)	Reactance (Micro-ohms per Foot)	Impedance (Micro-ohms per Foot)	Typical Systems Dimensions - Inches						
							A	B	C	D	E	F	G
1200A	1	37.28	7.9513	34.35	53.49	54.08	16.00	27.00	16.125	7.5	30.063	16.812	8
1600A	1	37.28	8.5608	65.75	53.49	54.17	16.00	27.00	16.125	7.5	30.063	16.812	8
2000A	1	46.00	5.7576	69.09	45.69	46.05	16.00	27.00	16.125	7.5	30.063	16.812	8
3000A	1	67.07	3.6840	99.47	39.99	40.16	16.00	27.00	16.125	7.5	30.063	16.812	8
4000A	1	82.00	3.1436	150.89	34.53	34.68	20.00	40.00	20.125	12.0	43.063	20.812	10
5000A	2	110.99	1.9315	144.86	30.59	30.65	20.00	40.00	20.125	11.0	43.063	20.812	10

WALL OPENINGS

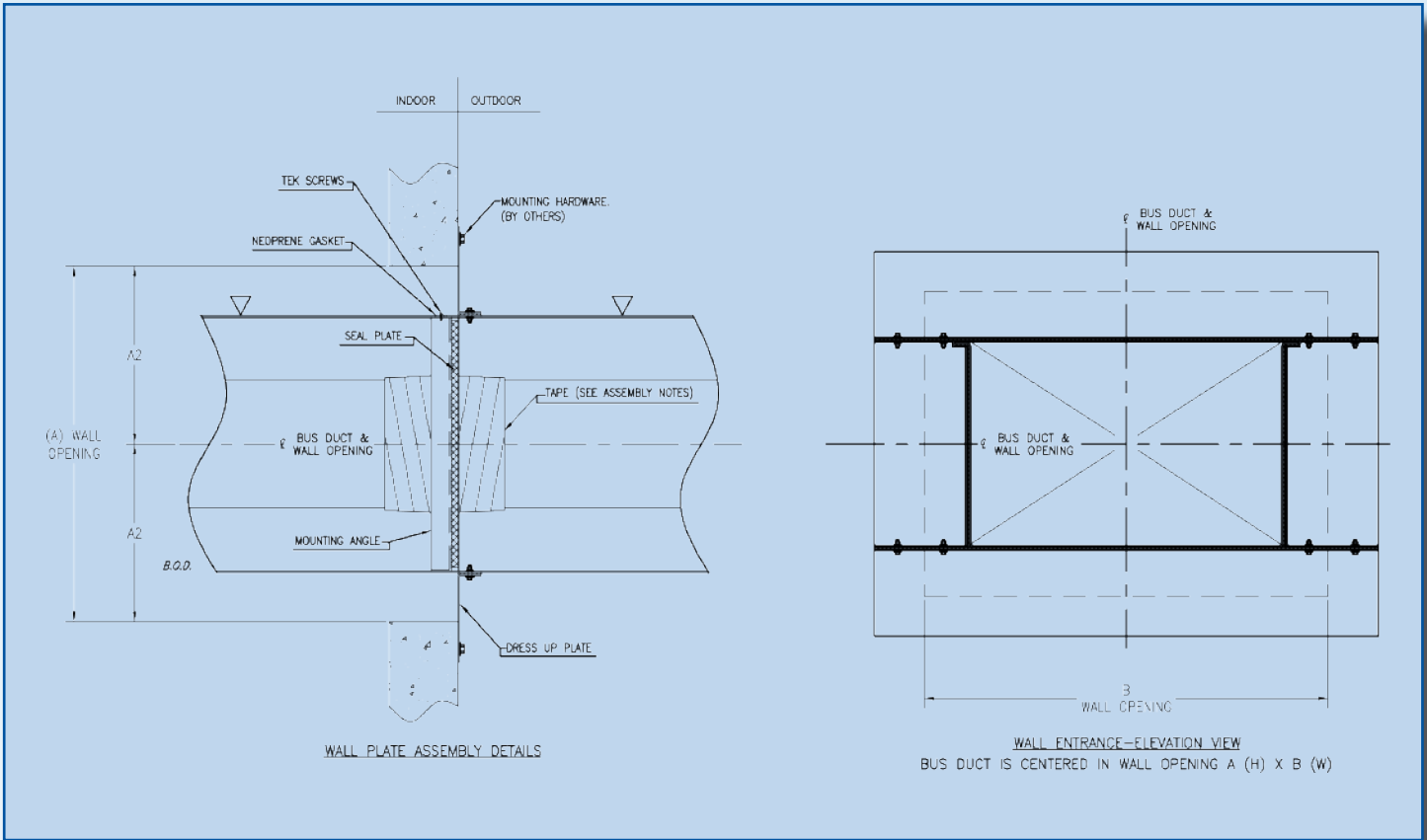

Typical Wall Opening Sizes:

Nominal Housing Size (H x W)	Dimensions (in Inches)	
	(A)	(B)
16.00" x 27.00"	20.00"	31.00"
20.00" x 40.00"	24.00"	44.00"

WALL PENETRATIONS

Calvert wall penetrations are available to complete the installation of the bus duct at the entrance to the building.

PROVEN SOLUTIONS

Calvert offers a range of vapor and fire barriers for wall penetration applications. Fire ratings of 1/2 hour, 1 hour, 2 & 3 hours, and 4 hours are available to meet customers' specifications.

STANDARD BUS COMPONENTS

Standard Bus Components 600V, 5kV & 15kV Designs

Amp Rating	A	B	C	D	E	F	G
1200	16"	27"	120"	Up to 96"	Up to 120"	Up to 120"	Up to 120"
1600	16"	27"	120"	Up to 96"	Up to 120"	Up to 120"	Up to 120"
2000	16"	27"	120"	Up to 96"	Up to 120"	Up to 120"	Up to 120"
3000	16"	27"	120"	Up to 96"	Up to 120"	Up to 120"	Up to 120"
4000	20"	40"	120"	Up to 96"	Up to 120"	Up to 120"	Up to 120"
5000	20"	40"	120"	Up to 96"	Up to 120"	Up to 120"	Up to 120"

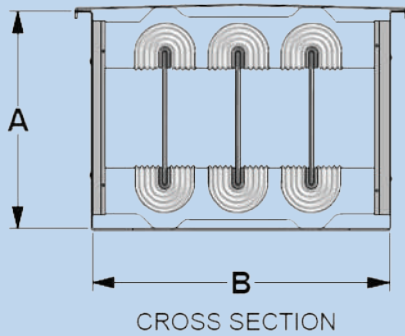

CROSS SECTION

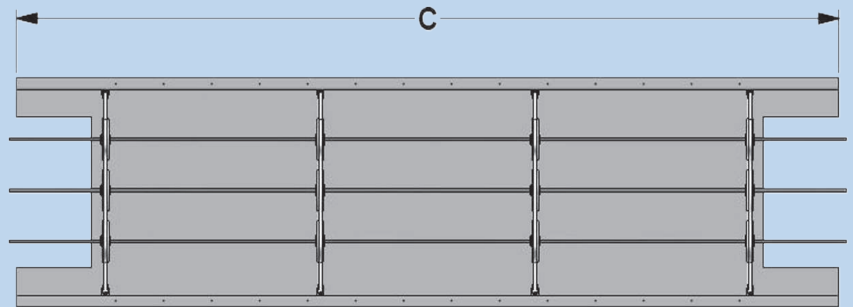

STRAIGHT SECTION

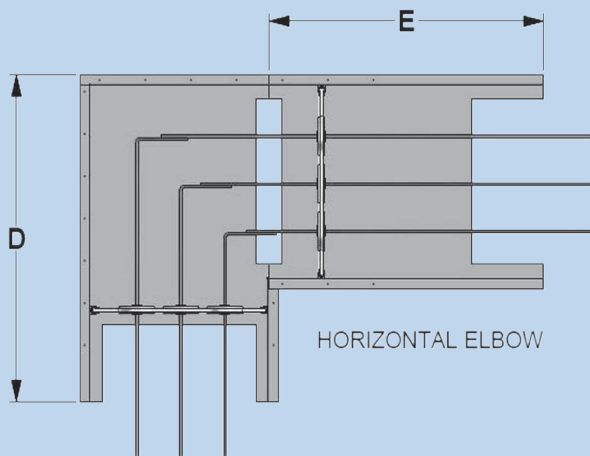

HORIZONTAL ELBOW

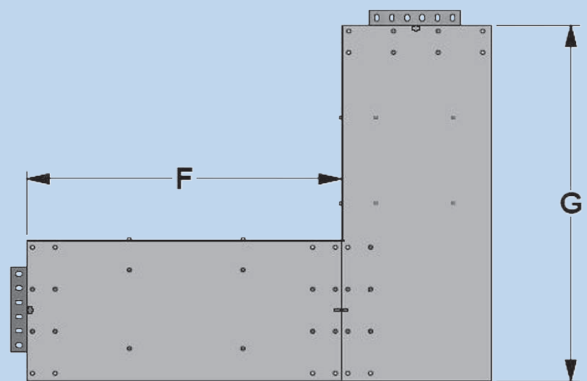

VERTICAL ELBOW

ADDITIONAL CALVERT PRODUCTS

ISOLATED PHASE BUS

Isolated Phase Bus is available for voltages from 15kV through 69kV, with ampere ratings up through 50,000 amps. Isolated Phase Bus has a single conductor for each phase in a separate metal enclosure. The enclosure and conductors are of aluminum material. The conductor is supported in the center of the housing on porcelain post insulators. The quantity and spacing of insulators is based on the momentary current ratings. The usual application for Isolated Phase Bus is the main generator leads in power plants (connecting the generator output to the main step-up transformer) and in circuits where the highest degree of reliability is required.

SEGREGATED PHASE BUS

Segregated Phase Bus systems are available for voltages ranging from 600 volts through 38kV, with ampere ratings up to 10,000 amps. Segregated phase systems utilize single-phase conductors in a common enclosure with metal barriers between the phases. Segregated phase bus systems are used as a generator lead in power generation plants, heavy industrial applications and metal-enclosed substations connecting to switchgear.

NON-SEGREGATED PHASE BUS

Non-Segregated Phase Bus is available for voltages ranging from 600 volts through 38kV, with ampere ratings up to 10,000 amps. Non-segregated phase bus has all phase conductors in a common enclosure with an air space between phases. Conductors may be mounted on Calvert's custom cycloaliphatic epoxy insulators, molded fiberglass polyester, or on porcelain post insulators. Enclosures that are totally enclosed are preferred, but ventilated enclosures can be provided for indoor applications. Typical applications include connections between transformers and switchgear, connections to motor control centers and generator leads.

DC BUS

DC bus can be supplied to meet the needs of direct current applications. Calvert manufactures DC bus with both poles contained in the same enclosure, or with each pole contained in a separate enclosure. DC Bus applications usually include generator excitation systems.

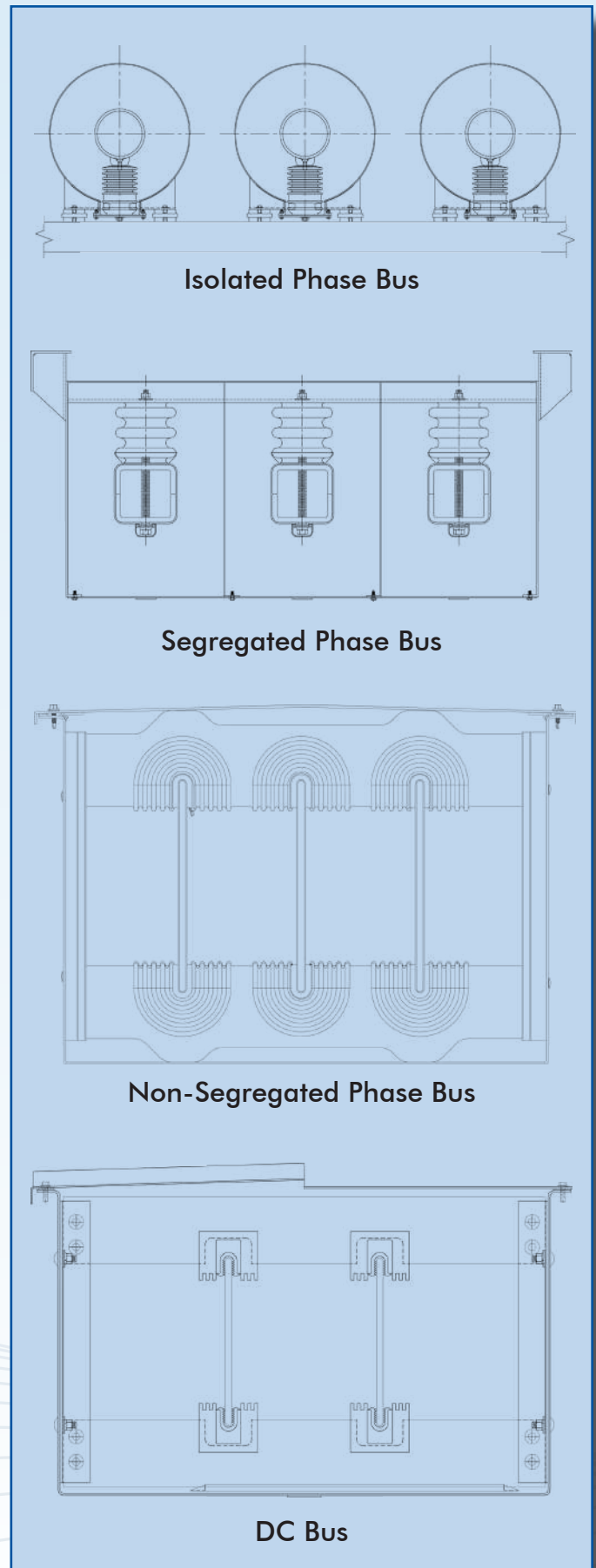

CALVERT INSTALLATION SERVICES

Doesn't it make sense for the leader in power bus systems to install and maintain your bus systems?

It should come as no surprise that the leader in power bus systems is also a leader in bus installations. Since 1957, Calvert Installation Services has supervised and/or turnkey installed all types of bus system applications.

From generation plants to industrial sites, including nuclear, Calvert can install and maintain your bus system to ensure that your bus system will operate at its peak performance levels.

When Calvert installs your bus system, we make sure that each step of the installation process is performed to all specifications. From owner preferences to the required standards, US or International, Calvert can provide the complete installation and service package. With Calvert you only deal with one contractor from initial design through manufacturing to installation.



Need emergency service or replacement parts?

A Calvert Field Representative can be at your location anywhere in the world as quickly as travel arrangements can be made. Your situation will be quickly assessed. Repairs can usually be made during the initial site visit. Modification or replacement parts can typically be shipped from the factory within 24 hours. Most stock parts can be shipped the same day.

Contact Calvert Installation Services for any service you require.

Calvert is your "Turnkey Supplier"



Whether you need stock parts or custom-designed parts, Calvert is the place to call. Flexible connectors, fabricated copper and aluminum parts, tapes, insulators, insulating boots, termination kits, hardware, sealants and more. Calvert can supply almost any replacement part you need fast. Contact Calvert Installation Services for your parts needs. Calvert is your "Parts Source".



NOTES



NOTES

