



DATA RACK BUSBAR

Data Rack Busbar Systems 160 A...800 A



DATA RACK BUSBAR



CONTENTS

►► DATA RACK BUSBAR

Overview	2-5
Technical Characteristics	6
Order Code System	7
Standard Length.....	8
Special Length.....	8
End Closer.....	8
Feeder Boxes	
Feeder Box B10.....	10
Feeder Box B11	11
Tap-Off Boxes	
KDP Terminal Box.....	12
KDP C13 & C19 Box	12
KDP Single Socket Box.....	13
KDP Double Socket Box.....	13
KDP Energy Analyzer Box.....	14
KDP Empty Box.....	14
Installation	
Joint Installation.....	16
Tap-Off Box Installation	17
Fixing Elements	
Application I : Threaded Rod with Snap-In Fixing Unit.....	18
Application II : TMP Ceiling Support with Snap-In Fixing Unit.....	18
Application III: TMP Ceiling Support and Tray Bracket with Snap-In Fixing Unit	19
Certificates	20
Declaration	21
Product Overview.....	22
Project Design Form	23-24

DATA RACK BUSBAR



►► Overview

To power the mission critical IT infrastructures on the Data Rack Cabinets, EAE offers a highly flexible and reliable Busbar System to meet the "Scalability" challenge in the Data Centers finding the way to Moves, Adds and Changes (MACs).

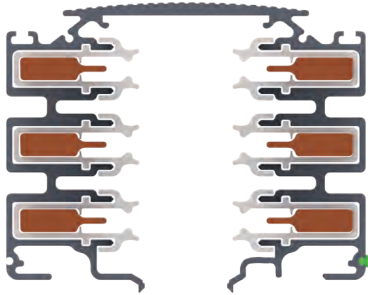

Al or Cu conductor options with whisker free coating



Whisker free and tin plated solid form conductors ensure for better heat dissipation, higher short circuit values and longer operation life while significantly contributing to the "Availability" challenge in the data center environments

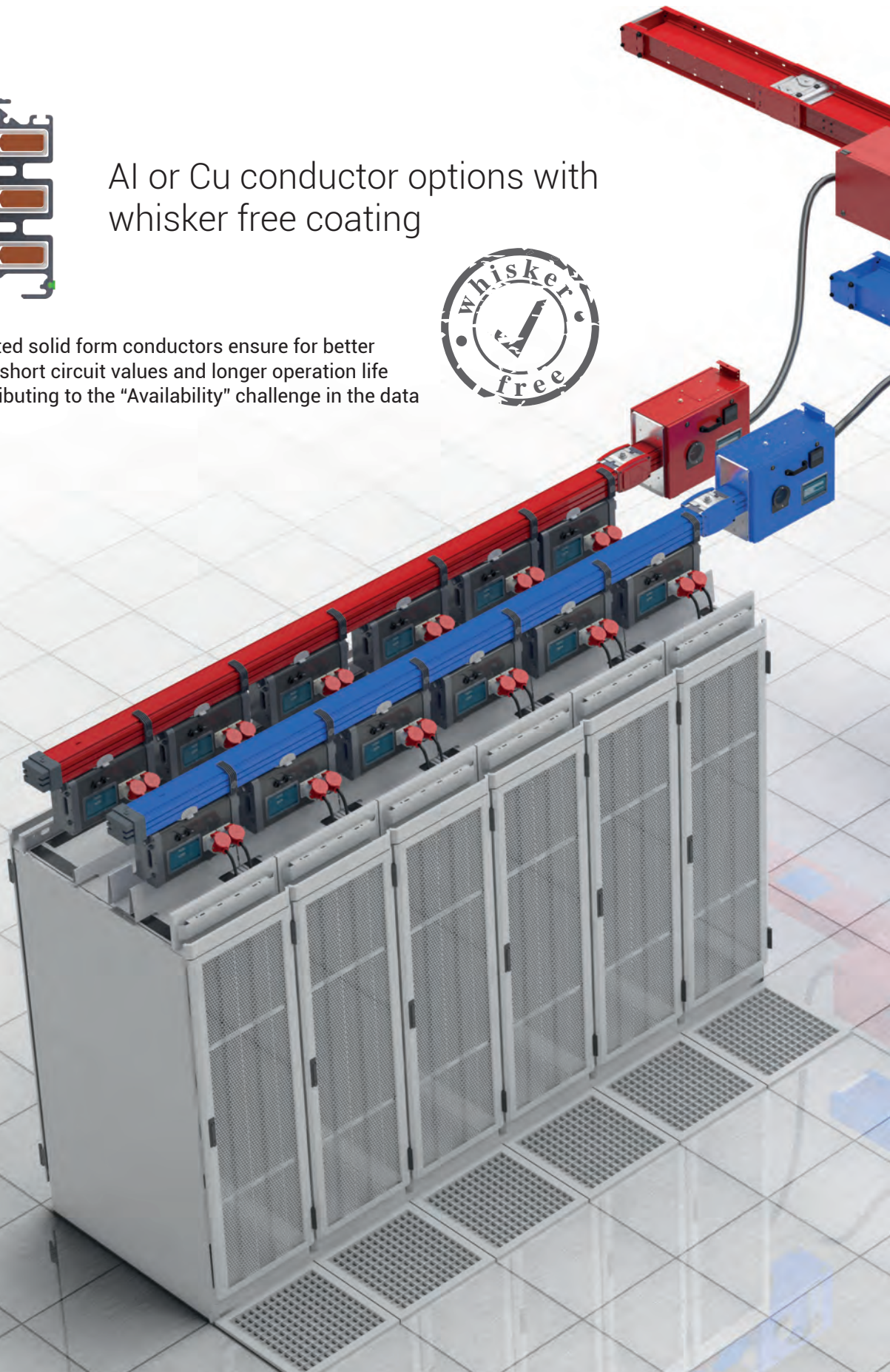

DATA RACK BUSBAR

►► Overview

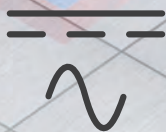
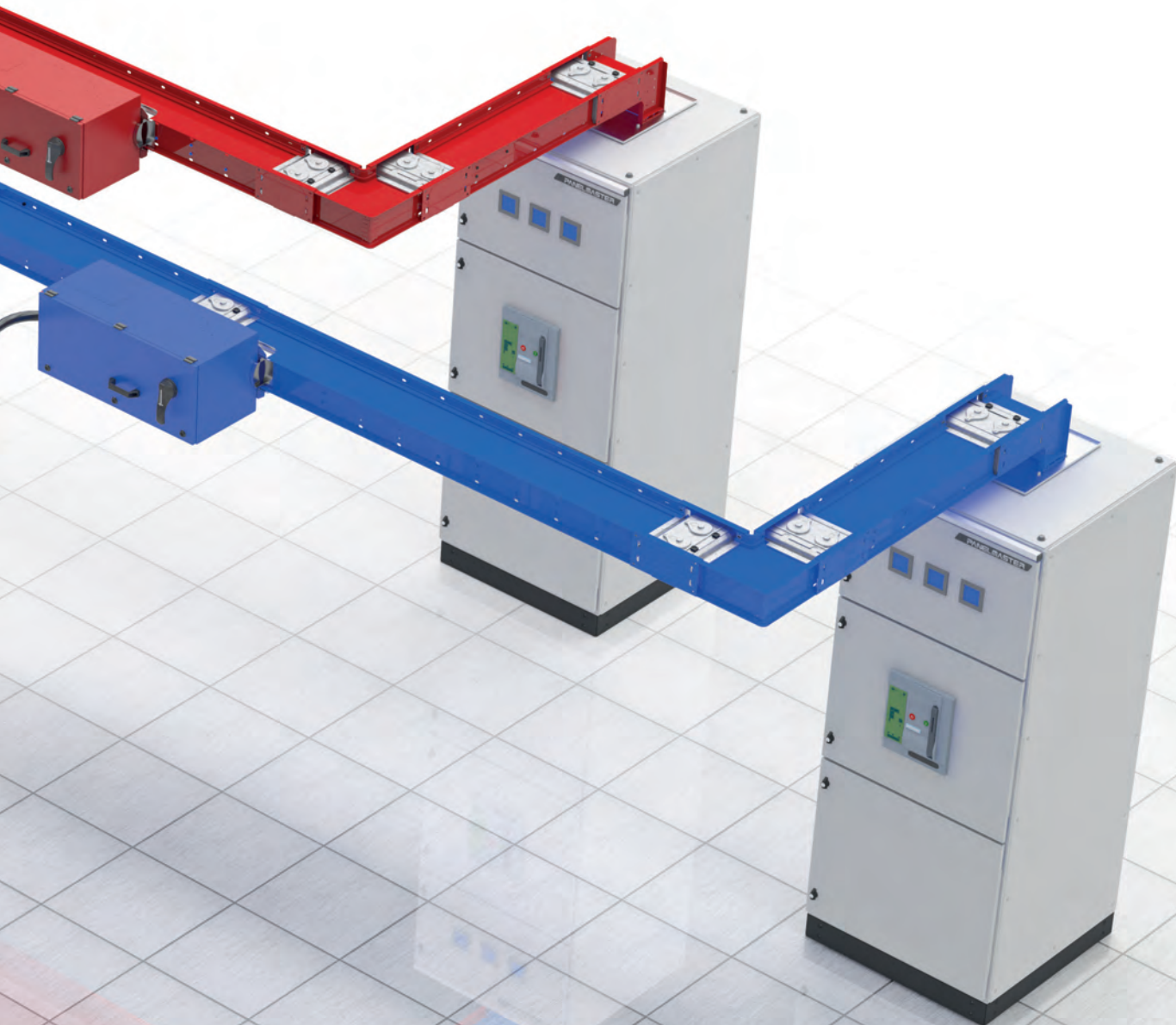

AC or DC feeding



Energy monitoring

IP23D

IP23D protection

DATA RACK BUSBAR

►►Overview

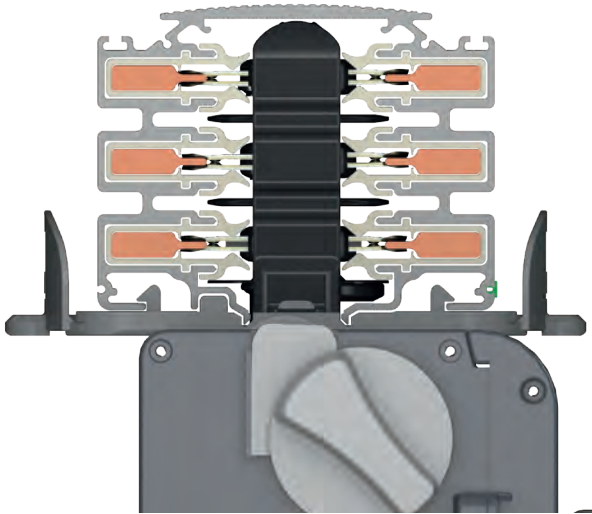

Plug-n-Play

Easy plug-in Tap-Off Boxes on any point along the busbar, remove and relocate wherever necessary

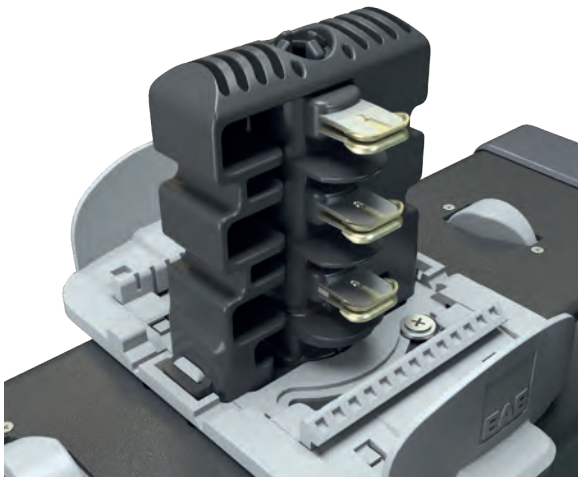

Tap-Off Contacts

Constant contact pressure with double sided spring system and safe locking mechanism on Tap-Off Box contacts



Snap-In Suspension Mechanism

Easy and fast structural mounting thanks to Snap-In Fixing Unit

DATA RACK BUSBAR

►► Overview

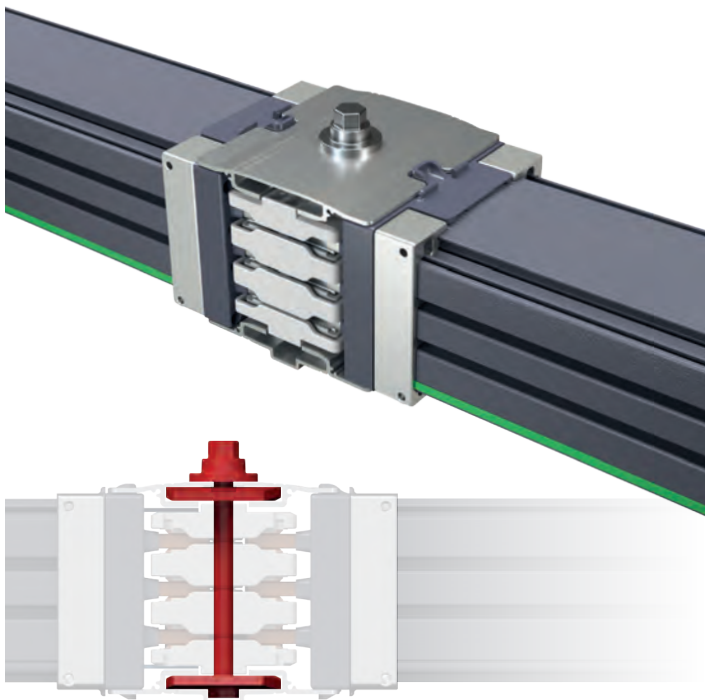

Joint Mechanism

Safe alignment mechanism with a single bolt monoblock joint for correct installation and operation

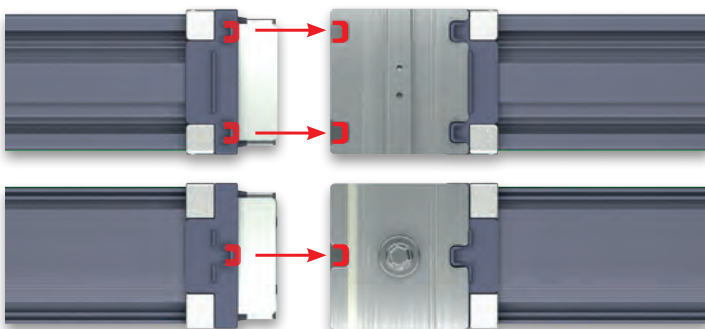

Easy and Safe Installation

Patented EAE Alignment Solution, ideal alignment of the block joint element and busbar thanks to the alignment guides on the joint area



DATA RACK BUSBAR

►► Technical Characteristics



Standards	IEC 61439-6, TS EN 61439-6, IEC 61439-1, TS EN 61439-1
Rated Isolation Voltage	Ui: 1000 V at Cat IV
Max. Rated Operational Voltage	Ue: 1000 Vac
Rated Impulse Withstand Voltage	Uimp: 12 kV
Rated Frequency	f: 50 Hz
Pollution Degree	III
Protection Degree	IP23D
External Mechanical Impacts (IK Code)	IK08
Protection for Safety	Basic Protection (HD 60364-4-41, Clause A1)

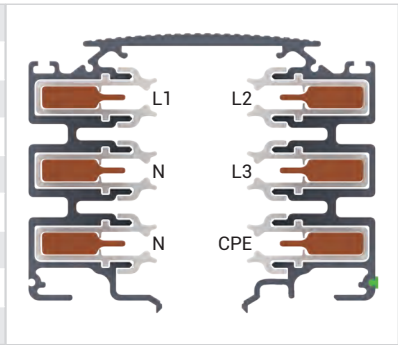

			Al				Cu			
RATED CURRENT	I_n	A	160	250	400	630	250	400	630	800
BUSBAR CODE			01	02	04	06	02	04	06	08
MEAN PHASE CONDUCTOR CHARACTERISTICS AT RATED CURRENT										
Resistance at a conductor temperature of 20 °C	R_{20}	mΩ/m	0,358	0,352	0,234	0,159	0,215	0,211	0,140	0,101
Average resistance at I_n , thermal balance	R	mΩ/m	0,403	0,402	0,283	0,211	0,246	0,258	0,188	0,133
Reactance (Independent from Temperature)	X	mΩ/m	0,098	0,100	0,087	0,077	0,100	0,101	0,090	0,077
Positive and negative sequence impedances at an ambient air temperature of 35 °C	Z	mΩ/m	0,415	0,437	0,311	0,233	0,265	0,292	0,217	0,159
Positive and negative sequence impedances at a conductor temperature of 20 °C	Z_{20}	mΩ/m	0,371	0,366	0,249	0,177	0,237	0,233	0,167	0,127
Rated Power Loss at I_n		W/m	31	75,4	135,8	251,2	46	123,8	223,9	255,4
Aluminium Housing Section (Aluminium)		mm ²	94	3302	3302	3302	94	3302	3302	3302
Busbar Weight (4 Conductors)		kg/m	11,1	11,1	12,3	12,6	13,6	13,6	11,6	14,3
Busbar Weight (5 Conductors)		kg/m	11,4	11,4	11,8	13,3	14,6	14,6	13,0	17,0
Busbar Weight (6 Conductors)		kg/m	11,6	11,6	12,3	14,0	15,3	15,3	14,3	18,3
MEAN FAULT-LOOP CHARACTERISTICS										
ZERO-SEQUENCE IMPEDANCE										
Zero-sequence impedance at a conductor temperature of 20 °C	$Z_{(0)b20phN}$	mΩ/m	1,500	1,482	1,016	0,725	0,657	0,949	0,682	0,501
Zero-sequence impedance at a conductor temperature of 20 °C (Housing)	$Z_{(0)b20phPE}$	mΩ/m	0,436	0,701	0,350	0,287	0,296	0,367	0,292	0,193
Zero-sequence impedance at a conductor temperature of 20 °C (Double Notr)	$Z_{(0)b20ph2N}$	mΩ/m	0,996	0,988	0,686	0,510	0,952	0,649	0,485	0,358
Zero-sequence impedance at a conductor temperature of 20 °C (CPE)	$Z_{(0)20phCPE}$	mΩ/m	1,512	1,509	1,039	0,743	0,973	0,962	0,707	0,518
Zero-sequence impedance at an ambient temperature of 35 °C	$Z_{(0)bphN}$	mΩ/m	1,682	1,775	1,272	0,968	0,736	1,191	0,902	0,636
Zero-sequence impedance at an ambient temperature of 35 °C (Housing)	$Z_{(0)bphPE}$	mΩ/m	0,485	0,844	0,441	0,389	0,334	0,470	0,400	0,256
Zero-sequence impedance at an ambient temperature of 35 °C (Double Notr)	$Z_{(0)bph2N}$	mΩ/m	1,114	1,184	0,856	0,680	1,067	0,814	0,643	0,456
Zero-sequence impedance at an ambient temperature of 35 °C (CPE)	$Z_{(0)bphCPE}$	mΩ/m	1,691	1,807	1,300	0,989	1,089	1,206	0,934	0,659
RESISTANCES AND REACTANCES										
Resistance at a conductor temperature of 20 °C	$R_{b20phph}$	mΩ/m	0,717	0,722	0,483	0,346	0,436	0,433	0,305	0,222
Resistance at a conductor temperature of 20 °C	R_{b20phN}	mΩ/m	0,726	0,718	0,479	0,342	0,434	0,434	0,301	0,219
Resistance at a conductor temperature of 20 °C (Double Notr)	$R_{b20ph2N}$	mΩ/m	0,553	0,558	0,373	0,274	0,344	0,340	0,241	0,178
Resistance at a conductor temperature of 20 °C (Housing)	$R_{b20phPE}$	mΩ/m	0,376	0,473	0,271	0,207	0,237	0,261	0,192	0,136
Resistance at a conductor temperature of 20 °C (CPE)	$R_{b20phCPE}$	mΩ/m	0,717	0,723	0,485	0,343	0,437	0,427	0,305	0,223
Resistance at an ambient air temperature of 35 °C	R_{bphph}	mΩ/m	0,809	0,875	0,618	0,479	0,498	0,562	0,430	0,305
Resistance at an ambient air temperature of 35 °C	R_{bphN}	mΩ/m	0,804	0,869	0,613	0,473	0,496	0,564	0,424	0,301
Resistance at an ambient air temperature of 35 °C (Double Notr)	R_{bph2N}	mΩ/m	0,623	0,676	0,478	0,378	0,393	0,442	0,339	0,245
Resistance at an ambient air temperature of 35 °C (Housing)	R_{bphPE}	mΩ/m	0,424	0,572	0,347	0,286	0,270	0,339	0,271	0,187
Resistance at an ambient air temperature of 35 °C (CPE)	R_{bphCPE}	mΩ/m	0,809	0,875	0,620	0,475	0,499	0,555	0,430	0,307
Reactance (Independent from temperature)	X_{bphph}	mΩ/m	0,198	0,194	0,169	0,141	0,194	0,196	0,170	0,142
Reactance (Independent from temperature)	X_{bphN}	mΩ/m	0,200	0,199	0,170	0,140	0,196	0,197	0,169	0,141
Reactance (Double Notr) (Independent from temperature)	X_{bph2N}	mΩ/m	0,149	0,152	0,135	0,114	0,140	0,157	0,137	0,113
Reactance (Housing) (Independent from temperature)	X_{bphPE}	mΩ/m	0,098	0,103	0,086	0,075	0,097	0,102	0,088	0,072
Reactance (CPE) (Independent from temperature)	X_{bphCPE}	mΩ/m	0,201	0,199	0,173	0,145	0,199	0,214	0,174	0,146

DATA RACK BUSBAR

►►Order Code System

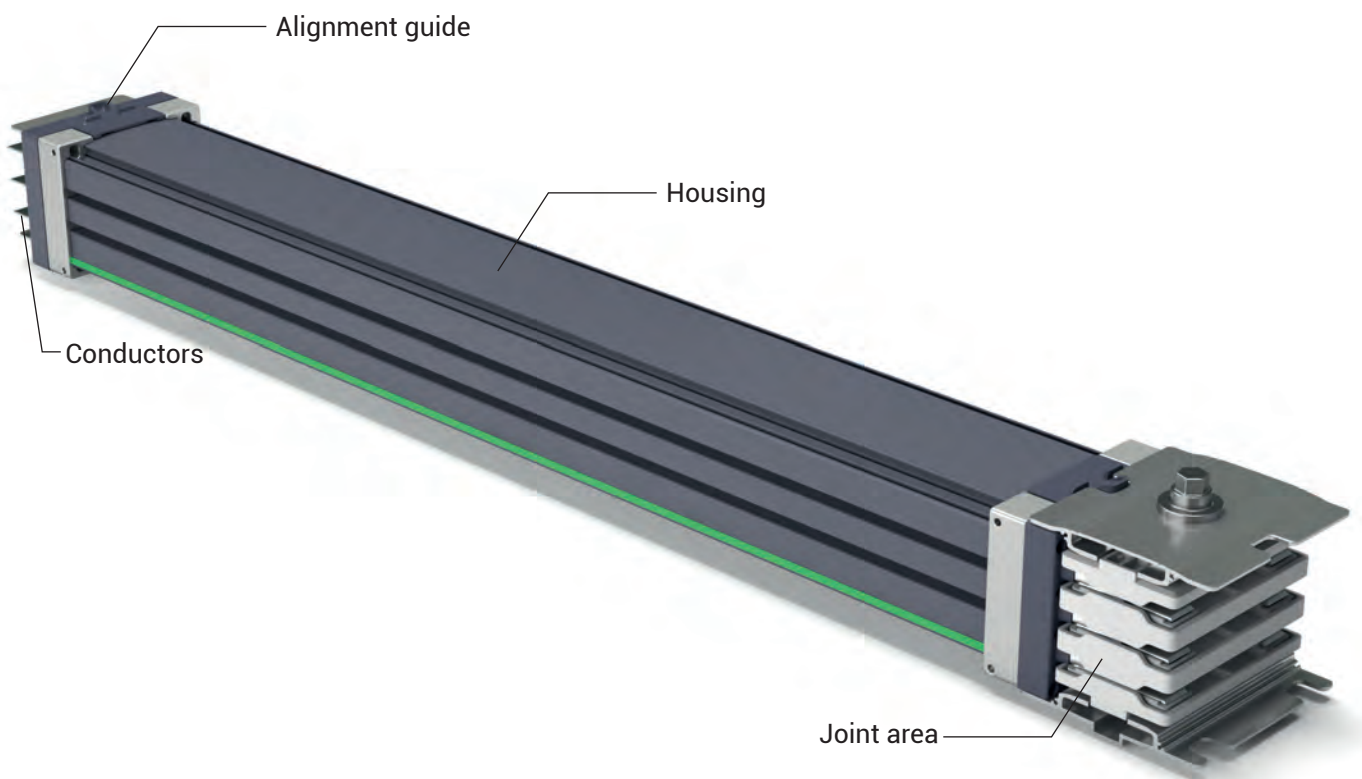
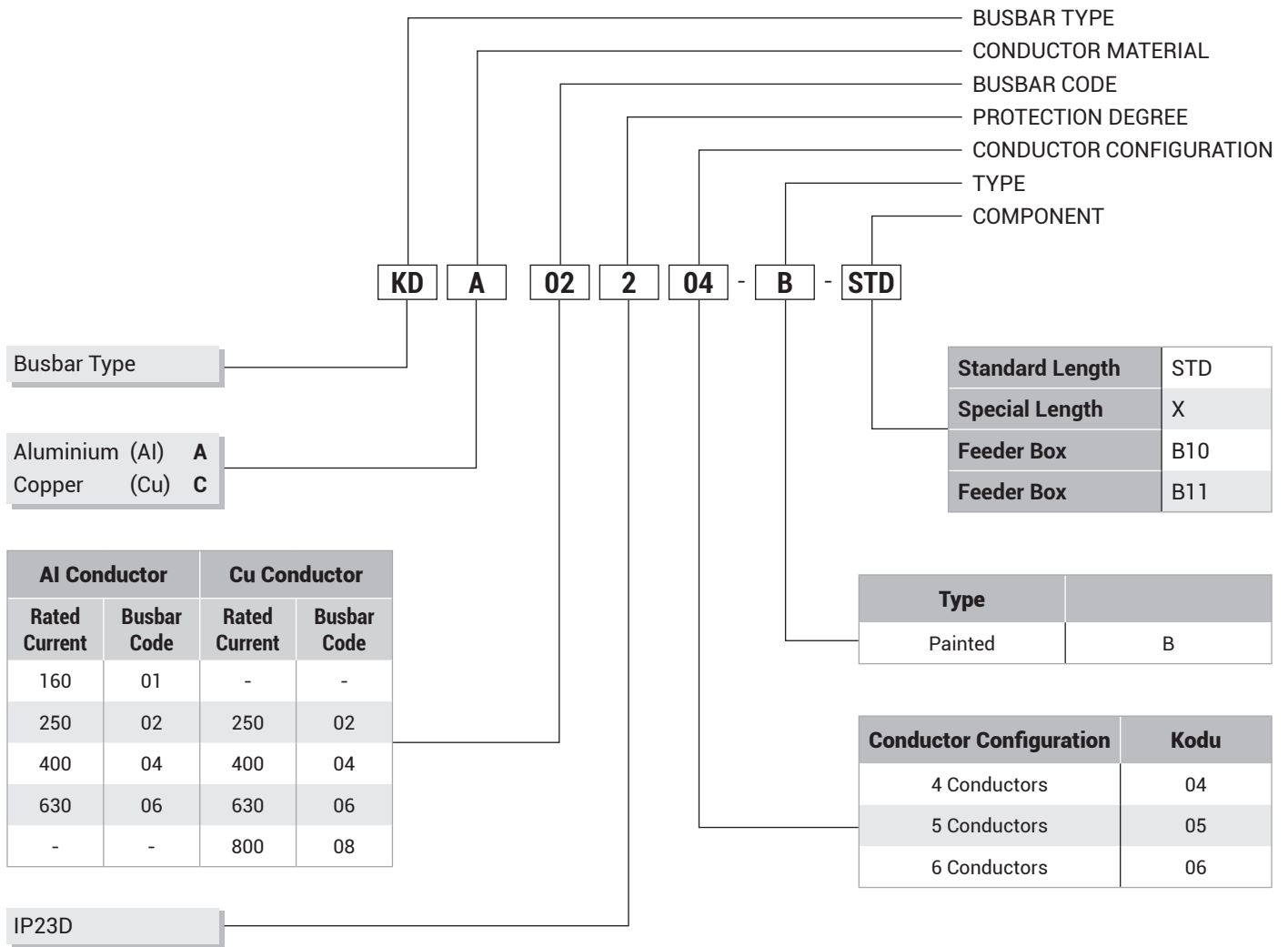

DATA RACK BUSBAR



►►Standard Length

Sample Order:

250 A, Aluminium,
IP23D, 6 Conductors,
Painted
KDA 02206-B-STD

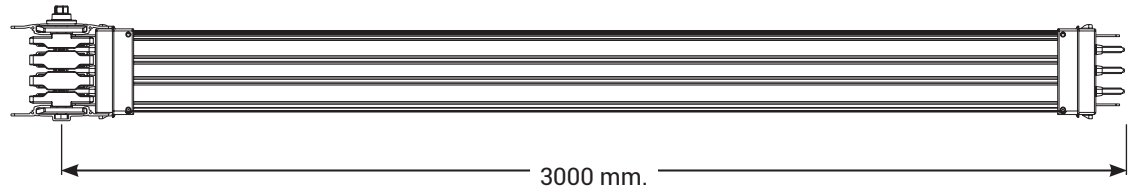

►►Special Length

Sample Order:

250 A, Aluminium, IP23D, 6 Conductors, 150 cm.
KDA 02206-X-150

Note:

Minimum Length (X)=35 cm.

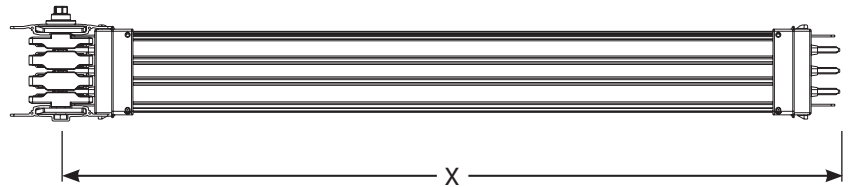

►End Closer

It is used to close the end of the busbar run and included on all standart and special lenght of busbars.

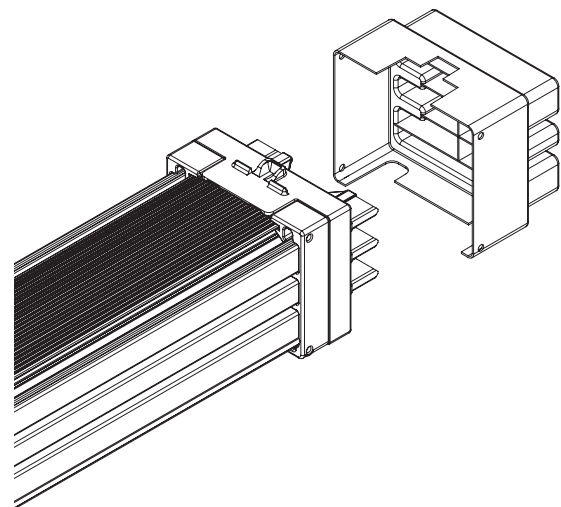

DATA RACK BUSBAR

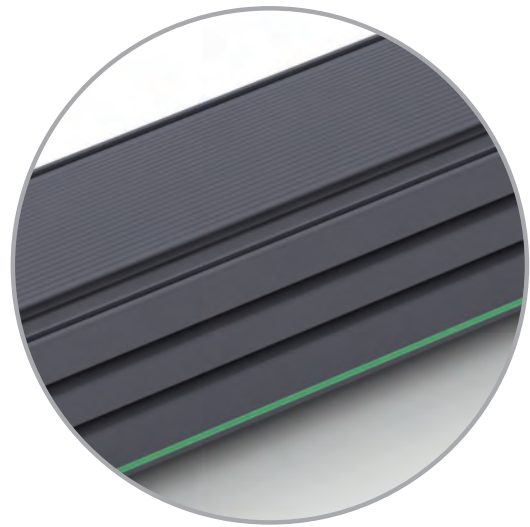
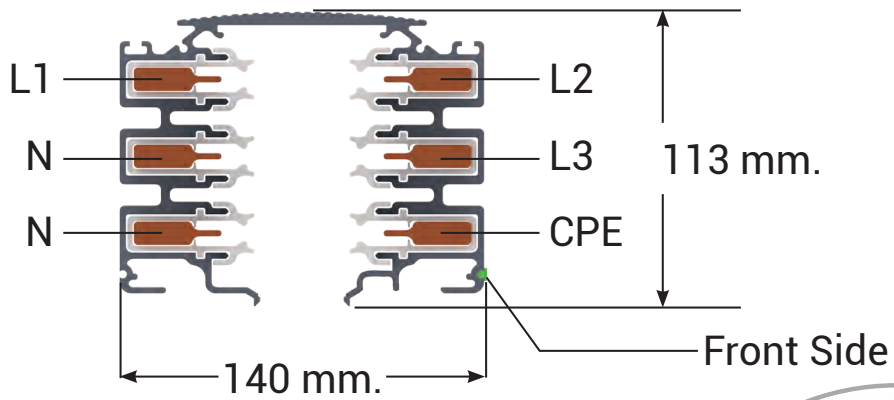

Al Conductor		Cu Conductor	
Rated Current	Busbar Code	Rated Current	Busbar Code
160	01	-	-
250	02	250	02
400	04	400	04
630	06	630	06
-	-	800	08

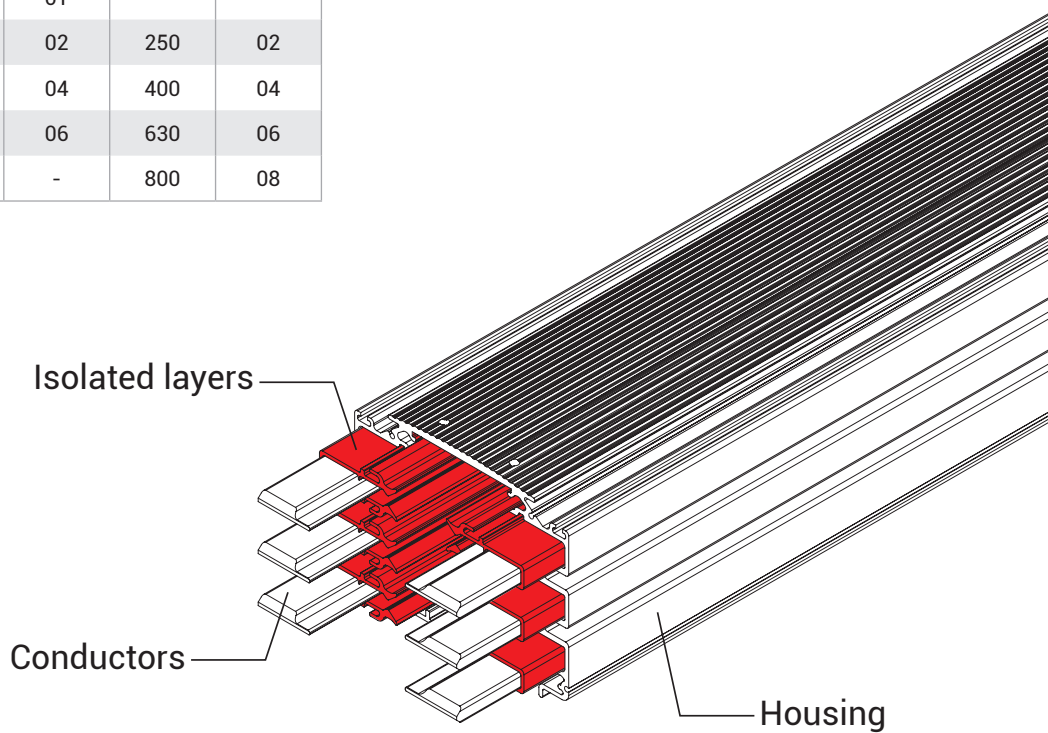

DATA RACK BUSBAR

►► Feeder Boxes 630A (Al), 800A (Cu)

► Feeder Box B10 (Orientation : Right → Left)

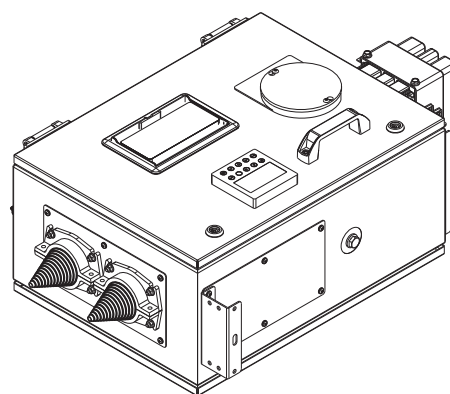
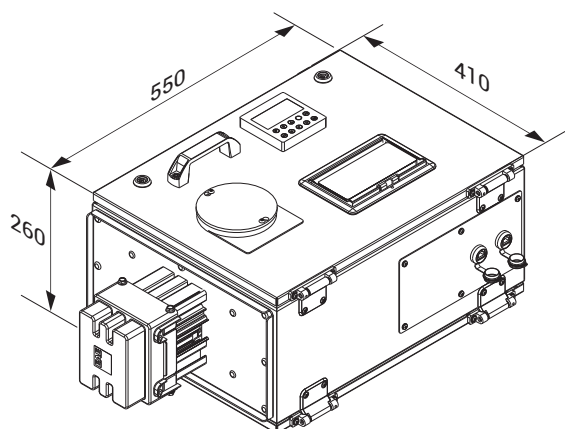
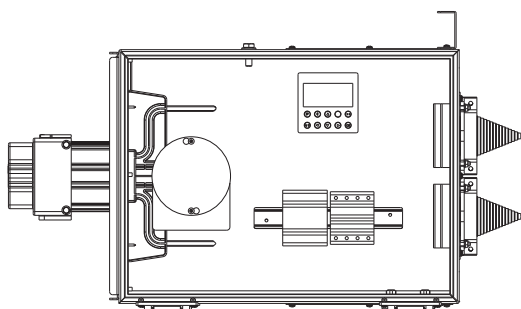

- Hinged and easily removable cover
- IR window (optional)
- Energy Monitoring (optional)

DATA RACK BUSBAR

►► Feeder Boxes 630A (Al), 800A (Cu)

► Feeder Box B11 (Orientation : Left → Right)

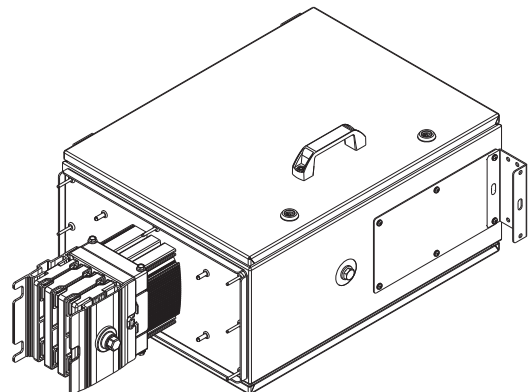
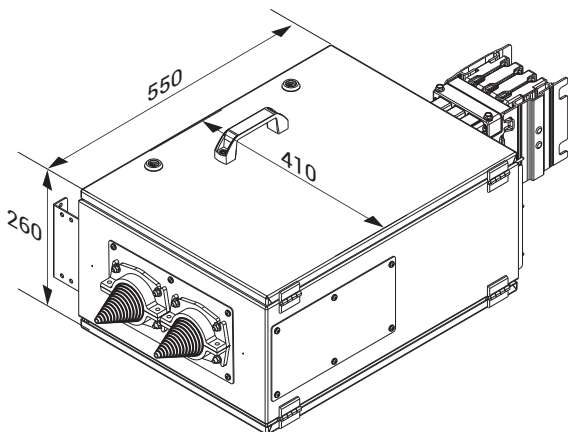
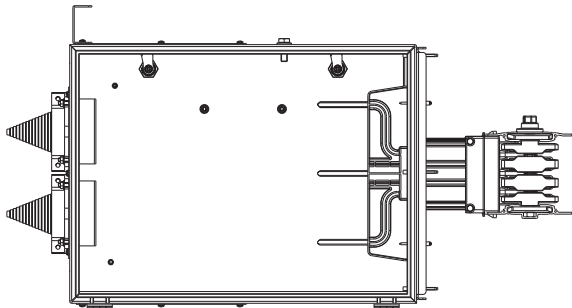

- Hinged and easily removable cover
- IR window (optional)
- Energy Monitoring (optional)

DATA RACK BUSBAR

▶▶ Tap-Off Boxes

▶KDP Terminal Box (80A)



16A/32A Single & Three Phase Circuit Breaker
16A/32A, 3P & 5P Connector with cable
RJ45 Ports (Optional for Energy Metering)

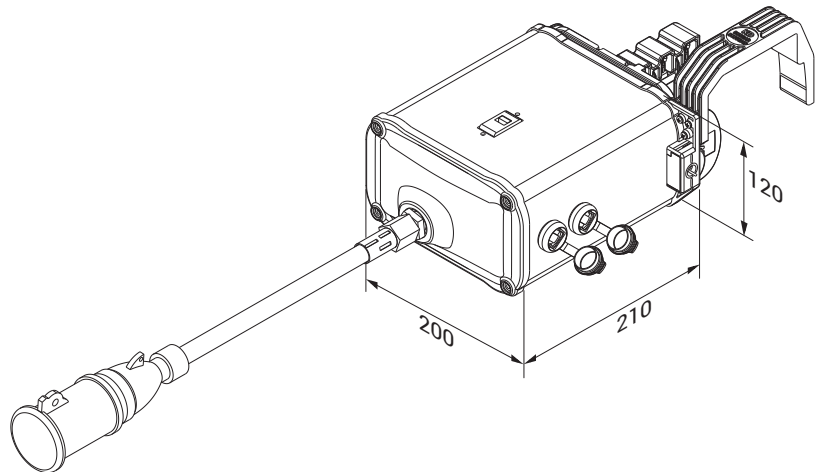

▶KDP C13 & C19 Box (125A)



16A Single Phase Circuit Breaker
C13 & C19 Sockets
RJ45 Ports (Optional for Energy Metering)

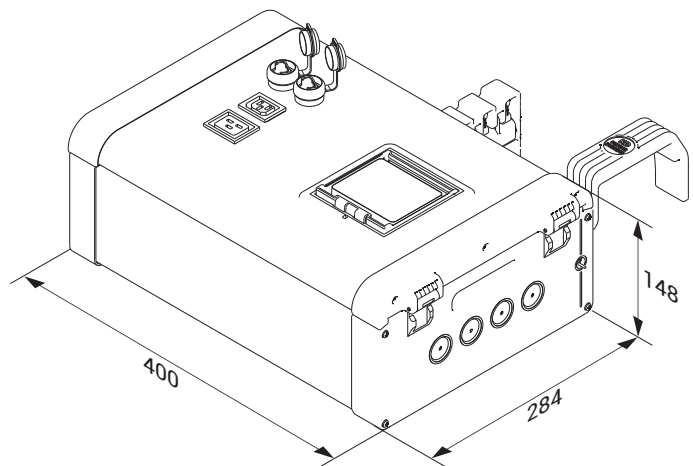

DATA RACK BUSBAR

▶▶ Tap-Off Boxes

▶ KDP Single Socket Box (125A)



- 16A/32A Single & Three Phase Circuit Breaker
- 63A Three Phase Circuit Breaker
- 16A/32A Single & Three Phase Socket
- 63A Three Phase Socket
- RJ45 Ports (Optional for Energy Metering)

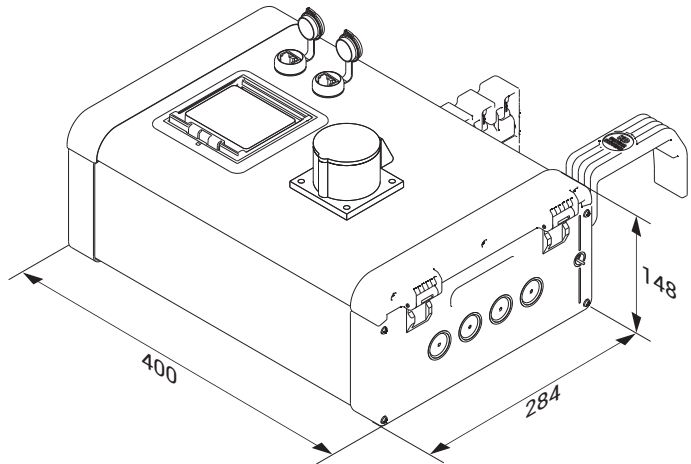

▶ KDP Double Socket Box (125A)

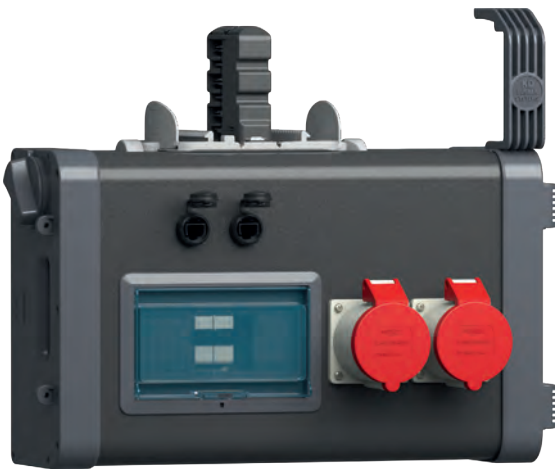

- 16A/32A Single & Three Phase Circuit Breakers
- 16A/32A Single & Three Phase Sockets
- RJ45 Ports (Optional for Energy Metering)

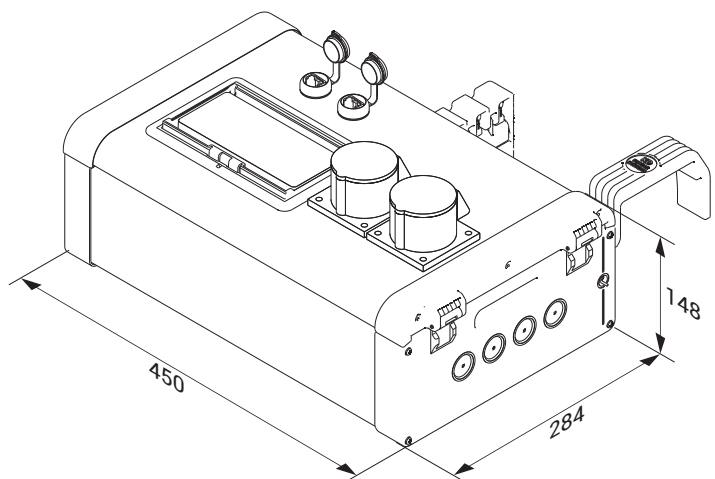

DATA RACK BUSBAR



▶▶ Tap-Off Boxes

▶ KDP Energy Analyzer Box (125A)



16A/32A Single & Three Phase Circuit Breakers
63A Three Phase Circuit Breaker
16A/32A Single & Three Phase Socket
63A Three Phase Socket
Energy Analyzer with Display
RJ45 Ports

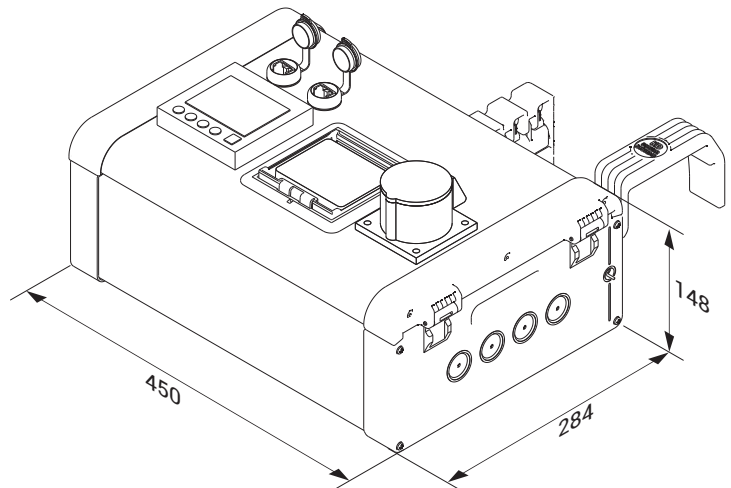

▶ KDP Empty Box (125A)

Configurable up to 12 modules with RJ45 ports with optional cable gland feed.

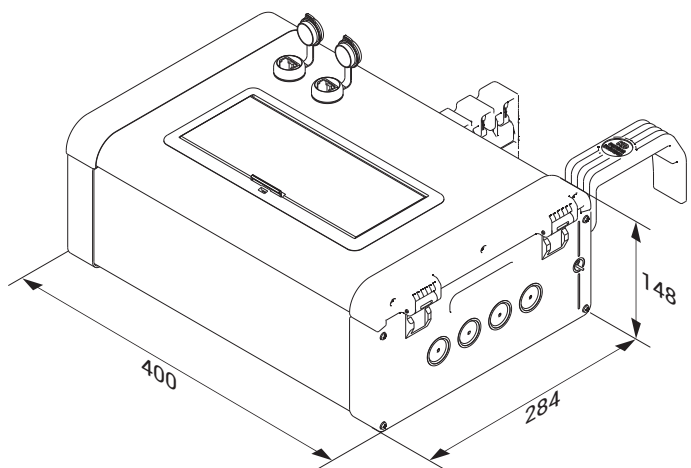
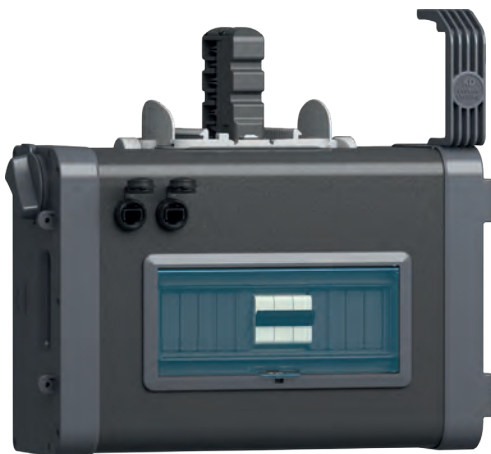



DATA RACK BUSBAR

►► Installation

► Joint Installation

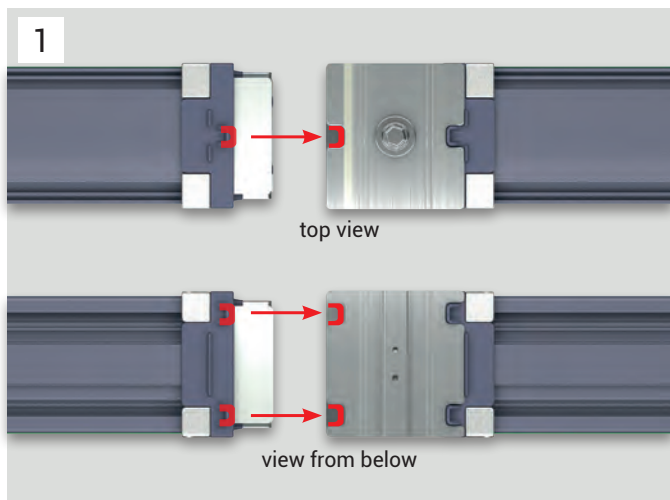

Align the busbars those with and without block joints facing each other and insert together

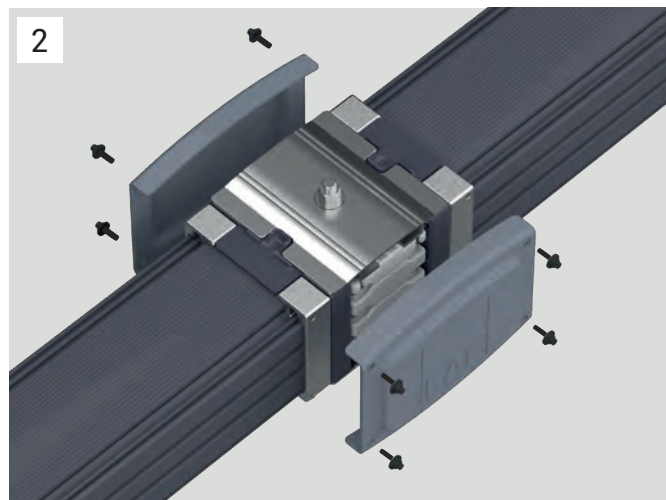

Assemble the joint cover and tighten the cover bolts

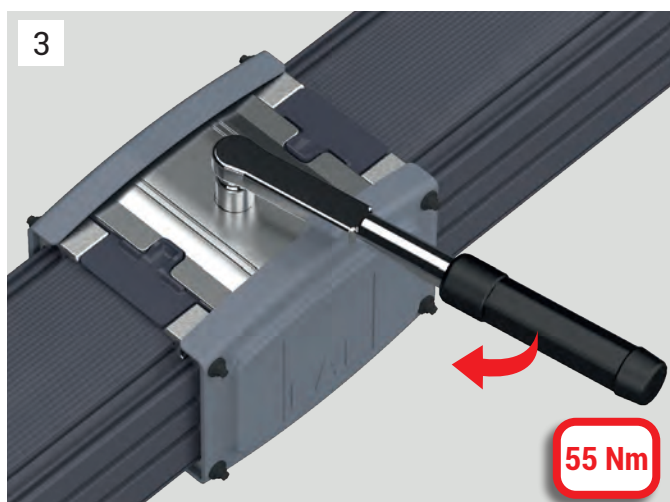

Adjust the torque wrench to 55 Nm and tighten the joint nut

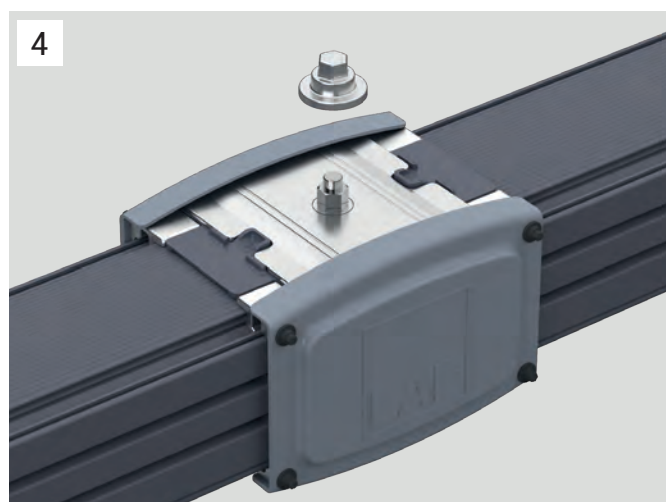

Mount the nut locking piece on the nut

DATA RACK BUSBAR

►► Installation

► Tap-Off Box Installation

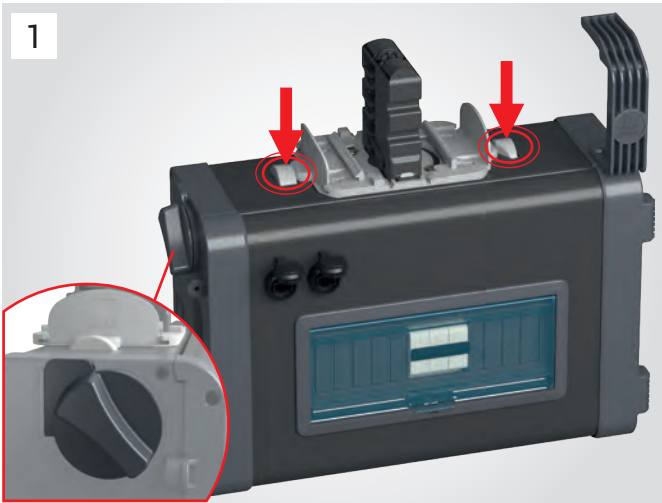

Ensure that the locking latch position is set right (as indicated) and setup the installation mechanism by pressing on the claws

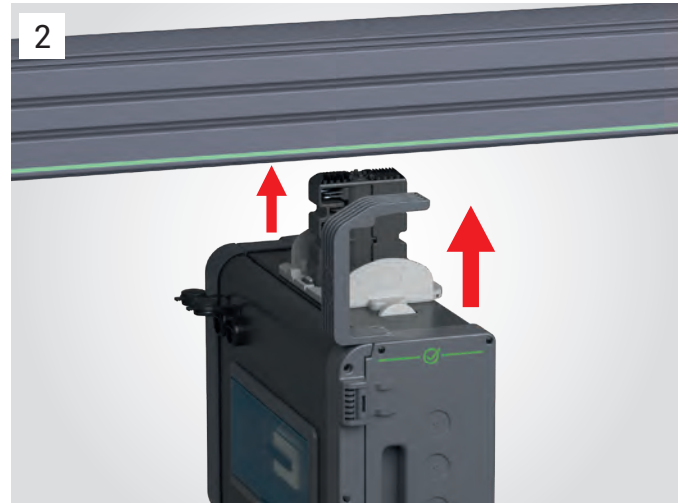

Insert the box inside the slot of the busbar by facing the mounting angle, the box label and the housing 'green' reference line on the same side

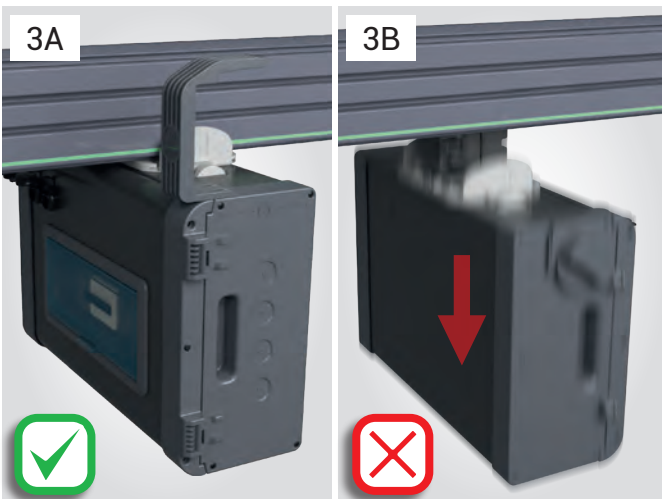

Assure that the box is inserted and locked inside the busbar slot

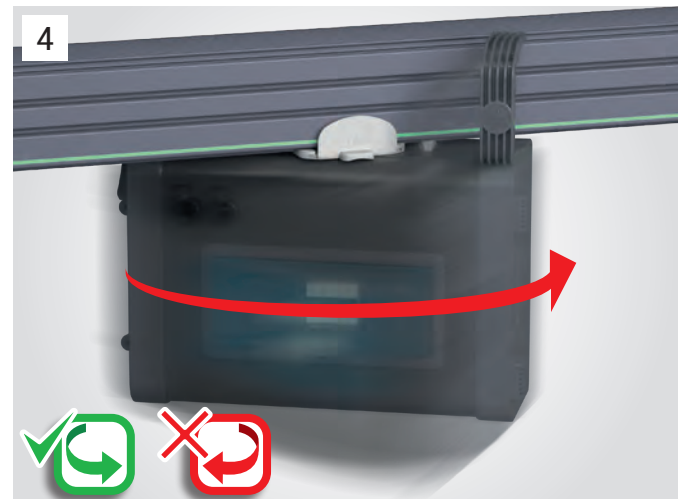

Engage the top off box by rotating in the direction of the arrow

Do not rotate the box against the direction of the arrow

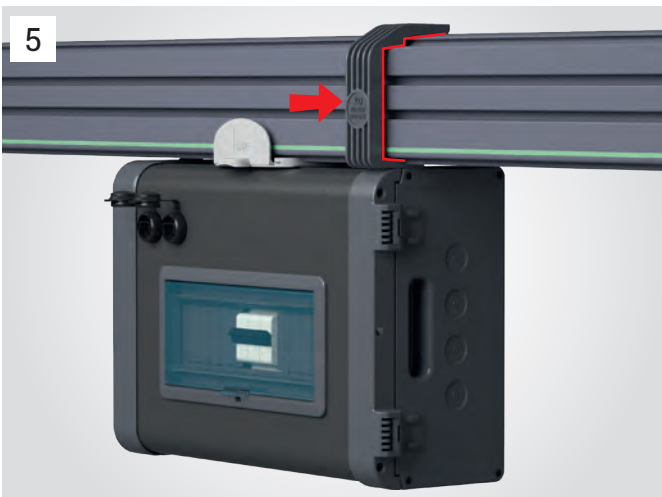

Ensure that the mounting angle is correctly attached on the busbar housing



Secure the box by turning the locking latch in direction of the arrow

DATA RACK BUSBAR



►► Fixing Elements

► Application I : Threaded Rod with Snap-In Fixing Unit

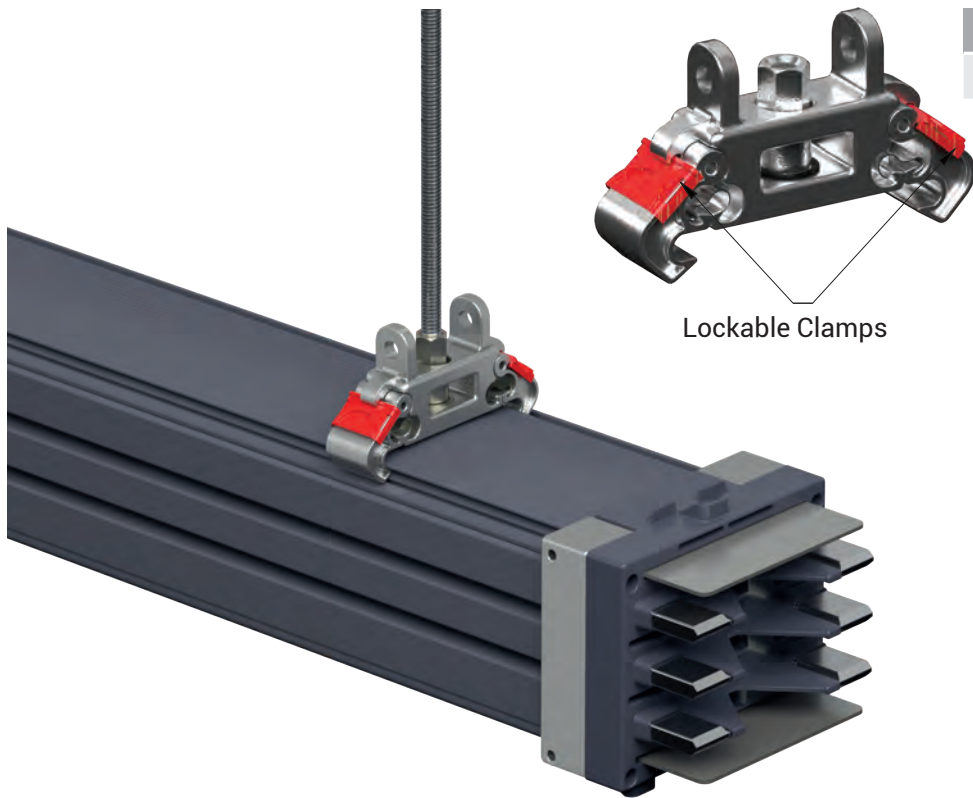

THREADED ROD SUPPORT	
KD SNAP-IN	1024388

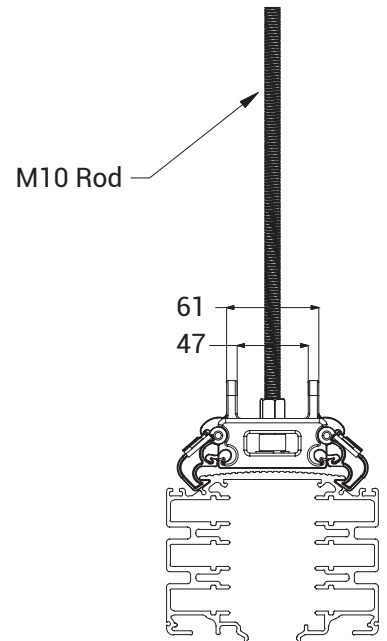

► Application II : TMP Ceiling Support with Snap-In Fixing Unit

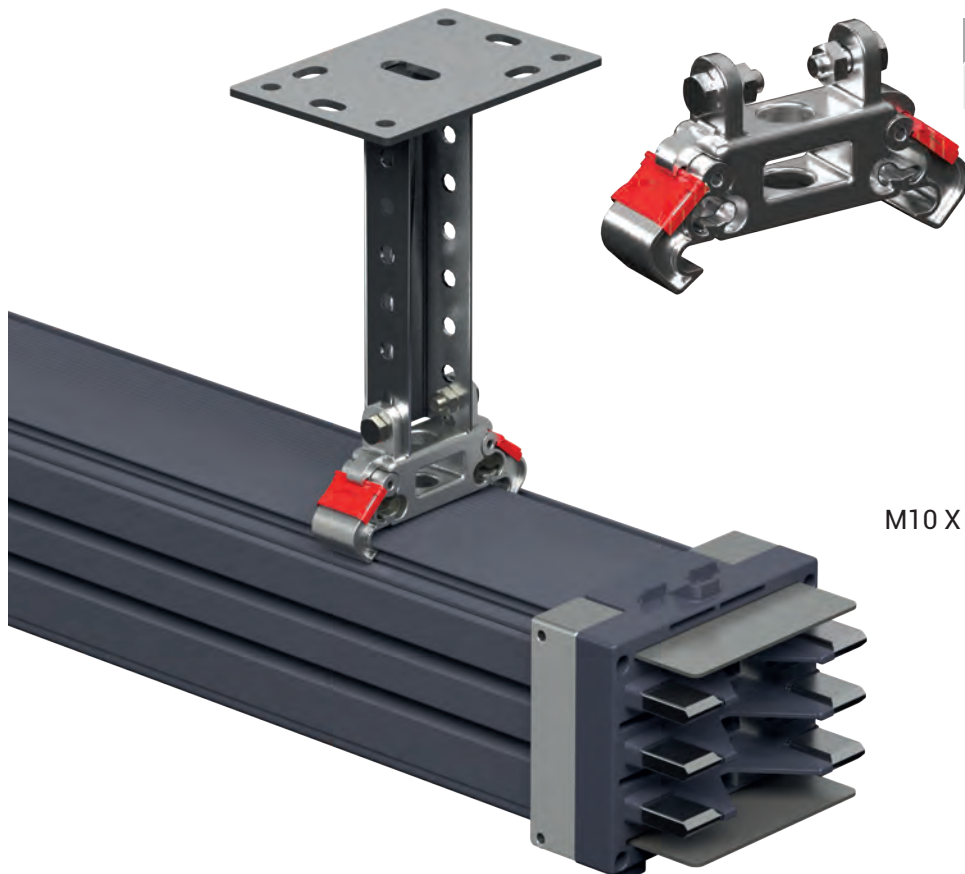

TMP CEILING SUPPORT	
KD SNAP-IN	1024389

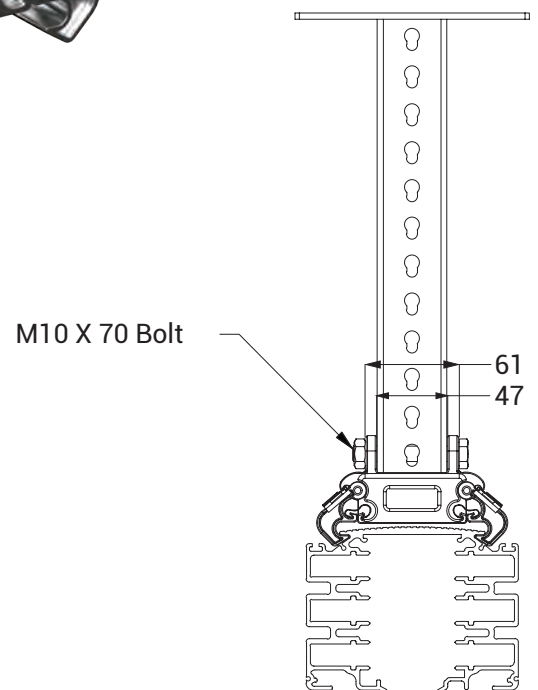

DATA RACK BUSBAR

►► Fixing Elements

► Application III : TMP Ceiling Support and Tray Bracket with Snap-In Fixing Unit

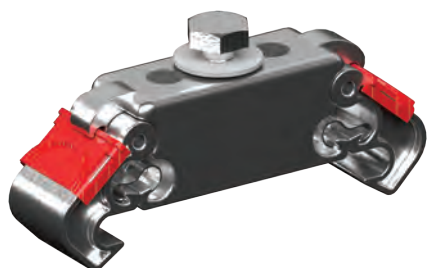
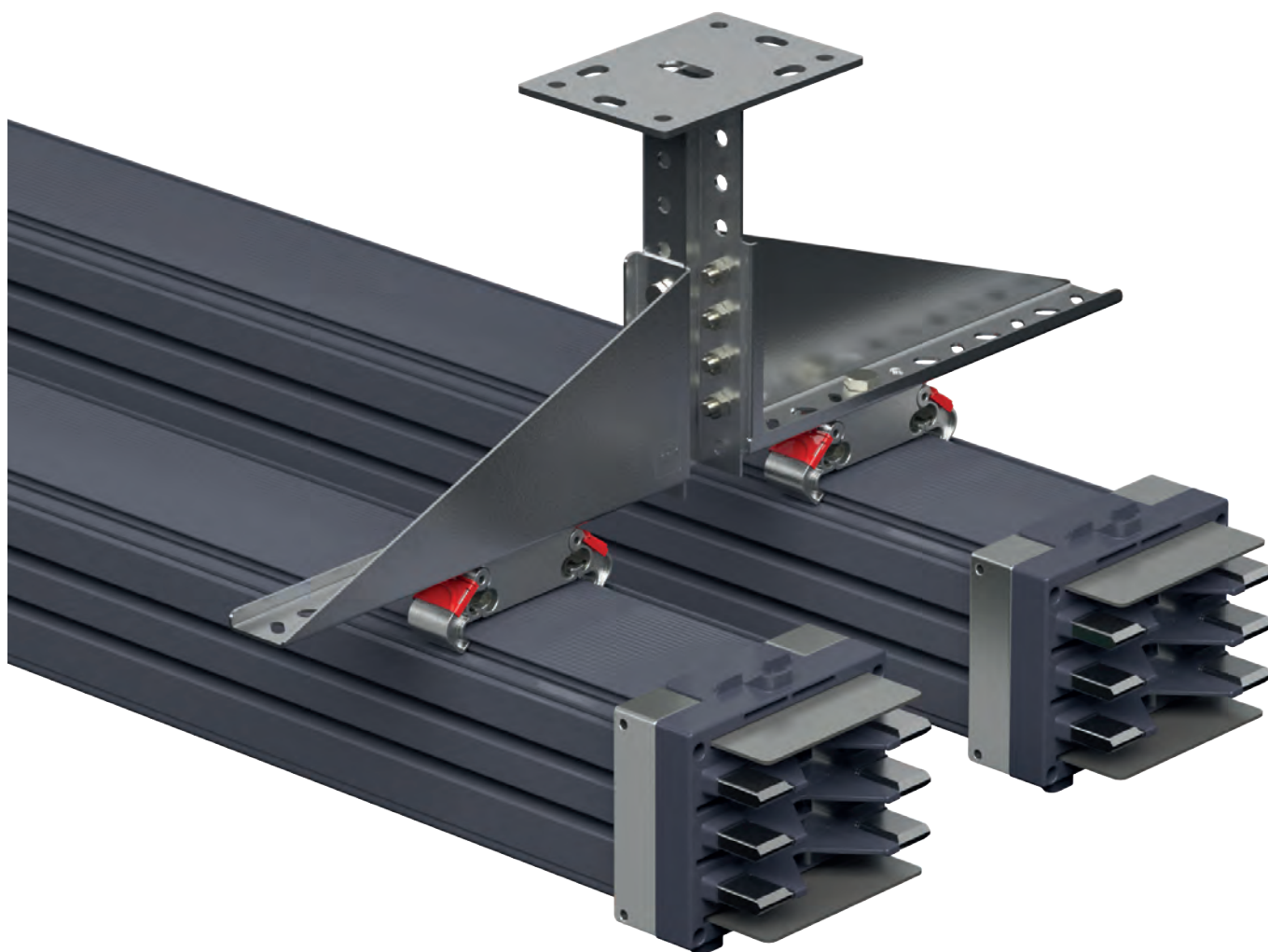

TS TRAY SUPPORT

KD SNAP-IN

1025416

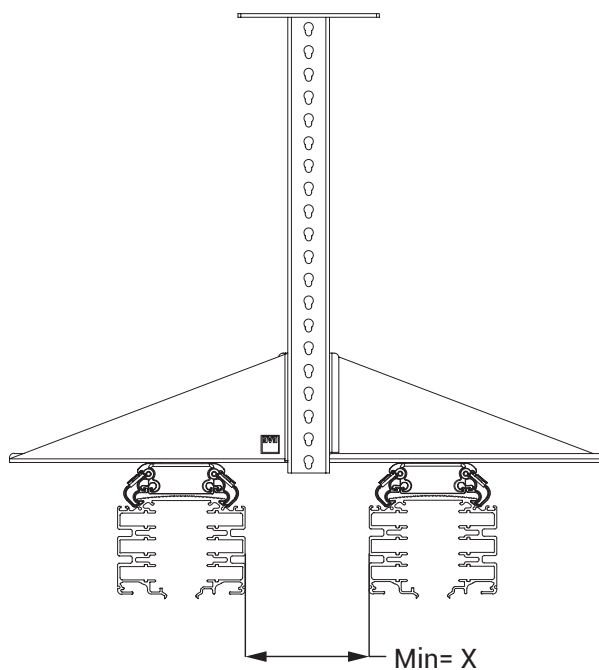



CE DECLARATION OF CONFORMITY

Product Group E-Line KD Data Rack Busbar

Manufacturer EAE Elektrik Asansor End. Insaat San. ve Tic. A.S.
Akcaburgaz Mahallesi, 3114. Sokak,
No:10 34522 Esenyurt-Istanbul-Turkey

The objects of the declaration described below is in conformity with the relevant Union harmonisation legislation. This declaration of conformity is issued under the sole responsibility of the manufacturer.

Standard:

TS EN 61439-6

Low-voltage switchgear and controlgear assemblies - Part 6: Busbar trunking systems

IEC 61439-6

Low-voltage switchgear and controlgear assemblies - Part 6: Busbar trunking systems (busways)

CE - Directive:

2014/35/EU "The Low Voltage Directive"

2014/30/EU "(EMC) Electromagnetic Compatibility Directive"

2011/65/EU "RoHS Directive"

Technical Document Preparation Official:

EAE Elektrik Asansor End. Insaat San. ve Tic. A.S.
Akcaburgaz Mahallesi, 3114. Sokak, No:10 34522 Esenyurt-Istanbul

Emre GÜRLEYEN

Date

20.04.2019

Document Authorized Signatory

Elif Gamze KAYA OK
Deputy General Manager



160A ... 800A DATA RACK BUSBAR PRODUCT OVERVIEW (E-LINE KD)

1- Standards & Certification:

- Busbar system shall be designed and manufactured as per IEC 61439-6 standard, which requires below listed tests. Each busbar rating shall have a separate type test certificate from an independent internationally accredited laboratory including below tests:
 - 10.2- Strength of material and parts, 10.2.2- Resistance to corrosion, 10.2.3- Properties of insulating materials, 10.2.3.1- Verification of thermal stability of enclosures, 10.2.3.2- Verification of resistance of insulating materials to abnormal heat and fire due to internal electric effects, 10.2.6- Mechanical impact, 10.2.7- Marking, 10.2.101- Ability to withstand mechanical loads , 10.2.101.1- Test procedure for a straight busbar trunking unit, 10.2.101.2- Test procedure for a joint, 10.2.101.3- Resistance of the enclosure to crushing, 10.3- Degree of protection of assembly, 10.4- Clearances and creepage distances, 10.5-Protection against electric shock and integrity of protective circuits, 10.5.2- Effective earth continuity between the exposed conductive parts of the assembly and the protective circuit, 10.5.3- Short-circuit withstand strength of the protective circuit, 10.9- Dielectric properties, 10.9.2- Power-frequency withstand voltage, 10.9.3- Impulse withstand voltage, 10.10- Verification of temperature rise, 10.11- Short- circuit withstand strength, Annex BB Phase conductor characteristics, Annex CC Fault-loop zero-sequences impedances, Annex DD Fault-loop resistances and reactances.
- Busbar system shall have CE marking.
- The manufacturer of busbar system shall have ISO 9001 and ISO 14001 certification.
- Each product shall have a "Type Label" including coding system, which identifies the brand, type of the unit, number of conductors and electrical details. The same coding shall be on the related certificate and catalogue.

2- Electrical Characteristics

- Busbar systems nominal insulation voltage shall be 1000 V.

2.1- Housing

- Conductors shall be packed and placed into the housing.
- Housing shall be made of thermal processed, extruded aluminium, RAL7012-Electrostatic painted.

2.2- Conductors

- Aluminium or Copper conductors overall isolated and tin plated.
- Aluminium conductors between 160A – 630A.
- Copper conductors between 250A –800A.
- Busbar system shall have the following number of conductors and wire configuration;
- 6 Conductors: (6 full size conductors CPE (100% earth conductor + double neutral + housing)),
- Phase conductors and neutral conductor shall have the same cross-section and they shall be insulated.
- Aluminium conductors shall be of EC grade aluminium. Minimum conductivity shall be 34m/mm².W.
- Copper conductors shall be minimum 99,95% electrolytic copper. Minimum conductivity shall be 56m/mm².W.

2.3- Insulation

- Insulation system shall be suitable for 1.000V continuous operation. Conductor size shall be designed so that temperature rise on the conductors shall not exceed 100°C degree at nominal current, which helps to global heating problem. With this reason, insulation class shall be selected as "B class".

2.4-Joint Structure

- Electrical and mechanical connection shall be made by placing conductor joints into the joint blocks of the connected conductors and followed by tightening and fastening of the joint bolts.

2.5-Protection

- Protection degree of the housing and joints shall be IP23D.

2.6-Acessories

- Busbar system shall have all necessary accessories (elbows, panel-transformer connections, etc.) Manufacturer shall supply special dimensioned units in short time, if the project conditions requires

3-Tap Off Boxes

- The Tap off boxes shall be Plug-nPlay type.
- Plug-n-Play tap off boxes shall be suitable to install or remove from busbars without switching off the power on the busbar.
- Plug-n-Play tap off boxes shall be suitable to install or remove anywhere alongside the busbar.
- The Tap-Off Box contacts shall be protected with a cover
- The Tap-Off contacts shall be heat cycle tested
- Contacts of plug-in tap off box shall be silver plated.
- The special locking mechanism of the Tap-Off Boxes shall ensure to carry the weight of the plug-in box and cables by the busbar housing
- While inserting the contacts of plug-in tap off box, earth contact shall make the first touch. While removing, it shall be disconnected last.
- Tap off boxes shall be manufactured of epoxy painted aluminium.
- The Tap-Off Boxes shall be equipped with a safe alignment mechanism to ensure correct installation and operation

4-Busbar Fixing&Mounting System

- The Busbars shall be easily installed and positioned through their entire lengths with the "Snap-In Fixing Units" by inserting into the guiding slots on top of the housing.
- To ensure flexible positioning of the Busbars, each single busbar length shall easily slide independently on the "Snap-In Fixing Units" through the guiding slots.
- To maintain the mounting security, the "Snap-In Fixing Unit" clamps shall be lockable.
- For various mounting practices the "Snap-In Fixing Units" shall be available with threaded rod, ceiling support and/or with tray brackets options

5-Installation and Commisioning

- Busbar systems shall be installed as per Single-Line drawings respect to required ampere rates and manufacturer installation guide (torque values, lockers, etc.). Electrical installer shall run an insulation test after installation, according to manufacturer's test procedures. The results of the test shall be reported to the manufacturer and minimum insulation value shall be 1 Mohms.

DATA RACK BUSBAR

►►Project Design Form



Item	Component List	Quantity

Company :	
Project :	
Project No :	

Prepared by	Name :
	Date :
	Signature :

Please duplicate this page for your own use.

DATA RACK BUSBAR

►►Project Design Form



Item	Component List	Quantity

Company :
Project :
Project No :

Prepared by
Name :
Date :
Signature :



Please duplicate this page for your own use.

PRODUCT TYPES

BUSBAR ENERGY DISTRIBUTION SYSTEMS



CABLE TRAYS



TROLLEY BUSBAR ENERGY DISTRIBUTION SYSTEMS



INDOOR SOLUTIONS



SUPPORT SYSTEMS



Please visit our website for the updated version of our catalogues.
www.eaeelectric.com

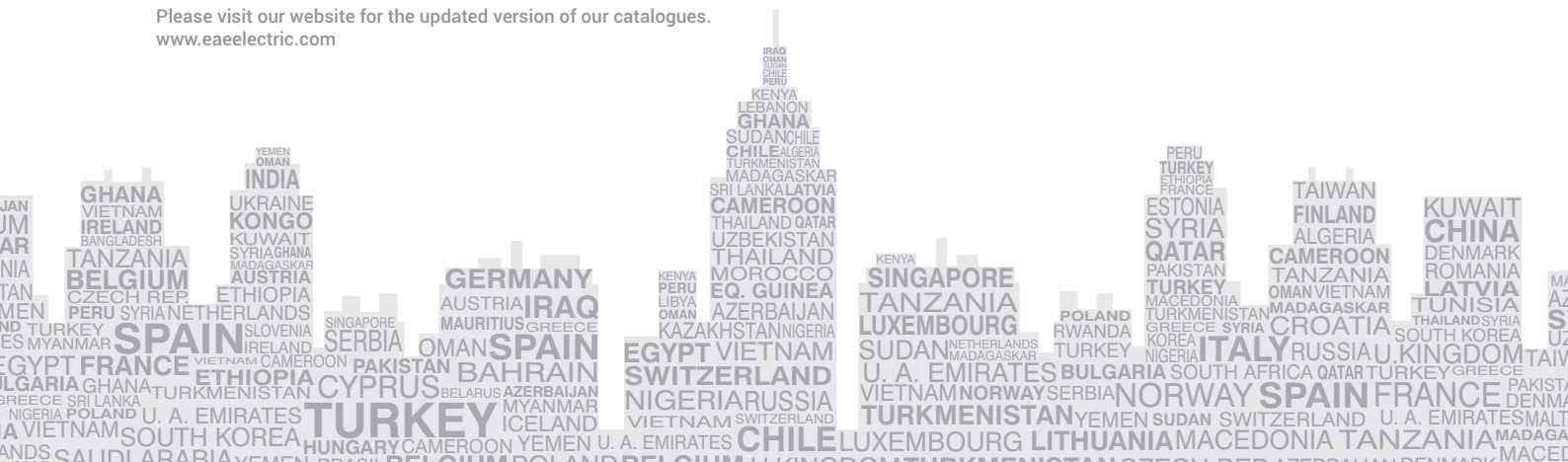

EAE Elektrik A.S.
Akcaburgaz Mahallesi,
3114. Sokak, No:10 34522
Esenyurt - Istanbul - TURKEY
Tel: +90 (212) 866 20 00
Fax: +90 (212) 886 24 20

EAE Elektrik Gebze Factory
Makine Ihtisas Organize Sanayi
Bolgesi Mahallesi, 6. Cadde,
8. Sokak, No:6 41455
Dilovası - Kocaeli - TURKEY
Tel: +90 (262) 502 05 65
Fax: +90 (262) 502 05 70

Please visit our website for the updated version of our catalogues.
www.eaelectric.com



Catalogue 55-Eng. / Rev 03 1000 Pcs. 15/02/2021
G.M.

EAE has full right to make any revisions or changes on this catalogue without any prior notice.

