



The **Saniswift drain pump** is used to pump gray water away from a variety of fixtures in **residential applications**. The system is able to discharge the waste up to **14 feet vertical and/or 140 feet horizontal**.

- **Discharges the waste through a 1" rigid pipe. A non-return valve is included** on the discharge fitting assembly provided with the system.
- Has been designed with a **1½" vent connection** on top of the lid. All plumbing codes require connection to a vent system. Either inlet located on top of the housing can be used for the vent or as an inlet. Please note that the vent system should be a two-way air vent as air needs to freely flow both ways. Note: The use of mechanical vents, air admittance valves or similar devices is not permitted.
- Discharges **gray water from a kitchen sink, shower, dishwasher, washing machine** (indirect connection via laundry sink). The gray water will drain into the system **via three 1½" inlets**, two low inlets (with built-in check valves) on either side of the housing and one on top of the enclosure.

ResidentialGrade

TECHNICAL SPECIFICATIONS

Pump type: Drain pump
Electrical: 120 V – 60 Hz / 4.5 Amps (Max)
Motor: 0.3 HP oil-filled thermally protected motor
Capacitor rating: 30 microfarad
Operating Temperature: 140 F° Max.
Power cord length: 48 inches
Noise level: ≤ 44 dBA (Lp) (measured at 3 ft.)





Discharge pipe diameter: 1"

Discharge rate at 14 ft: 18 GPM

Discharge rate at 3 ft: 24 GPM

Shut-off head: 25 ft.

Normal running time: 3-5 seconds (short bursts)

Capacity: 2.75 gallons

Inlets: 1½" (sides), 1½" vent (top)

Method of activation: Pressure switch, circuit board

Shower/bathtub base height: 6" - 8" min.

Weight: 13 lbs.

Certifying agencies: CSA (IPC, NSPC)

Recommended accessories: Descaler

Connections: Sink, shower, washing machine (indirect),
dishwasher, laundry sink, etc.

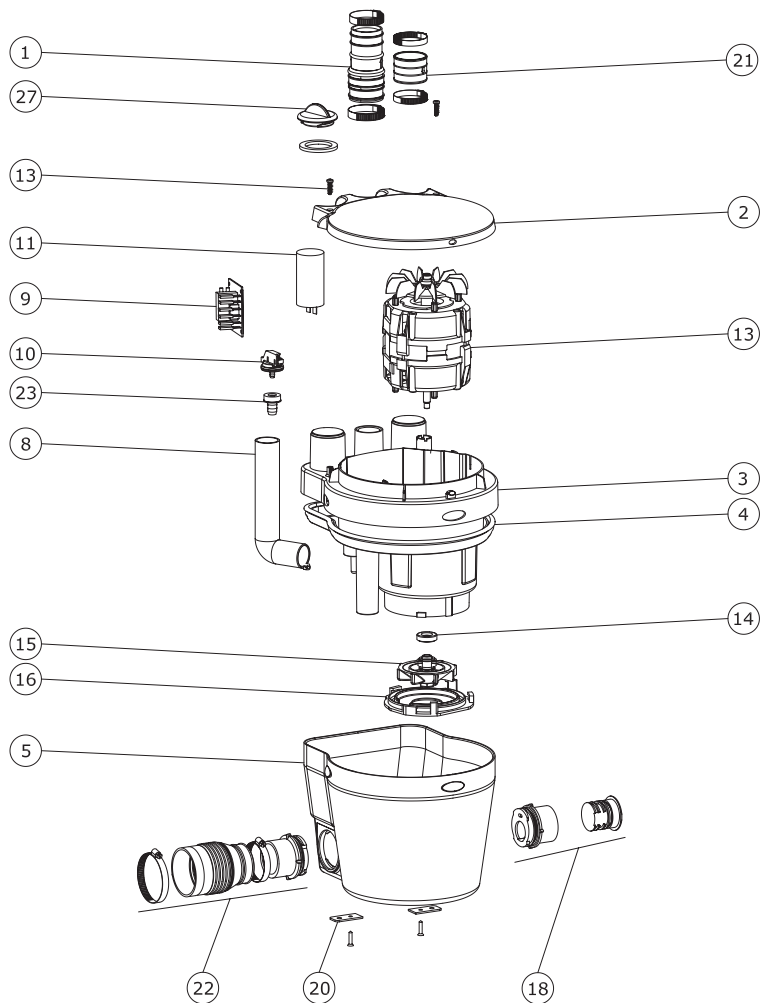
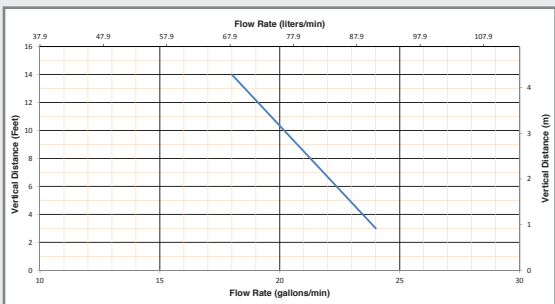
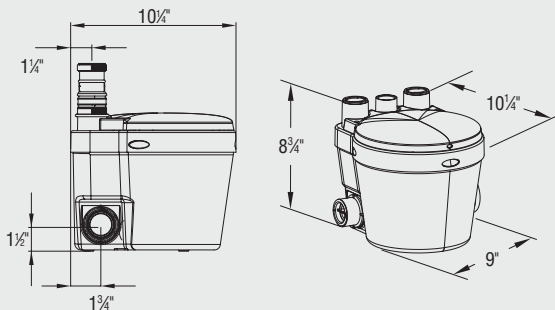

PLEASE CALL US TOLL-FREE AT 800-571-8191 (US) / 800-363-5874 (CDN)
TO PURCHASE PARTS REFERENCED ABOVE

AN EASY SOLUTION FOR A REMOTE LAUNDRY ROOM INSTALLATION OR FOR ANY GRAY WATER APPLICATION

Powerful and economical with a compact design and multiple inlets which makes it perfect for installations anywhere you can imagine.

The perfect quiet solution designed with low drain inlets which facilitate the installation of a shower in residential applications. Built-in check valves prevent any backup into the connecting fixtures.

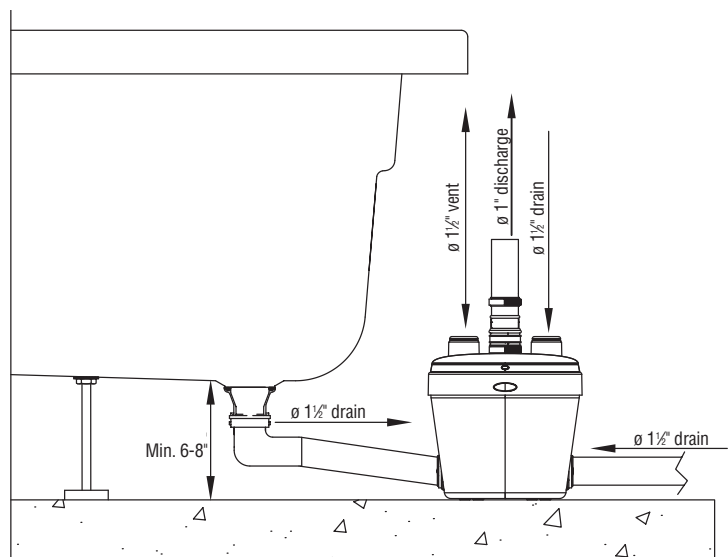

FOR ADDITIONAL TECHNICAL QUESTIONS, PLEASE CALL 800-571-8191