

The Reign TX-100-NC & XRE-100 transmitter/receiver kit is a revolutionary product. This product allows for wirelessly triggering a relay through a battery powered hand held transmitter with extreme range, no line-of-sight wireless technology.

## WHAT'S INCLUDED

There are two pieces included in the TX-100-NC to XRE-100 kit.

The Reign TX-100-NC to XRE-100 kit includes (1) TX-100-NC (transmitter) and (1) XRE-100 (receiver units).

## HOW IT WORKS...

Congratulations on your purchase of the Transmitter Solutions TX-100-NC to XRE-100 - Transmitter/Receiver kit. It has been designed with state-of-the-art radio technology to provide maximum transmission through obstruction and interference.

The TX-100-NC to XRE-100 kit can be easily paired together with the program/learn button on the XRE-100 board. Simply connect the Dry output closure to the device you are triggering and you will be up and running.

The TX-100-NC is a send/receiver unit that sends a signal when the button is pressed, indicated by a red LED light. And receives a signal back, indicated by a green LED light. This allows users to know the signal was sent and received by the corresponding XRE-100 unit.

**IMPORTANT - When using XRE to TX-100-NC, Mode Dipswitch 2 ON**

# CONTENTS:

- 1. FCC REGULATORY STATEMENT .....3
- 2. RECEIVER SPECIFICATIONS.....3
- 3. TRANSMITTER SPECIFICATIONS.....4
- 4. POWER DETAILS.....5
- 5. LED INDICATORS.....6
- 6. RELAY DIAGRAM AND WIRING.....7
- 7. DIP SWITCHES.....8
- 8. BATTERY BACKUP.....9
- 9. PAIRING IN THE FIELD.....9
- 10. TROUBLESHOOTING.....10

# 1. REGULATORY STATEMENT

FCC ID: 2ASPOXRE100A: This device complies with part 15 of the FCC rules. Operation is subject to the following two conditions: (1) This device may not cause harmful interference, and (2) this device must accept any interference received, including interference that may cause undesired operation.

**IMPORTANT!** Any changes or modifications not expressly approved by the party responsible for compliance could void the user's authority to operate this equipment.

NOTE: This equipment has been tested and found to comply with the limits for a Class B digital device, pursuant to part 15 of the FCC Rules. These limits are designed to provide reasonable protection against harmful interference in a

residential installation. This equipment generates, uses and can radiate radio frequency energy and, if not installed and used in accordance with the instructions, may cause harmful interference to radio communications. However, there is no guarantee that interference will not occur in a particular installation. If this equipment does cause harmful interference to radio or television reception, which can be determined by turning the equipment off and on, the user is encouraged to try to correct the interference by one or more of the following measures:

- Reorient or relocate the receiving antenna.
- Increase the separation between the equipment and receiver.
- Connect the equipment into an outlet on a circuit different from that to which the receiver is connected.
- Consult the dealer or an experienced radio/ TV technician for help.

## FCC Radiation Exposure Statement

This equipment complies with FCC radiation exposure limits set forth for an uncontrolled environment. This equipment should be installed and operated with minimum distance 20cm between the radiator and your body.

This transmitter must not be co-located or operating in conjunction with any other antenna or transmitter. The TX-100-NC while in use must have a separation distance of at least 20 cm from all persons, such as vehicle visor mount or wall mount, and must not be co-located or operating in conjunction with any other antenna or transmitter.

**FCC Caution:** To assure continued compliance, any changes or modifications not expressly approved by the party responsible for compliance could void the user's authority to operate this equipment. (Example – use only shielded interface cables when connecting to computer or peripheral devices).

# 2. RECEIVER SPECIFICATIONS

**Power Input:** 12-24 Volt AC/DC

**Relays:** 10A 250 VAC/ 28VDC

**12V:** 50mA (idle) 1A (transmit)

**24V:** 25mA (idle) 500ma (transmit)

**Range:** 1/2 mile (Through obstructions)

**Relays:** 10A 250 VAC/ 28VDC

**Minimum / Maximum Temperature Range:**

-40°F to 185°F (-40°C to 85°C)

**Security Encryption:** AES

**POWER INPUT: 12 to 24 VOLTS AC/DC. - 1 AMP Minimum**

**Always follow polarity when DC Power is used. Antenna Must Always be Used Regardless of Range.**

**BATTERY INPUT:** for 12 Volt Sealed Lead Acid (SLA) battery only.

Solid GREEN LED indicates battery charging. Momentarily flashing GREEN LED indicates battery is charged and a trickle/conditioning charge is occurring.

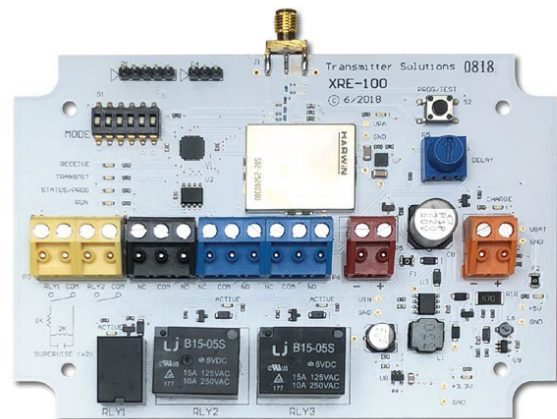

### 3. TRANSMITTER SPECIFICATIONS

Minimum / Maximum Temperature Range: -40°F to 185°F (-40°C to 85°C)

Security Encryption: AES

Range: 1/2 mile (Through obstructions)

Power: 9V Lithiom Battery

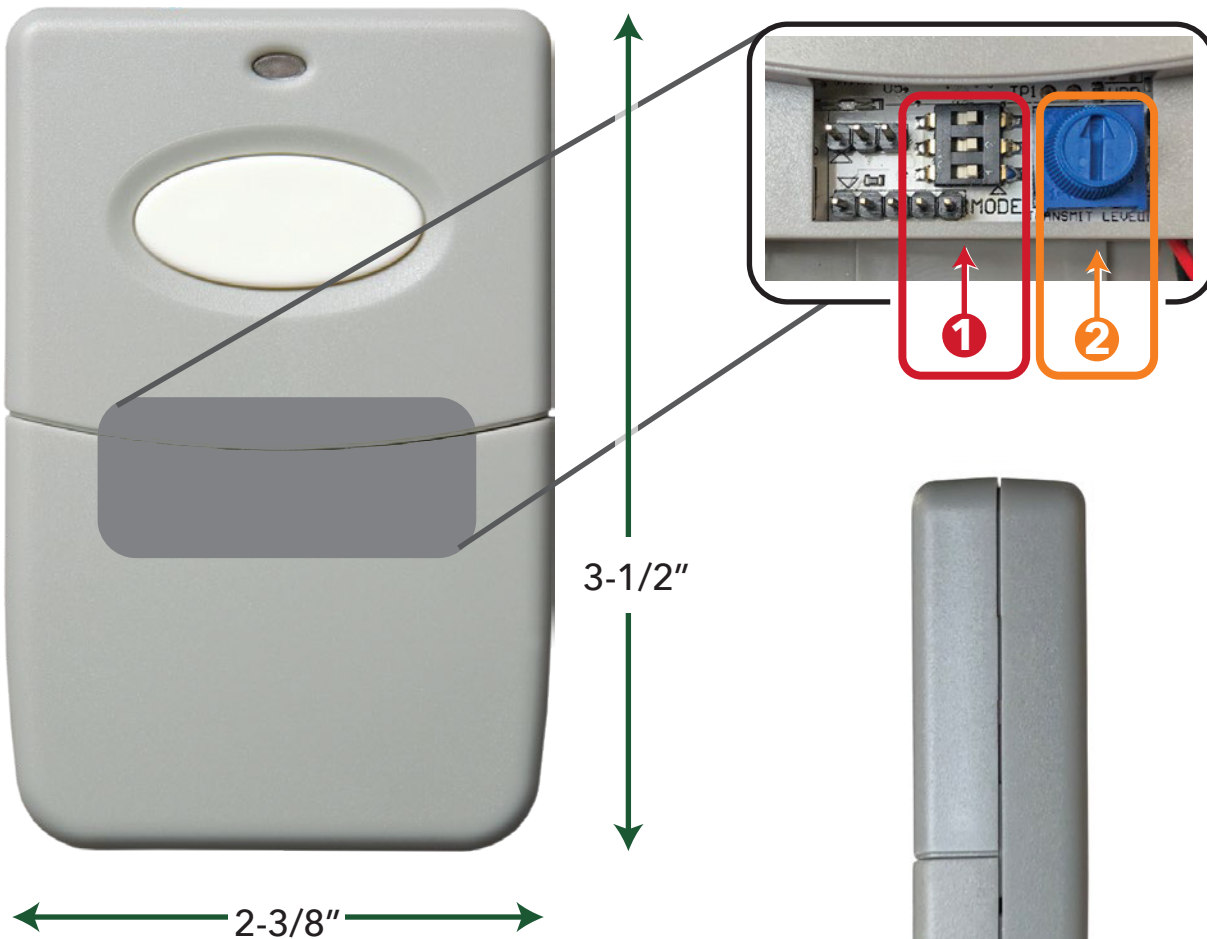

- 1** **MODE DIP SWITCHES**  
SWITCH 1 – Learn Mode  
SWITCH 2 – Not used  
SWITCH 3 – Not used

- 2** **TRANSMIT LEVEL**  
Clockwise for more power when transmitting.  
Counterclock wise for less power when transmitting.  
(Battery life will vary based on transmit power level set)

## 4. POWER DETAILS

The XRE-100 requires 1 amp of current draw to transmit at full power.

**IMPORTANT - XRE REQUIRES AT LEAST 1AMP POWER SUPPLY**

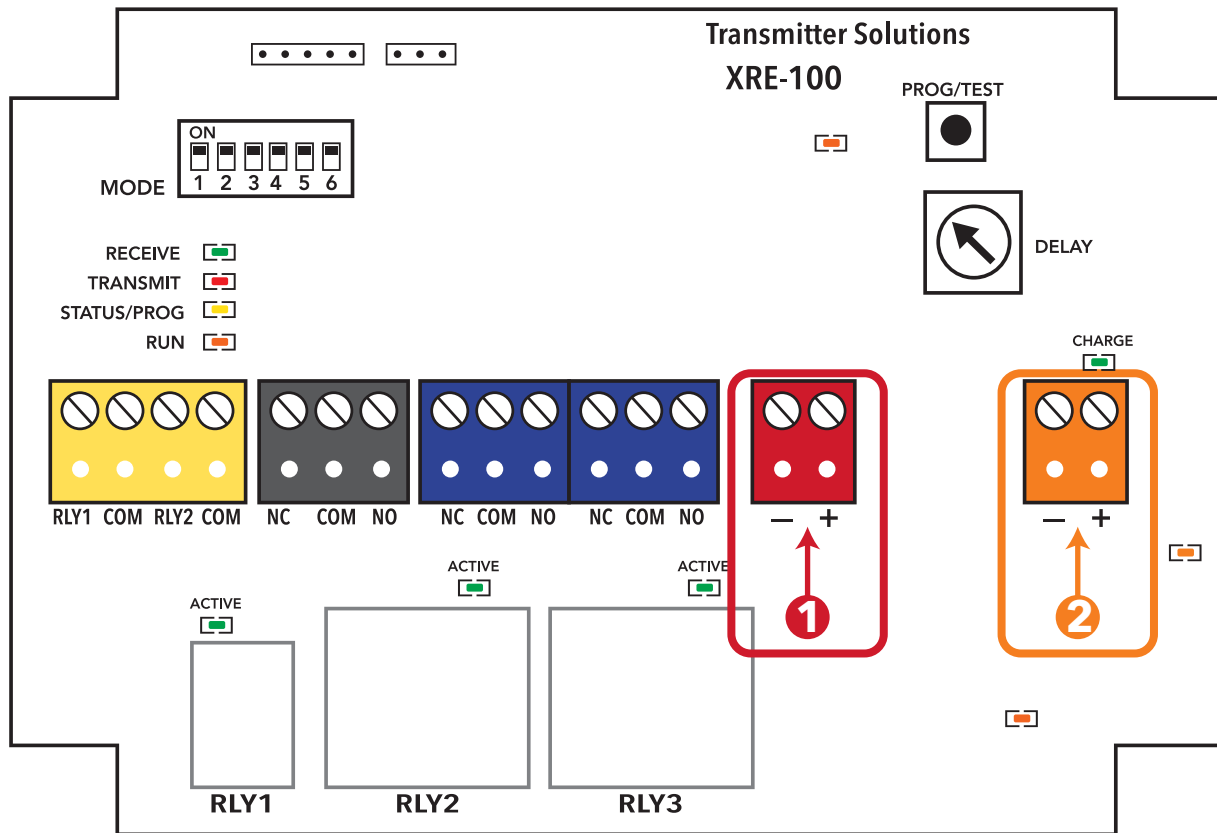

### 1 POWER INPUT:

**Power Input:** 12 to 24 VOLTS AC/DC. Always follow polarity when DC Power is used. **1 AMP Minimum**

### 2 BATTERY INPUT:

**Battery Input:** for 12 Volt Sealed Lead Acid (SLA) battery only.

Solid Green LED = Battery charging

Momentary Flashing LED = Battery is fully charged and a trickle/conditioning charge is occurring

# 5. LED INDICATORS

## STATUS LEDs:

- 1 RECEIVE** - flashes GREEN momentarily when a valid radio transmission is received.
- 2 TRANSMIT** - flashes RED momentarily when the unit transmits a packet as a result of an Relay Input change event or handshake.
- 3 STATUS/ PROG** - flashes yellow patterns indicating status of the unit: pairing, error, etc.
- 4 RUN** - flashes ORANGE 1 second ON and 1 second OFF indicating the microprocessor is running.
- 5 POWER LED** - Glows solid orange when power is present. 5 volt relay supply, 3.3 volt logic supply, and VPA 3.6 volt power amplifier supply.

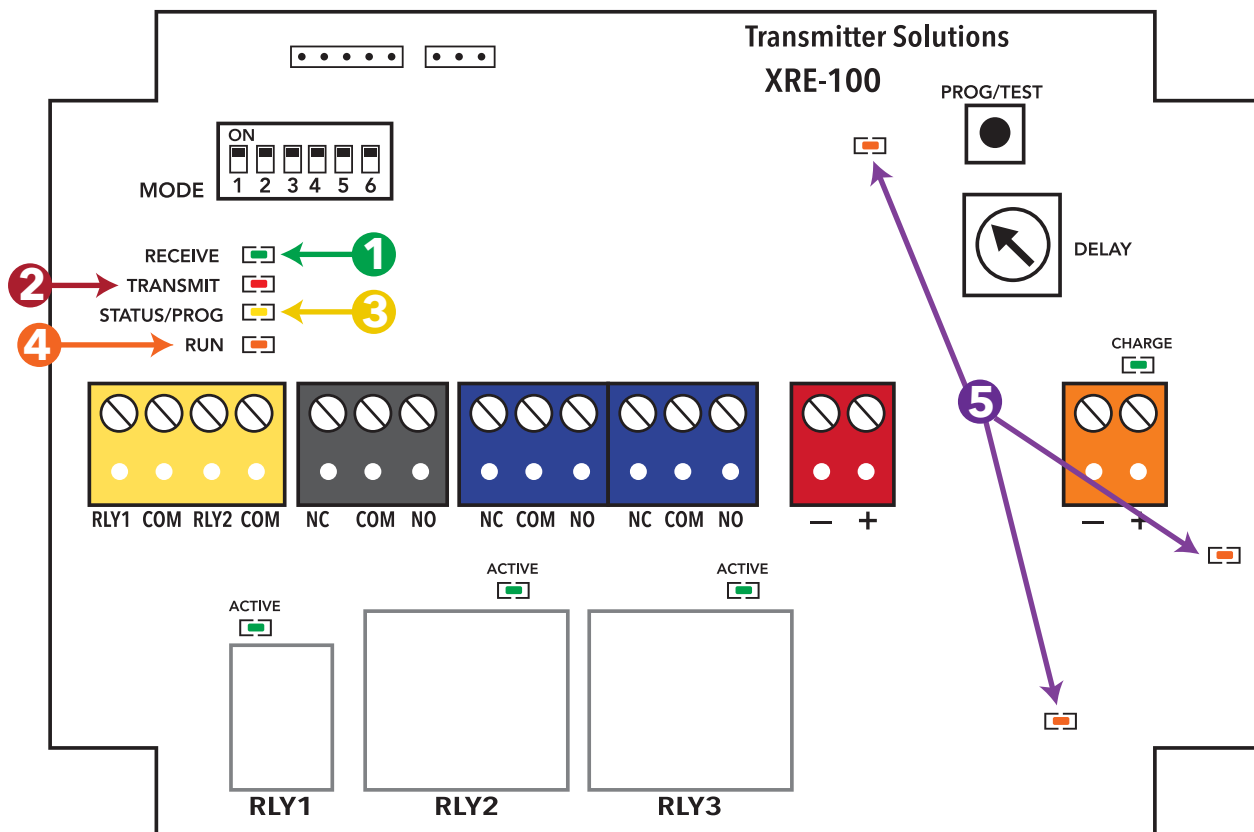

# 6. RELAY DIAGRAM AND WIRING

## 1 RELAY OUTPUTS

**Relay Outputs** - The Reign XRE-100 comes with 2-relay outputs. Relay 1 is the relay specified for use when the TX-100-NC is triggered. Relay 2 is used as a delay relay set for a certain amount of time to trigger after relay 1 is activated. Please refer to DIP switch 6 setting on page 8 for more information. The relay state is indicated by the Green ACTIVE LED above the relay.

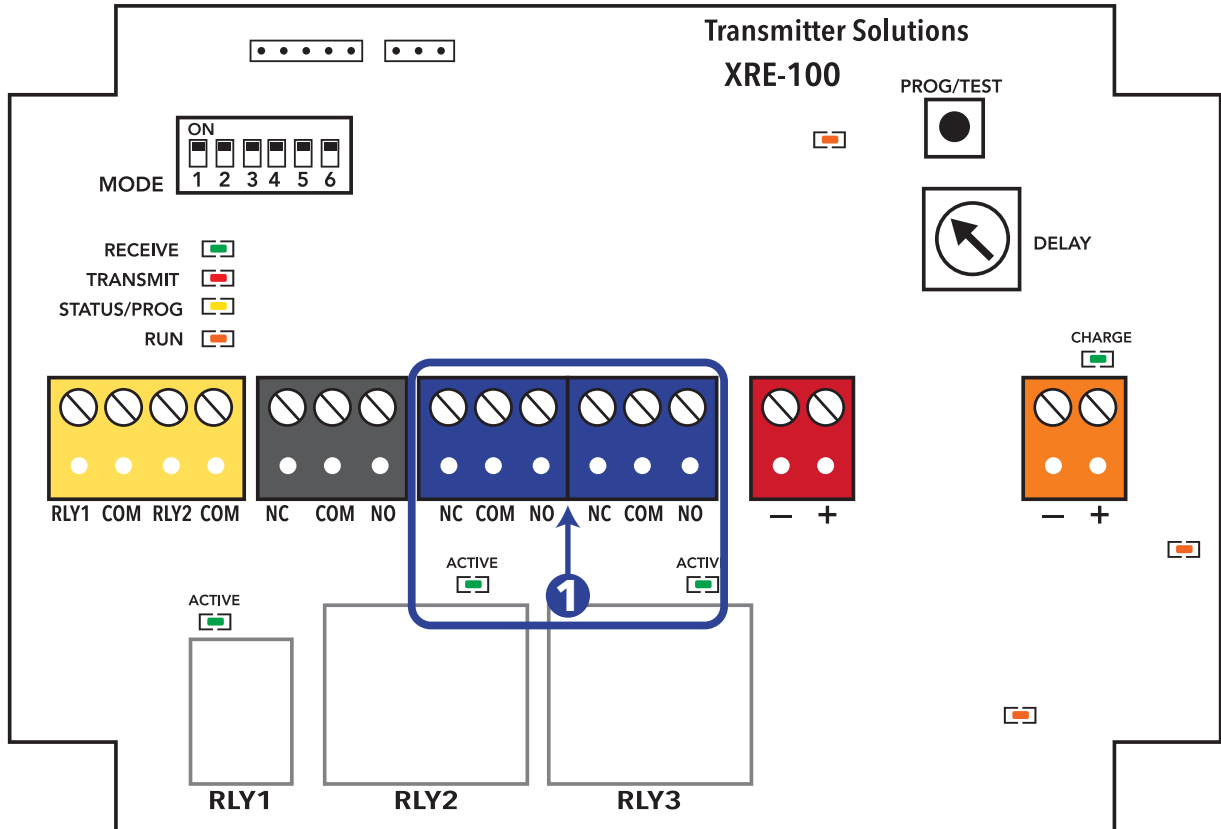

## 7. DIP SWITCHES

### 1 MODE SWITCHES

**SWITCH 1 – PROG (PAIR) – Use for programming TX-100-NC to XRE-100**

SWITCH 2 – Not used

SWITCH 3 – Not used

SWITCH 4 – Not used

The behavior of the relay(s) is controlled by Dipswitch 5 & 6.

SWITCH 5 = momentary or latching

SWITCH 6 = single or dual relays

DIPSWITCH 5	DIPSWITCH 6	FUNCTION
OFF	OFF	Relay 1 is momentary ON then OFF. Time ON is determined by RELAY DELAY potentiometer – ½ to 30 seconds. (Unlock door for RELAY DELAY time)
ON	OFF	Relay 1 is latching ON then OFF on next TX-100 transmission. (toggle)
OFF	ON	Relay 1 is momentary ON (½ sec) then Relay 2 is momentary ON (½ sec). Time between Relay 1 and Relay 2 is determined by RELAY DELAY potentiometer – ½ to 30 seconds. (Start warning then roll gate – momentary)
OFF	OFF	Relay 1 is latching ON then Relay 2 is latching ON. Time between Relay 1 and Relay 2 is determined by RELAY DELAY potentiometer. Both relays turn OFF on next TX-100 transmission. (Start warning then roll gate – latching w/ toggle)

### 2 PROGRAM/TEST BUTTON:

To program turn DIP switch 1 to the on position in both the XRE-100 and TX-100-NC. With both DIP switches turned on press the TX-100-NC transmit button.

If done correctly the XRE-100 will flash yellow status LED 3 times and TX-100 will flash green LED 3 times.

### 3 RELAY DELAY POTENTIOMETER:

Full counter clockwise is 1/2 second delay from relay 1 to relay 2 activation. Full clockwise is 10 second delay from relay 1 activation to relay 2 activation. To activate make sure DIP switch 6 is set to ON in the XRE-100.





## 10. TROUBLESHOOTING

### **TX-100-NC & XRE-100 units are not communicating:**

- 1 - Check the Run LED on the XRE-100-NC. Normal operation will be orange LED flashing once a second.
- 2 - Press the button on the TX-100-NC. When pressed, the TX-100-NC will send a radio test packet and the RED TRANSMIT LED will illuminate. If the paired XRE-100 is online, it will acknowledge with a radio test packet – indicated by a momentary on the green receive LED.





### **If you do not see the transmit and receive LED lights activate:**

- 1 - Power cycle the XRE unit.
- 2 - Move the XRE-100 unit to a higher location and avoid mounting on/in metal objects

### **If you are not getting the desired range between the TX-100 and XRE-100 unit:**

- 1 - Ensure the XRE-100 has at least 1-amp of power dedicated to itself.
- 2 - Move the XRE-100 unit to a higher location - and avoiding mounting in/on metal objects
- 3 - Check that the potentiometer on the TX-100-NC board is turned to full power. (All the way to the left)

### **XRE LED GUIDE**

RECEIVE	
TRANSMIT	
STATUS/PROG	
RUN	

## WARRANTY

The warranty period of this product is 24 months, beginning from the manufacturing date. During this period, if the product does not operate correctly, due to a defective component, the product will be repaired or replaced at the sole discretion of Transmitter Solutions. This warranty does not extend to the product casing which can be damaged by conditions outside of the control of Transmitter Solutions.

EXCEPT AS SET FORTH ABOVE, TRANSMITTER SOLUTIONS MAKES NO WARRANTIES REGARDING THE GOODS, EXPRESS OR IMPLIED, INCLUDING WARRANTY OF MERCHANTABILITY OR WARRANTY OF FITNESS FOR A PARTICULAR PURPOSE. BUYER MAKES NO RELIANCE ON ANY REPRESENTATION OF TRANSMITTER SOLUTIONS, EXPRESS OR IMPLIED, WITH REGARD TO THE GOODS AND ACCEPTS THEM "AS-IS/WHERE-IS". TRANSMITTER SOLUTIONS SELLS THE GOODS TO BUYER ON CONDITION THAT TRANSMITTER SOLUTIONS WILL HAVE NO LIABILITY OF ANY KIND AS A RESULT OF THE SALE. BUYER AGREES THAT TRANSMITTER SOLUTIONS SHALL HAVE NO LIABILITY FOR DAMAGES OF ANY KIND, WHETHER DIRECT, INCIDENTAL OR CONSEQUENTIAL DAMAGES, INCLUDING INJURIES TO PERSONS OR PROPERTY, TO BUYER, ITS EMPLOYEES OR AGENTS, AS A RESULT OF THE SALE. BUYER ALSO AGREES TO HOLD TRANSMITTER SOLUTIONS HARMLESS FROM ANY CLAIMS BUYER, OR ANY THIRD PARTY, MAY HAVE AS A RESULT OF BUYER'S USE OR DISPOSAL OF THE GOODS. BUYER HAS READ THIS DISCLAIMER AND AGREES WITH ITS TERMS IN CONSIDERATION OF RECEIVING THE GOODS.