

GIGAcontrol T

EN Translation of the Original Installation and Operating Manual



Table of contents

General Information	3
Symbols	3
Safety instructions.....	3
General.....	3
Storage	3
Operation.....	3
Type plate	4
Intended use	4
Dimensions	4
Technical data	5
Installation preparations.....	7
Safety instructions.....	7
Personal protective equipment.....	7
Safety instructions.....	8
Information on wall installation	8
Cables – for wall installation.....	8
Cables – for operators with integrated control unit.....	8
Electrical installation.....	9
Overview of the control system	9
Mains connection	10
Selecting and switching mains voltage	10
Mains feed.....	11
3-phase operation.....	11
Operation with Steinmetz circuit (capacitor)	11
Connecting the absolute encoder	12
Emergency actuation, thermal contact and slack wire switch..	12
External command initiators.....	13
Ferrite core	13
Multiple button with 6 wires.....	13
Multiple button with 4 wires.....	13
Relay for status display (X12)	13
Initial operation.....	14
DIP switches	15
(S1).....	15
LEDs on board	15
Message LED.....	15
(X1).....	15
Reset.....	16
Initial commissioning	16
Detecting motor direction	16
Defining end positions.....	17
Change the motor direction.....	17
Change the bottom end position	17
End position inaccuracy	17

General Information

Symbols



CAUTION SYMBOL:

Important safety instructions!

Caution – to ensure personal safety, it is important to observe all instructions. Save these instructions!



IMPORTANT INFORMATION SYMBOL:

Information, useful advice!

1 (1) Refers to a respective picture in the introduction or main text.

Safety instructions

General

- These installation and operating instructions must be read, understood and complied with by persons who install, use or perform maintenance on the control unit.
- Installation, connection and initial commissioning of the control unit may only be carried out by an electrician.
- The system manufacturer is responsible for the complete system. The system manufacturer must ensure that all applicable standards, directives and regulations applicable at the installation site are observed. In addition to other items, the system manufacturer must test and maintain the maximum approved closing forces in accordance with EN 12445 (Safety in use of power operated doors, test methods) and EN 12453 (Safety in use of power operated doors, requirements). The system manufacturer is responsible for preparation of technical documentation for the complete system and the documentation must accompany the system.
- All electrical wires must be fitted tightly and secured against shifting.
- The manufacturer assumes no liability for injuries, damage or breakdowns that occur due to non-compliance with the installation and operating instructions.
- Before commissioning, ensure that the mains connection matches the specifications on the type plate. If this is not the case, the control unit must not be operated.
- In case of a three-phase current connection, make sure that the motor direction is clockwise.
- Installations with a fixed mains connection require an all-phase disconnection device with appropriate fuses.
- The installation instructions must be kept within reach.
- Always ensure compliance with accident prevention regulations and current standards in each respective country.
- Take heed of and comply with the "ASR A1.7 Technical Regulations for Workplaces" of the committee for workplaces (ASTA). (Applicable for the operator in Germany, observe and comply with the applicable regulations in other countries).
- Before working on the control unit, always disconnect the power plug or disconnect the mains voltage at a main switch (lock to prevent activation).
- Regularly check power cables and wires for insulation defects or cracks. If a wiring fault is found, switch off the power immediately and repair the faulty cable or wire.
- Before switching on the power supply for the first time, make sure that the plug-in terminals are in their correct positions, otherwise the control unit may malfunction or be damaged.
- Observe the requirements of the local power supplier.
- Only use permissible fastening materials appropriate for the supporting surface.
- Only use original spare parts of the manufacturer.

Storage

- The control unit must be stored in an enclosed, dry area at a room temperature of -25 to $+65$ °C at a relative humidity of 90 % (non-condensing).

Operation

- When using the automatic close function, ensure compliance with EN 12453 (e.g. install safety devices such as photo relay).
- After installation and commissioning, all users must be instructed in the function and operation of the system. All users must be informed of the hazards and risks inherent in the system.
- Open and close the gate only if there are no persons, animals or objects within its area of movement.
- Continuously monitor the gate while it is in motion and keep all persons away from it until the gate is completely opened or closed.
- Do not drive through the door until it has been fully opened.
- The control unit must be adjusted to ensure safe operation in conformity with the standards.

General Information

Type plate

- The type plate is located on the controller housing of the operator, or if the operator is integrated, on the operator itself.
- The type plate shows the exact type designation and the date of manufacture (month/year) of the control unit.

Intended use



CAUTION! RISK OF DEATH!

All cords or straps necessary to operate the gate by hand must be removed.

- The GIGAcontrol T control unit is intended exclusively for opening and closing industrial gates, such as sectional, roller, and roller grille gates. Any other use does not constitute intended use. The manufacturer accepts no liability resulting from use other than intended use. The user bears the sole responsibility for any risk involved. It also voids the warranty.
- Only command initiators and sensors in good technical conditions may be connected, and they must be used for the intended purpose with awareness of the hazards as described by the installation and operating manual.
- Gates automated with an operator must comply with all valid standards and directives: e.g. EN 13241-1, EN 12604, and EN 12605.
- The gate must be stable and torsionally stiff, i.e. it must not bend or twist when being opened or closed.
- Only use the control unit in dry, non-explosive areas.
- The control unit conforms to the requirements of the IP-code 54. It must not be installed in areas with a corrosive atmosphere (e.g. salty air).

Dimensions

GIGAcontrol T

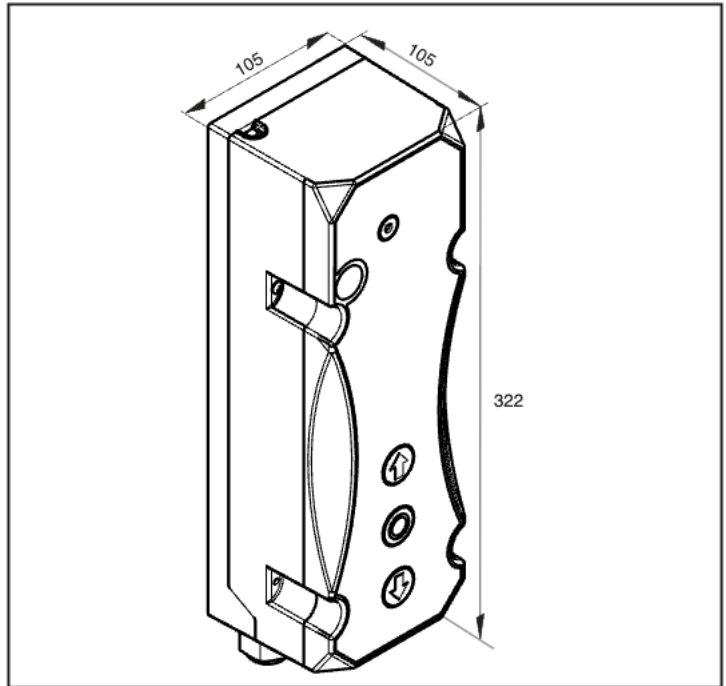

General Information

Technical data

Control unit

Dimensions	322 x 105 x 105 mm (H x W x D)
Operating voltage	1/3~230 V AC; 3~400 V AC
Mains feed fuse	3.15 A T (internal)
Control voltage	24 V DC only for internal purposes
Control voltage fuse	0.8 A T
Temperature range	-25 °C to +65 °C
Connection cross-section	1.5 mm ²
Switching capacity	0.55 kW max.
Protection class	IP54

Potential-free relay

Switching voltage	60 V DC
Switching capacity	1 A max.

General Information

Declaration of Conformity

for the installation of an incomplete machine
in accordance with the Machinery Directive 2006/42/EC, Annex II, Section 1 A

SOMMER Antriebs- und Funktechnik GmbH

Hans-Böckler-Straße 21-27
73230 Kirchheim unter Teck
Germany

hereby declares that the industrial gate control unit

GIGAcontrol T

have been developed, designed and manufactured in conformity with the

- Machinery Directive 2006/42/EC
- Low Voltage Directive 2014/35/EU
- Electromagnetic Compatibility Directive 2014/30/EU
- RoHS Directive 2011/65/EU.

The following standards were applied:

- | | |
|---------------------------------|--|
| • EN ISO 13849-1, PL "C" Cat. 2 | Safety of machines – safety-related parts of controls
– Part 1: General design guidelines |
| • EN 60335-1, where applicable | Safety of electrical appliances |
| • EN 61000-6-3 | Electromagnetic compatibility (EMC) – interference |
| • EN 61000-6-2 | Electromagnetic compatibility (EMC) – interference resistance |

The following requirements of Annex 1 of the Machinery Directive 2006/42/EC are met:

1.1.2, 1.1.3, 1.1.5, 1.2.1, 1.2.2, 1.2.3, 1.2.4, 1.2.6, 1.3.2, 1.3.4, 1.3.7, 1.5.1, 1.5.4, 1.5.6, 1.5.14, 1.6.1, 1.6.2, 1.6.3, 1.7.1, 1.7.3, 1.7.4

The special technical documentation was prepared in accordance with Annex VII Part B and will be submitted to regulators electronically on request.

The incomplete machine is intended for installation in a door system only to form a complete machine as defined by the Machinery Directive 2006/42/EC. The gate system may only be put into operation after it has been established that the complete system complies with the regulations of the above EC Directive.

The undersigned is responsible for compilation of the technical documents.

Kirchheim, den 20-04-2016



i.V.

A handwritten signature in blue ink, appearing to be 'Jochen Lude'.

Jochen Lude
Responsible for documents

Installation preparations

Safety instructions



CAUTION!

Important instructions for safe installation.
Observe all installation instructions – improper installation can lead to serious injuries!



CAUTION! RISK OF DEATH!

All cords or straps necessary to operate the gate by hand must be removed.

- Use only suitable tools.
- The mains supply line that has been provided may not be shortened or extended.
- Before commissioning, ensure that the mains connection matches the specifications on the type plate. If this is not the case, the control unit must not be operated.
- All devices to be connected externally must have a safe isolation of the contacts from the mains voltage supply according to IEC 60364-4-41.
- Cables for external devices must also be installed in accordance with IEC 60364-4-41.
- Live parts of the control unit must not be connected to the earth or with live parts or protective conductors of other electrical circuits.
- The control unit should be mounted on a low-vibration surface to eliminate vibrations that could have a negative effect on it over time (e.g., a brick wall).

Personal protective equipment

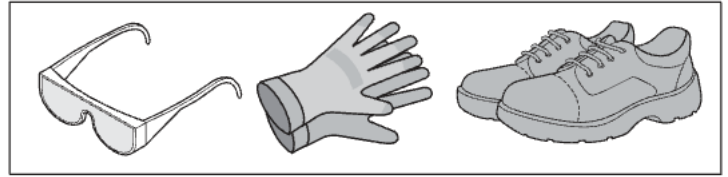

- Safety glasses (for drilling)
- Work gloves
- Safety shoes

Installation preparations

Safety instructions



CAUTION!

Important instructions for safe installation. Observe all installation instructions – improper installation can lead to serious injuries!



CAUTION!

Control or regulating units (buttons) in a fixed position must be mounted within sight of the gate. They may not, however, be mounted close to moving parts and must be at least 1.5 m above the ground.

- The operator may be installed, connected and commissioned by competent personnel only.
- Do not move the gate, if there are any people, animals or objects in the area of movement.
- Keep disabled persons and animals away from the gate.
- Wear safety glasses when drilling the fastening holes.
- Cover all drill holes to prevent ingress of dirt.
- Before opening the housing, make sure that drilling chips or any other material cannot fall into the housing.
- All electrical wires must be fitted tightly and secured against shifting.
- Before installing the control unit, inspect it for damage caused by shipping or other causes.
 - ⇒ Never install a damaged control unit. Serious injuries may result.
- Keep the system disconnected from the power supply when installing the control unit.
- Electronic components may be damaged by electrostatic discharge when touched.
 - ⇒ Do not touch the electronic components of the control unit (boards etc.).
- Close unused cable inserts with suitable material to maintain the IP-code 54.

Information on wall installation



CAUTION!

Before working on the control unit, always disconnect the power plug or disconnect the mains voltage at a main switch and lock to prevent reactivation.

- Use indoors (see data regarding temperature and IP protection class).
- The substructure must be flat and low-vibration.
- Mount the control unit housing vertically.



NOTE:

The dimensions specified here are the dimensions for drilling the fastening holes.

Housing dimensions: See the "Dimensions" section.

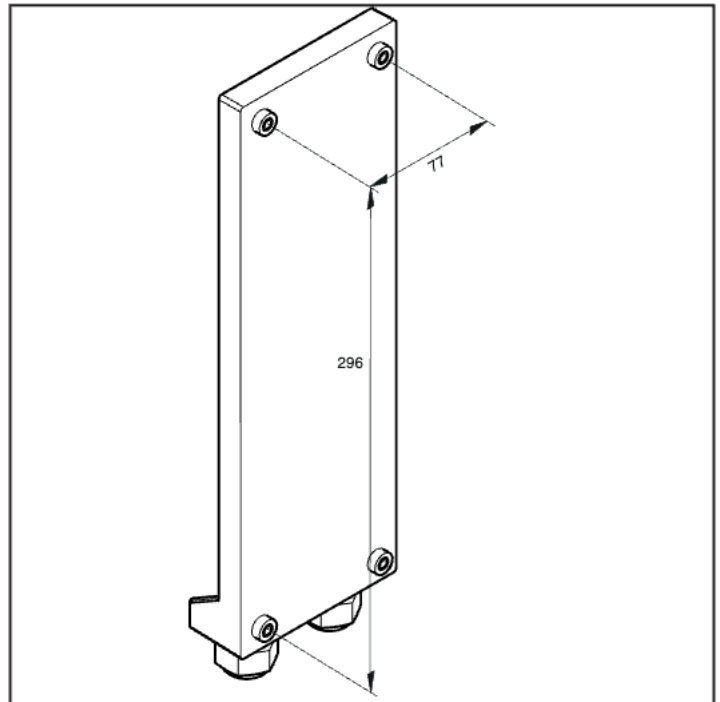

- Only use permissible fastening materials appropriate for the supporting surface.
- Attach housing to the substructure correctly.
- Use suitable tools.

Cables – for wall installation

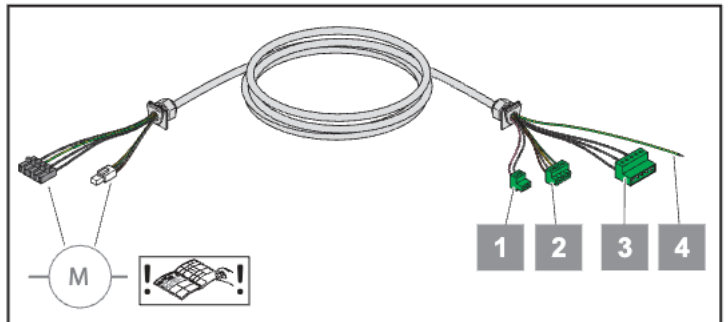

1. Safety circuit "Door stop 1" (2-pole terminal).
2. Encoder "RS485" (+/-A/B; absolute value encoder; 4-pole terminal).
3. Motor (1~230 V/3~230 V/3~400 V; 5-pole terminal).
4. Protective earth (PE).

Cables – for operators with integrated control unit

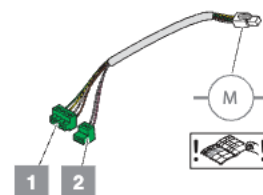

1. Safety circuit "Door stop 1" (2-pole terminal).
2. Encoder "RS485" (+/-A/B; absolute value encoder; 4-pole terminal).

Electrical installation

Overview of the control system

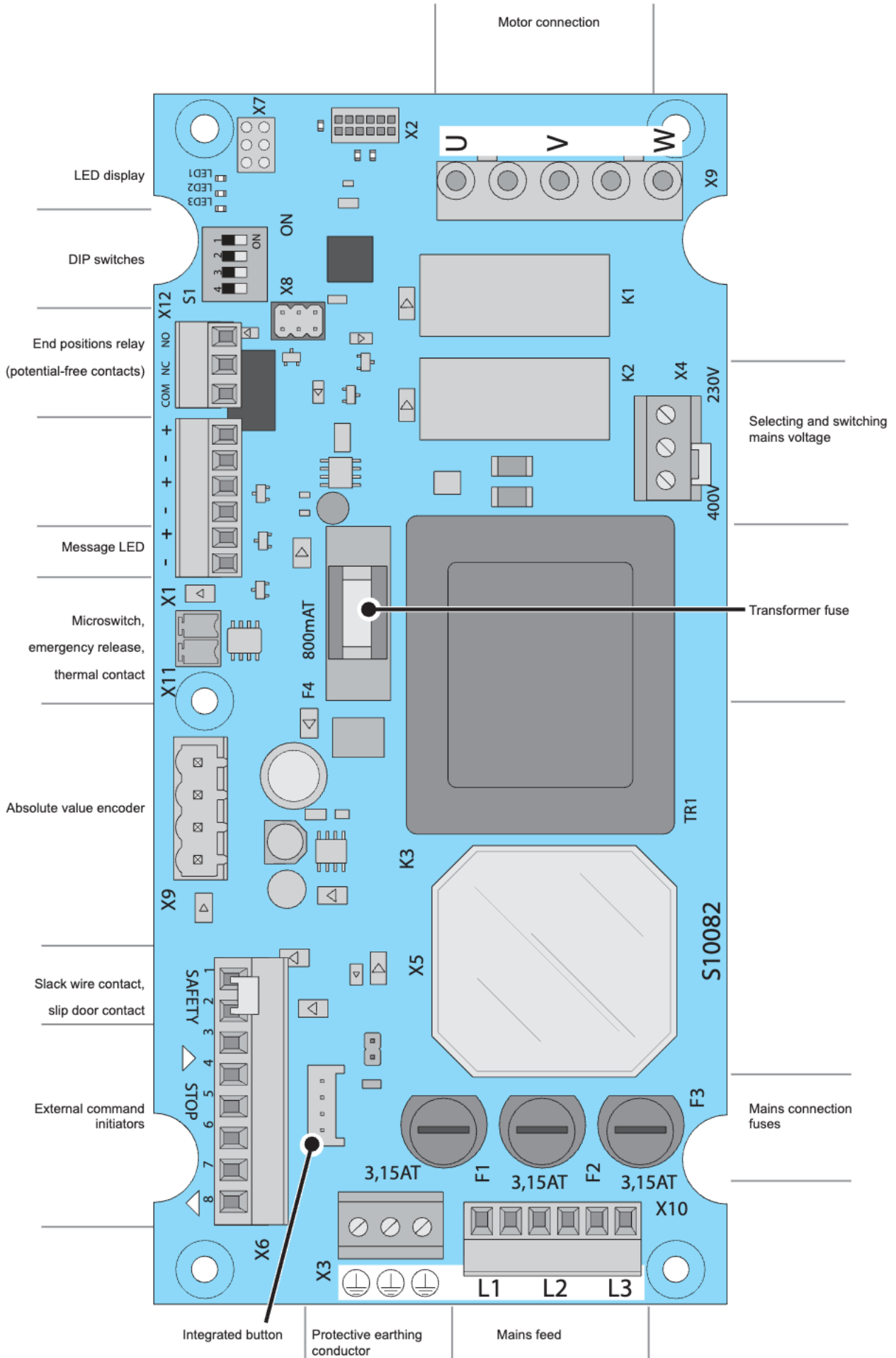

Electrical installation

CAUTION!
Electrical work must be performed by qualified electricians only.

CAUTION!
Observe the requirements of the local power supplier.

CAUTION!
The mains cable must only be replaced by the manufacturer, customer service or another electrician.

Mains connection

i **NOTE:**
The connection depends on the mains and the operator with which the control unit will be used.

The control unit is suitable for the following mains voltages: 1~230 V, 3~230 V or 3~400 V.

i **NOTE:**
Caution! Check the position of the jumper on the board before switching mains voltage. An incorrectly positioned jumper may destroy the control unit.

The control unit must be protected from short-circuit and overload by a nominal fuse value of 10 A per phase.

- A 3-pole automatic circuit breaker must be used with three-phase mains.
- A 1-pole automatic circuit breaker must be used with AC power supplies.

The control unit must have an all-phase mains circuit breaker conforming to EN 12453.

This can be:

- a plug connection (max. 1.5 m cable length)
- or
- a main switch.

i **NOTE:**
The mains circuit breaker must be easily accessible at a height between 0.6 m and 1.7 m.

The following fuses are required depending on the delivery state:

Control unit without mains plug:

Main switch, automatic circuit breaker on mains side, all poles (max. 10 A)

Control unit with 5-pole CEE plug (16 A):

16 A socket (fuse-protected with 3-pole three-phase automatic circuit breaker 3 x 10 A)

Control unit with 3-pole CEE plug:

16 A socket (fuse-protected with 1-pole automatic circuit breaker 1 x 10 A)

Selecting and switching mains voltage

i **IMPORTANT!**
It is important to ensure that the jumper on the board conforms to the actual voltage. Otherwise the board may be destroyed.

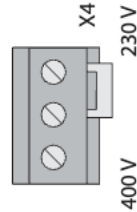

**For 1~230 V
and 3~230 V**

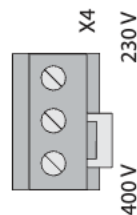

For 3~400 V

Electrical installation

Mains feed



NOTE:

If ground fault interrupters are integrated into the building installation, the control unit must not be connected unless the ground fault interrupters are class B devices (all-current-sensitive ground fault interrupters). If different types of ground fault interrupters are used, circuits may be interrupted incorrectly or not at all.

3-phase operation

3~400 V/Y

3~230 V/Δ

Motor connection

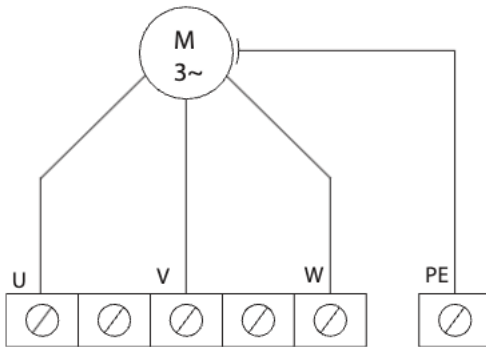

Mains connection

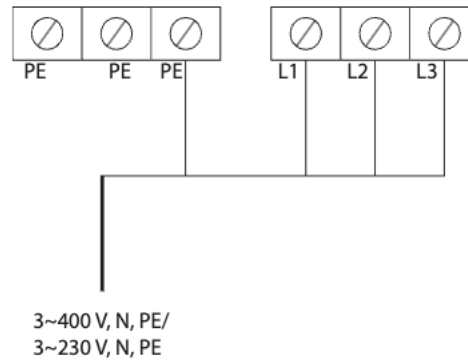

Operation with Steinmetz circuit (capacitor)

1~230 V/Δ

Motor connection

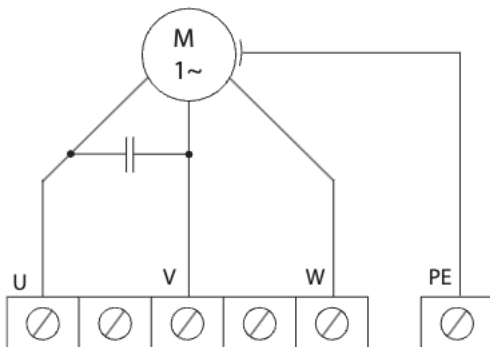

Mains connection

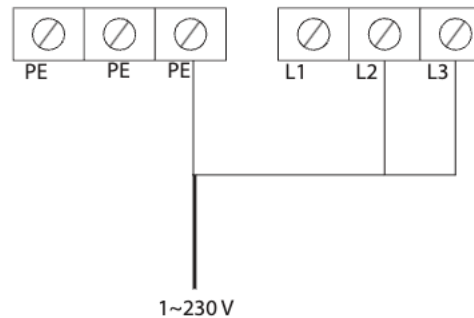

Electrical installation

Connecting the absolute encoder

Control unit

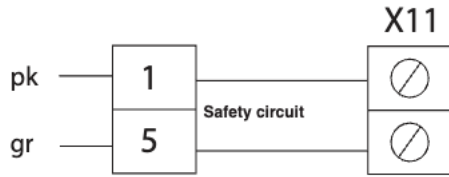
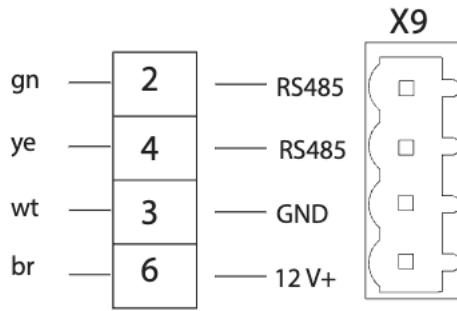

Leads in pairs.

A/B – GND/+12 V – safety circuit

Encoder

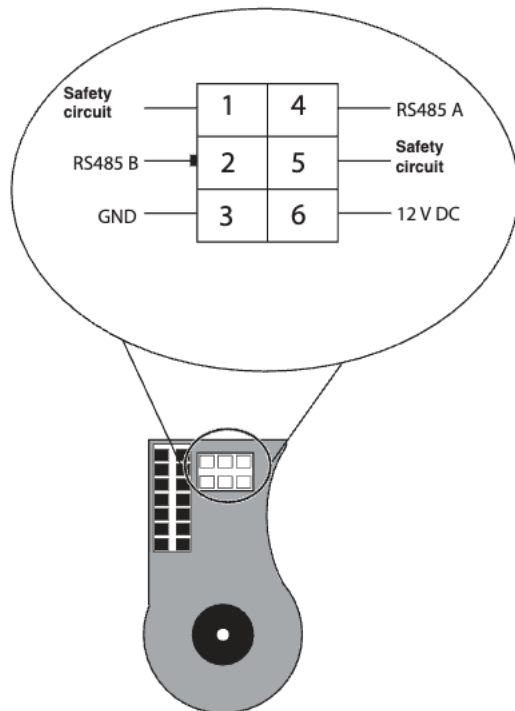

Emergency actuation, thermal contact and slack wire switch



NOTE:

If one of the devices has triggered at X11, the message LED flashes quickly (approx. 2 Hz), see chapter "Error messages".

X11 = Manual microswitch emergency actuation and thermal contact (connection with pink + grey motor cable).

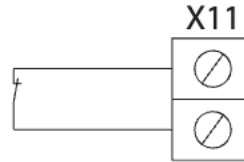

NOTE:

If one of the devices has triggered at X6, the message LED flashes quickly (approx. 2 Hz), see chapter "Error messages".

X6 = Slack wire switch (connection with spiral cable/gate socket) and slip door contact.

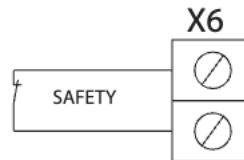

Electrical installation

External command initiators

Ferrite core



NOTE:
To prevent electromagnetic errors, the individual strands of the external command initiators must be led through the supplied ferrite core on the control unit side.

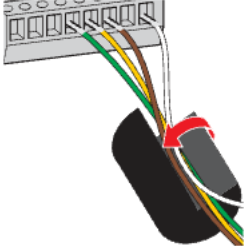

1. Bundle cables and insert in ferrite core.

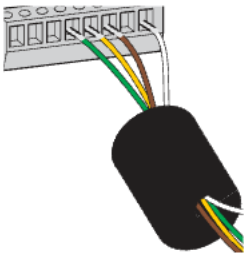

2. Close ferrite core.

Multiple button with 6 wires

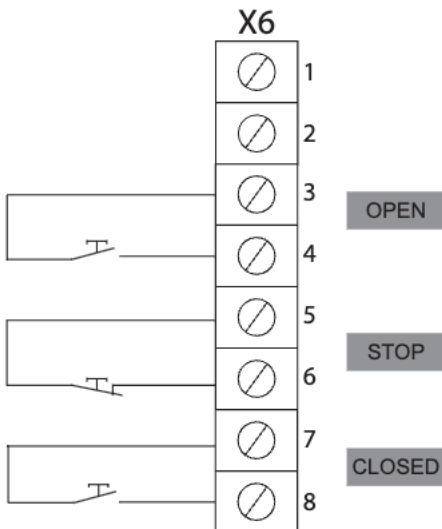

Multiple button with 4 wires

Also available from SOMMER.

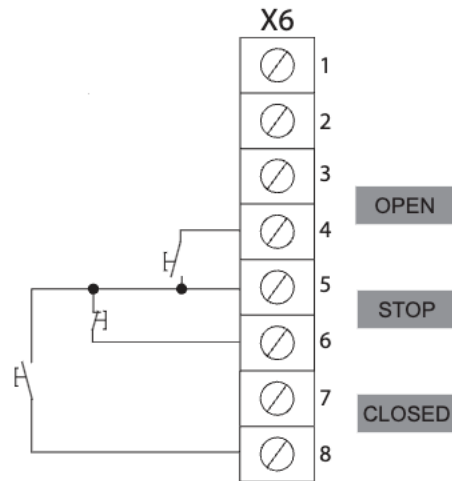

Relay for status display (X12)

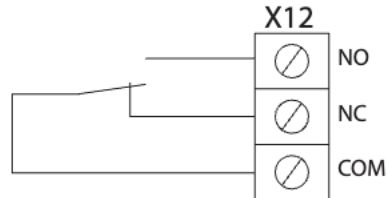

Potential-free relay

Switching voltage	60 V DC
Switching capacity	1 A max.

Initial operation

Wall mounting | wall installation

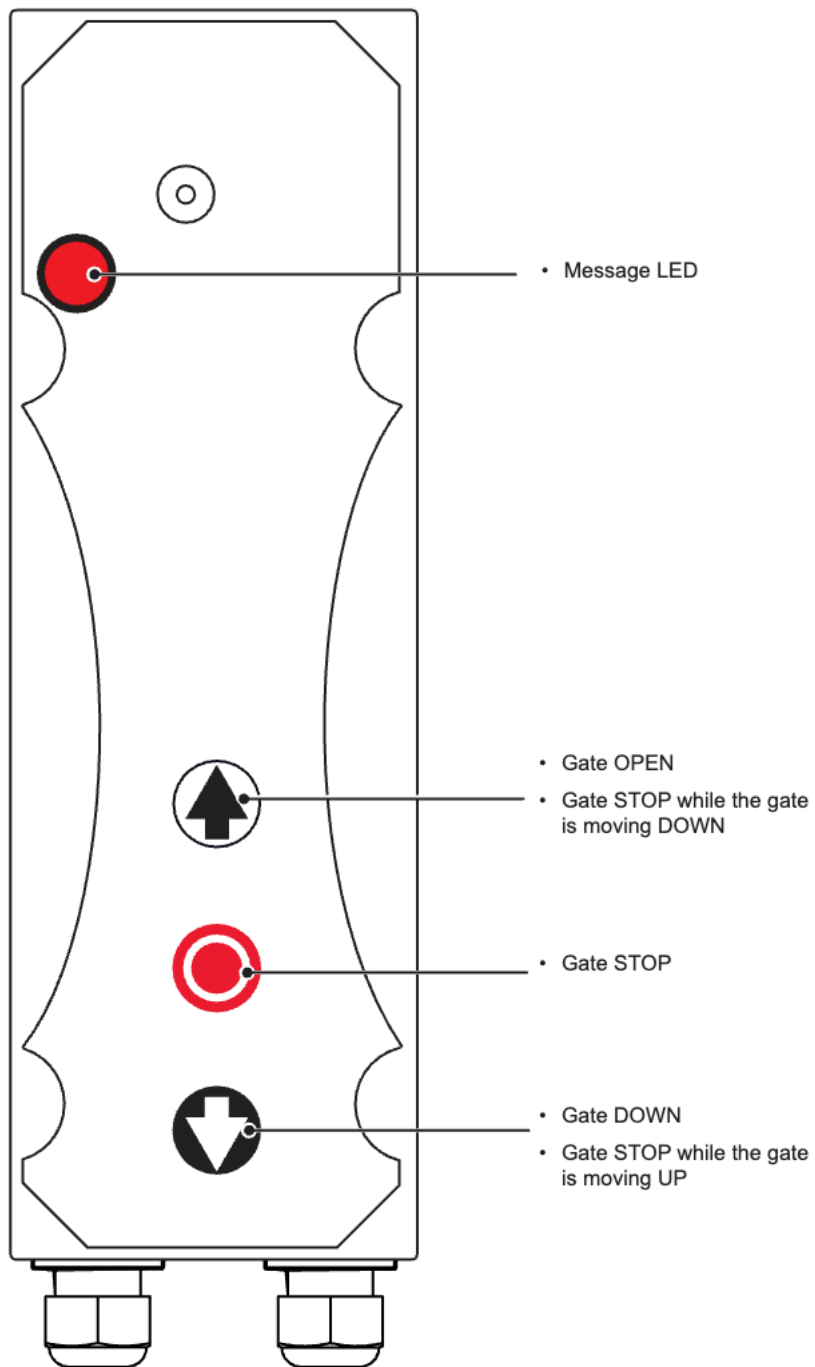

Operator with integrated control unit

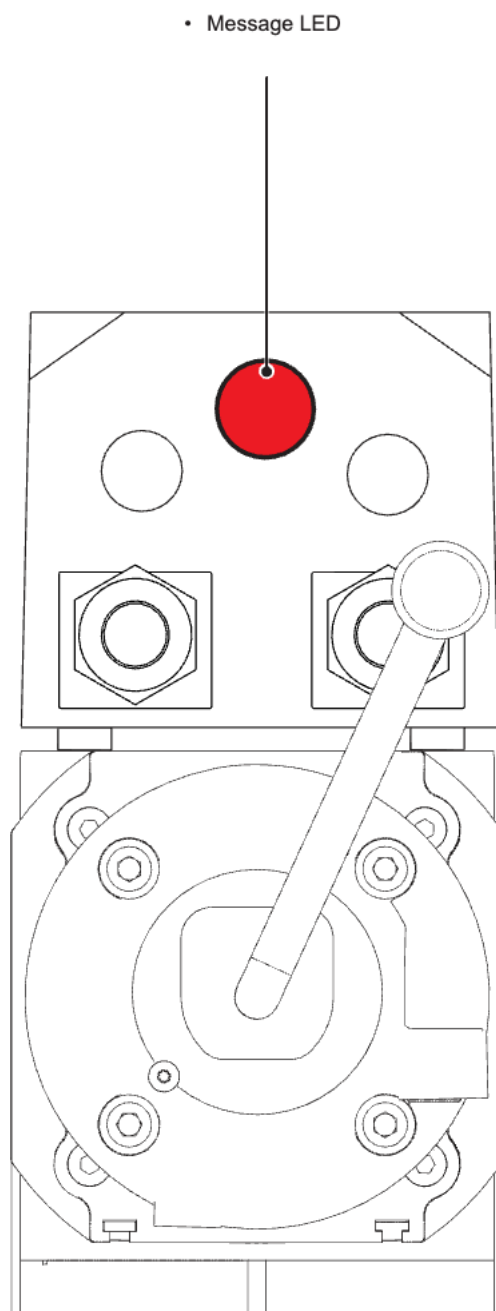

Initial operation

DIP switches

(S1)

Setting the safety limit switch range:

	100 incr.	150 incr.	200 incr.	250 incr.
DIP 1	OFF	ON	OFF	ON
DIP 2	OFF	OFF	ON	ON

Gate status display via external relay, setting of dead man function:

	Function	ON	OFF
DIP 3	Gate status display (external relay X12)	Signal in lower end position	Signal in upper end position
DIP 4	Dead man	Dead man operation in direction gate OPEN and gate CLOSE	Pulse in direction gate OPEN and dead man operation in direction gate CLOSE

LEDs on board

LED 1	Lights up while moving towards gate CLOSE
LED 2	Lights up while moving towards gate OPEN
LED 3	Flashes 1 x second when the control unit is ready for operation

Message LED

(X1)

Mode	Explanation
Continuous	Control unit is in teach-in mode for end positions
LED blinks 1 x/second	No end position programmed (factory setting)
LED blinks 2 x/second	Fault (e.g. interruption of safety circuit, end positions not programmed)
LED blinks 50 x/second	No signal from absolute encoder
LED blinks 12 x/second	Reset was successful

Initial operation

Reset

(Reset to factory settings)

1. Press and hold all three keys of the three-way keys simultaneously for about 30 seconds.
 - ⇒ Saved information on the end positions, motor direction and error messages will be deleted.
 - ⇒ After about 30 seconds, the message LED flashes very quickly (about 12 x second).
2. Release the keys.
 - ⇒ The message LED now flashes slowly (approx. 1 x/second).

Initial commissioning

The control unit has the factory settings on delivery. This means that end positions are not programmed and no information on the motor direction is stored. (See "Reset").

The control unit must be commissioned in the following sequence:

1. Detect and set the motor direction.
2. Teach-in the top end position.
3. Teach-in the bottom end position.



NOTE:

On completion of initial commissioning the end positions can be reprogrammed separately.



NOTE:

If the motor direction in item 1 must be corrected, the control unit must first be reset to the factory settings. Then the initial commissioning must be run again.

Detecting motor direction



NOTE:

Before initial commissioning can be started, the gate must be moved to the middle position. To move the gate to the middle position, it can be moved to the required position with the emergency manual actuation or moved to the required position in emergency jog mode.



NOTE:

It is important to read the complete description of initial commissioning carefully and in full and only then start commissioning to be able to complete the various commissioning steps correctly.

1. Press and hold the STOP button and the UP button simultaneously.
 - ⇒ After three seconds the motor automatically starts briefly, showing the motor direction.

A) If the motor direction is correct, i.e. in OPEN direction:

2. Continue pressing the OPEN button and the STOP button
 - ⇒ The recognition of motor direction was successful (The following (italic) steps can be skipped).

B) If the motor direction is not correct, i.e. in CLOSE direction:

3. *Release the two buttons.*
4. *Wait 3 seconds.*
5. *Press and hold the STOP button and the OPEN button simultaneously again.*
 - ⇒ *After three seconds the motor automatically starts briefly in the other motor direction, showing the motor direction.*

If the motor direction is correct, in the OPEN direction:

- ⇒ *The recognition of motor direction is successfully completed.*
- ⇒ *Continue pressing the OPEN button and the STOP button.*

If the motor direction is not correct, i.e. in the CLOSE direction:

- ⇒ *Repeat process from B).*



NOTE:

10 seconds after successful completion of recognition of motor direction (and continuously pressed OPEN and STOP buttons), the operator runs in the OPEN direction. If a button is released during the process, the operator stops.

- The process can continued within 60 seconds by pressing and holding the OPEN button and the STOP button again.

- If the process is not continued within this period, the control unit automatically resets itself, after which only jog mode is available.

Initial operation

Defining end positions



NOTE:

To ensure that any possible backlash in the gearing does not displace the end positions, the top end position should be approached from the UP direction and the bottom end position from the DOWN direction.

1. If the gate is at the desired top end position, release all buttons.
2. Press and hold the stop button for 10 seconds to confirm the end position.
 - ⇒ After 10 seconds the message LED flashes 5 times and the operator moves slightly in the DOWN direction.
 - ⇒ The message LED then remains steady.
3. To teach in the bottom end position, press and hold the CLOSE button and the STOP button simultaneously.
 - ⇒ The gate moves in the DOWN direction.
4. If the gate is at the desired bottom end position, release all buttons.
5. Press and hold the stop button for 10 seconds to confirm the end position.
 - ⇒ After 10 seconds the message LED flashes 5 times and the operator moves slightly in the UP direction.
 - ⇒ The teach-in process for the end positions is successfully completed when the message LED goes off.
 - ⇒ The control unit automatically switches to normal operation.

Initial commissioning is completed.

Change the motor direction



NOTE:

To change the motor direction permanently, the control unit must be reset and the process for "Detecting motor direction" must be run.



NOTE:

If the phases of the mains feed are changed after commissioning, the control unit detects this. The motor switches off with an error message if the UP button or the DOWN button is pressed.



NOTE:

On completion of initial commissioning the end positions can be corrected separately.

Change the top end position



NOTE:

The gate must not be in the top end position when the change mode is started. There must be sufficient travel to allow the gate to move in the UP direction.

1. To start change mode, press and hold the STOP button and the UP button simultaneously. After 10 seconds the operator starts in the UP direction.
 - ⇒ Releasing one or both buttons will cause the operator to stop – The process can be continued within 60 seconds by pressing and holding the UP button and the STOP button again.

- ⇒ If no button is pressed within this period, the program automatically switches out of teach-in mode. The former end position is retained.
2. If the gate is at the desired top end position, release all buttons.
 3. Press and hold the STOP button for 10 seconds to confirm the end position.
 - ⇒ After 10 seconds the message LED flashes 5 times and the operator moves slightly in the DOWN direction.
 - ⇒ The teach-in process for the top end position is successfully completed when the message LED goes off.
 - ⇒ The control unit automatically switches to normal operation.

Change the bottom end position



NOTE:

The gate must not be in the bottom end position when the change mode is started. There must be sufficient travel to allow the gate to move in the DOWN direction.

1. To start change mode, press and hold the STOP button and the DOWN button simultaneously. After 10 seconds the operator starts in the DOWN direction.
 - ⇒ Releasing one or both buttons will cause the operator to stop – The process can be continued within 60 seconds by pressing and holding the UP button and the STOP button again.
 - ⇒ If no button is pressed within this period, the program automatically switches out of teach-in mode. The former end position is retained.
2. If the gate is at the desired bottom end position, release all buttons.
3. Press and hold the stop button for 10 seconds to confirm the end position.
 - ⇒ After 10 seconds the message LED flashes 5 times and the operator moves slightly in the UP direction.
 - ⇒ The teach-in process for the bottom end position is successfully completed when the message LED goes off.
 - ⇒ The control unit automatically switches to normal operation.

End position inaccuracy

The control unit is fitted with automatic position correction.

If the gate after run changes, e.g. as a result of temperature variations, changes in the spring tension of sectional gates, binding as a result of mechanical damage, the control unit automatically corrects the stopping distance to the defined position value. The correction can be made as required in steps 1 to 3 gate cycles.

SOMMER Germany

SOMMER Antriebs- und Funktechnik GmbH

Hans-Böckler-Straße 21-27
73230 Kirchheim/Teck
Germany

Telephone: +49 7021 8001-0
Fax: +49 7021 8001-100

info@sommer.eu
www.sommer.eu

© Copyright 2016 All rights reserved.

