

SL3000UL SLIDE GATE OPERATOR



DATA SHEET

Section 32 31 00

Key Features

REMOTE CONTROL ACCESS

Security+ 2.0° 3-channel receiver will handle up to 50 remote controls (unlimited remotes with 811LM/813LM)

INTERNET CONNECTIVITY

myQ® technology monitors and controls the operator through the myQ app

MONITORED SAFETY INPUTS

6 inputs (main and expansion board)

DIAGNOSTIC DISPLAY

LED diagnostic display

WIRELESS DUAL-GATE COMMUNICATION

Eliminates expensive conduit costs and unsightly driveway scars

LIMIT SETTING

Mechanical

PROGRAMMABLE AUXILIARY RELAYS

Easily add additional features, such as warning lights/alarms

UNAUTHORIZED ACCESS PREVENTION

Can be programmed with anti-tailgate or quick close capabilities

HOMELINK® COMPATIBLE

Version 4 and higher

Specifications

OPERATOR SPEED

12 in. per second

POWER

120VAC single phase

ACCESSORY POWER

24VDC, 500mA output

OPERATOR WEIGHT

140 lbs.

WARRANTY

5 years commercial, 7 years residential

TEMPERATURE SPECIFICATIONS

Without heater: -4°F (-20°C) to 140°F (60°C); with optional heater: -40°F (-40°C) to 140°F (60°C)

UL USAGE CLASSIFICATION

UL 325 & UL 991 listed – class I, II, III and IV

Construction

MOTOR

High-temperature (1/2 HP or 1 HP) AC motor with class H insulation for high cycle, high-temperature applications

OPERATOR DUTY RATING

Continuous duty

CHASSIS/FRAME

Constructed with 1/4 in. gold zinc plated steel for rust prevention

GEAR REDUCTION

30:1 worm gear reducer in synthetic oil bath

CHAIN

#41 black oxide (50 ft. included)

COVER

High-density UV resistant one piece polyethylene plastic for excellent heat and corrosion resistance

RECOMMENDED CAPACITIES

1/2 HP rated for gates up to 50 ft. in length or weighing up to 1,000 lbs.
1 HP rated for gates up to 50 ft. in length or weighing up to 2,000 lbs.

Accessories

Important: Use only LiftMaster monitored entrapment protection devices itemized on the accessory page of the operators installation manual.



LiftMaster

POWERED BY myQ

SL3000UL SLIDE GATE OPERATOR

Section 32 31 00



DATA SHEET

Dimensions

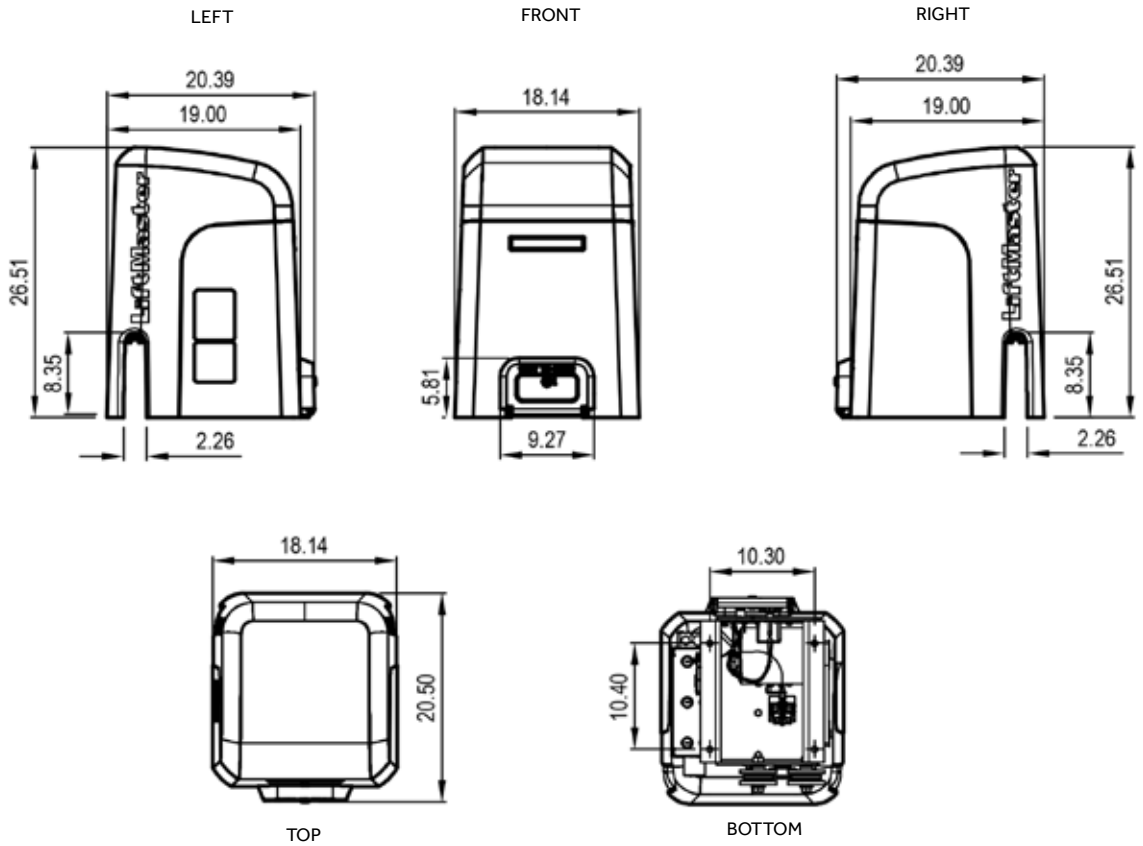

Capacity

