



**SEA**<sup>®</sup> USA  
ELECTRONIC  
OPENING  
SYSTEMS  
International registered trademark n. 2.777.971

# ORION BOX 24V



## INSTALLATION MANUALS AND SAFETY INFORMATION

SEA USA Inc.

## IMPORTANT SAFETY INFORMATION

### GENERAL SAFETY PRECAUTIONS

The following precautions are an integral and essential part of the product and must be supplied to the user Read them carefully as they contain important indications for the safe installation, use and maintenance.

1. These instruction must be kept and forwarded to all possible future users of the system.
2. This product must be used only for that which it has been expressly designed.
3. Any other use is to be considered improper and therefore dangerous.
4. The manufacturer cannot be held responsible for possible damage caused by improper, erroneous or unreasonable use.
5. Avoid operating in the proximity of the hinges or moving mechanical parts.
6. Do not enter the path of the moving gate while in motion.
7. Do not obstruct the motion of the gate as this may cause a situation of danger.
8. Do not allow children to play or stay within the path of the moving gate.
9. Keep remote control or any other control devices out of the reach of children, in order to avoid possible involuntary activation of the gate operator.
10. In case of break down or malfunctioning of the product, disconnect from the main power source.  
Do not attempt to repair or intervene directly, contact only qualified personnel for repair.
11. Failure to comply with the above may create a situation of danger.
12. All cleaning, maintenance or repair work must be carried out by qualified personnel.
13. In order to guarantee that the system works efficiently and correctly it is important to have the manufacturer's instructions on maintenance of the gate and operator carried out by qualified personnel.
14. In particular, regular checks are recommended in order to verify that the safety devices are operating correctly.

All installation, maintenance and repair work must be documented and made available to the user.

### IMPORTANT SAFETY INSTRUCTIONS

**⚠ WARNING – To reduce the risk of injury or death:**

1. READ AND FOLLOW ALL INSTRUCTIONS.
2. Never let children operate or play with gate controls. Keep the remote control away from children.
3. Always keep people and objects away from the gate. NO ONE SHOULD CROSS THE PATH OF THE MOVING GATE.
4. Test the gate operator monthly. The gate MUST reverse on contact with a rigid object or stop when an object activates the non-contact sensors. After adjusting the force or the limit of travel, retest the gate operator. Failure to adjust and retest the gate operator properly can increase the risk of injury or death.
5. Use the emergency release only when the gate is not moving
6. KEEP GATES PROPERLY MAINTAINED. Read the owner's manual. Have a qualified service person make repairs to gate hardware.
7. The entrance is for vehicles only. Pedestrians must use separate entrance.
8. Every gate operator installation MUST have secondary protection devices against entrapments, such as edge sensors and photo beams more in particular in places where the risk of entrapments is more likely to occur
9. SAVE THESE INSTRUCTIONS

### PERIODICAL MAINTENANCE

#### TURNING OFF THE POWER

Clean and grease parts in movement (wheels, counter-connecting rod, release, etc.)	Annual
Check for corroded parts and replace if necessary	Annual
Check if the screws and all mounting hardwares are properly tighten	Annual
Check the conditions of wear and tear of the devices in movement	Annual
Check the correct drain of the rainwater	Annual
Check the integrity of the connection cables	Annual
Inspect the track for any signs of cracking or separation	Annual
Ensure that the gate moves freely	Annual

<b>BY MAIN POWER SOURCE TURNED OFF</b> Check the battery conditions and be sure that connections are free of corrosion Verify the functionality of the battery backup, or power failure option	Annual
--	--------

#### TURNING ON THE POWER

Check and confirm the proper operation of all safety devices (photocells, edge sensors etc)	Annual
Check and confirm the operation of all installed accessories	Annual
Check and confirm the operation of the manual release	Annual

**All the above described operations must be made exclusively by an authorized installer**



## **GENERAL SAFETY INFORMATION**

An appliance shall be provided with an instruction manual. The instruction manual shall give instructions for the installation, operation, and user maintenance of the appliance.

The installation instructions shall specify the need for a grounding-type receptacle for connection to the supply and shall stress the importance of proper grounding.

The installation instructions shall inform the installer that permanent wiring is to be employed as required by local codes, and instructions for conversion to permanent wiring shall be supplied.

Information shall be supplied with a gate operator for:

- a) The required installation and adjustment of all devices and systems to effect the primary and secondary protection against entrapment (where included with the operator).
- b) The intended connections for all devices and systems to effect the primary and secondary protection against entrapment. The information shall be supplied in the instruction manual, wiring diagrams, separate instructions, or the equivalent.

### **Vehicular gate operators (or systems)**

A vehicular gate operator shall be provided with the information in the instruction manual that defines the different vehicular gate operator Class categories and give examples of each usage. The manual shall also indicate the use for which the particular unit is intended as defined in Glossary, Section 3. The installation instructions for vehicular gate operators shall include information on the Types of gate for which the gate operator is intended.

A gate operator shall be provided with the specific instructions describing all user adjustments required for proper operation of the gate. Detailed instructions shall be provided regarding user adjustment of any clutch or pressure relief adjustments provided. The instructions shall also indicate the need for periodic checking and adjustment by a qualified technician of the control mechanism for force, speed, and sensitivity.

Instructions for the installation, adjustment, and wiring of external controls and devices serving as required protection against entrapment shall be provided with the operator when such controls are shipped with the operator.

Instructions regarding intended installation of the gate operator shall be supplied as part of the installation instructions or as a separate document. The following instructions or the equivalent shall be supplied where applicable:

## **IMPORTANT INSTALLATION INSTRUCTIONS**

a) Install the gate operator only when:

- 1) The operator is appropriate for the construction of the gate and the usage Class of the gate,
- 2) All openings of a horizontal slide gate are guarded or screened from the bottom of the gate to a minimum of 4 feet (1.22 m) above the ground to prevent a 2-1/4 inch (57.2 mm) diameter sphere from passing through the openings anywhere in the gate, and in that portion of the adjacent fence that the gate covers in the open position,
- 3) All exposed pinch points are eliminated or guarded, and
- 4) Guarding is supplied for exposed rollers.

b) The operator is intended for installation only on gates used for vehicles. Pedestrians must be supplied with a separate access opening. The partial access opening shall be designed to promote pedestrian usage. Locate the gate such that persons will not come in contact with the vehicular gate during the entire path of travel of the vehicular gate.

c) The gate must be installed in a location so that enough clearance is supplied between the gate and adjacent structures when opening and closing to reduce the risk of entrapment. Swinging gates shall not open into public access areas.

d) The gate must be properly installed and work freely in both directions prior to the installation of the gate operator. Do not over-tighten the operator clutch or pressure relief valve to compensate for a damaged gate.

e) The gate operator controls must be placed so that the user has full view of the gate area when the gate is moving and **AWAY FROM THE GATE PATH PERIMETER**.

f) Controls intended for user activation must be located at least six feet (6') away from any moving part of the gate and where the user is prevented from reaching over, under, around or through the gate to operate the controls. Outdoor or easily accessible controls shall have a security feature to prevent unauthorized use.

g) The Stop and/or Reset button must be located in the line-of-sight of the gate. Activation of the reset control shall not cause the operator to start.

h) A minimum of two (2) **WARNING SIGNS** shall be installed, one on each side of the gate where easily visible

**i) For gate operators utilizing a non-contact sensor:**

- 1) See instructions on the placement of non-contact sensors for each Type of application
- 2) Care shall be exercised to reduce the risk of nuisance tripping, such as when a vehicle, trips the sensor while the gate is still moving
- 3) One or more non-contact sensors shall be located where the risk of entrapment or obstruction exists, such as the perimeter reachable by a moving gate or barrier

**j) For a gate operator utilizing a contact sensor:**

- 1) One or more contact sensors shall be located where the risk of entrapment or obstruction exists, such as at the leading edge, trailing edge, and postmounted both inside and outside of a vehicular horizontal slide gate.
- 2) One or more contact sensors shall be located at the bottom edge of a vehicular vertical lift gate.
- 3) One or more contact sensors shall be located at the pinch point of a vehicular vertical pivot gate.
- 4) A hardwired contact sensor shall be located and its wiring arranged so that the communication between the sensor and the gate operator is not subjected to mechanical damage.
- 5) A wireless contact sensor such as one that transmits radio frequency (RF) signals to the gate operator for entrapment protection functions shall be located where the transmission of the signals are not obstructed or impeded by building structures, natural landscaping or similar obstruction. A wireless contact sensor shall function under the intended end-use conditions.
- 6) One or more contact sensors shall be located on the inside and outside leading edge of a swing gate. Additionally, if the bottom edge of a swing gate is greater than 6 inches (152 mm) above the ground at any point in its arc of travel, one or more contact sensors shall be located on the bottom edge.
- 7) One or more contact sensors shall be located at the bottom edge of a vertical barrier (arm).

Instruction regarding intended operation of the gate operator shall be provided as part of the user instructions or as a separate document. The following instructions or the equivalent shall be provided

**NOTICE**

As for misunderstandings that may arise refer to your area distributor or call our help desk. These instructions are part of the device and must be kept in a well known place. The installer shall follow the provided instructions thoroughly. SEA products must only be used to automate doors, gates and wings. Any initiative taken without SEA USA Inc. explicit authorization will preserve the manufacturer from whatsoever responsibility. The installer shall provide warning notices on not assessable further risks. SEA USA Inc. in its relentless aim to improve the products, is allowed to make whatsoever adjustment without giving notice. This doesn't oblige SEA to up-grade the past production. SEA USA Inc. can not be deemed responsible for any damage or accident caused by product breaking, being damages or accidents due to a failure to comply with the instructions herein. The guarantee will be void and the manufacturer responsibility will be nullified if SEA USA Inc. original spare parts are not being used. The electrical installation shall be carried out by a professional technician who will release documentation as requested by the laws in force. Packaging materials such as plastic bags, foam polystyrene, nails etc must be kept out of children's reach as dangers may arise.

**To respect the norms in force it is recommended to use the ENCODER SYSTEM together with the electronic control units**

**Changes to UL 325 ED. 6th for Gate Operators**

Starting on Jan. 12, 2016, new UL 325 changes take effect, bringing a series of new mandates for the gate operator industry. Here's a quick guide to the key modifications.

**1. Entrapment-Protection Devices.** Gate operators are required to have a minimum of two independent means of entrapment protection where the risk of entrapment or obstruction exists. A manufacturer can use two inherent-type systems, two external-type systems, or an inherent and an external system to meet the requirement. However, the same type of device cannot be used for both means of protection.

**2. Monitoring Required.** An external non-contact sensor or contact sensor may be used as a means of entrapment protection. However, the sensor must be monitored once every cycle for (1) the correct connection to the operator and (2) the correct operation of the sensor.

If the device is not present, not functioning, or is shorted, then the gate operator can only be operated by constant pressure on the control device. Portable wireless controls will not function in this case.

**3. Entrapment Risk Identification.** As in the past, it's up to the installer to examine the installation and determine where a risk of entrapment or obstruction exists. Manufacturers are required to provide instructions for the placement of external devices, but they give only examples of suggested entrapment protection in their installation manuals. If the installer identifies a risk of entrapment or obstruction, at least two independent means of entrapment protection are required.

**4. Terminology Change.** The terms "primary" and "secondary" have been removed in the description of entrapment protection devices. This was done to emphasize that all entrapment protection devices are equally important.

**5. The End of Type E.** Type E (audible alarm) devices can no longer be used for entrapment protection. This change was made because the Type E device is really a warning device, not an entrapment-protection device. Also, all gate operator classes are now required to have an audio alarm that sounds when two successive obstructions are encountered via a contact-type system.

**6. Access Control Location for Emergency Use.** An exception has been added in the manufacturer’s instructional requirements for the location of controls that operate the gate. The instructional requirements state that these controls must be at least 6' away from any moving part of the gate. In the new exception, “Emergency access controls only accessible by authorized personnel (e.g., fire, police, EMS) may be placed at any location in the line-of-sight of the gate.”

**7. Barrier-Arm Operator Exception.** An exception has changed for barrier-arm gate operators requiring entrapment protection. The previous exception stated that a barrier-arm operator did not require entrapment protection if the arm did not move toward a rigid object closer than 2'. The distance has been reduced to 16" so it more closely aligns with the industry-defined entrapment protection provisions in ASTM F2200.

**8. Gate Operator Class II and Class III Definitions.** The definitions for installation classes for gate operators were modified. Class II now includes commercial locations *accessible* to the general public. Class III was refined to specify industrial locations *not accessible* to the general public. These changes, while seemingly minor, may affect which gate operator is suitable for a particular installation location.

## **UL 325 ED. 6th ENTRAPMENT PROTECTION REQUIREMENTS**

### **VEHICULAR GATE OPERATOR CLASSES**

**Residential Vehicular Gate Operator-Class I:** A vehicular gate operator (or system) intended for use in garages or parking areas associated with a residence of one-to-four single families

**Commercial/General Access Vehicular Gate Operator-Class II:** A vehicular gate operator (or system) intended for use in a commercial location or building such as a multi-family housing unit (five or more single family units), hotel, garages, retail store, or other buildings accessible by or servicing the general public

**Industrial/Limited Access Vehicular Gate Operator–Class III:** A vehicular gate operator (or system) intended for use in an industrial location or building such as a factory or loading dock area or other locations not accessible by or intended to service the general public

**Restricted Access Vehicular Gate Operator–Class IV:** A vehicular gate operator (or system) intended for use in an industrial location or building such as a factory or loading dock area or other locations not accessible by or intended to service the general public

**This vehicular gate operator must be installed with at least two independent entrapment protection means as specified in the table below.**

<b>GATE OPERATOR CATEGORY</b> Effective January, 12 2016		
<b>ENTRAPMENT PROTECTION TYPES</b>	<b>HORIZONTAL SLIDE VERTICAL LIFT - VERTICAL PIVOT</b>	<b>SWING VERTICAL BARRIER (ARM)</b>
	A, B1*, B2* or D	A, B1*, B2*, C or D
TYPE A	Inherent entrapment protection system	
TYPE B1	Non-contact sensors such as photoelectric sensors or equivalent	
TYPE B2	Contact sensors such as edge sensors or equivalent devices	
TYPE C	Inherent force limiting, inherent adjustable clutch or inherent pressure relief device	
TYPE D	Actuating device requiring constant pressure to maintain opening or closing motion of the gate	

The same type of device shall not be used for both entrapment protection means. Use of a single device to cover both the opening and closing directions is in accordance with the requirement; however, a single device is not required to cover both directions. Tice installer is required to install entrapment protection devices in each entrapment zone

**VERTICAL BARRIER NOTE:**

**Barrier gate operators (arm) that is not intended to move toward a rigid object closer than 16 inches (406mm) are not required to be provided with a means of entrapment protection**

**\* B1 and B2 means of entrapment protection MUST be MONITORED**

# GATE WARNINGS AND PRECAUTIONS

## GATE ARRANGEMENT

The first thing to check is that the gate is in good running order as follows:

- a) The gate is rigid and straight and runs smoothly throughout its travel.
- b) That the inferior sliding guide-rail is perfectly straight and horizontal to avoid a derailment of the gate (fig. 1); furthermore it must be free of irregularities and foreign bodies which could obstruct the normal run of the gate (fig. 2 - 3).
- c) That the upper guides are not fixed (fig. 4) but furnished with rollers
- d) That the distance between the end of the gate (in maximum opening position) and the eventual wall must be at least of 5 inches (fig. 7) which allow the sliding of the gate without difficulties (fig. 5 and 6).
- e) The lower support wheels have sealed bearings or grease points.
- f) The top guide must be manufactured and installed so that the gate is perfectly upright.
- g) Physical gate stops must be fitted to prevent the gate coming out of its guides and track.

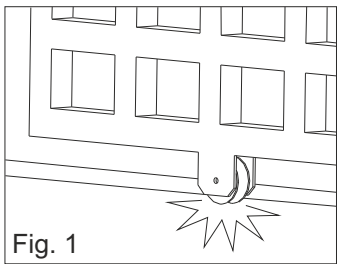

Fig. 1

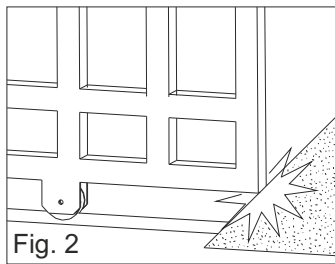

Fig. 2

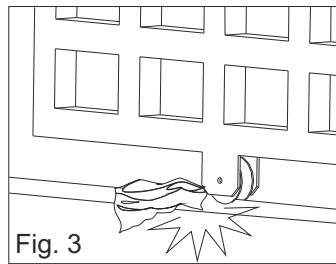

Fig. 3

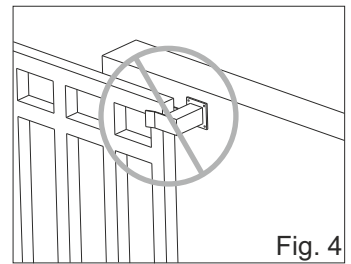

Fig. 4

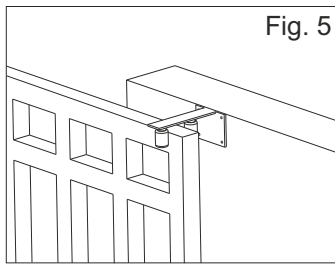

Fig. 5

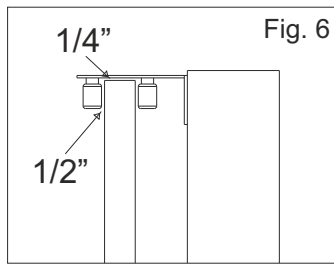

Fig. 6

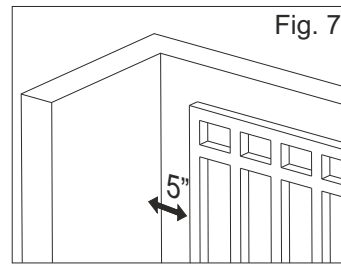

Fig. 7

## PRECAUTIONS

SEA operators have been created for the automation of gates used by vehicles only. Be aware to avoid the crossing of the gate path because it is very dangerous for pedestrians (fig.8).

Make sure that no person could activate the automation or act on it from the outside (fig. 9)

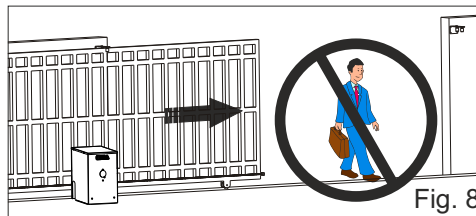

Fig. 8

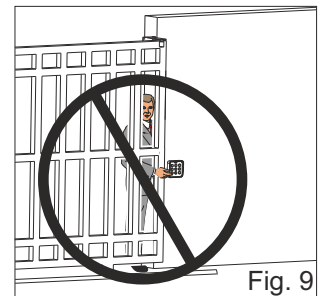

Fig. 9

## WARNING SIGNS

Install the warning signs, on each side of the gate and in a visible zone which informs the pedestrians about the danger they run when passing or resting in the environment of the gate

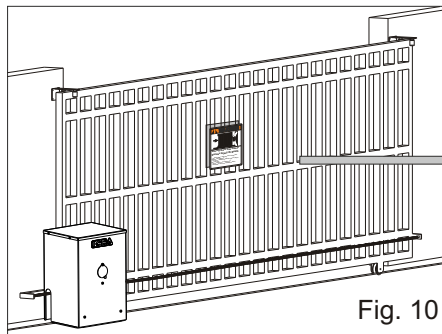

Fig. 10



## TYPE OF INSTALLATION

A front installation is the right and only possible installation, it is highly recommended to install two security gate stops on the two extremities of the rail to prevent the gate from derailment (fig. 11).

**Important:**  
For a higher security, SEA advises to install infrared photocells

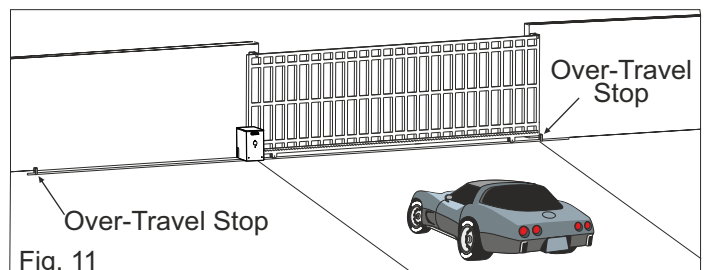

Fig. 11



## FEATURES AND SPECIFICATIONS

An electro-mechanical reduction operator

The ORION can be supplied with either:

A mechanic friction clutch or electronic sensing device as methods of limiting the motor torque.

The gates open & close stop limits are accurately archived by mechanically triggering the on-board micro-switch.

Manual release is quickly achieved by operating a key operated manual release system.

The microprocessor control unit has a choice of automatic or semi-automatic control logic and will provide all normal safety logic functions.

### GENERAL SWITCH

Into Orion you can find a general switch which allows to turn on or off the electric power supply of the automation. This switch must be set on "I" to make function the motor reducer and however after having correctly installed and adjusted all the components described in this instruction booklet.

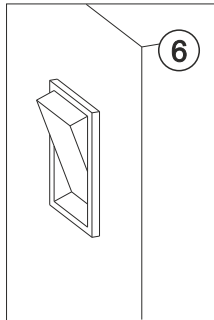

**Put the switch on "O" when you have to work on the motor reducer for repair or in case of power loss. For every intervene it is highly recommended to always turn off the electric power through the general switch for security.**

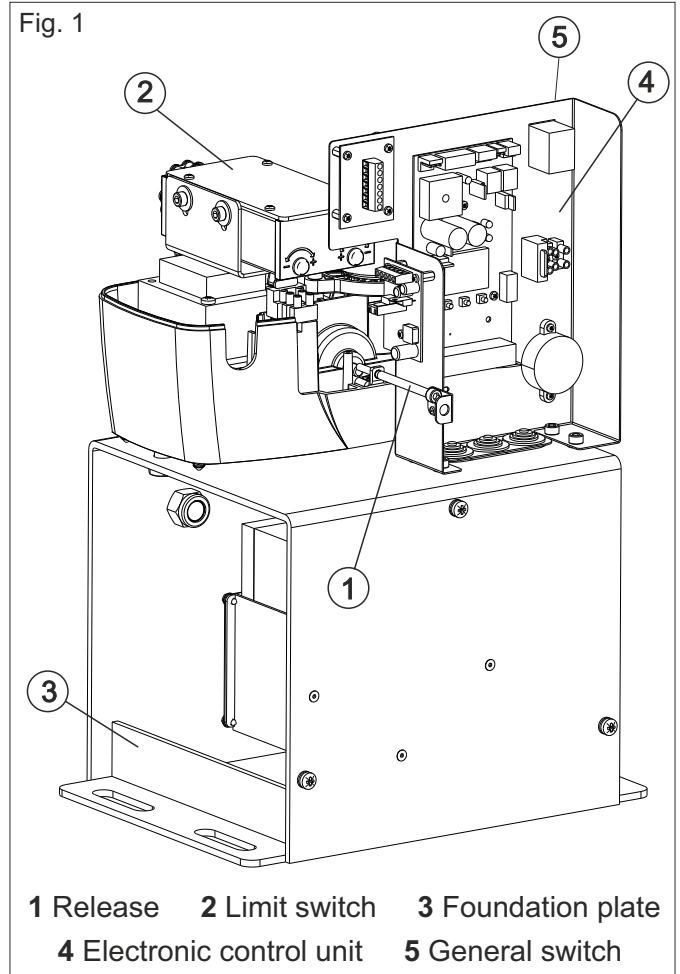

1 Release    2 Limit switch    3 Foundation plate  
4 Electronic control unit    5 General switch

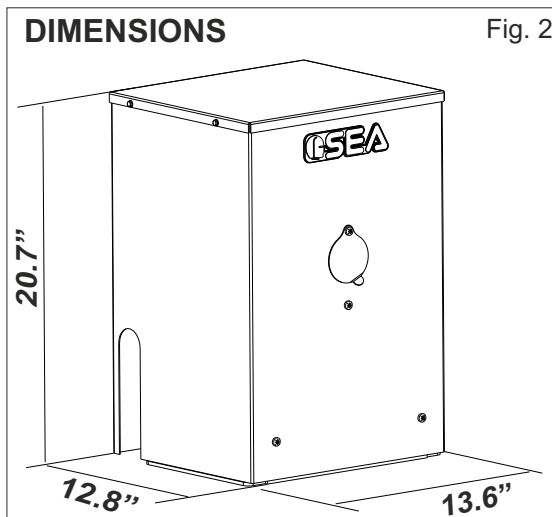

Fig. 2

TECHNICAL FEATURES	ORION 24V	ORION 24V FAST
Power supply	120 V (±5%) 50/60 Hz	120 V (±5%) 50/60 Hz
Power	130 W	160 W
Absorbed current	2,45 A	3,5 A
Thrust force	0/35 Nm	0/40 Nm
Leaf speed (pinion Z20)	Adjustable	Adjustable
Use rate	40 %	40 %
Max gate weight	662 lb	880 lb
Max gate opening	40 ft	40 ft
Type of limit switch	electromechanical	electromechanical
Operating temperatures	from -4°F to 131°F	from -4°F to 131°F
Operator weight	73 lb	73 lb
Protection class	IP 55	IP 55
Gate Operator Classification	I, II, III and IV	I, II, III and IV

**Note:** The frequency of use is valid only for the first hour at 68°F room temperature.



## MECHANICAL INSTALLATION

### TYPICAL INSTALLATION

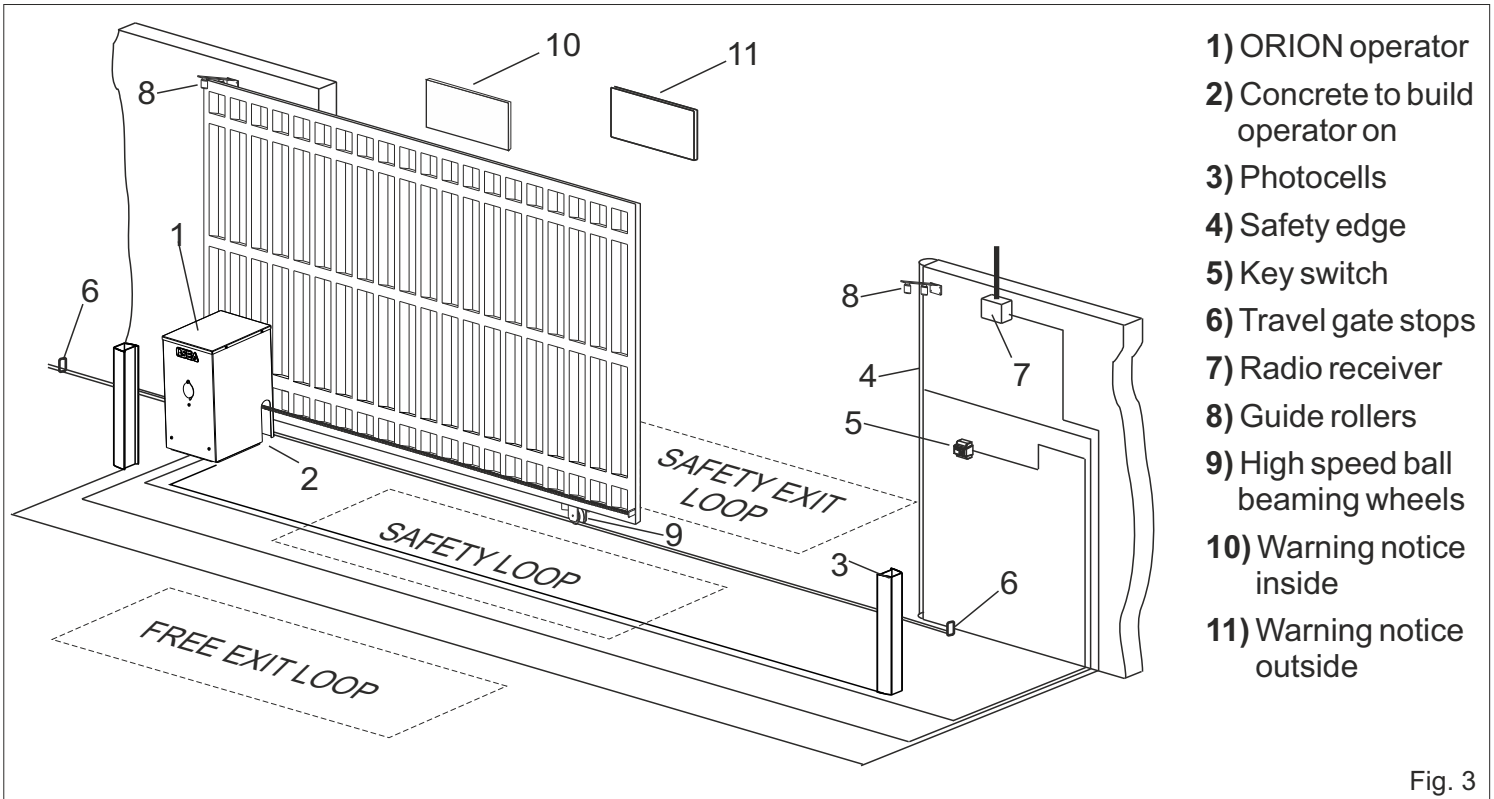

- 1) ORION operator
- 2) Concrete to build operator on
- 3) Photocells
- 4) Safety edge
- 5) Key switch
- 6) Travel gate stops
- 7) Radio receiver
- 8) Guide rollers
- 9) High speed ball beaming wheels
- 10) Warning notice inside
- 11) Warning notice outside

Fig. 3

### TYPE OF INSTALLATION

A front installation is the right and only possible installation, it is highly recommended to install two travel gate stops on the two extremities of the rail to prevent the gate from derailment (Fig. 4)

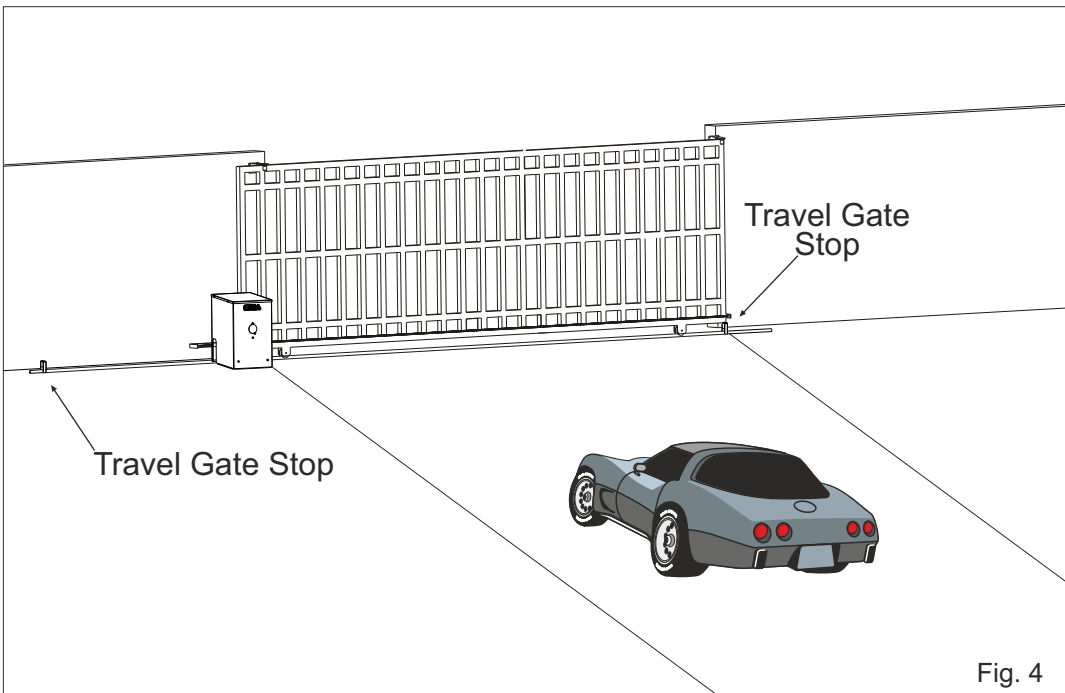

Install the operator always inside the property

Always install travel gate stops on both ends of the gate

**WARNING:**  
Only for vehicles access, pedestrians **MUST** have separate entrance.

Fig. 4



## CONCRETE PADS

1. Arrange a little square of concrete, see size in fig. 5, with a perfect levelling on which the motor reducer will be fixed with the special plugs (sizes see fig. 5)
2. Make sure that in the center of the concrete pad has been foreseen an exit for a sufficient number of conduit (for all accessories like loop detectors, maglock, photobeam and others)
3. Before piercing the concrete square for the fixation of the motor reducer, make sure that the distance between the centre of the oblong and the gate is of 3" (fig. 5)
4. All openings of a horizontal slide gate are guarded or screened from the bottom of the gate to a minimum of 4 feet (1,22 mt) above the ground to prevent a 2-1/2 inch (57,2 mm) diameter sphere from passing through the openings anywhere in the gate, and in that portion of the adjacent fence that the gate covers in the open position.
5. Follow the local building code to determine the required depth of the concrete pad.
6. SEA recommend the following pad measurements:

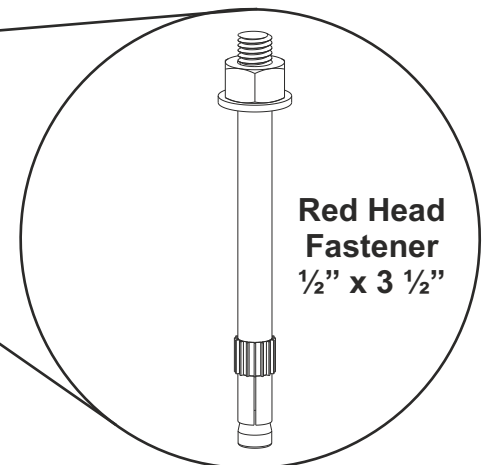
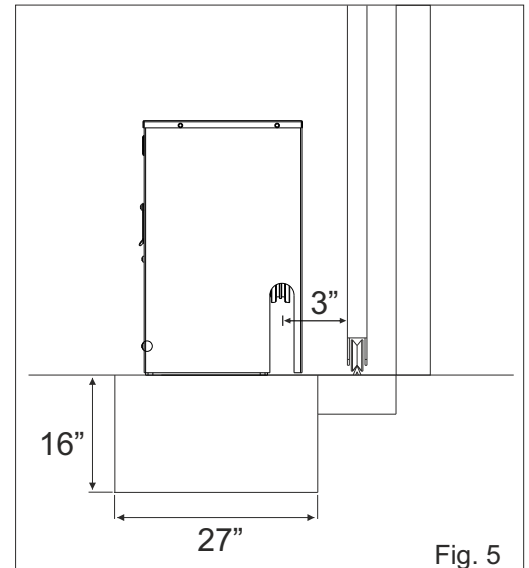
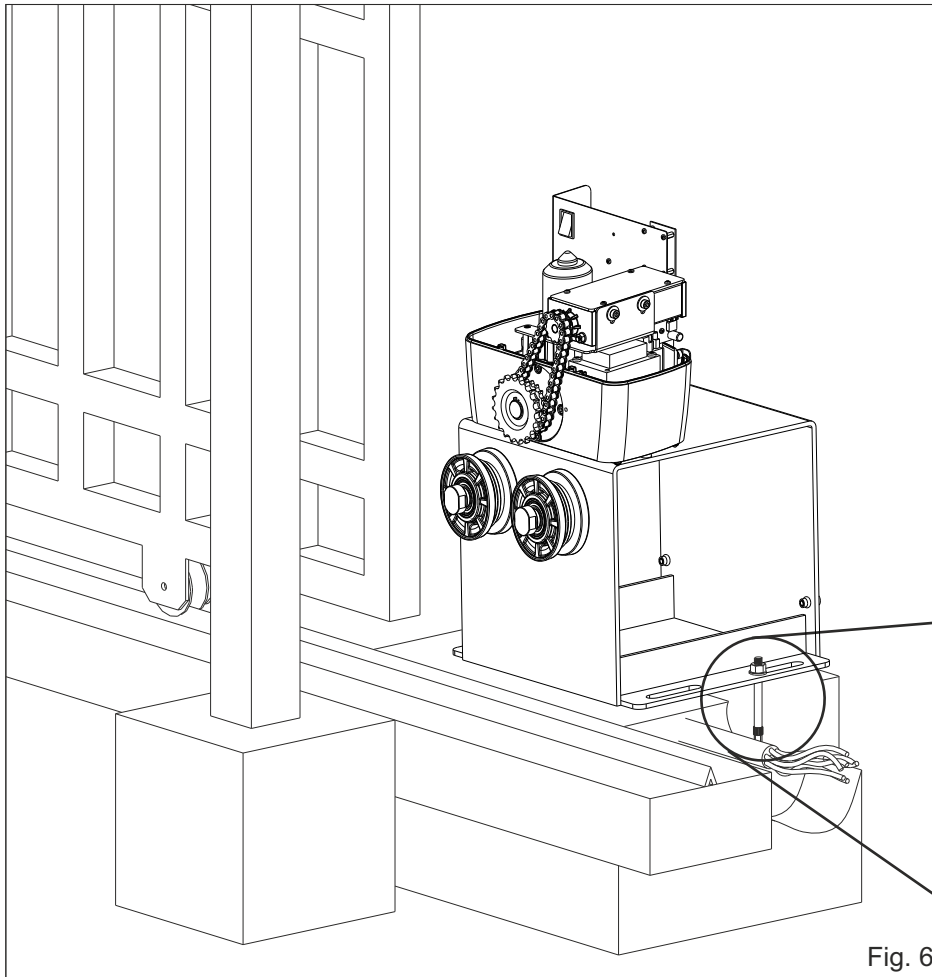

## GATE OPERATOR ATTACHMENT

1. Before starting the installation of the gate operator, make sure that the gate is in optimal conditions as for treeby turning wheels, no one impediments on the path of the gate, sufficient space between the gate and the adjaced walls.
2. The operator and the gate **MUST** be level and parallel.
3. Attach the operator on the prepared pad using Red Head 1/2" x 3 1/2" Anchors.



## CHAIN INSTALLATION

In the figures 7 and 8 it is possible to see the correct installation with opened and closed gate respectively; notice the obliged run of the chain inside the pinion group which must not be modified.

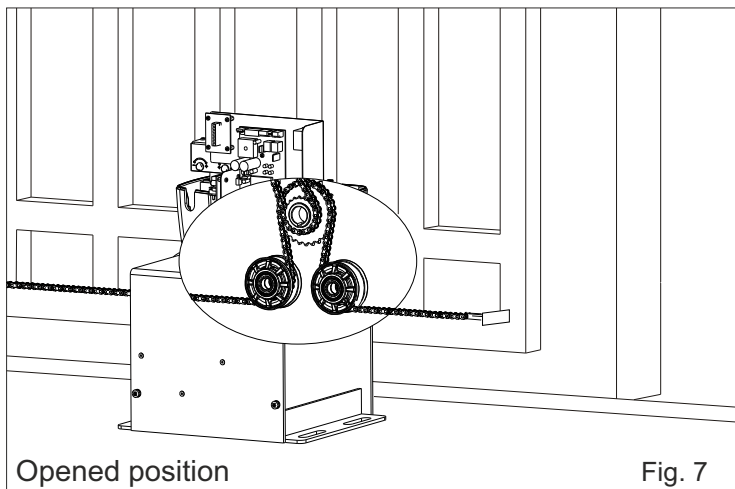

Opened position

Fig. 7

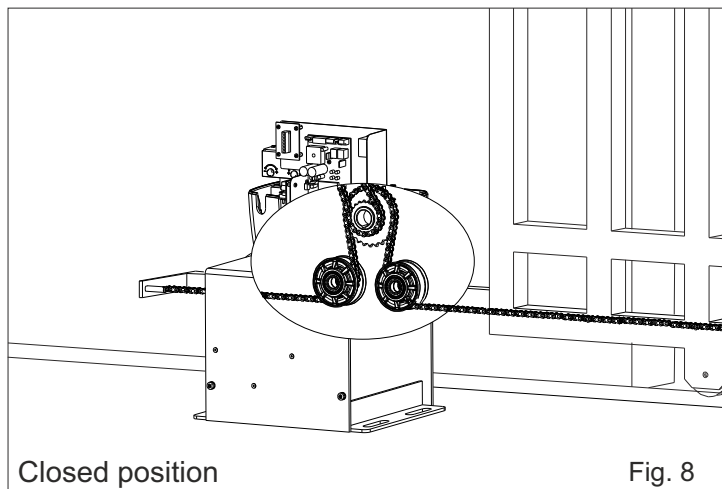

Closed position

Fig. 8

For a correct installation follow carefully the indications written below:

1. Fix the angle irons, with not supplied screws, to the two extremities of the gate and fix the chain with the provided tie rod (fig. 9).

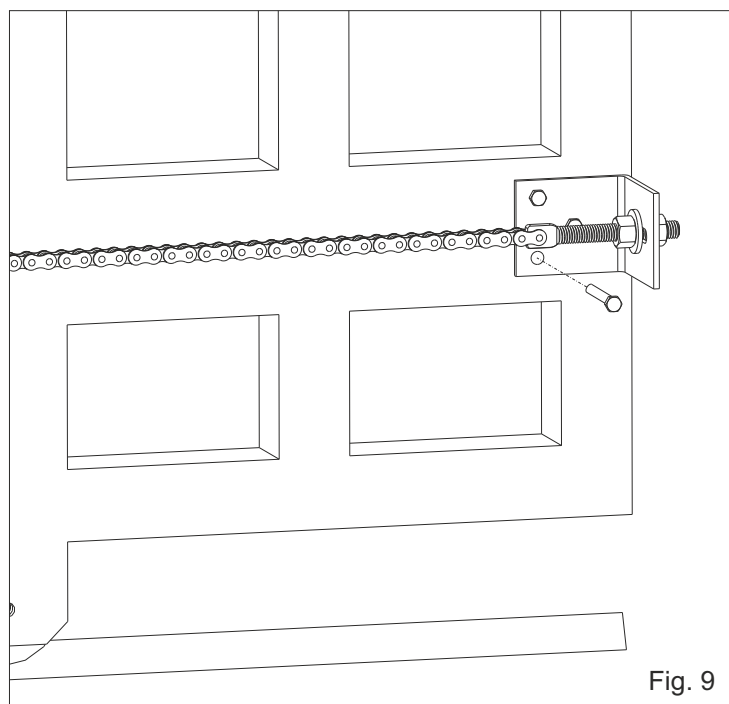

Fig. 9

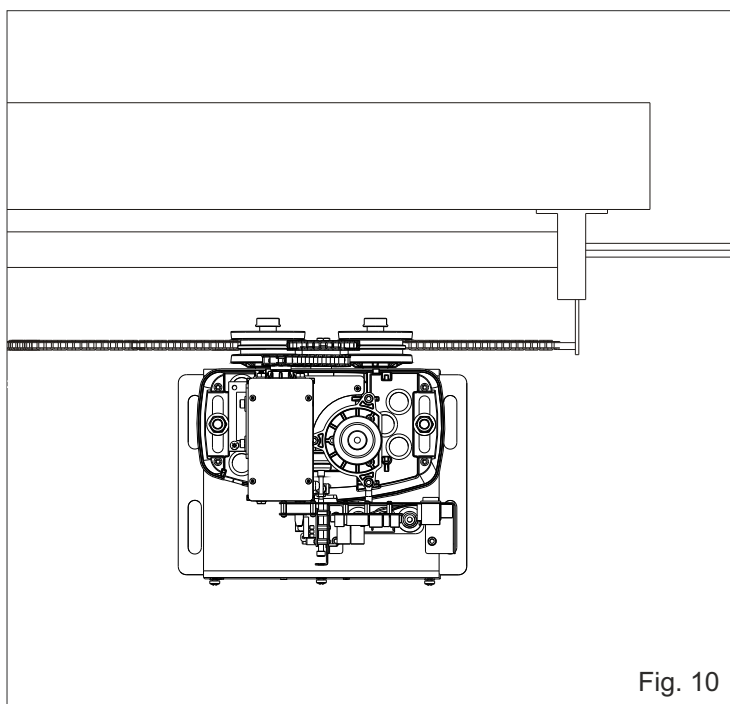

Fig. 10

2. Install the chain making it pass through the pinion group as in fig. 11. The chain must be always in line both vertically and horizontally, if not perfectly aligned (fig. 12 and 13) it may derail from the pinion group or the motor reducer risks a greater effort not allowing the right operating of the system.

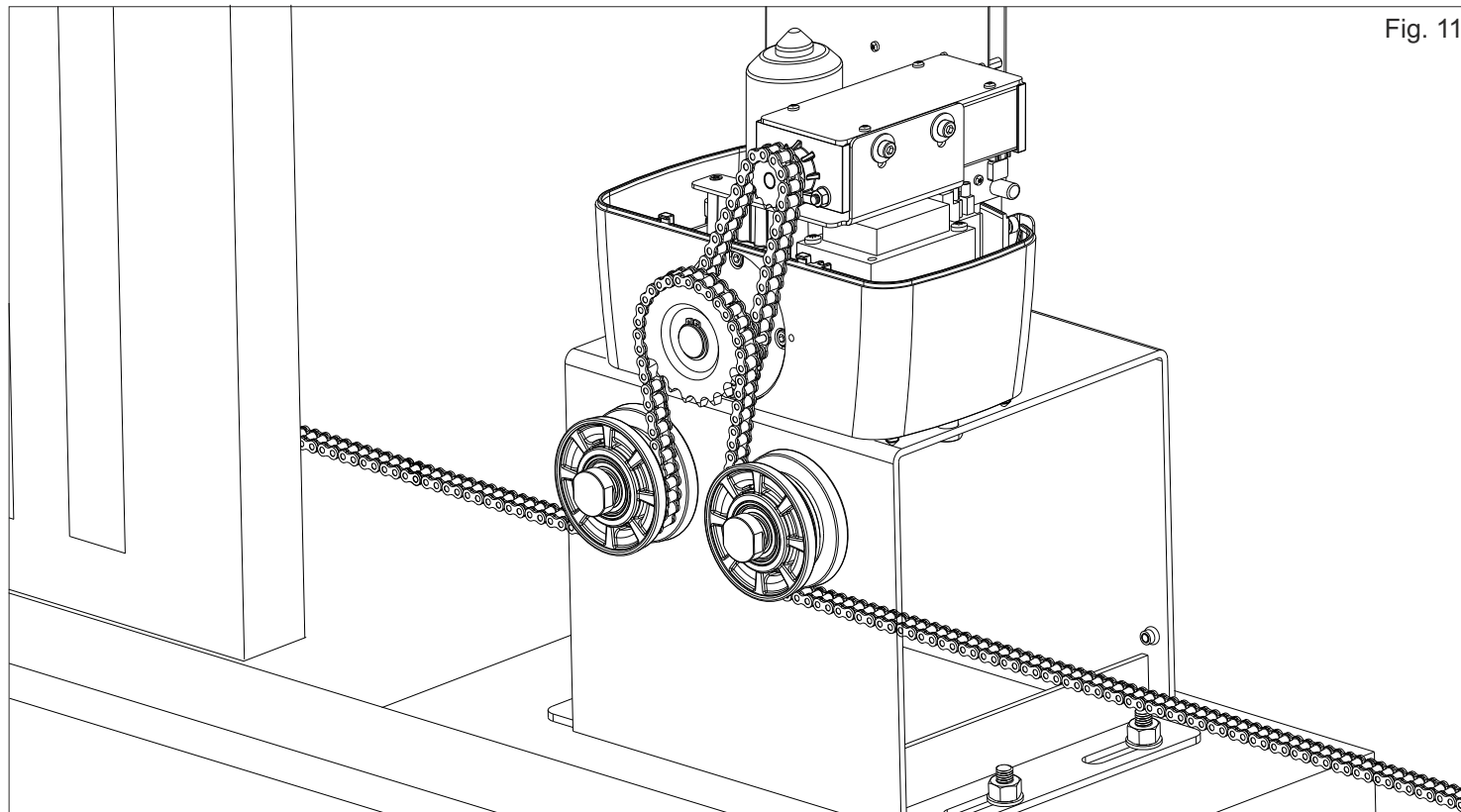

Fig. 11

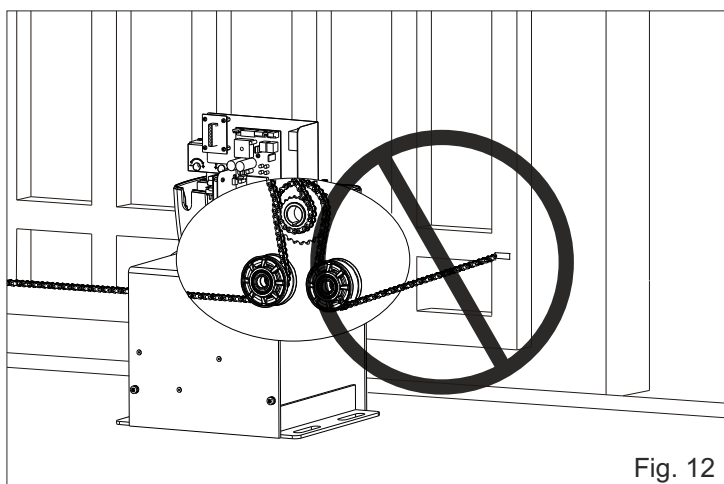

Fig. 12

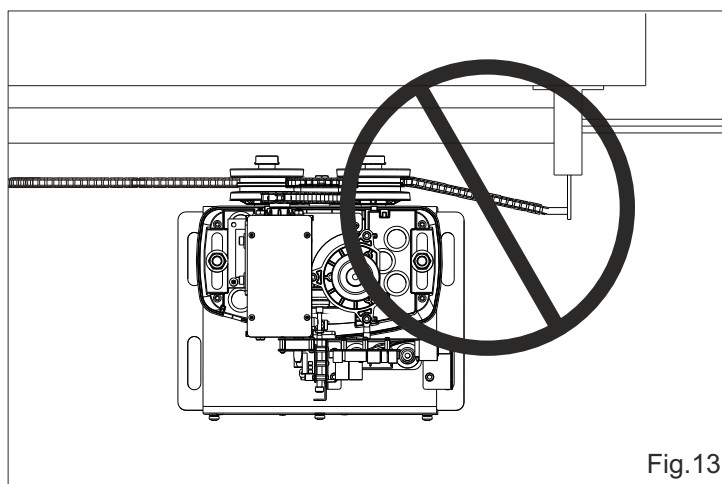

Fig. 13

3. Install a fillet chain tensioner to two extremity of the gate to regulate the tension of the chain.

**Note:** Execute this last operation with motor completely released using the provided special release key.

## MANUAL RELEASE SYSTEM



**WARNING:** Always switch off the main power (120V) before servicing the operator

*To release the gate:*

- Open the red door in front of the operator to left or right ( Fig. 14).
- Insert the hexagon "T" key (Fig. 15) and without forcing turn the key clockwise until it stops (Fig. 16).
- Manually open and close the gate.

*To reconnect:*

- Insert the hexagon "T" key and without forcing , turn anticlockwise until it stops (Fig. 16).
- Slowly manually push the gate until it reconnects the drive.
- **Do not attempt to use the operator electrically before reconnecting the drive.**

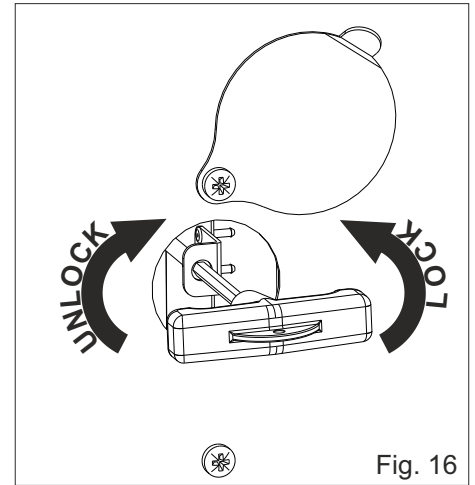
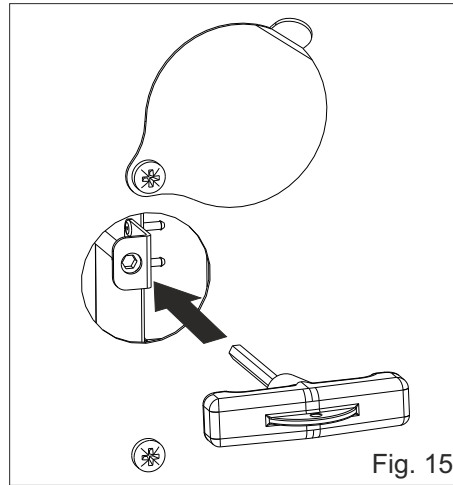
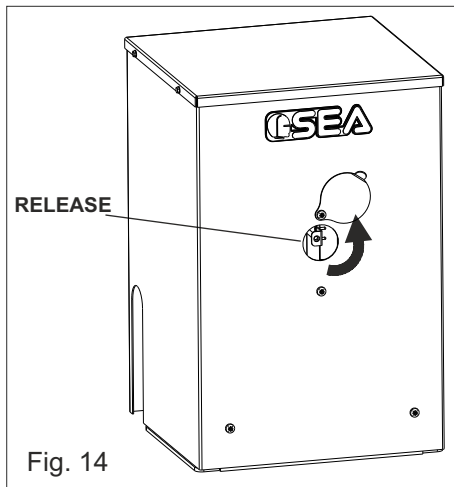

**SEA recommend to the end user to release the operator only in case of power failure.  
Always contact the professional install for malfunctioning of the operators.**

## LIMIT-SWITCH SETUP

1. Remove the operator cover
2. The main power (120V) **MUST** be disconnected
3. Before acting on the limit switch, make sure that during the assembling of the motor with chain attached to the gate, the limit switch cursor are in the central position of its run (fig. 17) and the gate is in the middle of its opening.

**To set and/or adjust the limit switch act only on the external screw. Do not open the case of the limit switch.**

4. To install and adjust the limit switches in **opening**, see the following instructions:

- release the motor
- open the gate manually
- act on the adjusting screw so that the microswitch can activate the contact with the cursor (Fig. 18)

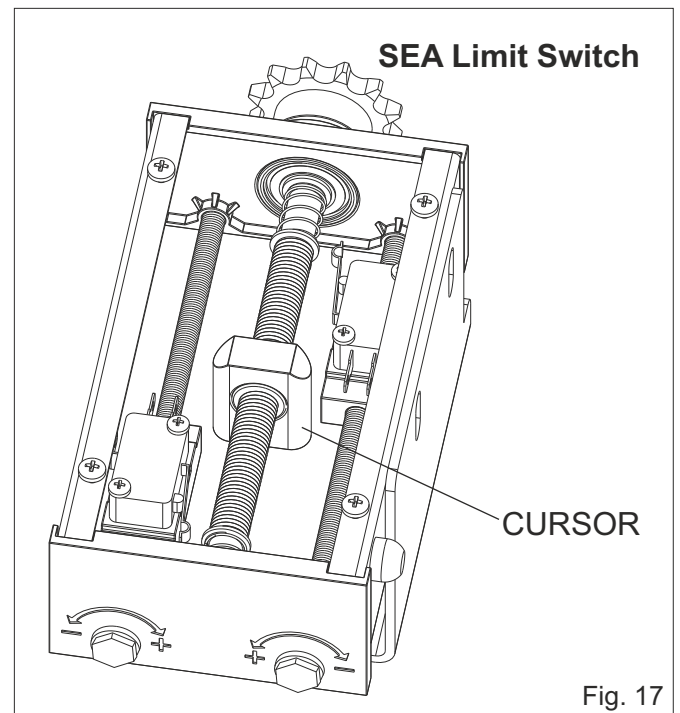



5. To install and adjust the limit switches in **closing**, see the following instructions:

- release the motor
- close the gate manually
- act on the adjusting screw so that the microswitch can activate the contact with the cursor (Fig. 19)

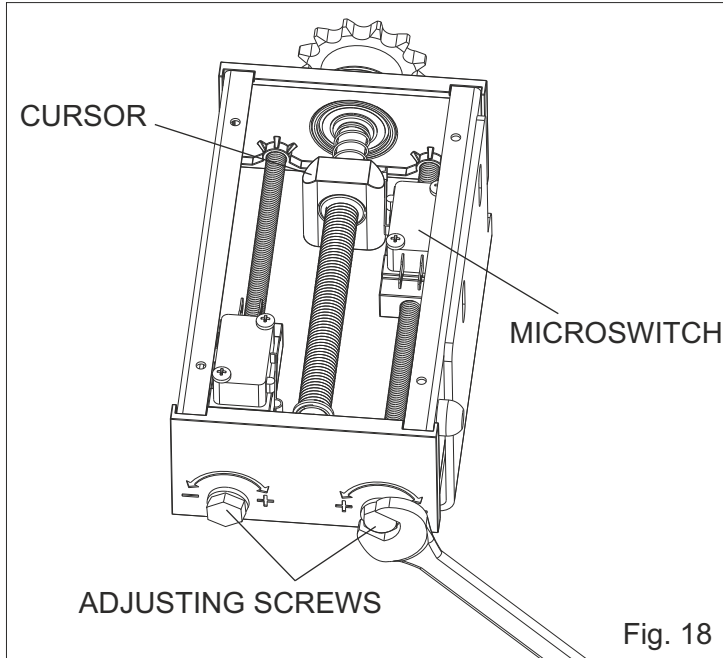

Fig. 18

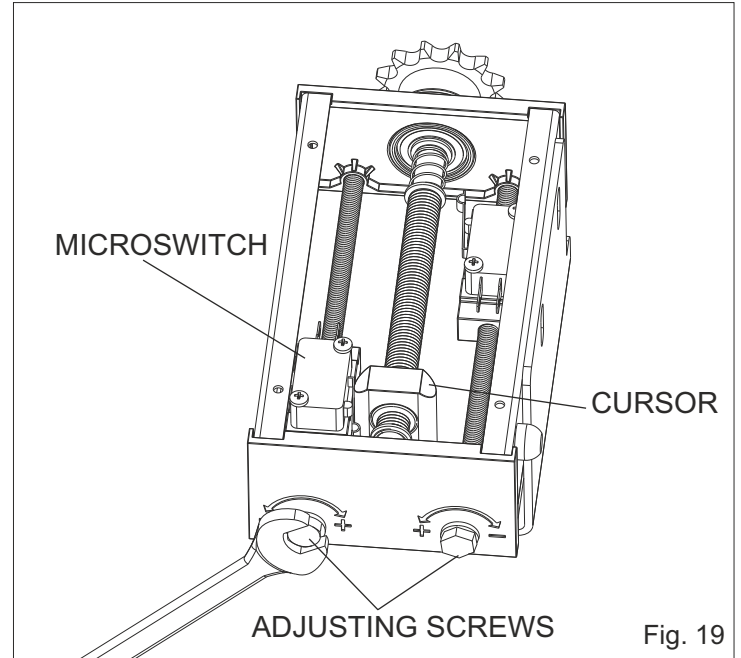

Fig. 19

To have a more accurate adjustment, act on the adjusting screws in the testing phase with AC power, after having executed the previous operations.

**Notice:** to adjust the movement directions, make reference to the instructions of the electronic control unit. For limit switch connections see instructions on the electronic installation manual

## 120 V~ SINGLE PHASE POWER CONNECTIONS

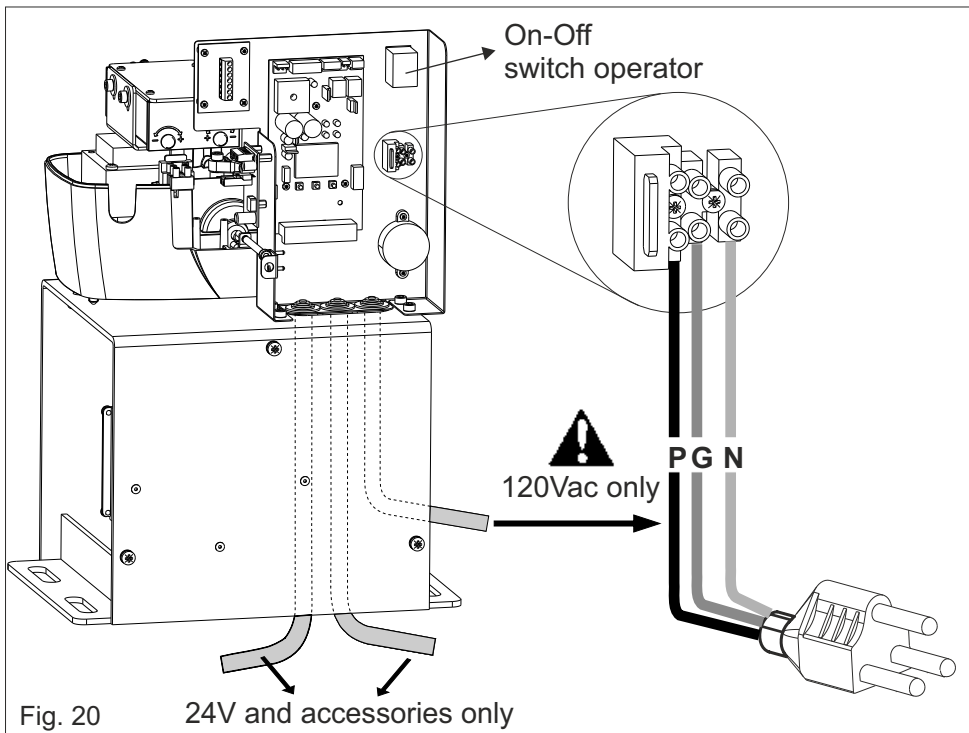

Fig. 20

120 V~ Power Wire	½ HP and dual motor	1 HP
16 Gauge	Up to 150 FT	Up to 75 FT
14 Gauge	250 FT	125 FT
12 Gauge	400 FT	200 FT
10 Gauge	650 FT	325 FT
8 Gauge	1000 FT	500 FT
4 Gauge	2200 FT	1100 FT

**P** = Single Phase 120 V~  
**G** = Ground  
**N** = Neutral



### WARNING:

Keep the power cables (motors, power supply) **SEPARATE** from the command cables (push buttons, photocells and so on). In order to avoid any interference it's preferable to foresee and use two separate sheaths

### RISK EXAMINATION

The points pointed by arrows in fig. 21 are potentially dangerous. The installer must take a thorough risk examination to prevent crushing, conveying, cutting, grappling, trapping so as to guarantee a safe installation for people, things and animals. (Re. Laws in force in the country where installation has been made.). As for misunderstandings that may arise refer to your area distributor or call our help desk. These instructions are part of the device and must be kept in a well known place. The installer shall follow the provided instructions thoroughly. SEA USA Inc. products must only be used to automatise doors, gates and l wings. Any initiative taken without SEA USA Inc. explicit authorization will preserve the manufacturer from whatsoever responsibility. The installer shall provide warning notices on not assessable further risks. SEA USA Inc. in its relentless aim to improve the products, is allowed to make whatsoever adjustment without giving notice. This doesn't oblige SEA USA Inc. to up-grade the past production. SEA USA Inc. can not be deemed responsible for any damage or accident caused by product breaking, being damages or accidents due to a failure to comply with the instructions herein. The guarantee will be void and the manufacturer responsibility will be nullified if SEA USA Inc. original spare parts are not being used. The electrical installation shall be carried out by a professional technician who will release documentation as requested by the laws in force. Packaging materials such as plastic bags, foam polystyrene, nails etc must be kept out of children's reach as dangers may arise.

### NOTICE

SEA USA Inc. can not be deemed responsible for any damage or accident caused by product breaking, being damages or accidents due to a failure to comply with the instructions herein. The guarantee will be void and the manufacturer responsibility will be nullified if SEA USA Inc. original spare parts are not being used. The electrical installation shall

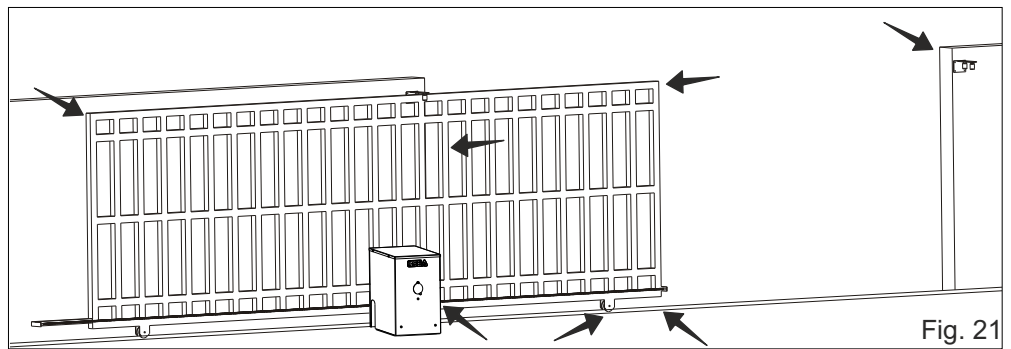

be carried out by a professional technician who will release documentation as requested by the laws in force. Packaging materials such as plastic bags, foam polystyrene, nails etc must be kept out of children's reach as dangers may arise.

## PERIODICAL MAINTENANCE

1) Check the release function	Annual
2) Check the clutch function on the gate	Annual
3) Check the fixing screws	Annual
4) Check the integrity of the connection cables	Annual
5) Check the function and the limit switch condition in opening and closing	Annual
6) Check the chain works perfectly and is well greased	Annual
7) Inspect the track for any signs of cracking or separation	Annual
8) Clean the gate track wheels and lubricate them with recommended lubricant	Annual
9) Verify the battery back up systems by disconnecting the power source (120V). REMEMBER to turn on the power source after check.	Annual
10) Check for all corroded parts and replace them	Annual
11) Check the tight of the hardware of the gate	Annual
12) Check the operating of all accessories. Especially the functioning of all safety devices and reversing sensors	Annual



**All the above described operations MUST be made exclusively by an authorized installer**



## **SALES CONDITIONS and WARRANTY**

**GENERAL WARNING:** Installation must be realized using parts and accessories approved by SEA. SEA is not responsible for incorrect installations and/or non-compliance with safety standards according to the law in-force. SEA is in no way liable for any damages and/or malfunctioning due to using parts and accessories non-compliant with the UL325 safety standards.

**ORDERS:** Orders are processed upon approval by SEA. Buyers must confirm orders by sending a written Purchase Orders to SEA. Purchase Orders are intended as confirmation of orders and binding for the buyer, which accepts SEA sales condition.

**QUOTATION:** Quotation and special offers with a non-specified duration expires automatically after 30 days.

**PRICES:** Prices are based on the Price List in force. Discounts and quotation from Sales Rep. and other selling branches must be approved by SEA. Prices are F.O.B SEA Warehouse in Miami and do not include shipments costs. SEA reserves the right to modify the price list at any time and provide notice to its sales network.

**PAYMENT:** Method of payments and terms are notified by SEA and displayed on the commercial invoice.

**DELIVERY:** The delivery time on the invoice is not binding and represents an estimated delivery. Shipments costs will be charged to the buyer and SEA is not responsible for delays and/or damages occurred to the products during shipment.

**COMPLAINS:** Complains and/or claims must be notified to SEA within 7 business days after receiving the products. Claims and complains must be supported by original documents. Customer must contact the factory for instructions and authorization. Merchandise returned for credit must be current, uninstalled and unused and returned in its original packaging. Freight must be pre-paid on all authorized returns.

**REPAIRS:** Repairs and parts are subject to the availability in stock. Shipment of products for repairs must be pre-paid by the customer. Products shipped without authorization, sender's details and description of the problems will be refused. Customers must contact SEA for instructions.

**WARRANTY:** for the original buyer only:

Hydraulic and oil-bath motors: 36 months warranty from the date of invoice on manufacturing, assembling and workmanship defects.

Electro-mechanic motors and electronic control systems: 24 months warranty from the date of invoice on manufacturing, assembling and workmanship defects.

Lepus and Full Tank Standard model: 60 months warranty from the date of invoice on manufacturing, assembling and workmanship defects.

No warranty will be recognized for damages due to incorrect installation and/or improper use for which the product was intended. SEA warranty obligations shall be limited to repair or replace the defective product/parts at SEA option, upon examination of the products by SEA technical Staff. All replaced parts must remain property of SEA. The warranty status of the product remains an unquestionable assessment of SEA. Buyer must ship pre-paid defective products. Products under warranty will be returned pre-paid by SEA. Recognized defects, whatever their nature, will not produce any responsibility and/or damage claims to SEA USA Inc and SEA s.r.l. Warranty shall not cover any required labor activities. Warranty will in no case be recognized if alterations and any other changes will be found on products. Warranty will not cover damages caused by carriers, expendable materials and faults due to improper use with the products specifications. No indemnities are recognized during repairing and/or replacing of the products under warranty. SEA USA Inc. and SEA s.r.l. decline any responsibility for damages to person and objects deriving from non-compliance with safety standards, installation instructions or use of the products sold. It is intended that warranty will be recognized only on products bought through the SEA authorized network. Products must be installed by professionals. No warranty will be recognized if products are installed directly by the final user. Warranty does not apply in case of unexpected events such as fire, flood, electrical power surge, lightning, vandalism and others.

**SEA USA Inc. is not responsible for errors in technical information printed in catalogs and installation manuals.**



**SEA USA Inc.**  
**10850 N.W. 21st unit 160 DORAL MIAMI**  
**Florida (FL) 33172 USA**  
**Phone: ++1-305.594.1151 Fax: ++1-305.594.7325**  
**Toll Free: 800.689.4716**  
**web site: [www.sea-usa.com](http://www.sea-usa.com)**  
**e-mail: [sales@sea-usa.com](mailto:sales@sea-usa.com)**