

USER 2 DG 24V R1B - ALL IN

**CENTRALE ELETTRICA 24V $\overline{\text{=}}$ PER OPERATORI A BATENTE
24V $\overline{\text{=}}$ ELECTRONIC CONTROL UNIT FOR SWING OPERATORS
ARMOIRE DE COMMANDE 24V $\overline{\text{=}}$ POUR OPERATEURS A BATTANT
CENTRAL ELECTRÓNICA 24V $\overline{\text{=}}$ PARA OPERADORES BATIENDES**

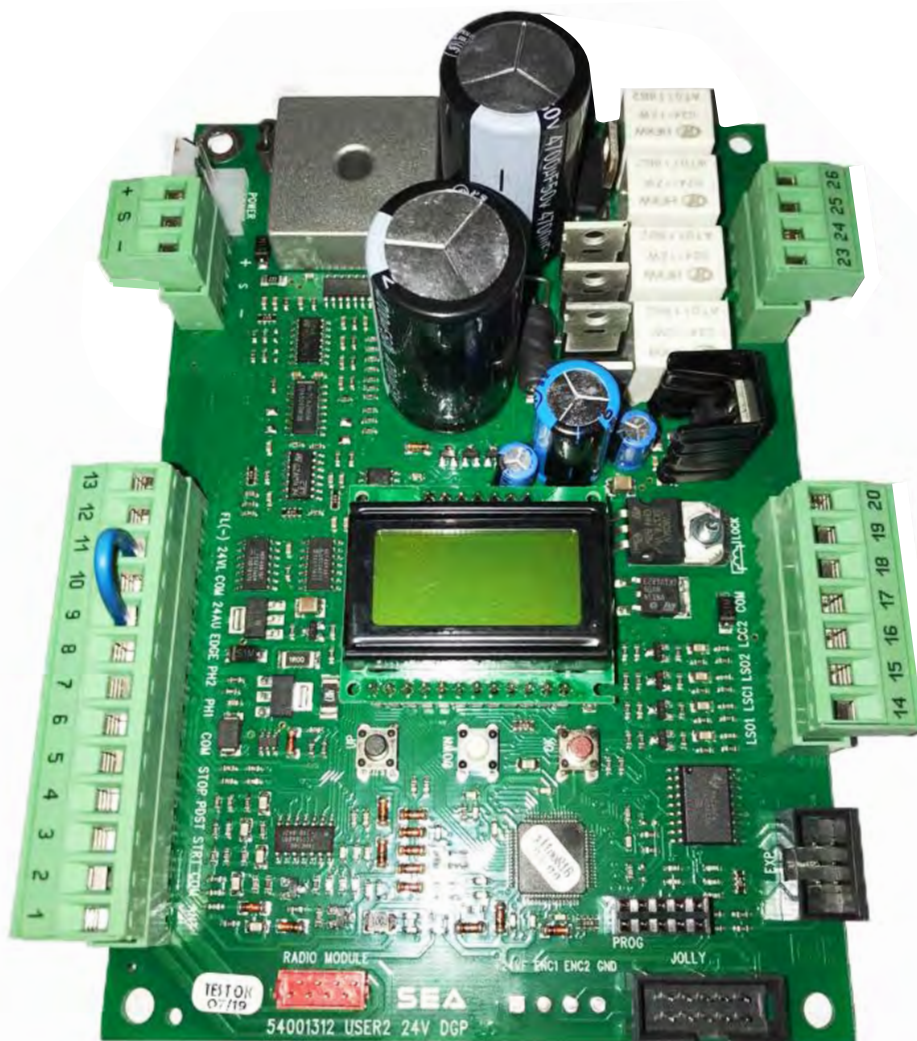

SEA S.p.A.

Zona Industriale Sant' Atto - 64020 - Teramo - ITALY
Telephone: + 39 0861 588341 - Fax: + 39 0861 588344

www.seateam.com
seacom@seateam.com

INDICE - INDEX - ÍNDICE

CAPITOLO		PAGINA	CHAPTER		PAGE	CHAPITRE		PAGE	CAPÍTULO		PÁGINA
1	Componenti	3	Components	34	Composants	65	Componentes	96			
2	Connessioni	4	Connections	35	Connexions	66	Conexiones	97			
3	Jumpers	4	Jumpers	35	Jumpers	66	Jumpers	97			
4	Collegamenti su CN1	5	Connections on CN1	36	Connexions sur CN1	67	Conexiones en CN1	98			
4.1	Start	5	Start	36	Start	67	Start	98			
4.2	Start Pedonale	5	Partial opening Start	36	Start Piéton	67	Start Peatonal	98			
4.3	Stop	5	Stop	36	Stop	67	Stop	98			
4.4	Fotocellule 1 e 2	5	Photocells 1 and 2	36	Photocellules 1 et 2	67	Fotocélulas 1 y 2	98			
4.5	24V AUX	5	24V AUX	36	24V AUX	67	24V AUX	98			
4.6	Timer	5	Timer	36	Timer	67	Timer	98			
4.7	Lampeggiante	6	Flashing lamp	37	Lampe clignotante	68	Lámpara	99			
4.8	Costa di sicurezza	6	Safety edge	37	Tranche de sécurité	68	Banda de seguridad	99			
4.9	Fotocellule 10K	6	10K Photocells	37	Photocellules 10K	68	Fotocélulas 10K	99			
4.10	Buzzer	6	Buzzer	37	Buzzer	68	Buzzer	99			
4.11	Spira di sicurezza	7	Safety loop	38	Spire de sécurité	69	Espira de seguridad	100			
4.12	Serratura magnetica	7	Magnetic lock	38	Serrure magnétique	69	Cerradura magnética	100			
4.13	Ricevente esterna	8	External receiver	39	Récepteur externe	70	Receptor externo	101			
4.14	Latch opening/closing	8	Latch opening/closing	39	Latch opening/closing	70	Latch opening/closing	101			
5	Collegamenti su CN2	9	Connections on CN2	40	Connexions sur CN2	71	Conexiones en CN2	102			
5.1	Finecorsa	9	Limit switch	40	Fin de course	71	Final de carrera	102			
5.2	Elettroserratura	9	Electric lock	40	Serrure électrique	71	Cerradura eléctrica	102			
6	Collegamenti su CN3	10	Connections on CN3	41	Connexions sur CN3	72	Conexiones en CN3	103			
6.1	Collegamento motori	10	Motors connection	41	Connexion moteurs	72	Conexión motores	103			
7	Collegamenti su CN5	11	Connections on CN5	42	Connexions sur CN5	73	Conexiones en CN5	104			
7.1	Collegamento switching	11	Switching connection	42	Connexion switching	73	Conexión switching	104			
7.2	Batterie (E-SUN / E-SUN Q)	11	Batteries (E-SUN / E-SUN Q)	42	Batteries (E-SUN / E-SUN Q)	73	Baterias (E-SUN/E-SUN Q)	104			
8	Collegamenti esterni	12	External connections	43	Connexions externes	74	Conexiones externas	105			
8.1	Scheda gestione SEM 2	12	SEM 2 management unit	43	Unité de gestion SEM 2	74	Unidad de gestión SEM 2	105			
8.2	Scheda gestione LSE	12	LSE management unit	43	Unité de gestion LSE	74	Unidad de gestión LSE	105			
8.3	Circuito Surge Protector	13	Surge Protector circuit	44	Circuit Surge Protector	75	Circuito Surge Protector	106			
9	Altre funzionalità	13	Other functions	44	Autres fonctions	75	Otras funciones	106			
9.1	Gestione amperometrica	13	Amperometric management	44	Gestion ampérométrique	75	Gestión amperométrica	106			
10	Preliminari	14	Preliminary	45	Préliminaires	76	Preliminares	107			
11	Avvio rapido	15	Quick Start	46	Démarrage rapide	77	Arranque rápido	108			
12	Tempi di lavoro	16	Working times	47	Temps de travail	78	Tiempos de trabajo	109			
13	Logiche	17	Logics	48	Logiques	79	Lógicas	110			
14	Password	18	Password	49	Password	80	Password	111			
15	Gestione ingressi	19	Input management	50	Gestion des entrées	81	Gestión entradas	112			
16	Telecomandi	21	Remote controls	52	Télécommandes	83	Transmisores	114			
--	Tabella dei menù	23	Menu table	54	Tableau des menu	85	Tabla de menu	116			
--	Indicazioni Allarmi	30	Alarms indications	61	Indications alarmes	92	Indicaciones alarmas	123			

1 - COMPONENTS

TECHNICAL FEATURES

Power supply: 24V~
 Absorption in stand by: 30 mA
 Environment temperature: -20°C / +50°C
 External box: 305 x 225 x 125 mm - IP55

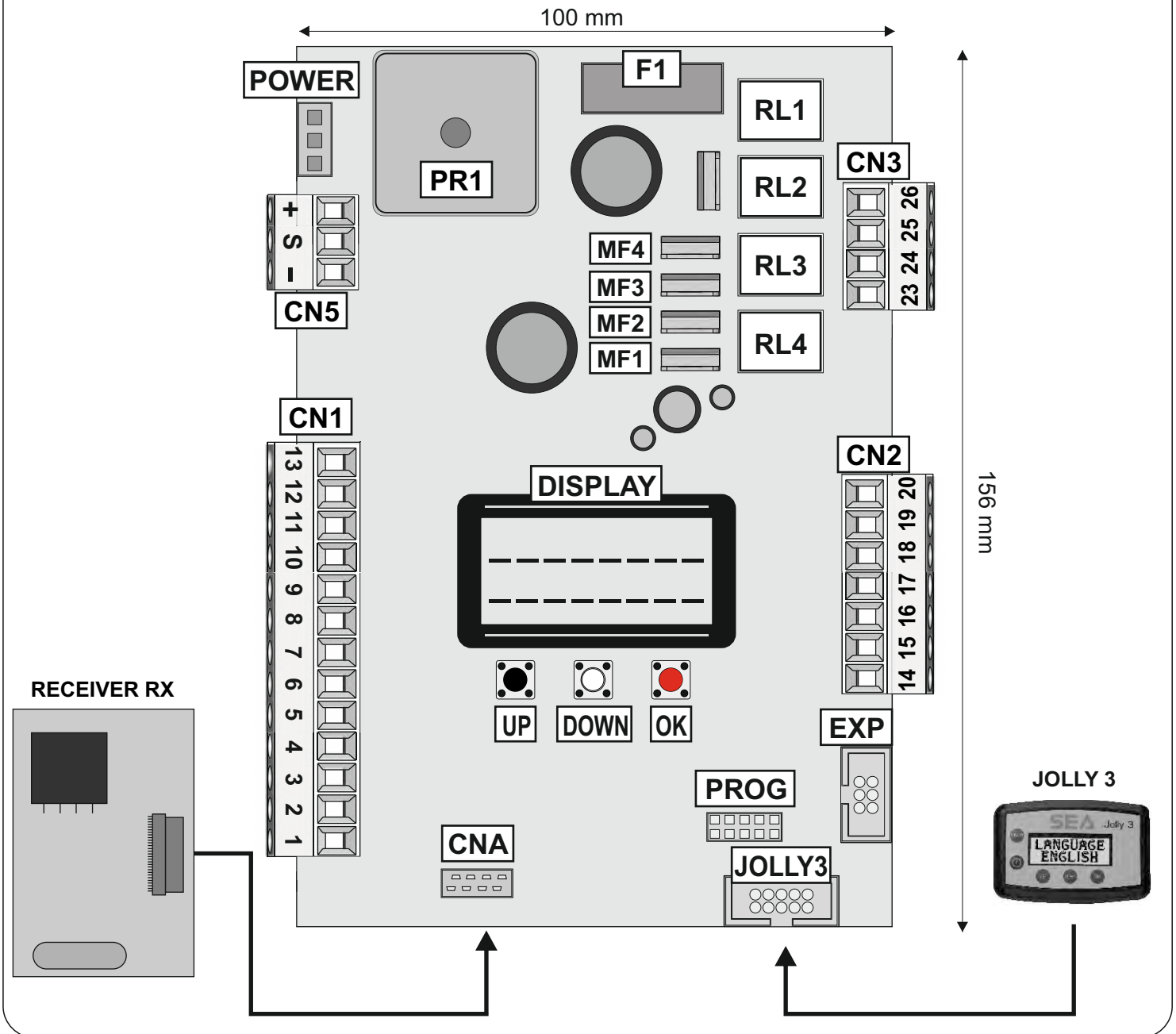

CN1 = Input/Output connector
CN2 = Limit switch or electric-lock connector
CN3 = Motors connector
CN5 = Battery charger connector
CNA = RX receiver module connector
EXP = External module connector
JOLLY 3 = JOLLY 3 or SEACLOUD connector
F1 = Fuse 10AT

MF1 - MF2 = Mosfet motor 2
MF3 - MF4 = Mosfet motor 1
POWER = 24V~ power supply connector
PROG = Programming connector
PR1 = Rectifier jumper
RL1 - RL2 = Relay motor 2
RL3 - RL4 = Relay motor 1

2 - CONNECTIONS

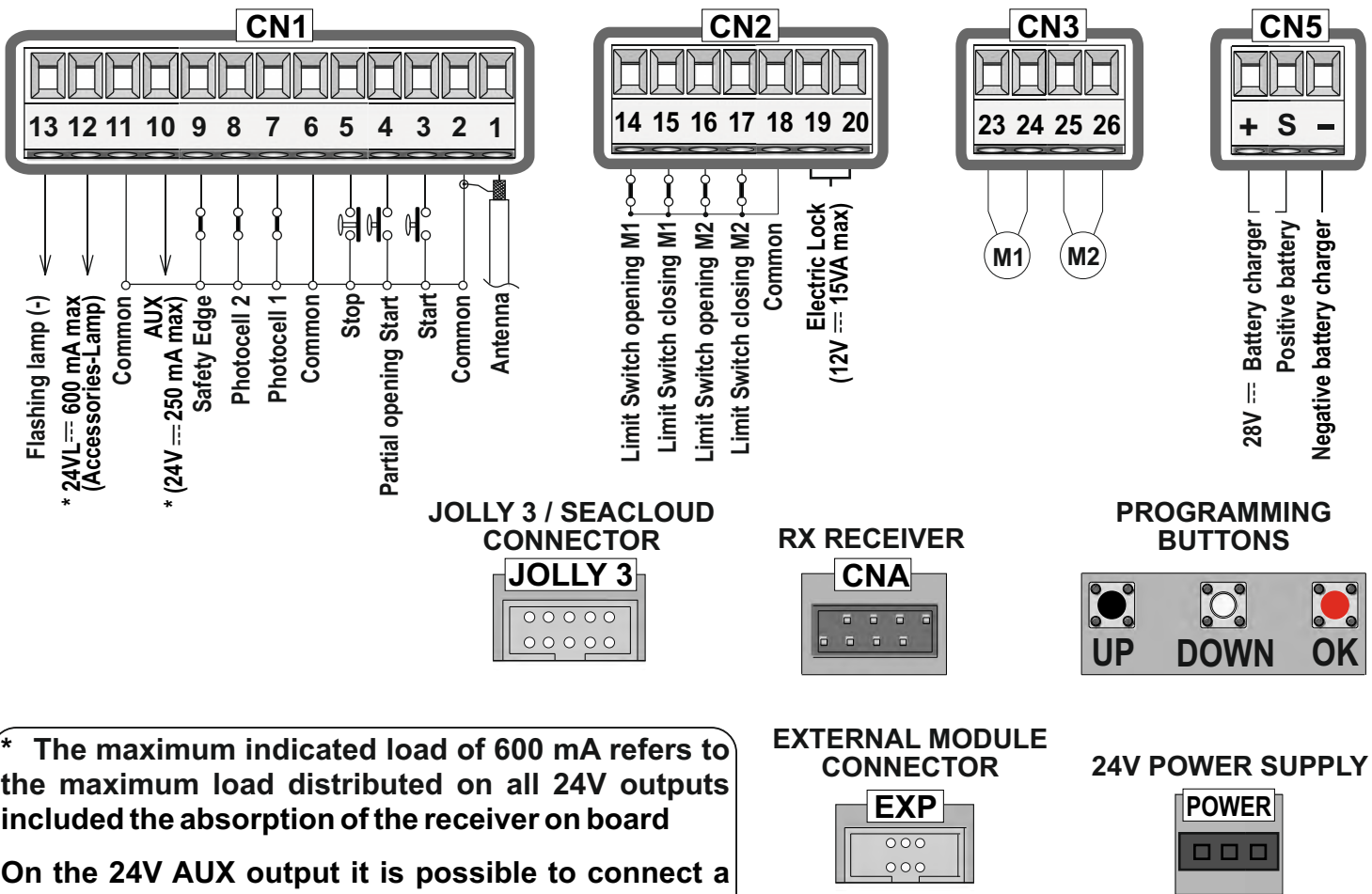

3 - JUMPERS

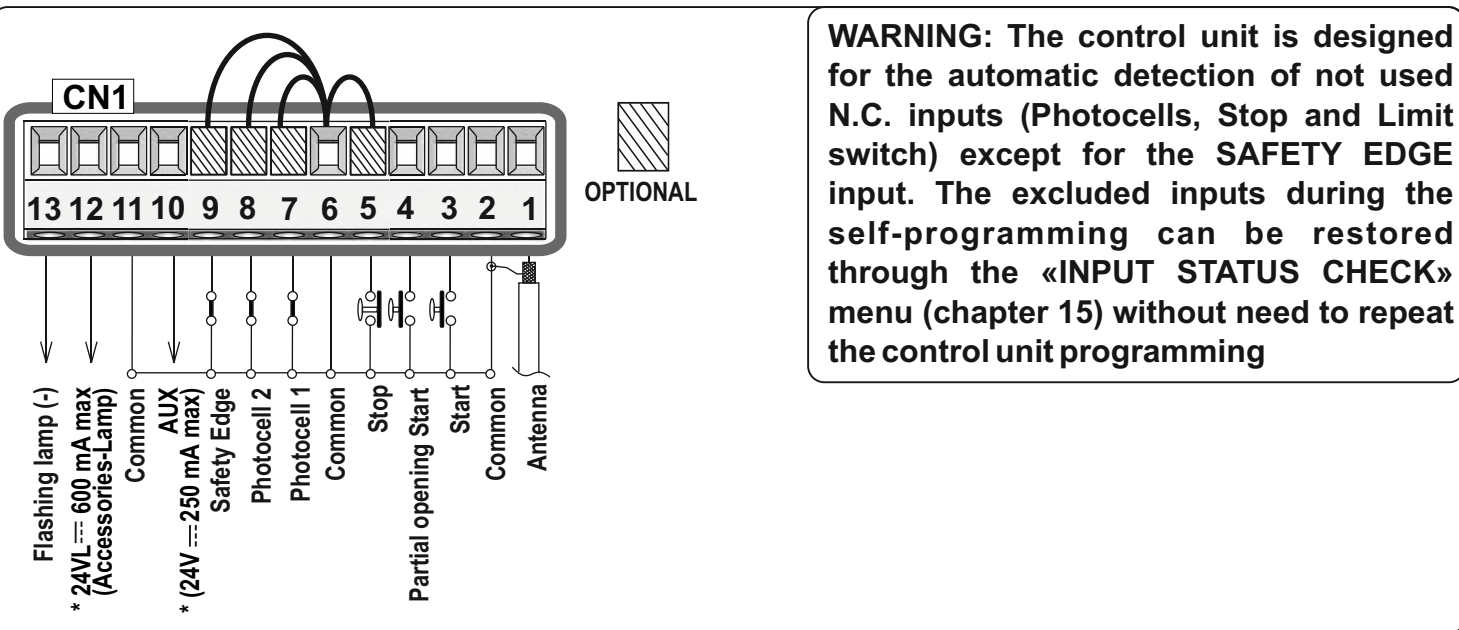

NOTE:

The herein reported functions are available starting from Software Revision 03.00 of this control unit and it is compatible with JOLLY 3 programmer

4 - CONNECTIONS ON CN1

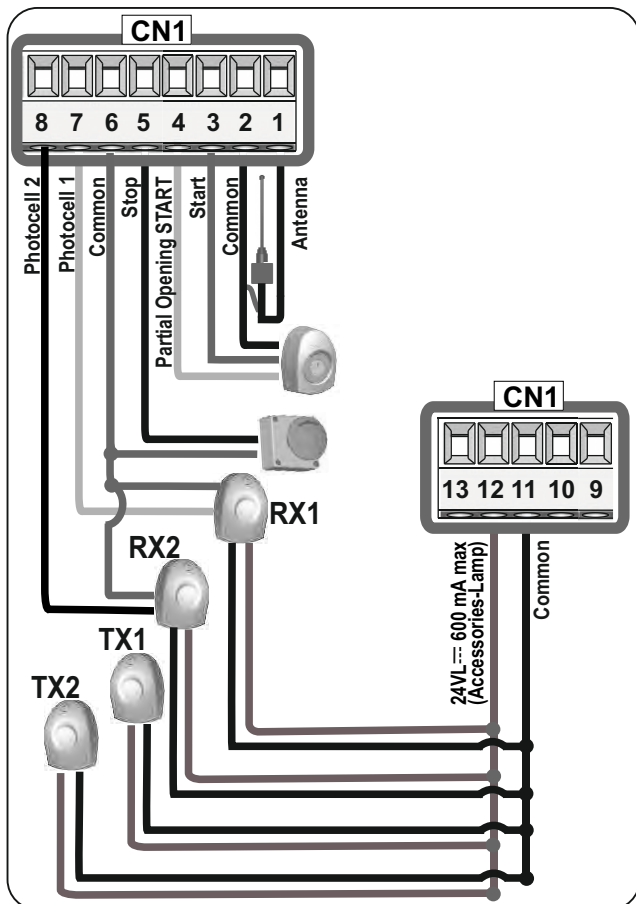

4.1 - START (N.O.)

On clamps 2 and 3

The automation can be opened or closed through an impulse transmitted to this input (via key button, keyboard, etc.). To connect other Start devices (for ex. the magnetic loop) refer to the respective instructions

Note 1: In DEAD MAN logic it is necessary to hold the Start button pressed to open the automation

Note 2: In 2 BUTTONS logic the connected Start device only performs the opening

4.2 - PARTIAL OPENING START (N.O.)

On clamps 2 and 4

The input allows to obtain the partial opening. It is possible to manage the opening space through the **menu-90** or through the JOLLY 3. It is also possible to manage the partial opening pause time through the **menu-91**

Note 1: In 2 BUTTONS logic, the connected Partial Opening Start device only performs the closing

Note 2: In DEAD MAN logic, it is necessary to hold the Partial Opening Start button pressed to close the gate

Note 3: If this contact is engaged during the pause (eg. Timer), the gate will not close until releasing

4.3 - STOP (N.C.) On clamps 5 and 6

If this button is pressed the engine stops immediately in whatever condition or position it is. A new Start command will be required to restore the movement.

Note: After the Stop command, the engine will always re-start in closing

4.4 - PHOTOCELL 1 AND PHOTOCELL 2

+ = 24V max 600mA (clamp 12) **COM** = 0V (clamp 11)

COM = 0V (clamp 6)

Ph1 = Photocell 1 (clamp 7) **PH2** = Photocell 2 (clamp 8)

Note 1: To perform the self-test, connect the TX positive to the clamp 10 (AUX) and activate the Phototest function on **menu-94**; From the **95-PHOTOTEST** menu it is possible to activate the self-test also on a single photocell, choosing from the menu options.

Note 2: The default settings are: **97-PHOTOCELL 1** = «closing»; **98-PHOTOCELL 2** = «opening»; for further functions and management, see menu-97 and menu-98

4.5 - AUX 24V OPTIONS max 250mA

From **menu 94-24VAUX** or through the JOLLY 3 it is possible to choose when to have voltage on the AUX output. In case of control units with batteries and/or photovoltaic panels, it is advisable to connect the unused accessories (eg. Photocells) to the AUX output and then configure the **menu 94-24VAUX** as «**IN CYCLE AND PHOTOTEST**» so it will be possible to save energy by lowering the power consumption in stand-by and increasing the system autonomy

4.6 - TIMER (N.O.)

On clamp 4 (Partial Opening Start) or on clamp 8 (Photocell 2)

It can be enabled through **menu-92** or via JOLLY 3. It opens and keeps the automation open until it releases the contact. When released, the operator will wait for the pause set then will close again

Note 1: If connected to the Partial Opening Start, this command will also be disabled on the remote control

Note 2: When the timer is active, in the event of a safety intervention, a Start command will be required to reset the movement

Note 3: In case of a power failure and with the gate open, if the TIMER is still active it will cause the gate reclosing; if no longer active, a new Start impulse will be required

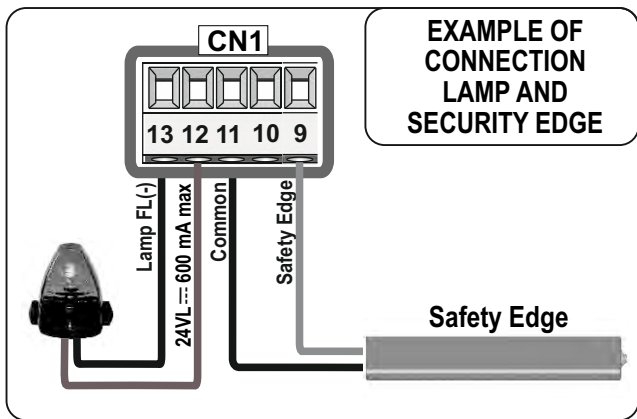

4.7 - 24V ~ FLASHING LIGHT - MAX 3W

On clamps 12 and 13

It warns of the gate movement by performing 1 blink per second on opening, 2 blinks per second on closing and remaining on steady during pause. Through the flashing light it is also possible to read the alarm signals linked to the Stop, Photocell1, Photocell2 and Edge devices. From menu **86-FLASHING LIGHT** or JOLLY3 it is possible to modify its functions.

Furthermore it is possible to manage the pre-flashing function from menu 85- PRE-FLASHING

4.8 - SECURITY EDGE

On clamps 9 and 11

If activated, the safety edge opens the contact causing a partial inversion of the motion both in opening and closing. The function can be managed from menu **100-SECURITY EDGE 1** and **102-EDGE 1 DIRECTION**

Note 1: among the **menu-100** options there is the **8K2 balanced edge** (single or double): the edge contact will be controlled by a specific resistance value which detects any possible short-circuit of the device. If the device is unbalanced, a specific alarm will appear on the display

Note 2: the safety edge functions can also be managed through the JOLLY 3

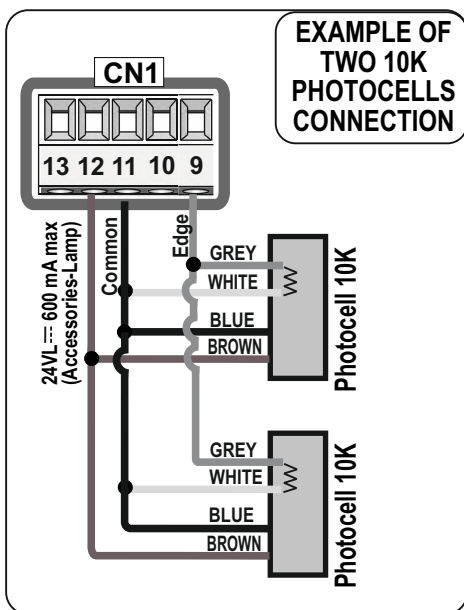

4.9 - 10K SINGLE OR DOUBLE PHOTOCELL

On clamps 9 and 11

If one or two 10K photocells are connected, the menu **100-SECURITY EDGE 1** must be set on the respective function; 10K photocell will work according to the settings of menu **97-PHOTOCELL 1** (or menu **98-PHOTOCELL 2** in case of two 10K photocells)

Note1: The 10K photocell gives additional protection even in the event of a short circuit on the cables

SINGLE OR DOUBLE PHOTOCELL SETTINGS

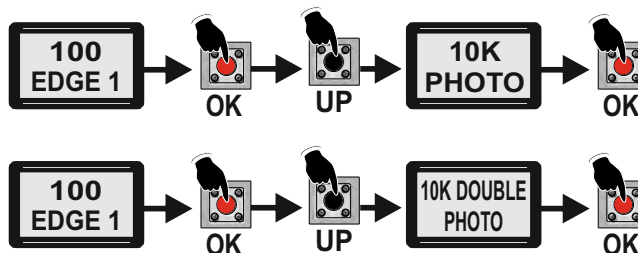

EXAMPLE OF 10K PHOTOCELL AND BUZZER CONNECTION

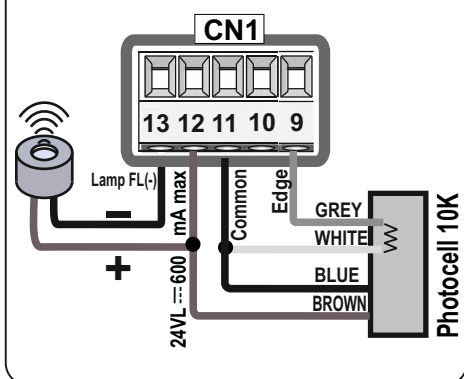

4.10 - BUZZER 24V ~

On clamps 12 and 13

The Buzzer is a sound alarm that can be used as a security device. Use a self-oscillating 24V ~ and 100 dB Buzzer

The Buzzer can be connected instead of the flashing light and it is necessary to set on **«BUZZER»** in the menu **86-FLASHING LIGHT**

The Buzzer will activate after 2 consecutive interventions of the anti-crushing protection; to reset it press the STOP button;

In any case, the sound of the Buzzer turns off automatically after 5 minutes and the automation will stand waiting for a new command



IF BUZZER DOES NOT WORK, BE SURE THAT MENU 86-FLASHING LIGHT IS SET ON «BUZZER»

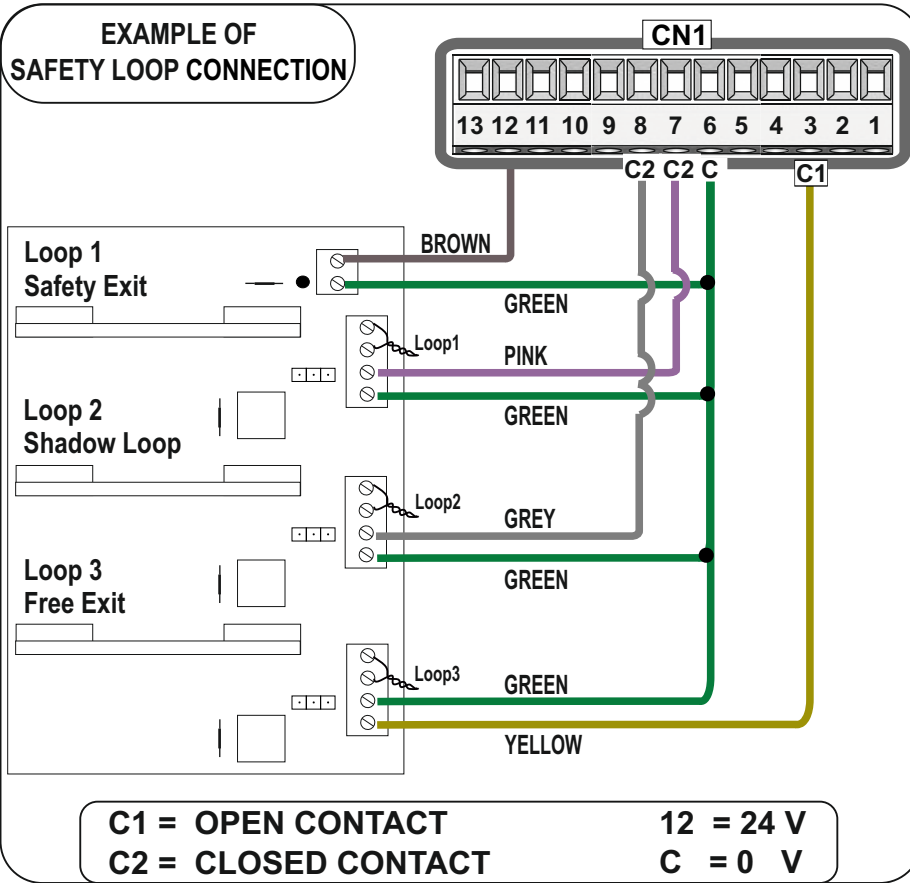

4.11 - SAFETY LOOP

Safety Exit Loop (Loop 1)

Connection scheme of the 1 reader loop detector

7 = Photocell 1 contact (N.C.)
6 = Common

Shadow Loop (Loop 2)

Connection scheme of the 2 readers loop detector

8 = Photocell 2 contact (N.C.)
6 = Common

NOTE: Menu 98-PHOTOCELL 2 must be set on «SHADOW LOOP»

Free Exit Loop (Loop 3)

Connection scheme of the 1 reader loop detector

3 = Start contact (N.O.)
6 = Common

4.12 - MAGNETIC LOCK

On clamps 10 and 11

ATTENTION: set menu 94-24V AUX on «NEGATIVE BRAKE» before connecting the MagLock
It is possible to connect a magnetic lock (MagLock) through the Relay card code 23105340 (or old model code 54020285) to the control unit and to the external power supply (12V/24V DC power supply in case of 12V/24V lock or to 230V power supply in case of 230V lock)

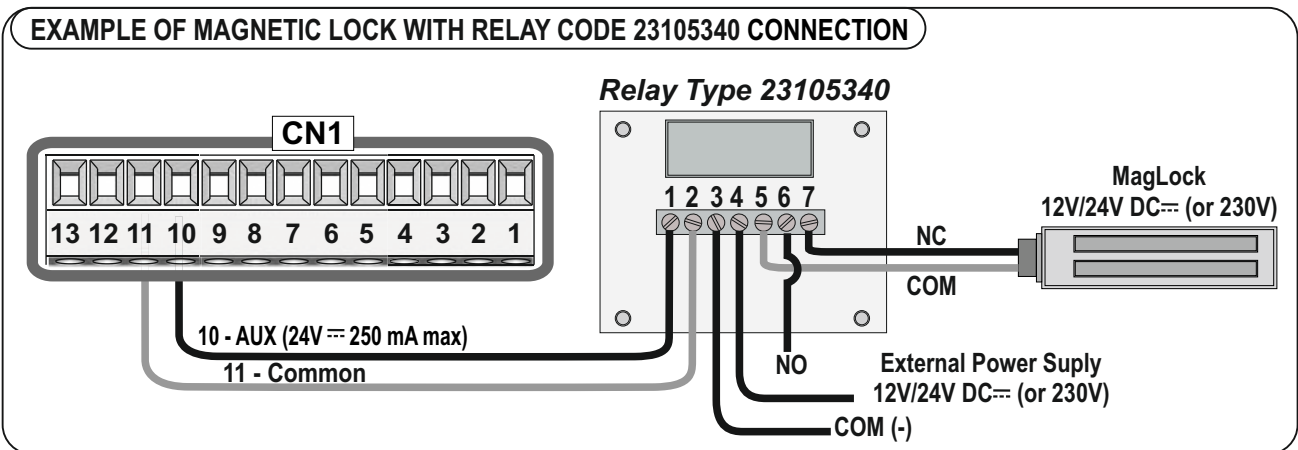

EXAMPLE OF MAGNETIC LOCK WITH RELAY CODE 54020285 CONNECTION

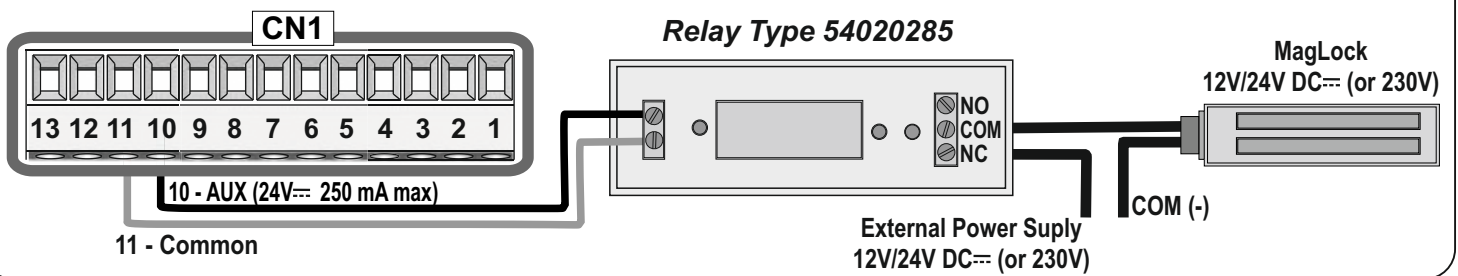

EXAMPLE OF EXTERNAL RECEIVER CONNECTION

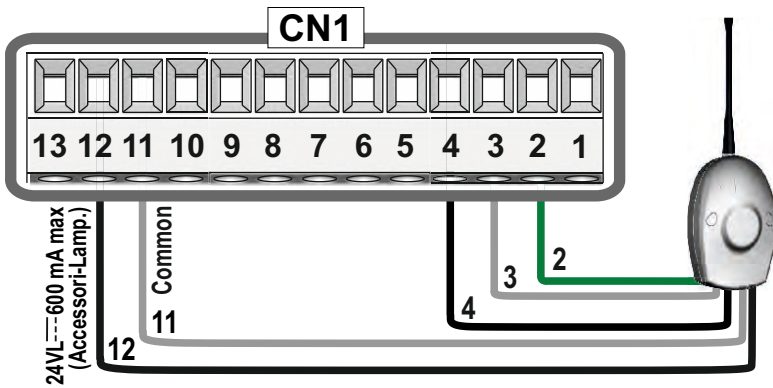

4.13 - EXTERNAL RECEIVER

An external receiver can be connected to the control unit according to the connection diagram. For more details on connections and functionalities of the external receiver, refer to the relative instruction manual

4.14 - LATCH OPENING OR LATCH CLOSING BUTTON

On clamps 4 and 6

A button for the Latch Opening or Closing function can be connected to the control unit

To activate it, connect the N.O. contact on the Partial Opening Start (so this function will be disabled). Through the **menu 118-LATCH** it is possible to choose between the various Latch options.

To deactivate the Latch function, press again the button used for its activation

LATCH OPENING: opens and keeps the automation open. If active, no other type of Start command is accepted until the function is deactivated

LATCH CLOSING: closes and keeps the automation closed. If active, no other type of Start command is accepted until the function is deactivated

Note 1: The Latch function can also be enabled on the second channel of the remote control; see paragraph 16.1 for details

Note 2: The Latch function can also be enabled through the SEACLOUD. Please refer to the SEACLOUD instructions for more details

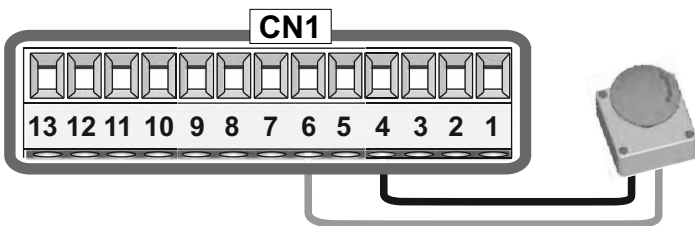

LATCH OPENING OPENS AND KEEPS OPEN

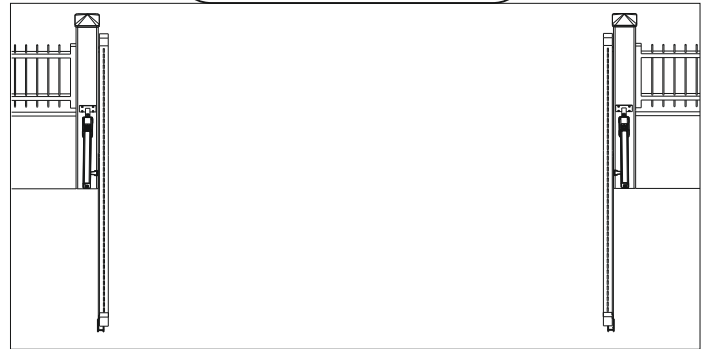

NO OTHER COMMAND IS ACCEPTED

LATCH CLOSING CLOSSES AND KEEPS CLOSED

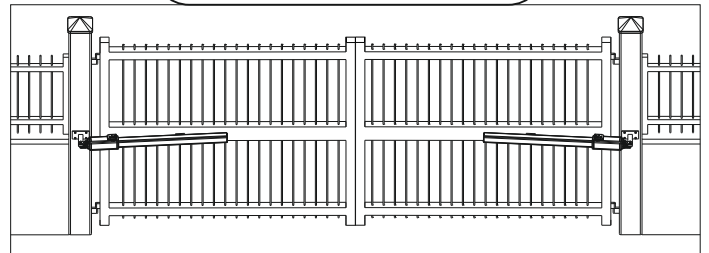

NO OTHER COMMAND IS ACCEPTED

5 - CONNECTIONS ON CN2

EXAMPLE OF LIMIT SWITCH CONNECTION

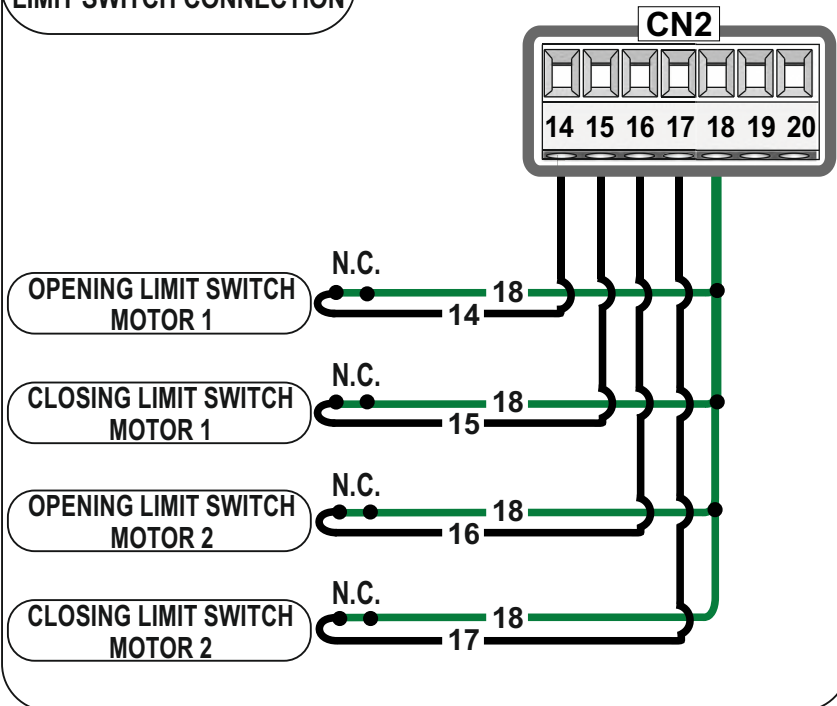

5.1 - LIMIT SWITCH

Do not use jumper wires on limit switches if not connected. For the limit switch function both the closing and the opening limit switches are required.

It is also possible to activate the anti-intrusion function: this function requires at least one limit switch, which, when released, forces the motor to re-close



For the correct operation of the limit switches the correspondence between the direction of motors movement and that of the limit switches involved is required

NOTE:

In menu **104-SELECT LIMIT SWITCH** it is possible to choose whether to work with the opening limit switch only or with the closing one only or with both

EXAMPLE OF CONNECTION ELECTRIC LOCK

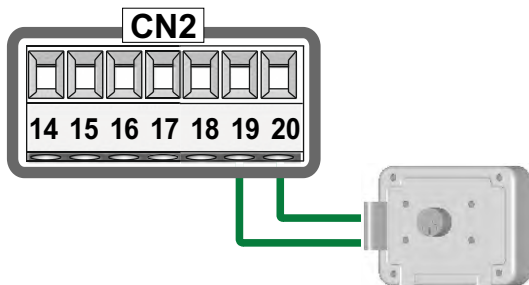

5.2 - ELECTRIC LOCK

On clamps 19 and 20

An Electric Lock (12V $\overline{\text{=}}$ 15W max) can be connected

Through menu **77-LOCK TIME** it is possible to adjust the electric lock release time from 0 to 5 seconds

Through menu **78-LOCK** it is possible to select when to activate the electric lock, if only in opening, only in closing or in both directions

6 - CONNECTIONS ON CN3

6.1 - MOTORS POWER SUPPLY CONNECTIONS

M1 Motor 1
Motor 1 connection output
M+ = OPEN/CLOSE
M- = CLOSE/OPEN

M2 Motor 2
Motor 2 connection output
M+ = OPEN/CLOSE
M- = CLOSE/OPEN

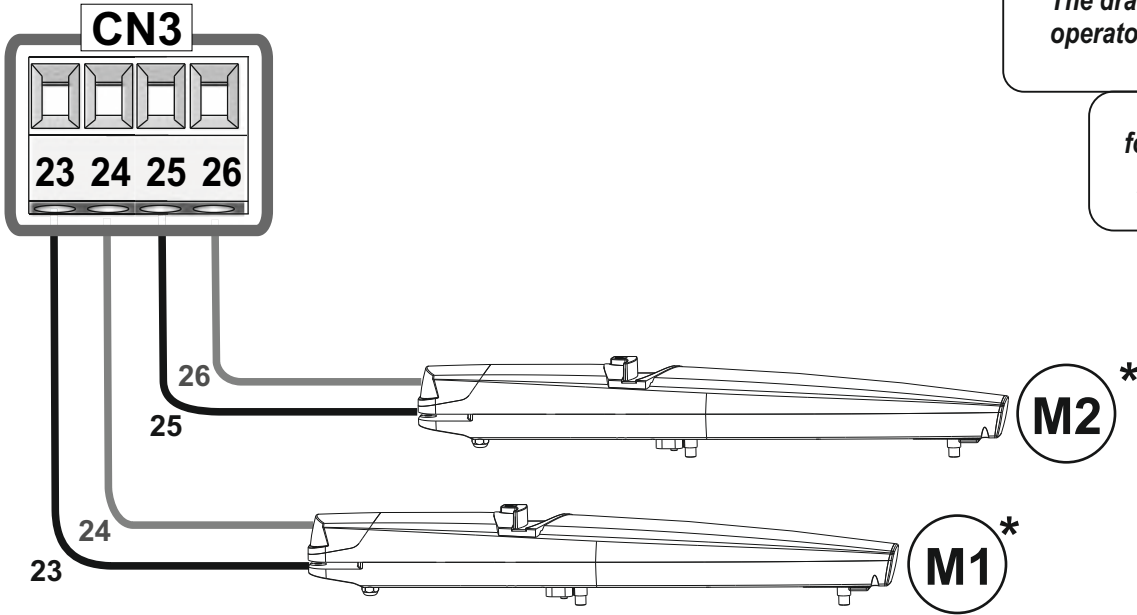

** The drawing shows two external operators for swing gate only as an exemple*

Caution:
for the connection to the power grid refer to the regulations in force

Fuse 3,6A delayed on 230V~ power supply
Fuse 6,3A delayed on 115V~ power supply

Power Supply Input
Power supply connection input
P = PHASE
N = NEUTRAL
G = GROUND

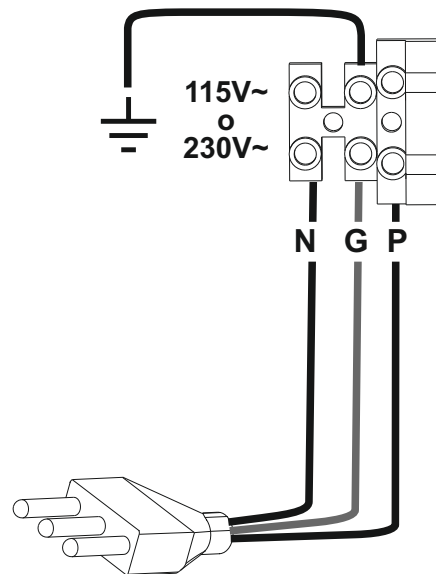

NOTE:
It is recommended to use a 10A differential switch to protect the power supply system

7 - CONNECTIONS ON CN5

7.1 - SWITCHING CONNECTION

It is possible to connect a switching device to change the supply voltage of control unit
 If the main supply is 115V 60Hz, move the side switch to 115V. The switching power supply with voltages ranging from 90V to 164V, keeps the output constant on 30V

Caution: for the connection to the power grid refer to the regulations in force

Power Supply Input

Power supply connection input
P = PHASE
N = NEUTRAL
G = GROUND

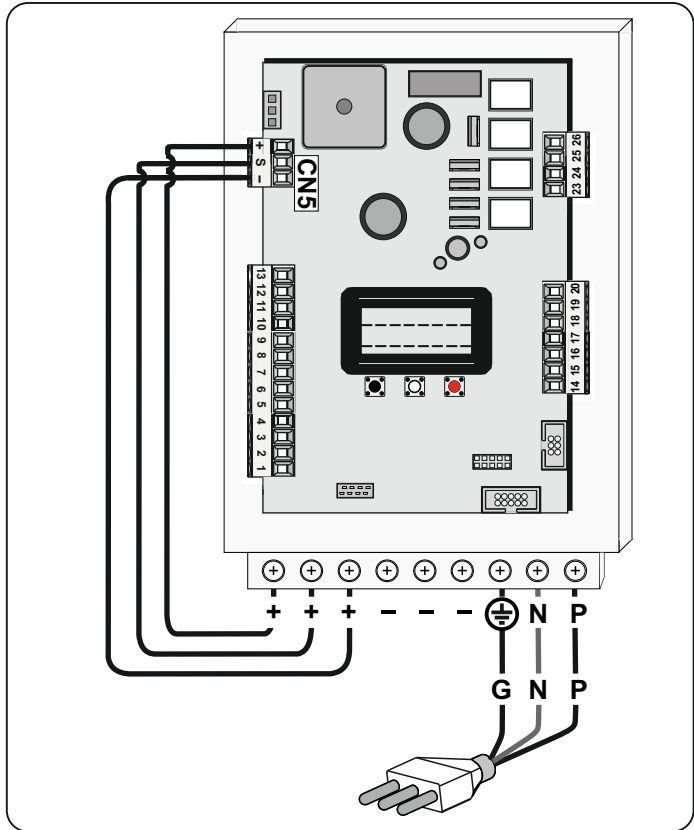

7.2 - BATTERY CONNECTION WITH BATTERIES CHARGER UNIT

It is possible to power the control unit using **two 12V batteries connected in series (24V Pb 1.2Ah min)**, connected, in turn, to the battery charger management unit and this latter connected to the solar panel.

WARNING: Always use the batteries charger unit to connect the batteries

Note: If you use the E-SUNQ unit, you must cut the cable as shown in the figure and reconnect it on the CN5 connector, respecting the correspondences + S -

BATTERY CURRENT (mA)	BATTERY (Ah)
800	12 o 16
360	7
200	2

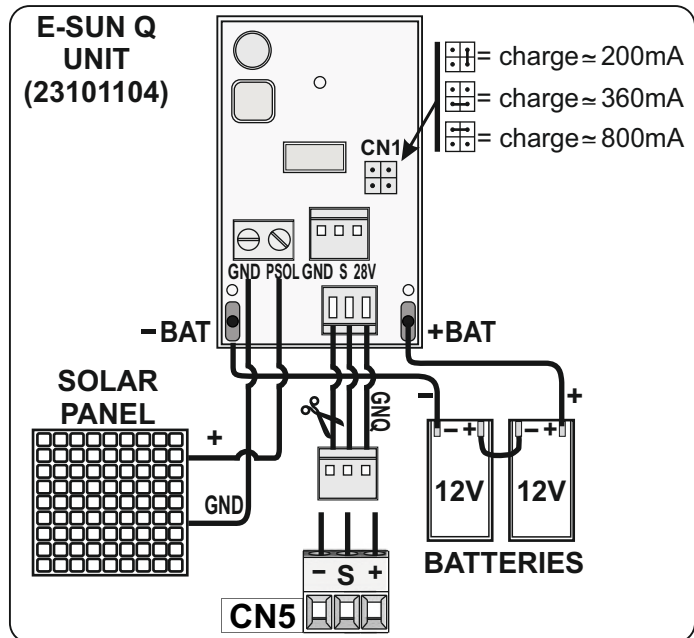
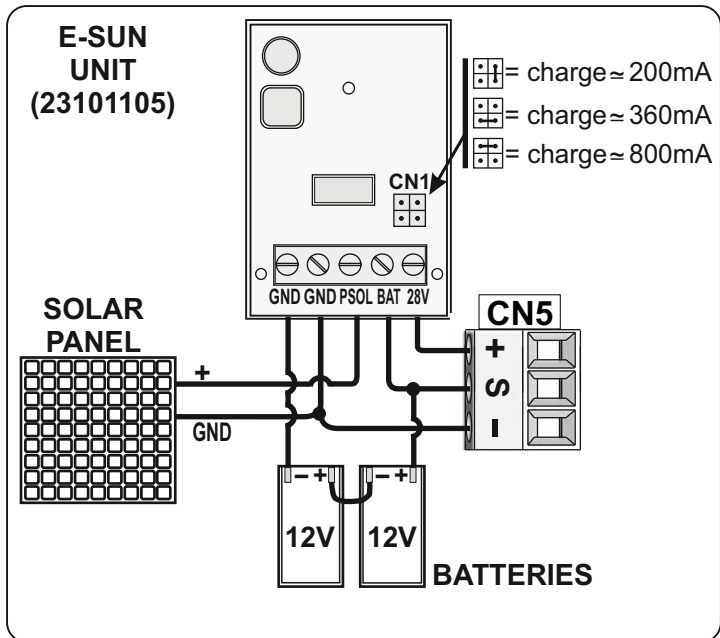

8 - EXTERNAL CONNECTIONS

8.1 - «SEM 2» MANAGEMENT UNIT CONNECTIONS

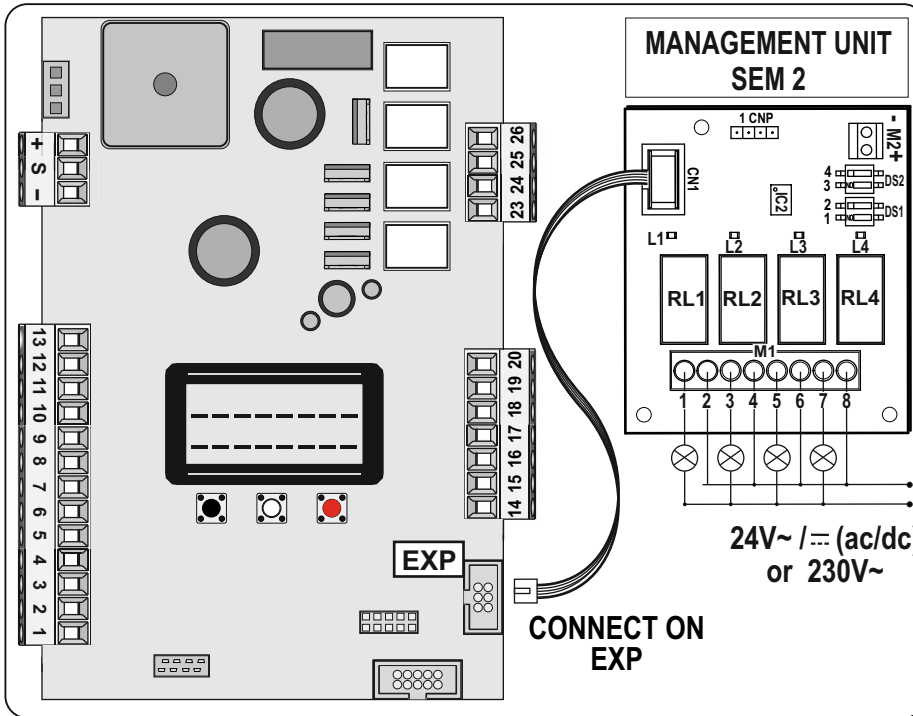

The «SEM 2» management unit can be connected through the **EXP** connector

The SEM 2 unit manages:

- The **TRAFFIC LIGHT** functions
- The **COURTESY LIGHT** functions
- The **VERTICAL ELECTRIC LOCK** functions
- The **POSITIVE AND/OR NEGATIVE ELECTRIC BRAKE** functions
- The **LIMIT SWITCH** status

For further details on connections, functions or specifications of the «SEM 2» unit, refer to the relevant TECHNICAL INSTRUCTIONS

8.2 - LIMIT SWITCH WITH «LSE» MANAGEMENT UNIT CONNECTION

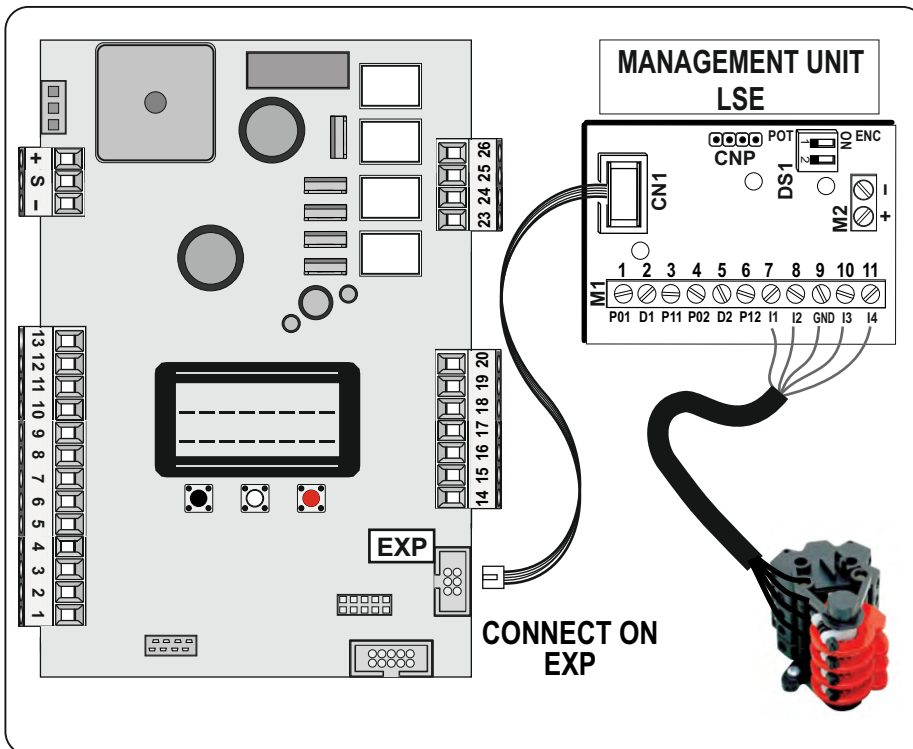

The «LSE» management unit can be connected through the **EXP** connector

With the «LSE» management unit it is possible to manage 4 additional limit switches to set the slowdown starting points

WARNING: The opening and closing limit switches must be connected to the electronic control unit

To manage the additional limit switches refer to **104-SELECT LIMIT SWITCH**

For further details on connections, functions or specifications of the «LSE» unit, refer to the relevant TECHNICAL INSTRUCTIONS

8.3 - «I/O SURGE PROTECTOR» CIRCUIT CONNECTION

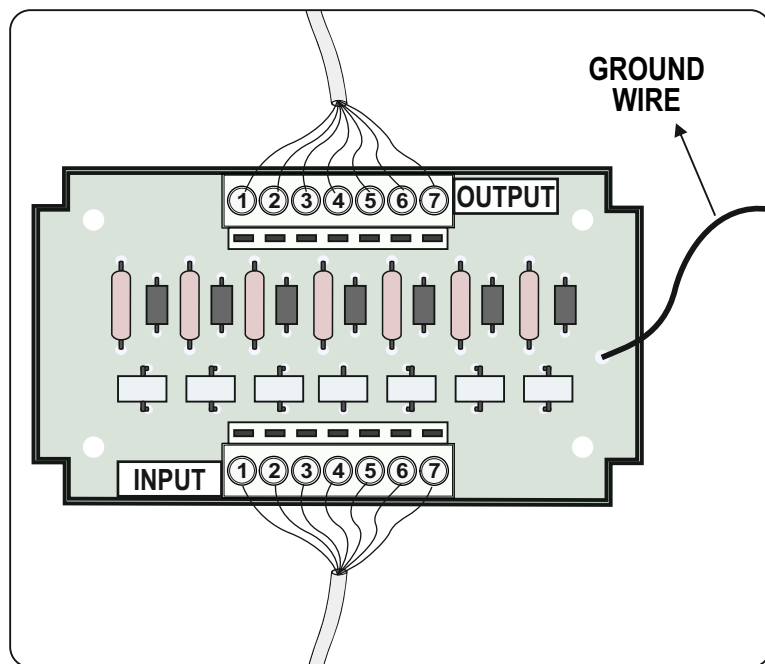

OUTPUT CONNECTIONS ON CONTROL UNIT	
1	24V DC ACCESSORIES
2	CONTACT 1 (Eg. PHOTOCCELL)
3	CONTACT 2 (Eg. SECURITY EDGE)
4	CONTACT 3 (Eg. START)
5	CONTACT 4
6	CONTACT 5
7	CONTACT 6

INPUT ACCESSORIES CONNECTIONS	
1	24V DC ACCESSORIES
2	CONTACT 1 (Eg. PHOTOCCELL)
3	CONTACT 2 (Eg. SECURITY EDGE)
4	CONTACT 3 (Eg. START)
5	CONTACT 4
6	CONTACT 5
7	CONTACT 6

It is possible to connect the «**SURGE PROTECTOR**» device, to protect up to 6 inputs + 24V power supply from overvoltages due, for example, to the lightning strikes.
Simply connect the cable of the accessory to be protected to the **INPUT** of the SURGE PROTECTOR circuit and then, from the corresponding number on the **OUTPUT** terminal block, connect the cable to the control unit

NOTE: connect the common and the power supply negative directly on the control unit

9 - ADDITIONAL FUNCTIONS

9.1 - AMPEROMETRIC MANAGEMENT

The control unit is equipped with an obstacle detection system, which works only for electro-mechanical motors, which allows the reversing on obstacle and the automatic detection of the mechanical stop
It allows to adjust the torque value (the inversion force on obstacle) through the menus:

- 28-ENGINE OPENING TORQUE 1**
- 29-MOTOR CLOSING TORQUE 1**
- 30-MOTOR OPENING TORQUE 2**
- 31-MOTOR CLOSING TORQUE 2**

It allows to adjust the sensitivity for single leaf or single direction (opening or closing) through the menus:

- 33-MOTOR OPENING SENSITIVITY 1**
- 34-MOTOR CLOSURE SENSITIVITY 1**
- 35-MOTOR OPENING SENSITIVITY 2**
- 36-MOTOR CLOSURE SENSITIVITY 2**

NOTE: In case of power failure, after the power supply restoring the first operation will be performed with the set speed in order to search for the end-of-stroke mechanical stops

10 - PRELIMINARY

WARNING

Starting from the software version to which this technical instruction refers, 03.00, the electronic control board is equipped with **the new BINGO display** with different functions than the previous version. If you have a control board with the **old version display**, consult the manual of the previous revision

NEW BINGO DISPLAY
STARTING FROM SOFTWARE REVISION 03.00

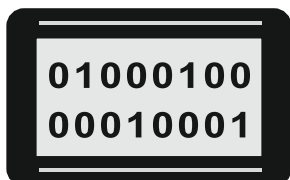

OLD DISPLAY
CONSULT PREVIOUS MANUAL REVISION

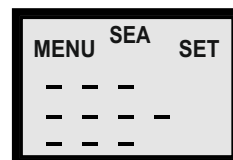

When a new or a just reset control unit is powered on, the display shows the software revision first then it shows the **INPUT STATUS** after 5 seconds. The latter will be the default display view when an already programmed unit is turned on

NEW CONTROL UNIT OR AFTER RESET

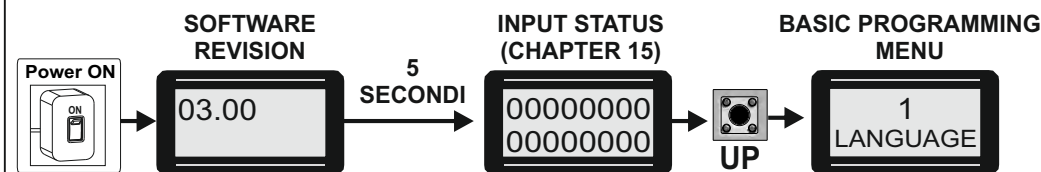

ALREADY PROGRAMMED CONTROL UNIT

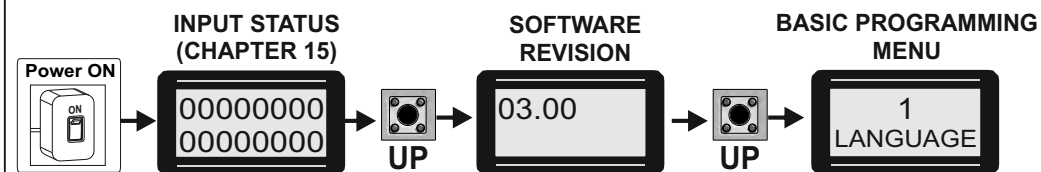

10.1 - BASIC PROGRAMMING MENU AND SPECIAL MENU

The control unit is equipped with a **basic programming menu** which can be accessed by through the procedure above indicated when the unit is switched on

The control unit is also equipped with a **special menu** that allows the setting of various parameters and the configuration of the accessories.

To access **THE SPECIAL MENU** choose one of the following 2 procedures:

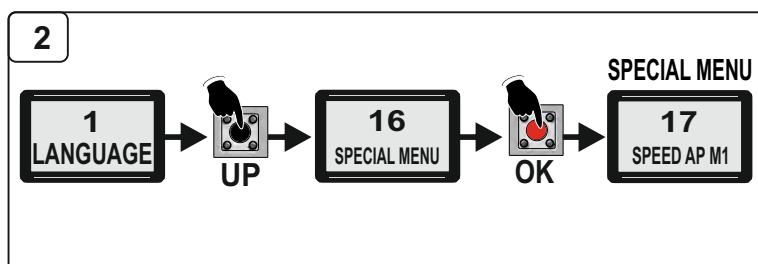
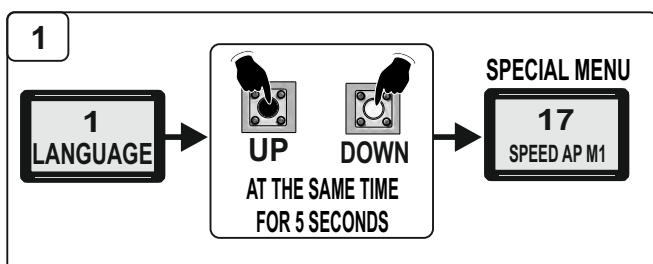

11 - QUICK START

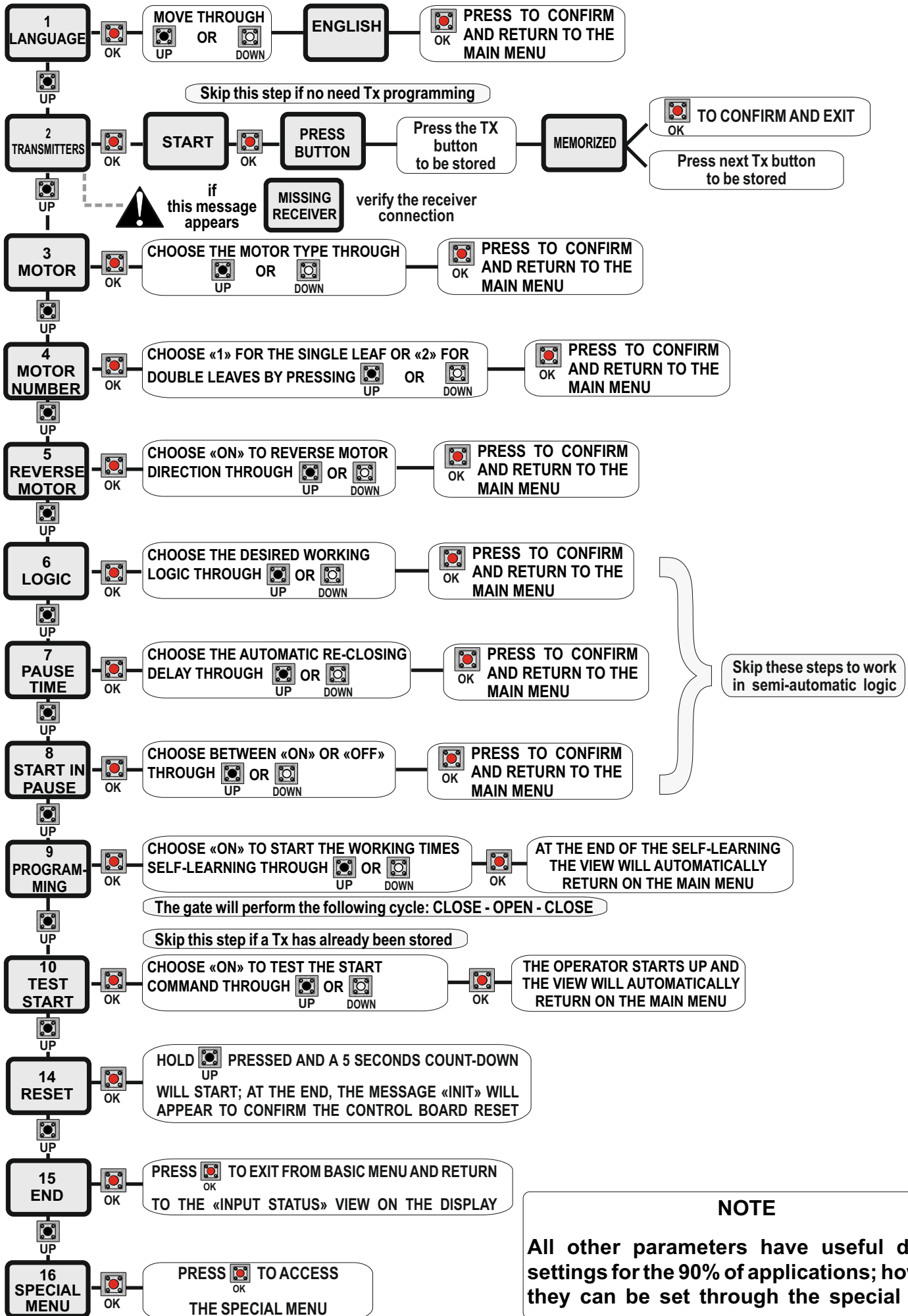

12 - WORKING TIMES SELF-LEARNING

- ! - Use a jumper wire on SAFETY EDGE contact if it not used (see chapter 3)
- It is not necessary to use jumper wires on Limit switch, Photocells or Stop if they are not used
- Check the correct operation of all accessories (Photocells, Push buttons etc.)

PRELIMINARY NOTES:

- Set leaf delay if necessary
- Adjust the self-learning speed if necessary
- **If one or both motors perform the first learning starting in opening, then remove the power supply and reverse the cables of the motor (s) starting in opening (or, through control board, select ON on menu 5-REVERSE MOTOR) then repeat the procedure**

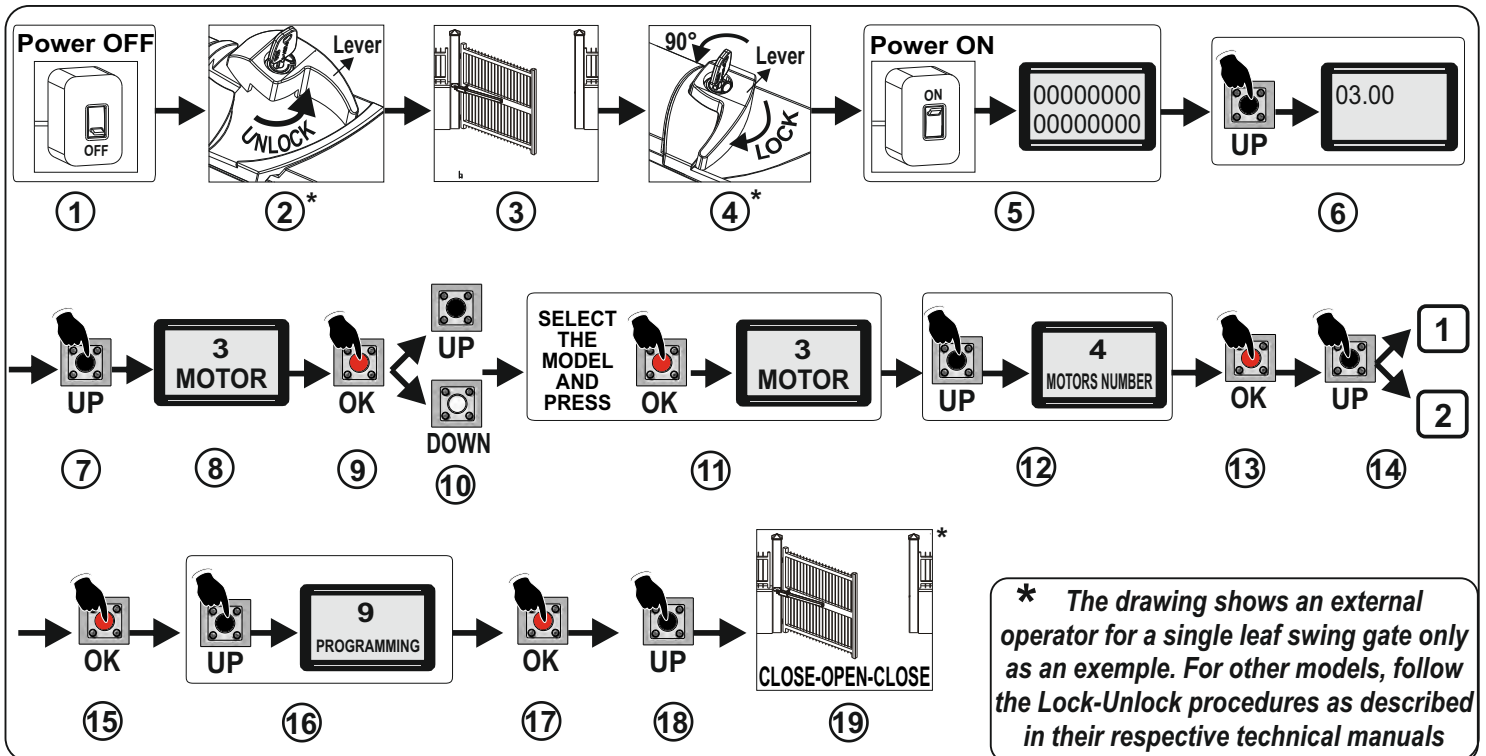

- Turn off the power supply
- Unlock the operators
- Manually move the leaf/leaves on halfway
- Restore the mechanical lock
- Power the control unit and the input status will be shown on the display
- Press UP and the current software version will be shown
- Press UP again and access the programming menu
- Pressing UP scrolls to the 3-MOTOR menu
- Press OK to select the 3-MOTORS menu and enter the menu
- Use UP or DOWN to scroll through the options
- Select the model by pressing OK and the display returns to the 3-MOTORS menu
- Use the UP button to scroll to the 4-MOTORS NUMBER menu
- Press OK
- Press UP to choose «1» (1 motor = SINGLE LEAF) or «2» (2 motors = DOUBLE LEAF)
- Press OK to confirm and the display returns to the 4-MOTORS NUMBER menu
- Use the UP button to scroll to menu 9-PROGRAMMING
- Press OK to access the menu
- Press UP to start programming
- The gate automatically performs the cycle: **CLOSE - OPEN - CLOSE** (or, in the case of double leaf: **CLOSE M2 - CLOSE M1 - OPEN M1 - OPEN M2 - CLOSE M2 - CLOSE M1**)

Self-learning completed

13 - OPERATING LOGICS

PRELIMINARY NOTES

1) For the automatic closing it is necessary to set a pause time; through the **menu 7-PAUSE TIME** set a time between 1 second and 240 seconds.

By default this parameter is OFF (semi-automatic logic)

2) It is possible to choose whether or not to accept the Start in pause; on **menu 8-START PAUSE** select ON

By default this parameter is OFF

AUTOMATIC LOGIC

A **START** impulse opens the gate.

A second **START** impulse during the opening will not be accepted.

A **START** impulse during closing reverses the movement

SAFETY LOGIC

A **START** impulse opens the gate.

A second **START** impulse during opening reverses the movement.

A **START** impulse during closing reverses the movement

STEP BY STEP TYPE 1 LOGIC

The **START** impulse follows the **OPEN-STOP-CLOSE-STOP-OPEN** logic

STEP BY STEP TYPE 2 LOGIC

The **START** impulse follows the **OPEN-STOP-CLOSE-OPEN** logic

DEAD MAN LOGIC

The gate will open as long as the **START** opening button is held pressed;

when released the gate stops.

The gate closes as long as the **PARTIAL OPENING START** button is held pressed;

when released the gate stops.

To carry out the complete opening and/or closing cycles it is necessary to hold the respective buttons constantly pressed

2 PUSH-BUTTONS LOGIC

One **START** opens, one **PARTIAL OPENING START** closes.

A closing input will not be accepted during opening.

A **START** command reopens during closing movement while the **PARTIAL OPENING START** (to close) will be ignored

14 - PASSWORD MANAGEMENT

By default the password is disabled. To set a password proceed as follows:

- ① Go on any basic menu number
- ② Press UP and DOWN simultaneously for 5 seconds and access the Special Menu SP
- ③ Scroll using the UP or DOWN buttons to the **112-PASSWORD** menu
- ④ Press OK
- ⑤ Enter a 4-digit password (**WARNING: it is not allowed to set 0000 as a password**) using the UP and DOWN buttons to increase or decrease the digits
Once the first digit has been chosen, confirm with OK then set the next one
- ⑥ Once the last digit has been set, the word «**SURE?**» will appear
- ⑦-A To confirm press OK and the confirmation message «**OK**» will appear on the display; The password will be active as soon as the display shut-down time-out expires or the electronic board is turned off and on again
- ⑦-B Press UP to cancel the operation; the message «**Cancelled**» will appear on the display; then repeat the procedure from the point ⑤

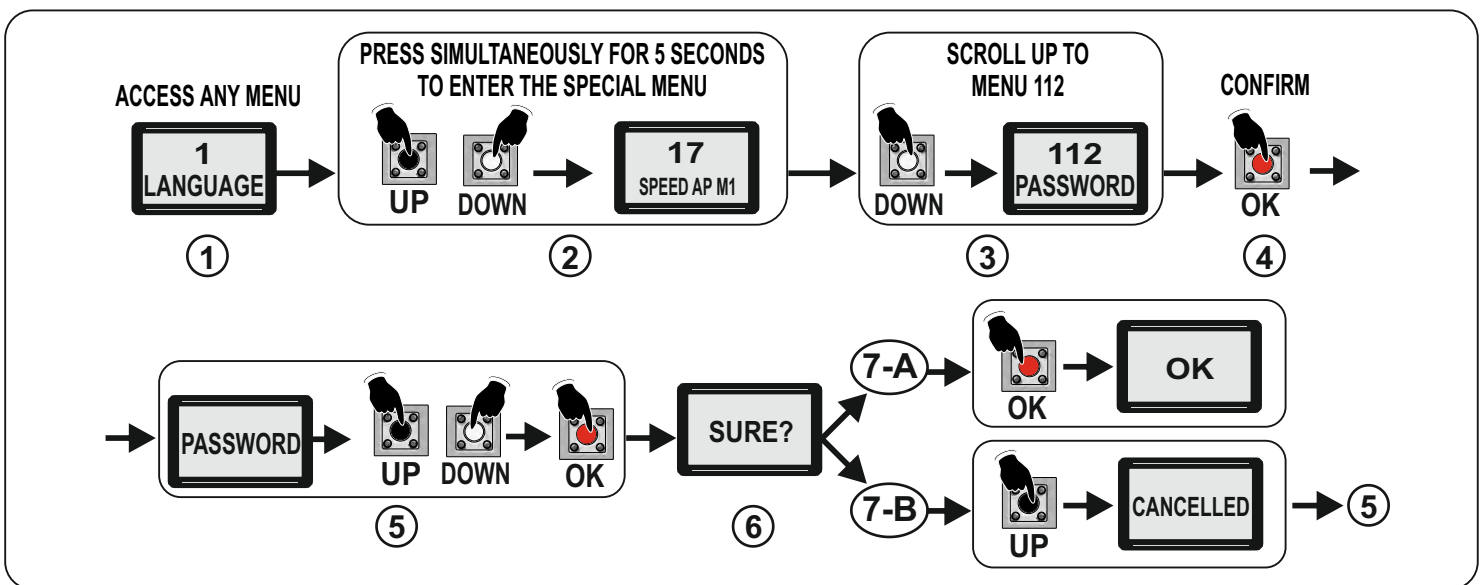

Once the password is activated, **the menus will only be shown but cannot be adjusted**; To unlock the control unit enter the correct password in the 112-PASSWORD Special Menu.

If the password is wrong, the message "**ERROR**" will be displayed

To change the password it is necessary to unlock the control unit first, then repeat the procedure to set a new password.

If You forgot the password, contact the SEA technical assistance; SEA will evaluate whether or not to provide the procedure for the control unit unlocking

NOTE: Password **CANNOT** be set using the JOLLY 3 programmer

15 - INPUT STATUS CHECK AND MANAGEMENT

The input status check menu is displayed at the start of the control unit (for more details see chapter 10). Each input corresponds to a fixed position on the display, according to the diagram below and can be **NORMALLY OPEN (N.O.)** or **NORMALLY CLOSED (N.C.)**

0 = NORMALLY OPEN (N.O.)

1 = NORMALLY CLOSED (N.C.)

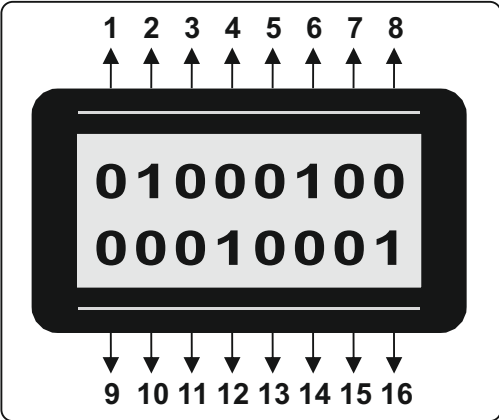



1 START	9 OPENING LIMIT SWITCH MOTOR 1
2 PARTIAL OPENING START	10 CLOSING LIMIT SWITCH MOTOR 1
3 STOP	11 OPENING LIMIT SWITCH MOTOR 2
4 PHOTOCELL 1	12 CLOSING LIMIT SWITCH MOTOR 2
5 PHOTOCELL 2	13 NOT IN USE
6 SAFETY EDGE 1	14 NOT IN USE
7 SAFETY EDGE 2	15 NOT IN USE
8 NOT IN USE	16 NOT IN USE

The symbol «1» lit indicates that, during self-learning, the input status is closed or disabled

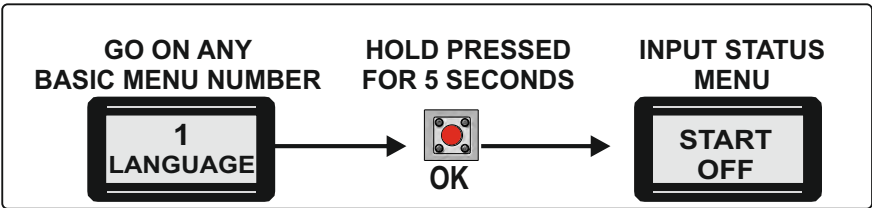
15.1 - ACCESS TO THE INPUTS STATUS MENU AND MANAGEMENT



Access the input status menu and scroll forward or backward through  and ; by scrolling through the inputs, these are shown in their current state: in ON or OFF



Within this management menu it is possible to enable or disable the inputs; for the procedure see the table in the next paragraph (15.2);

The LIMIT SWITCHES inputs and the battery status (0.0V) cannot be managed, but only their current status (ON or OFF) is displayed

 **WARNING**

START and **PARTIAL OPENING START** must be **NORMALLY OPEN (N.O.)** contacts:

If «ON» appears on the display when one of the two command is activated, the input is working
 If «OFF» is displayed even after the command activation, then it is advisable to check the wirings

ALL OTHER CONTACTS ARE NORMALLY CLOSED (N.C.):

If «OFF» appears on the display when a command is activated, the input is working
 If «ON» is displayed even after the command activation, then it is advisable to check the wirings

15.2 - «USER 2 24V DG R1B ALL-IN» INPUT MANAGEMENT MENU

Through this menu it is possible to activate or deactivate the inputs without repeating the self-learning

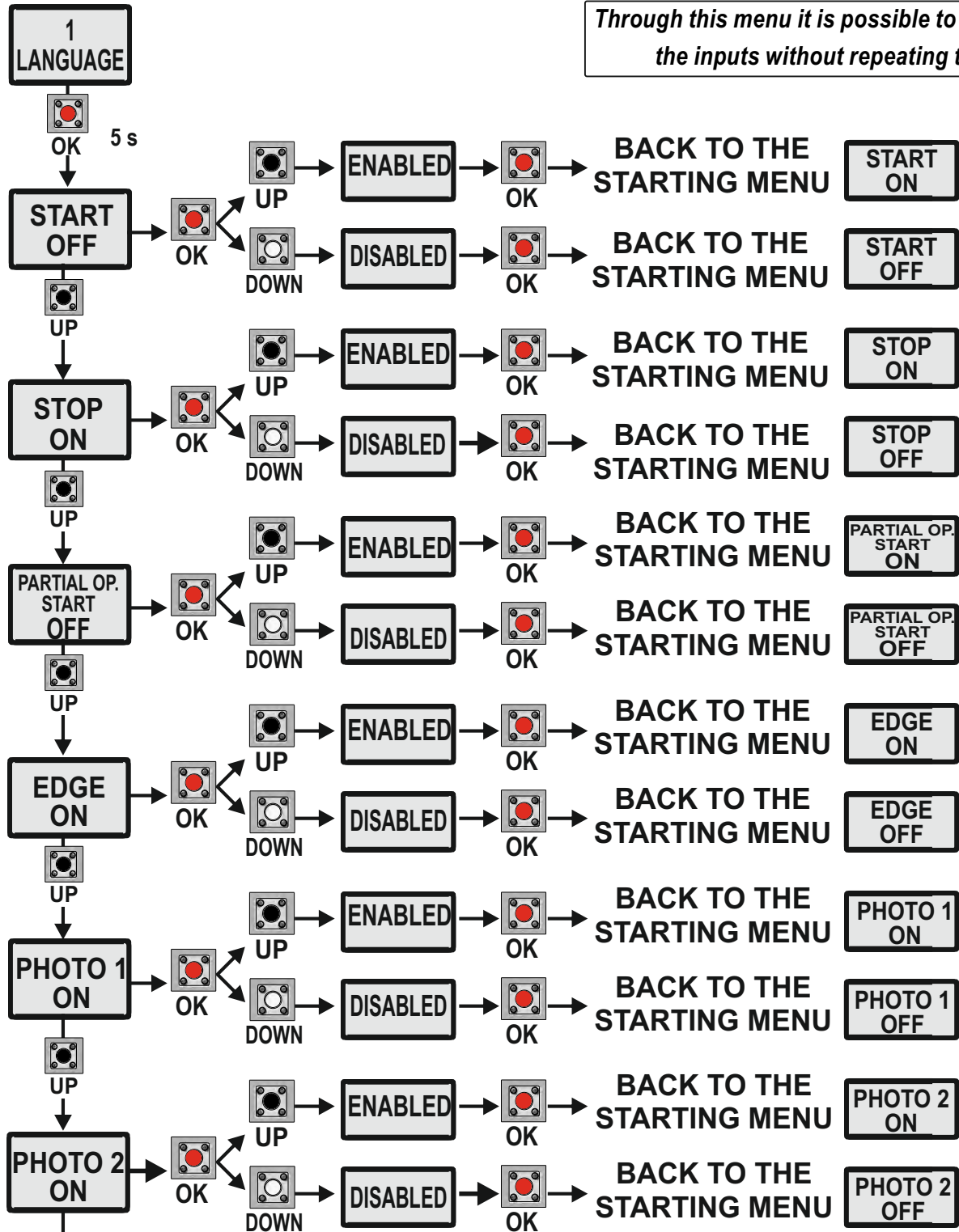

THE FOLLOWING MENUS ONLY DISPLAY THE CURRENT INPUT STATUS;
IT IS NOT ALLOWED TO MAKE CHANGES

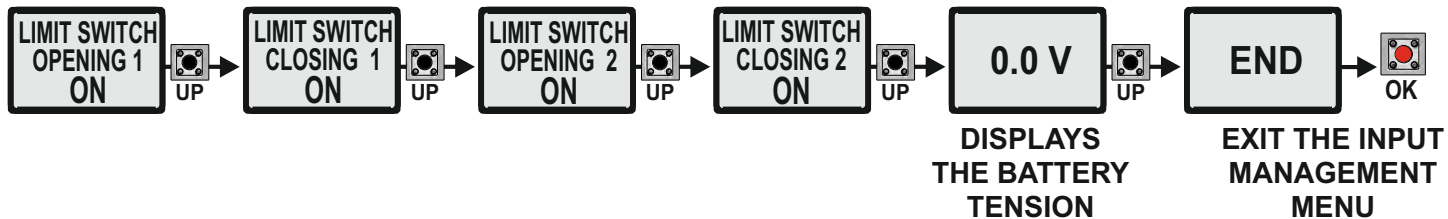

16 - RADIO TRANSMITTERS SELF-LEARNING (RECEIVER ON BOARD)

RX RECEIVER

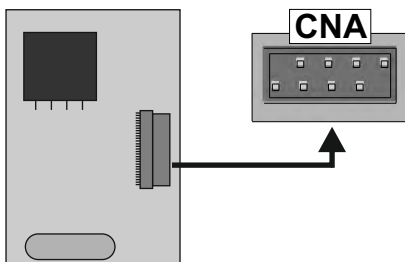

SEA PLUG-IN RECEIVERS	MAX. NUMBER OF USERS
RF UNI	16 USERS Without additional memory 800 USERS With MEMO additional memory
RF UNI PG (Old Model) (non-extractable memory)	100 USERS Fix Code 800 USERS Roll Plus
RF UNI PG (New Model) (extractable memory)	800 USERS Fix Code 800 USERS Roll Plus

PRELIMINARY NOTES:

- **With the control unit OFF**, check if the RECEIVER module is correctly connected to the CNA connector
- Power up the card and program the radio transmitters before connecting the antenna
- The RF UNI and RF UNI PG modules allow the use of both ROLL PLUS SERIES and FIXED CODE radio transmitters
- Perform the radio transmitters learning **only with closed gate and stopped motor**
- It is possible to store up to 2 of the available functions
- The START function must ALWAYS be assigned
- If the second function assigned will be modified later, then all the radio transmitters will acquire this last function on the second channel



WARNING

The first stored radio transmitter will determine the coding of the following ones: if the first radio transmitter is stored as ROLLING CODE, then all the following radio transmitters must be stored as ROLLING CODE (FIX CODE storing will not be accepted). Vice versa, if the first radio transmitter is stored as a FIX CODE, then all the following radio transmitters must be stored as FIX CODE (ROLLING CODE storing will not be accepted)

STORING OF A ROLLING CODE RADIO TRANSMITTER:

Follow the procedures on the next paragraph (16.1) for programming the remote control different buttons. When choosing the remote control button to be programmed, it is required to «*Press the Button*»; **to store THE FIRST REMOTE CONTROL in ROLLING CODE the button must be pressed TWICE IN SUCCESSION; for the subsequent remote controls it is sufficient to press it ONLY ONCE as required by the procedure**

STORING OF A FIX CODE OR ROLLING CODE PLUS RADIO TRANSMITTER:

Follow the procedures on the next paragraph (16.1) for programming the remote control different buttons; **to store REMOTE CONTROLS in FIX CODE or ROLLING CODE PLUS the button must be pressed ONCE as required by the procedure (for both the first remote control and the following ones)**

FOR THE INSTALLER

On 2-REMOTE CONTROLS menu you can see the serial number of the stored radio transmitters; It is advisable to create a table* as reminder of the serial numbers of the Rolling Code remotes assigned to the various customers, in order to have an easier management of all transmitters

Memory Location	TX Button	1	2	3	4	Serial Number	Customer
	0	1	2	3			
0							
1							
2							
3							

**exemple of table*

16.1 - REMOTE CONTROLS PROGRAMMING TABLE

PROGRAMMING MENU

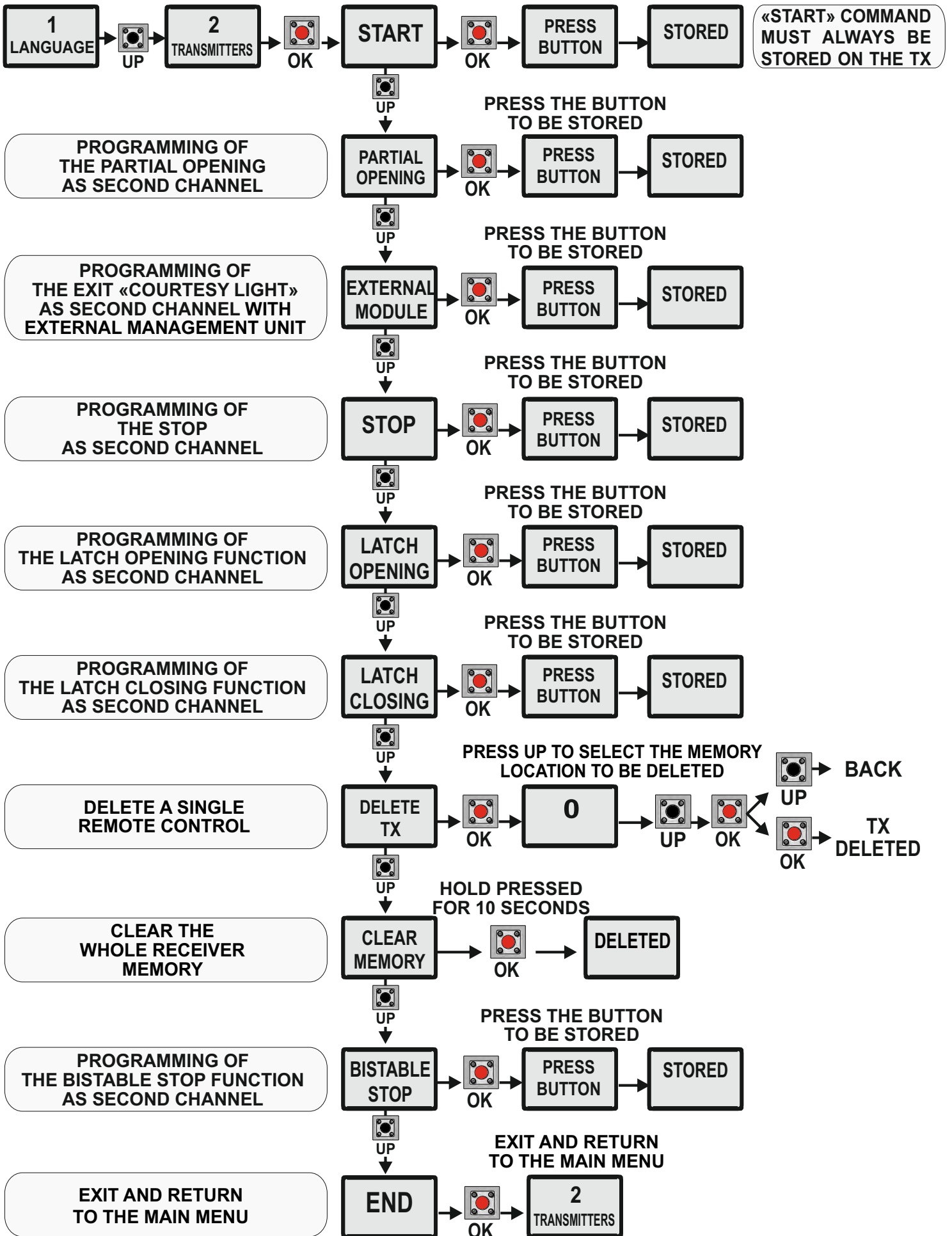

USER 2 24V DG R1B "ALL - IN" MENU FUNCTIONS TABLE

MENU		SET	DESCRIPTION	DEFAULT	NOTE
1	LANGUAGE	<i>Italiano</i>	Italian	<i>English</i>	
		<i>English</i>	English		
		<i>Français</i>	French		
		<i>Español</i>	Spanish		
		<i>Dutch</i>	Dutch		
		<i>Polish</i>	Polish		
2	TRANSMITTERS	<i>Start</i>	Start	<i>Start</i>	
		<i>Partial opening</i>	Partial opening		
		<i>External module</i>	External module		
		<i>Stop</i>	Stop		
		<i>Latch opening</i>	One impulse opens and keep open. A second impulse restore the movement	<i>Partial Opening</i>	
		<i>Latch closing</i>	One impulse closes and keep closed. A second impulse restore the movement		
		<i>Delete a transmitter</i>	Delete single transmitter		
		<i>Clear memory</i>	Delete transmitter memory		
		<i>Bistable Stop</i>	Pressed once, it stops the gate. Pressed twice, it reactivates the START input		
		<i>End</i>	Exit transmitters menu		
3	MOTORE	33- FLIPPER - GER	Electromechanical operators for swing gates	-----	
		34- FIELD	Electromech. in-ground operator for swing gates		
		35- SURF - KITE - ALPHA	Electromechanical operators for swing gates		
		36- BETA	Electromechanical operator for swing gates		
		37- B-600	Electromechanical operator for swing gates		
4	MOTORS NUMBER	<i>From 1 to 2</i>	Allows to set the number of motors to be managed	<i>1</i>	
5	REVERSE MOTOR	<i>On</i>	It reverses the opening with the closing or viceversa (Note: both motors and limit-switches are reversed)	<i>Off</i>	
		<i>Off</i>	Off		
6	LOGIC	<i>Automatic</i>	Automatic	<i>Auto- matic</i>	
		<i>Open-stop-close-stop-open</i>	Step by step type 1		
		<i>Open-stop-close-open</i>	Step by step type 2		
		<i>2 button</i>	Two buttons		
		<i>Safety</i>	Safety		
		<i>Dead man</i>	Dead man		
7	PAUSE TIME	<i>Off</i>	Disabled (semi-automatic logics)	<i>Off</i>	
		<i>1 240</i>	Setting from 1 second to 4 minutes		
8	START IN PAUSE	<i>Off</i>	The Start is not accepted during pause	<i>Off</i>	
		<i>On</i>	The Start is accepted during pause		
9	PROGRAMMING	<i>Off On</i>	Times learning start	<i>Off</i>	
10	TEST START	<i>Off On</i>	Start command	<i>Off</i>	
14	RESET	A count-down of 5 seconds will start by holding pressed the UP button; at its end "INIT" will appear on the display as confirmation of the control board reset			
15	END	<i>Press OK to return to the display of the firmware version and to the one of inputs state</i>			
16	SPECIAL MENU	<i>Press OK to enter the special menu</i>			

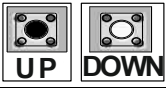



SPECIAL MENU

PRESS AT THE SAME TIME FOR 5 SECONDS TO ENTER OR TO EXIT THE SPECIAL MENU

USER 2 24V DG R1B "ALL - IN" SPECIAL MENU FUNCTIONS TABLE

For entering into the special menu move on one of the menu and press the UP and DOWN buttons at the same time for 5 seconds
 For exiting the special menu press END or move on one of the menu and press the UP and DOWN at the same time for 5 seconds

SP MENU		SET		DESCRIPTION	DEFAULT	NOTE
17	OPENING SPEED M1	30	100	Setting from 30 to 100	75	
18	CLOSING SPEED M1	30	100	Setting from 30 to 100	75	
19	OPENING SPEED M2	30	100	Setting from 30 to 100	75	
20	CLOSING SPEED M2	30	100	Setting from 30 to 100	75	
21	SLOWDOWN SPEED IN OPENING M1	30	100	Setting from 30 to 100	30	
22	SLOWDOWN SPEED IN CLOSING M1	30	100	Setting from 30 to 100	30	
23	SLOWDOWN SPEED IN OPENING M2	30	100	Setting from 30 to 100	30	
24	SLOWDOWN SPEED IN CLOSING M2	30	100	Setting from 30 to 100	30	
25	LEARNING SPEED	30	100	Setting from 30 to 100	50	
26	LEAF DELAY IN OPENING	Off	6	Setting from OFF to 6 seconds	3	
27	LEAF DELAY IN CLOSING	Off	20	Setting from OFF to 20 seconds	3	
28	OPENING TORQ 1	10	100	Opening torque Motor 1: by increasing the torque, more strenght will be required to execute the inversion in case of obstacle	70	
29	CLOSING TORQ 1	10	100	Closing torque Motor 1: by increasing the torque, more strenght will be required to execute the inversion in case of obstacle	70	
30	OPENING TORQ 2	10	100	Opening torque Motor 2: By increasing the torque, more strenght will be required to execute the inversion in case of obstacle	70	
31	CLOSING TORQ 2	10	100	Closing torque Motor 2: By increasing the torque, more strenght will be required to execute the inversion in case of obstacle	70	
32	ENCODER	On		ON = Encoder enabled OFF = Encoder disabled - shows working times learnt	Off	
32	ENCODER	Potentiometer		Enables the reading of the potentiometer with LE card	Off	
51	I.PAR.M1	-----		Reports the current position of the potentiometer on the leaf of Motor 1. This parameter is useful for seeing if the potentiometer is read correctly		
52	I.AP.M1	From the value learned to ± 100 pulses		Reports the impulses stored by the control unit when the leaf of Motor 1 is fully open		
53	I.CH.M1	From the value learned to ± 100 pulses		Reports the impulses stored by the control unit when the leaf of Motor 1 is fully close		
54	I.PAR.M2	-----		Reports the current position of the potentiometer on the leaf of Motor 2. This parameter is useful for seeing if the potentiometer is read correctly		
55	I.AP.M2	From the value learned to ± 100 pulses		Reports the impulses stored by the control unit when the leaf of Motor 2 is fully open		
56	I.CH.M2	From the value learned to ± 100 pulses		Reports the impulses stored by the control unit when the leaf of Motor 2 is fully close		

SP MENU		SET		DESCRIPTION	DEFAULT	NOTE
32	ENCODER	<i>Off</i>		ON = Encoder enabled OFF = Encoder disabled - shows working times learnt	<i>Off</i>	
33	OPENING SENSITIVITY MOTOR 1	<i>10% (Fast intervention)</i>		Adjusts the Encoder or Potentiometer intervention time on Motor 1 in opening	<i>Off</i>	
		<i>99% (Slow intervention)</i>				
34	CLOSING SENSITIVITY MOTOR 1	<i>10% (Fast intervention)</i>		Adjusts the Encoder or Potentiometer intervention time on Motor 1 in closing	<i>Off</i>	
		<i>99% (Slow intervention)</i>				
35	OPENING SENSITIVITY MOTOR 2	<i>10% (Fast intervention)</i>		Adjusts the Encoder or Potentiometer intervention time on Motor 2 in opening	<i>Off</i>	
		<i>99% (Slow intervention)</i>				
36	CLOSING SENSITIVITY MOTOR 2	<i>10% (Fast intervention)</i>		Adjusts the Encoder or Potentiometer intervention time on Motor 2 in closing	<i>Off</i>	
		<i>99% (Slow intervention)</i>				
46	CLOSING INVERSION	<i>Total</i>		In case of obstacle or edge it totally reverses the movement during the closing. If active, the automatic reclosing will be attempted 5 times	<i>Total</i>	
		<i>Partial</i>		It partially reverses the direction (of about 30 cm) in case of obstacle or edge or potentiometer, then it stops		
For menu from 51 to 56 see menu 32-Encoder = Potentiometer						
59	OPENING SLOWDOWN 1	<i>Off (*)</i>	<i>100%</i>	OFF = Disabled 100% = the slowdown will Start at middle of the total stroke	<i>20</i>	
60	CLOSING SLOWDOWN 1	<i>Off (*)</i>	<i>100%</i>	OFF = Disabled 100% = the slowdown will Start at middle of the total stroke	<i>20</i>	
61	OPENING SLOWDOWN 2	<i>Off (*)</i>	<i>100%</i>	OFF = Disabled 100% = the slowdown will Start at middle of the total stroke	<i>20</i>	
62	CLOSING SLOWDOWN 2	<i>Off (*)</i>	<i>100%</i>	OFF = Disabled 100% = the slowdown will Start at middle of the total stroke	<i>20</i>	
63	DECELERATION	<i>0 %</i>		Adjust the passage between normal speed and slowdown speed	<i>5%</i>	
64	ACCELERATION	<i>0 %</i>		Acceleration ramp Adjusts the motor start	<i>100%</i>	
70	OPENING POSITION RECOVERY	<i>0</i>	<i>15 seconds</i>	Retrieves the inertia of the motor in opening after Stop or reversing	<i>1s</i>	
71	CLOSING POSITION RECOVERY	<i>0</i>	<i>15 seconds</i>	Retrieves the inertia of the motor in closing after Stop or reversing	<i>1s</i>	
72	OPENING TOLERANCE MOTOR 1	<i>10% = 20 pulses</i>	<i>99% = 500 pulses</i>	Adjust the tolerance between stop and obstacle on Motor 1 in opening	<i>16% = 80 pulses</i>	
73	CLOSING TOLERANCE MOTOR 1	<i>10% = 20 pulses</i>	<i>99% = 500 pulses</i>	Adjust the tolerance between stop and obstacle on Motor 1 in closing	<i>16% = 80 pulses</i>	
74	OPENING TOLERANCE MOTOR 2	<i>10% = 20 pulses</i>	<i>99% = 500 pulses</i>	Adjust the tolerance between stop and obstacle on Motor 2 in opening	<i>16% = 80 pulses</i>	
75	CLOSING TOLERANCE MOTOR 2	<i>10% = 20 pulses</i>	<i>99% = 500 pulses</i>	Adjust the tolerance between stop and obstacle on Motor 2 in closing	<i>16% = 80 pulses</i>	
76	PUSHING STROKE	<i>Off - 3 seconds</i>		Before opening, the motor starts in closing for the setup time, in order to simplify the lock release	<i>Off</i>	
77	LOCK TIME	<i>Off - 5 seconds</i>		Sets the lock release time from 0 to 5 s	<i>1</i>	
78	LOCK	<i>Only opening</i>		Active only before opening	<i>Only opening</i>	
		<i>Only closing</i>		Active only before cloning		
		<i>Opening and closing</i>		Active before opening and closing		

SP MENU		SET	DESCRIPTION	DEFAULT	NOTE
79	ANTI INTRUSION	Only opening	If you force the gate manually, the control unit starts the motor and restores the state of the gate before forcing it (function available only with limit switch)	Off	
		Only closing			
		Opening and closing			
		Off			
80	PUSHOVER	Off	Allows the leaf to make an extra move at maximum torque to ensure the tightening	Off	
		Opening and closing			
		Only closing			
		Only opening			
81	PERIODICAL PUSHOVER	Off 8	Allows the repetition of the pushover function at a distance of time adjustable from 0 to 8 hours at hourly intervals	Off	
82	MOTOR RELEASE	Opening 1 Off - 3 s	If different from Off, the motor slightly reverse its direction at the end of the cycle Note: on swing operators, the release time of the Motor 2 in closing must not be longer than that of the Motor 1	Off	
		Closing 1 Off - 3 s			
		Opening 2 Off - 3 s			
		Closing 2 Off - 3 s			
		End			
83	EXTRA TIME	Opening 1 Off - 10 s	It adds an extra time to the movement of the motors on direction set	Off	
		Closing 1 Off - 10 s			
		Opening 2 Off - 10 s			
		Closing 2 Off - 10 s			
		End			
84	BRAKE	Off 100%	Adjusts the braking on the limit switches	0	
85	PRE-FLASHING	Only closing	Pre-flashing only active before closing	Off	
		0.0 5.0 s	Pre-flashing		
86	FLASHING LIGHT	Normal	Normal	Normal	
		Light	Control lamp		
		Always	Always ON		
		Buzzer	Buzzer		
87	FLASHING LIGHT AND TIMER	Off	The flashing light stays OFF with the active timer and open gate	Off	
		On	The flashing light stays ON with active timer and open gate		
88	COURTESY LIGHT (Only with SEM 2 management board)	Off	Disabled	In Cycle	
		1 240	Courtesy light setting from 1 second to 4 minutes		
		In cycle	Courtesy light in cycle		
89	TRAFFIC LIGHT RESERVATION (Only with SEM 2 management board)	Off On	If ON, the partial input will be activated to work on the auxiliary board "SEM2" (traffic-light management board)	Off	
90	PARTIAL OPENING	20 100	Setting from 20 to 100	100	
91	PARTIAL PAUSE	= Start	Pause in partial opening same as in total opening	= Start	
		Off	Disabled		
		1 240	Setting from 1second to 4 minutes		
92	TIMER	Off	Turn the selected input into an input to connect an external clock to	Off	
		On photo2			
		On partial entry			

SP MENU		SET	DESCRIPTION	DEFAULT	NOTE
94	24V AUX (Max. 500 mA)	<i>Always</i>	AUX output always Power supplied	<i>Always</i>	
		<i>In cycle</i>	AUX output active only during cycle		
		<i>Opening</i>	AUX output power supplied only in opening		
		<i>Closing</i>	AUX output power supplied only in closing		
		<i>In pause</i>	AUX out put power supplied only in pause		
		<i>Phototest</i>	Security test		
		<i>In cycle and phototest</i>	During cycle only and with Fototest function enabled		
		<i>Positive brake management</i>	Positive Electric-brake (24V in ON with stationary gate)		
		<i>Negative brake management</i>	Negative Electric-brake (24V in On with gate in cycle and 1 sec. before the Start)		
		<i>Negative brake and Photocell management</i>	Negative electric-brake not active on intervention of the photocell		
		<i>Open gate warning Light</i>	1 flash per second in opening 2 flashes per second in closing Steady lit in Stop or Open		
<i>Start 3 s</i>	If active, the 24VAUX output is activated for 3 seconds at every Start input, every photocells or security edge intervention				
95	PHOTOTEST	<i>Photo 1</i>	Self-test active only on photocell 1	<i>Photo 1 and Photo 2</i>	
		<i>Photo 2</i>	Self-test active only on photocell 2		
		<i>Photo 1 and Photo 2</i>	Self-test active on photocells 1 and 2		
97	PHOTOCELL 1 SHADOW LOOP 1	<i>Closing</i>	If the photocell is occupied during closing, it reverses the movement; If the photocell is occupied during the pause, it prevents the reclosing	<i>Closing</i>	
		<i>Opening and closing</i>	If occupied, the photocell blocks the movement as long as it is busy; when released, the opening movement continues		
		<i>Stop</i>	If the photocell is occupied before the Start input, the Start will be ignored. If the photocell is occupied after the Start input, the photocell will be ignored. If the photocell is occupied during closing, the gate will reopen		
		<i>Stop and close</i>	If the photocell is occupied during closing, it stops the movement; when released, the closing movement continues		
		<i>Close</i>	The photocell stops the gate until it is occupied in both opening and closing; when released, the photocell gives a closing command (the gate closes one second after the photocell release)		
		<i>Pause reload</i>	If the photocell is occupied during pause, it recharges the pause time set. If the photocell is occupied during closing, it reverses the movement		
		<i>Shadow loop</i>	Until occupied, with open gate, the shadow loop prevents the reclosing. Shadow loop is switched off during closing		
		<i>Delete pause time</i>	If the photocell is occupied during opening, pause or closing, the gate reopens completely and closes without observing the pause time set		
		<i>Shadow loop RP (pause reloading)</i>	Until occupied, with open gate, the shadow loop prevents the reclosing; when released, the gate repeats the pause time set, then it closes. Shadow loop is switched off during closing		

SP MENU		SET	DESCRIPTION	DEFAULT	NOTE
98	PHOTOCELL 2 SHADOW-LOOP2	<i>Closing</i>	If the photocell is occupied, it reverses the movement in closing; during the pause, it prevents the reclosing	<i>Opening and closing</i>	
		<i>Opening and closing</i>	If active the photocell blocks the movement as long as it is busy; when released, the opening movement continues		
		<i>Stop</i>	If the photocell is activated before the Start input, the Start will be ignored. If it is activated after the Start input, the photocell will be ignored. If it is activated during closing, the gate will reopen		
		<i>Stop and close</i>	In closing, the photocell stops the movement until it is occupied; when released the closing movement continues		
		<i>Close</i>	The photocell stops the gate until it is occupied in both opening and closing; when released, it gives a closing command (it closes one second after its release)		
		<i>Pause reload</i>	If activated, the photocell recharges the time of pause during pause. In closing it reverses the movement		
		<i>Shadow loop</i>	Until occupied, with open gate, it prevents reclosing. It is switched off during closing		
		<i>Delete pause time</i>	If the photocell is activated during opening, pause or closing, the gate reopens completely and closes without observing the pause time		
		<i>Shadow loop RP (pause reloading)</i>	If the shadow loop is temporarily released, the pause time is reloaded before closing		
		<i>Stop and open</i>	If the photocell is activated during opening, the gate stops and will continue in opening only when the photocell is released. It is ignored during closing		
100	SECURITY EDGE 1	<i>Normal</i>	Normal N.C. contact	<i>Normal</i>	
		<i>8K2</i>	Active edge protected by a 8K2 resistor		
		<i>8K2 Double</i>	Allows to connect two 8K2 protected edges		
		<i>Photo 1 10K</i>	Security edge works as a photocell protected by a 10K resistor		
		<i>Photo 1 10K Double</i>	It is possible to connect two photocells protected by a 10K resistor		
102	SECURITY EDGE 1 DIRECTION	<i>Opening and closing</i>	Active in opening and closing	<i>Opening and Closing</i>	
		<i>Only opening</i>	Active only in opening		
		<i>Only closing</i>	Active only in closing		
104	SELECT LIMIT SWITCH	<i>Automatic</i>	Limit switch in automatic recognition	<i>Auto-matic</i>	
		<i>Only opening</i>	Active limit-switch in opening only		
		<i>Only closing</i>	Active limit-switch in closing only		
106	DIAGNOSTICS	1 10	Shows last event (See alarms table)		
107	MAINTENANCE CYCLES	100 240000	Setting from 100 to 240000	100000	
108	PERFORMED CYCLES	0 240000	Reports the executed cycles. Keep pressed OK to reset the cycles	0	
112	PASSWORD	Note: "0000" setting is not allowed	Allows the entering of a password blocking the control unit parameters modification	----	

SP MENU		SET	DESCRIPTION	DEFAULT	NOTE
113	EMERGENCY	<i>Off</i>	Disabled	<i>Off</i>	
		<i>Emergency</i>	Without main power but batteries connected, the gate will open fully and will remain opened. The gate recloses when the power is back		
		<i>Last opening</i>	Without main power, if batteries are lower than 22V the gate opens and stay opened. The gate recloses when the power is back		
		<i>Last closing</i>	Without main power, if batteries are lower than 22V the gate closes and stay closed until the power is back		
117	ALWAYS CLOSE	<i>Off</i> 240 seconds	In the event of a power failure, if the door has been manually opened, it closes only after the set time has elapsed (from 0 to 240 seconds), as soon as the power is restored	<i>Off</i>	
118	LATCH	<i>Off</i>	Disabled	<i>Off</i>	
		<i>Opening</i>	Uses the "Partial Opening" N.O. input (the "Partial Opening" is so disabled). The gate opens and stay open till a new Start input		
		<i>Closing</i>	Uses the "Partial Opening" N.O. input (the "Partial Opening" is so disabled).The gate closes and stay closed till a new Start input		
LATCH FUNCTION NOTES: - To deactivate the Latch function, press the Latch command again or the Stop command or remove the power supply; - The Latch function can also be activated by remote control or by SEACLOUD; if the Latch function is active, pedestrian opening will still be possible both from the remote control and from SEACLOUD					
119	DISPLAY WRITING SPEED	<i>From 30% to 100%</i>	See Note 2 below	<i>80%</i>	
120	BASIC MENU	Press OK to exit the special menu. The special menu switches off automatically after 20 minutes			

Note 1: After initialization the parameters "motor type" and "limit switch type" remain on the value chosen in the setup program

Note 2: Display writing speed set on 30% keeps writing slow; Display writing speed set on 100% keeps writing fast.

Please note that speed does not change on JOLLY 3 display

ALARMS

The control unit advise about faults by a message on the display. The table below shows what faults are advised and what to do in the event of a malfunction. However, it is possible to read the last 10 fault warnings by accessing the **106-DIAGNOSTIC** menu

Note 1: If "**MAXIMUM CYCLES REACHED**" is displayed, the maintenance or the reset of the performed cycles number is necessary (see note (*) below)

Note 2: To exit the alarms display press OK

If the warning signal does not disappear, carry out all the checks required for that error and/or disconnect the device that generates the error to check whether the signal disappears

It is also possible to visualize the warning signals through the flashing light or the pilot light, simply by observing the number of flashes emitted and checking the correspondence in the flashing table below. When an event occurs, the warning flashes are issued at each Start command;

Note 3: When there are no events, the normal operation (with **86-FLASHING LIGHT** set on "**NORMAL**") is: 1 flash per second in opening - 2 flashes per second in closing - steady during pause

WARNING	DESCRIPTION	SOLUTION
FAULT MOTOR	Motor power supply failure	Check that there are no short circuits on the motor or on the control unit
FAULT 24	24V power supply failure	Check that there are no short circuits on wirings or on the control unit or that there is no overload
FAULT 24V AUX CHECK CHARGE OUTPUT 10 CONNECT ACCESSORIES OUTPUT 12	AUX output failure	Check that there are no short circuits on wirings or on the control unit or that there is no overload. The 24VAux is a settable output with maximum load of 600mA; if you do not need the settable output, use the 24V on terminal 12 (+) and use the negative on output 11 (COM) (NOT on output 13!)
FAULT SELF-TEST	Photocells self-test failure	Check the photocells operation and/or wirings on control unit
FAULT LIMIT SWITCH	Limit switch activation fault	Check the operation of both limit switches and/or the correspondence between the motor movement direction and the engaged limit switch
FAULT FLASHING LIGHT	Flashing Light fault	Check the wirings and/or the condition of the lamp
FAULT OVERCURRENT COLLISION	Failure overcurrent collision	Check the presence of obstacles or points of friction on the gate <i>NOTE: the warning signal can be reset by pressing OK</i>

NUMBER OF FLASHES	ALARM TYPE
9	Motor failure
2	Photocell in closing
3	Photocell in opening
6	Opening collision
4	Safety edge
5	Stop
7	Maximum cycles reached
6	Closing collision
4 Faster	Limit switch error

***** Periodically, based on the number of maneuvers performed over time and on the type of operator, if a change in friction, malfunctioning or non-compliance with the previously set times are noticed, ***it would be advisable to reprogram the learning times on the control unit***. The warning signal "MAXIMUM CYCLES REACHED" and the 7 flashes shown in the table aside refer to the achievement of the maximum cycles established before maintenance; therefore it is advisable to carry out maintenance and reset the number of cycles on the control unit

TROUBLESHOOTING

Advices		
Make sure all Safeties are turned ON		
Problem Found	Possible Cause	Solutions
Operator doesn't respond to any START impulse	<ul style="list-style-type: none"> a) Check the connected N.C. contacts b) Burnt fuse 	<ul style="list-style-type: none"> a) Check the connections or the jumpers on the connections of the safety edge or of the stop and of the photocell if connected b) Replace the burnt fuse on the control unit
Operator does not run and diagnostic display not on.	<ul style="list-style-type: none"> a) No power to control board b) Open fuse c) Defective control board d) If on battery power only, low or dead batteries 	<ul style="list-style-type: none"> a) Check AC power b) Check fuses c) Replace defective control board d) Charge batteries by AC or solar power or replace batteries
Operator does not respond to a wired control/command (example: Open, Close, etc.)	<ul style="list-style-type: none"> a) Check Open and Close command input b) Stop button is active c) Reset button is stuck d) Entrapment Protection Device active e) If on battery power only, low or dead batteries 	<ul style="list-style-type: none"> a) Check all Open and Close inputs for a stuck on input b) Check Stop button is not stuck on c) Check Reset button d) Check all Entrapment Protection Device inputs for a stuck on sensor e) Charge batteries by AC or solar power or replace batteries
Operator does not respond to a transmitter	<ul style="list-style-type: none"> a) Stop button is active b) Reset button is stuck c) Poor radio reception 	<ul style="list-style-type: none"> a) Check Stop button is not stuck on b) Check Reset button c) Check if similar wired control operates correctly. Check antenna wire
Motor turn only one way	<ul style="list-style-type: none"> a) Try to invert the motor phase and watch if the motor change or not the direction 	<ul style="list-style-type: none"> a) If the motor is blocked change the cable if the motor go only in one direction the motor relay direction is damaged
Gate doesn't move while the motor is running	<ul style="list-style-type: none"> a) The motor is in the released position b) There is an obstacle 	<ul style="list-style-type: none"> a) Re-lock the motor b) Remove obstacle
Gate doesn't reach the complete Open / Closed position	<ul style="list-style-type: none"> a) Wrong setting of the limit switches b) Error on programming c) Gate is stopped by an obstacle d) Torque too low e) Gate is too heavy for automatic slow-down 	<ul style="list-style-type: none"> a) Set limit switches b) Repeat programming c) Remove obstacle d) Increase torque parameter e) Set the slow-down on OFF
Gate opens but doesn't close	<ul style="list-style-type: none"> a) The contacts of the photocells are connected and open b) The stop contact is connected and open c) The edge contact is open d) Ammeter alarm 	<ul style="list-style-type: none"> a) b) c) Check the jumpers or the connected devices and the signals indicated on the warning lamp d) Check if the ammeter alarm has intervened and eventually increase the torque parameter
Gate doesn't close automatically	<ul style="list-style-type: none"> a) Pause time set too high b) Control unit in semi-automatic logic 	<ul style="list-style-type: none"> a) Adjust pause time b) Set the pause parameter on a different value from the OFF
Gate moves, but cannot set correct limits	<ul style="list-style-type: none"> a) Gate does not move to a limit position b) Gate is too difficult to move 	<ul style="list-style-type: none"> a) Use manual disconnect, manually move gate, and ensure gate moves easily limit to limit. Repair gate as needed b) Gate must move easily and freely through its entire range, limit to limit. Repair gate as needed
Gate does not fully open or fully close when setting limits	<ul style="list-style-type: none"> a) Gate does not move to a limit position b) Gate is too difficult to move 	<ul style="list-style-type: none"> a) Use manual disconnect, manually move gate, and ensure gate moves easily limit to limit. Repair gate as needed b) Gate must move easily and freely through its entire range, limit to limit Repair gate as needed
Gate stops during travel and reverses immediately	<ul style="list-style-type: none"> a) Control Open/Close becoming active b) The obstacle sensitivity is too low c) Low battery voltage 	<ul style="list-style-type: none"> a) Check all Open and Close inputs for an active input b) Check the obstacle sensitivity value and try to increase this parameter c) Battery voltage must be 23.0 Vdc or higher. Charge batteries by AC or solar power or replace batteries

...NEXT

Advices		
Make sure all Safeties are turned ON		
Problem Found	Possible Cause	Solutions
Gate opens, but will not close with transmitter or pause time different from OFF	<ul style="list-style-type: none"> a) Open control active b) Pause not set c) Close Entrapment Protecting Device active d) Photocells contact is open e) Fire-switch input active 	<ul style="list-style-type: none"> a) Check all Open inputs for an active input b) Check pause settings c) Check all Entrapment Protection Device inputs for an active sensor d) Check photocells contact e) Check fire-switch input
Gate doesn't respect slow down points	<ul style="list-style-type: none"> a) ENCODER is not working properly if It's activated b) Mechanical clutch loose c) Slow down space is too wide d) Potentiometer is not working properly if It's activated e) The recovery position parameters are too high or too low 	<ul style="list-style-type: none"> a) Check menu for encoder parameters "Encoder Par" shall be from a low value +/- 10 (gate completely closed) to "Encoder tot" (gate completely opened). If the movement of Ipar is not linear in the range (+/-10 - Encoder tot) probably the Encoder is defective b) Tight mechanical clutch c) Reduce slow down space d) Check menu for potentiometer parameters "IPar" shall be from "I. CH." (gate completely closed) to "I.AP." (gate completely opened). If the movement of Ipar is not linear in the range (I.AP. - I.CH.) probably the potentiometer is defective e) Reduce or increase the recovery position parameters
Gate opens suddenly without start command	<ul style="list-style-type: none"> a) Frequency or other noise from main line b) Short circuit on the start contact 	<ul style="list-style-type: none"> a) Wiring AC shall be separate from DC wire and pass through separate conduits. If there is a frequency noise it is possible to change frequency to another MHz like 868 for example or FM b) Check all start contacts
Gate doesn't close in automatic logic during pause even if a loop/photo is set as start	<ul style="list-style-type: none"> a) START IN PAUSE is not in ON b) The photo/loop input is not set as "Delay pause time" 	<ul style="list-style-type: none"> a) Put in ON the menu of START IN PAUSE b) Set in the photo/loop menu "Delay pause time"
Gate doesn't have power to close or reach limit switch	<ul style="list-style-type: none"> a) Slow down not possible for that site due to heavy gate or inclination or not new installation 	<ul style="list-style-type: none"> a) Put Slow Down in OFF
Obstruction in gates path does not cause gate to stop and reverse	<ul style="list-style-type: none"> a) Force adjustment needed 	<ul style="list-style-type: none"> a) Refer to the Adjustment section to conduct the obstruction test and perform the proper force adjustment that is needed (sensitivity - torque)
Photoelectric sensor does not stop or reverse gate	<ul style="list-style-type: none"> a) Incorrect photoelectric sensor wiring b) Defective photoelectric sensor c) Photoelectric sensors installed too far apart 	<ul style="list-style-type: none"> a) Check photoelectric sensor wiring. Retest that obstructing photoelectric sensor causes moving gate to stop, and may reverse direction b) Replace defective photoelectric sensor. Retest that obstructing photoelectric sensor causes moving gate to stop, and may reverse direction c) Move the photoelectric sensors closer together or use edge sensors instead
Edge Sensor does not stop or reverse gate	<ul style="list-style-type: none"> a) Incorrect edge sensor wiring b) Defective edge sensor 	<ul style="list-style-type: none"> a) Check edge sensor wiring. Retest that activating edge sensor causes moving gate to stop and reverse direction b) Replace defective edge sensor. Retest that activating edge sensor causes moving gate to stop and reverse direction
Alarm sounds for 5 minutes or alarm sounds with a command	<ul style="list-style-type: none"> a) Double entrapment occurred (two obstructions within a single activation) 	<ul style="list-style-type: none"> a) Check for cause of entrapment (obstruction) detection and correct. Press the reset button to shut off alarm and reset the operator.
Shadow loop does not keep gate at the open limit	<ul style="list-style-type: none"> a) Vehicle detector setup incorrectly b) Defective vehicle loop detector c) Wrong settings 	<ul style="list-style-type: none"> a) Review Shadow loop detector settings. Adjust settings as needed b) Replace defective Shadow loop detector c) Check the photo2 menu is set on shadow loop
Accessories connected to the accessory power not working correctly, turning off or resetting	<ul style="list-style-type: none"> a) Accessory power protector active b) Defective control board 	<ul style="list-style-type: none"> a) Disconnect all accessory powered devices and measure accessory power voltage (should be 23-30 Vdc). If voltage is correct, connect accessories one at a time, measuring accessory voltage after every new connection b) Replace defective control board

Advices		
Make sure all Safeties are turned ON		
Problem Found	Possible Cause	Solutions
FAILURE 24VAUX	a) Overload or short-circuit on the output N°10 b) Burnt fuse	a) Check a short circuit on the cable b) Change fuse
Control board powers up, but motor does not run	a) Stop button active or jumper not in place for stop circuit b) Open or Close Input active c) Entrapment Protection Device active d) Defective control board	a) Check Stop button is not "stuck on", or verify that the stop button is a normally closed circuit, or put a jumper on the stop circuit b) Check all Open and Close Inputs for a "stuck on" Input c) Check all Entrapment Protection Device inputs for a "stuck on" sensor d) Replace defective control board
Solar operator not getting enough cycles per day	a) Insufficient panel wattage b) Excessive accessory power draw c) Old batteries d) Solar panels are not getting enough sunlight	a) Add more solar panels b) Reduce the accessory power by using low power accessories or set the 24Vaux only in cycle c) Replace batteries d) Relocate the solar panels away from obstructions (trees, buildings, etc.)
Solar operator insufficient stand-by time	a) Insufficient panel wattage b) Excessive accessory power draw c) Battery capacity too low	a) Add more solar panels b) Reduce the accessory power draw by using low power accessories c) Use batteries with higher amp hour (Ah) rating

TO THE ATTENTION OF BOTH INSTALLER AND END USER

MAINTENANCE

Periodically, based on the number of maneuvers performed over time and based on the type of operator, if a change in friction, malfunctioning or non-compliance with the previously set times are noticed, **it would be advisable to reprogram the learning times on the control unit**

Periodically clean the optical systems of the photocells

REPLACEMENTS

Any request for spare parts must be sent to: **SEA S.p.A. - 64020 - Teramo - ITALY - www.seateam.com**

SAFETY AND ENVIRONMENTAL COMPATIBILITY

Disposal of packaging materials and/or circuits should take place in an approved disposal facility



REGULAR PRODUCT DISPOSAL (electric and electronic waste)

(It's applicable in EU countries and in those ones provided with a differential waste collection)

This brand on the product or on documentation indicates that the product must not be disposed off together with other domestic waste at the end of its life cycle. In order to avoid any possible environmental or health damage caused by irregular waste disposal, we recommend to separate this product from other types of waste and to recycle it in a responsible way in order to provide the sustainable re-use of material resources. Domestic users are invited to contact the retailer where the product has been purchased or the local office to get all the information related to differential waste collection and recycling of this kind of product

IMMAGAZZINAMENTO

WAREHOUSING TEMPERATURES

T _{min}	T _{Max}	Dampness _{min}	Dampness _{Max}
- 20°C	+ 65°C	5% not condensing	90% not condensing

Materials handling must be made with appropriate vehicles

WARRANTY LIMITS - see the sales conditions

SEA S.p.A. reserves the right to make any required modification or change to the products and/or to this manual without any advanced notice obligation

TERMS OF SALES

EFFICACY OF THE FOLLOWING TERMS OF SALE: the following general terms of sale shall be applied to all orders sent to SEA S.p.A. All sales made by SEA to all costumers are made under the prescription of this terms of sales which are integral part of sale contract and cancel and substitute all apposed clauses or specific negotiations present in order document received from the buyer.

GENERAL NOTICE The systems must be assembled exclusively with SEA components, unless specific agreements apply. Non-compliance with the applicable safety standards (European Standards EM12453 – EM 12445) and with good installation practice releases SEA from any responsibilities. SEA shall not be held responsible for any failure to execute a correct and safe installation under the above mentioned standards.

1) PROPOSED ORDER The proposed order shall be accepted only prior SEA approval of it. By signing the proposed order, the Buyer shall be bound to enter a purchase agreement, according to the specifications stated in the proposed order.

On the other hand, failure to notify the Buyer of said approval must not be construed as automatic acceptance on the part of SEA.

2) PERIOD OF THE OFFER The offer proposed by SEA or by its branch sales department shall be valid for 30 solar days, unless otherwise notified.

3) PRICING The prices in the proposed order are quoted from the Price List which is valid on the date the order was issued. The discounts granted by the branch sales department of SEA shall apply only prior to acceptance on the part of SEA. The prices are for merchandise delivered ex-works from the SEA establishment in Teramo, not including VAT and special packaging. SEA reserves the right to change at any time this price list, providing timely notice to the sales network. The special sales conditions with extra discount on quantity basis (Qx, Qx1, Qx2, Qx3 formula) is reserved to official distributors under SEA management written agreement.

4) PAYMENTS The accepted forms of payment are each time notified or approved by SEA. The interest rate on delay in payment shall be 1.5% every month but anyway shall not be higher than the max. interest rate legally permitted.

5) DELIVERY Delivery shall take place, approximately and not peremptorily, within 30 working days from the date of receipt of the order, unless otherwise notified. Transport of the goods sold shall be at Buyer's cost and risk. SEA shall not bear the costs of delivery giving the goods to the carrier, as chosen either by SEA or by the Buyer. Any loss and/or damage of the goods during transport, are at Buyer's cost.

6) COMPLAINTS Any complaints and/or claims shall be sent to SEA within 8 solar days from receipt of the goods, proved by adequate supporting documents as to their truthfulness.

7) SUPPLY The concerning order will be accepted by SEA without any engagement and subordinately to the possibility to get it's supplies of raw material which is necessary for the production; Eventual completely or partially unsuccessful executions cannot be reason for complains or reservations for damage. SEA supply is strictly limited to the goods of its manufacturing, not including assembly, installation and testing. SEA, therefore, disclaims any responsibility for damage deriving, also to third parties, from non-compliance of safety standards and good practice during installation and use of the purchased products.

8) WARRANTY The standard warranty period is 12 months. This warranty time can be extended by means of expedition of the warranty coupon as follows:

SILVER: The mechanical components of the operators belonging to this line are guaranteed for 24 months from the date of manufacturing written on the operator.

GOLD: The mechanical components of the operators belonging to this line are guaranteed for 36 months from the date of manufacturing written on the operator.

PLATINUM: The mechanical components of the operators belonging to this line are guaranteed for 36 months from the date of manufacturing written on the operator. The base warranty (36 months) will be extended for further 24 months (up to a total of 60 months) when it is acquired the certificate of warranty which will be filled in and sent to SEA S.p.A. The electronic devices and the systems of command are guaranteed for 24 months from the date of manufacturing. In case of defective product, SEA undertakes to replace free of charge or to repair the goods provided that they are returned to SEA repair centre. The definition of warranty status is by unquestionable assessment of SEA. The replaced parts shall remain propriety of SEA. Binding upon the parties, the material held in warranty by the Buyer, must be sent back to SEA repair centre with fees prepaid, and shall be dispatched by SEA with carriage forward. The warranty shall not cover any required labour activities.

The recognized defects, whatever their nature, shall not produce any responsibility and/or damage claim on the part of the Buyer against SEA. The guarantee is in no case recognized if changes are made to the goods, or in the case of improper use, or in the case of tampering or improper assembly, or if the label affixed by the manufacturer has been removed including the SEA registered trademark No. 804888. Furthermore, the warranty shall not apply if SEA products are partly or completely coupled with non-original mechanical and/or electronic components, and in particular, without a specific relevant authorization, and if the Buyer is not making regular payments. The warranty shall not cover damage caused by transport, expendable material, faults due to non-conformity with performance specifications of the products shown in the price list. No indemnification is granted during repairing and/or replacing of the goods in warranty. SEA disclaims any responsibility for damage to objects and persons deriving from non-compliance with safety standards, installation instructions or use of sold goods. The repair of products under warranty and out of warranty is subject to compliance with the procedures notified by SEA.

9) RESERVED DOMAIN A clause of reserved domain applies to the sold goods; SEA shall decide autonomously whether to make use of it or not, whereby the Buyer purchases propriety of the goods only after full payment of the latter.

10) COMPETENT COURT OF LAW In case of disputes arising from the application of the agreement, the competent court of law is the tribunal of Teramo. SEA reserves the faculty to make technical changes to improve its own products, which are not in this price list at any moment and without notice. SEA declines any responsibility due to possible mistakes contained inside the present price list caused by printing and/or copying. The present price list cancels and substitutes the previous ones. The Buyer, according to the law No. 196/2003 (privacy code) consents to put his personal data, deriving from the present contract, in SEA archives and electronic files, and he also gives his consent to their treatment for commercial and administrative purposes.

Industrial ownership rights: once the Buyer has recognized that SEA has the exclusive legal ownership of the registered SEA brand num.804888 affixed on product labels and / or on manuals and / or on any other documentation, he will commit himself to use it in a way which does not reduce the value of these rights, he won't also remove, replace or modify brands or any other particularity from the products. Any kind of replication or use of SEA brand is forbidden as well as of any particularity on the products, unless preventive and expressed authorization by SEA.

In accomplishment with art. 1341 of the Italian Civil Law it will be approved expressly clauses under numbers:

4) PAYMENTS - 8) GUARANTEE - 10) COMPETENT COURT OF LAW

English GENERAL NOTICE FOR THE INSTALLER AND THE USER

1. Read carefully these **Instructions** before beginning to install the product. Store these instructions for future reference
2. Don't waste product packaging materials and /or circuits.
3. This product was designed and built strictly for the use indicated in this documentation. Any other use, not expressly indicated here, could compromise the good condition/operation of the product and/or be a source of danger. SEA S.p.A. declines all liability caused by improper use or different use in respect to the intended one.
4. The mechanical parts must be comply with Directives: Machine Regulation 2006/42/CE and following adjustments), Low Tension (2006/95/CE), electromgnetic Consistency (2004/108/CE) Installation must be done respecting Directives: EN12453 and En12445.
5. Do not install the equipment in an explosive atmosphere.
6. SEA S.p.A. is not responsible for failure to observe Good Techniques in the construction of the locking elements to motorize, or for any deformation that may occur during use.
7. Before attempting any job on the system, cut out electrical power and disconnect the batteries. Be sure that the earthing system is perfectly constructed, and connect it metal parts of the lock.
8. Use of the indicator-light is recommended for every system, as well as a warning sign well-fixed to the frame structure.
9. SEA S.p.A. declines all liability as concerns the automated system's security and efficiency, if components used, are not produced by SEAS.p.A..
10. For maintenance, strictly use original parts by SEA.
11. Do not modify in any way the components of the automated system.
12. The installer shall supply all information concerning system's manual functioning in case of emergency, and shall hand over to the user the warnings handbook supplied with the product.
13. Do not allow children or adults to stay near the product while it is operating. The application cannot be used by children, by people with reduced physical, mental or sensorial capacity, or by people without experience or necessary training. Keep remote controls or other pulse generators away from children, to prevent involuntary activation of the system.
14. Transit through the leaves is allowed only when the gate is fully open.
15. The User must not attempt to repair or to take direct action on the system and must solely contact qualified SEA personnel or SEA service centers. User can apply only the manual function of emergency.
16. The power cables maximum length between the central engine and motors should not be greater than 10 m. Use cables with 2,5 mm² section. Use double insulation cable (cable sheath) to the immediate vicinity of the terminals, in particular for the 230V cable. Keep an adequate distance (at least 2.5 mm in air), between the conductors in low voltage (230V) and the conductors in low voltage safety (SELV) or use an appropriate sheath that provides extra insulation having a thickness of 1 mm.



Automatic Gate Openers

Questo articolo è stato prodotto seguendo rigide procedure di lavorazione ed è stato testato singolarmente al fine di garantire i più alti livelli qualitativi e la vostra soddisfazione. Vi ringraziamo per aver scelto SEA.

This item has been produced following strict production procedures and has been singularly tested for the highest quality levels and for your complete satisfaction.
Thanks for choosing SEA.

Cet article a été produit suivant des procédures d'usinage strictes et il a singulièrement été testé afin de garantir les plus hauts niveaux de qualité pour votre satisfaction.
Nous vous remercions d'avoir choisi SEA.

Este artículo ha sido producido siguiendo rigidos procedimientos de elaboración y ha sido probando singolarmente a fin de garantizar los mas altos niveles de calidad y vuestra satisfaccion.
Le agradecemos por haber escogito SEA.

Dichiarazione di conformità
Declaration of Conformity

La SEA S.p.A. dichiara sotto la propria responsabilità e, se applicabile, del suo rappresentante autorizzato che il prodotto:

SEA S.p.A. declares under its proper responsibility and, if applicable, under the responsibility of its authorised representative that the product:

Descrizione / Description	Modello / Model	Marca / Trademark
USER 1 24V DG ALL IN (e tutti i suoi derivati / <i>and all its by-products</i>)	23024040/45/48	SEA

è costruito per essere incorporato in una macchina o per essere assemblato con altri macchinari per costruire una macchina ai sensi della Direttiva 2006/42/CE

is built to be integrated into a machine or to be assembled with other machinery to create a machine under the provisions of Directive 2006/42/CE

è conforme ai requisiti essenziali di sicurezza relativi al prodotto entro il campo di applicabilità delle Direttive Comunitarie 2014/35/UE e 2014/30/UE

is conforming to the essential safety requirements related to the product within the field of applicability of the Community Directives 2014/35/UE and 2014/30/UE

COSTRUTTORE o RAPPRESENTANTE AUTORIZZATO:
MANUFACTURER or AUTHORISED REPRESENTATIVE:

SEA S.p.A.

DIREZIONE E STABILIMENTO:

Zona industriale 64020 S.ATTO Teramo - (ITALY)

Tel. +39 0861 588341 r.a. Fax +39 0861 588344

[Http://www.seateam.com](http://www.seateam.com)

Luogo, data di emissione

Place, date of issue

Teramo, 01/04/2019

L'Amministratore
The Administrator
Ennio Di Saverio





Automatic Gate Openers

International registered trademark n. 804888

SEA S.p.A.

Zona industriale 64020 S.ATTO Teramo - (ITALY)

Tel. +39 0861 588341 r.a. Fax +39 0861 588344

www.seateam.com

seacom@seateam.com