



TABLE OF CONTENTS

Important safety requirements.....	1
Responsibilities of the installer/technician.....	2-3
Important safety requirements by UL Standards.....	4-5
UL gate classification - Electrical Connection - Wire Gauge.....	6
General specifications.....	7
Concrete pad location.....	8
Installation specifications.....	9
Rail location requirements.....	10
Case mounting specifications.....	11
Limit block location.....	12
Drive mounting specifications.....	13
Plug connections.....	14-15
Push button controls.....	16
Dip switch configuration.....	17-18
Terminal strip connections.....	19-20
Entrapment and safety protection.....	21
Exploded view.....	22-24
Parts list.....	25-26
End user's responsibilities.....	27
Emergency release procedure.....	28
Gate entrance warning - Placard safety.....	29

**WARNING: DO NOT INSTALL THIS GATE OPERATOR SYSTEM
UNLESS YOU ARE A TRAINED, EXPERIENCED GATE TECHNICIAN**

IMPORTANT SAFETY REQUIREMENTS

- Read, understand & follow the instruction manual
- Never let children operate or play with gate controls. Keep the remote control away from children.
- Always keep people and objects away from the gate. No one should cross the path of the moving gate.
- Test the vehicular gate operator monthly. The gate **MUST** reverse on contact with a rigid object or stop when an object activates the non-contact sensors. After adjusting the limit of travel, retest the vehicular gate operator. Failure to adjust and retest the vehicular gate operator properly can increase the risk of injury or death.
- Use the Emergency release only when power switch or circuit breaker has been turned off. Using the emergency release during a power failure can be a hazard if power is abruptly restored.
- **KEEP GATES PROPERLY MAINTAINED.** Read the owner's manual. Have a qualified service person make repairs to gate hardware.
- The entrance is for vehicles only. Pedestrians must use separate entrance.
- **SAVE THESE INSTRUCTIONS.**

RESPONSIBILITIES OF THE INSTALLER/TECHNICIAN

**** RAMSET GATE OPERATORS SHOULD ONLY BE INSTALLED, MAINTAINED AND SERVICED BY QUALIFIED TECHNICIANS WHO HAVE APPROPRIATE TRAINING WITH GATE OPERATORS****

INSTALLATION:

- READ AND UNDERSTAND THE INSTRUCTION MANUAL BEFORE ATTEMPTING ANY INSTALLATION.
- USE THE PROPER OPERATOR. TAKE THE FOLLOWING INTO CONSIDERATION:
 - CATEGORY (SWING, SLIDE OR OVERHEAD)
 - TYPE (STANDARD, UPHILL, COMPACT , CANTILEVER ...ETC)
 - ALL MEASUREMENTS, SPECIFICATIONS AND CAPABILITIES IN THIS MANUAL ARE FOR STANDARD INSTALLATIONS. ALL OTHER TYPES OF INSTALLATIONS LOWER THE CAPABILITIES OF THE OPERATOR.
 - GATE WEIGHT
 - TRAVEL LENGTH
 - CLASS (SEE PAGE 6)
- DO NOT EXCEED THE EQUIPMENTS SPECIFICATIONS AND CAPABILITIES.

SAFETY:

- SAFETY IS THE PRIMARY CONCERN WHEN INSTALLING A GATE OPERATOR.
- INSURE A SAFE AND PROPER INSTALLATION FOLLOWING ALL BUILDING, FIRE, ELECTRICAL, PROPERTY MAINTENANCE, ASTM F 2200 AND UL 325 SAFETY CODES.
- ONLY USE UL 325 COMPLIANT ACCESSORIES AND EQUIPMENT.
- ALL EXPOSED PINCH POINTS ARE ELIMINATED OR GUARDED.
- ALL EXPOSED ROLLERS ARE GUARDED.
- WHEN SERVICING A GATE OPERATOR ALWAYS PERFORM AN INSPECTION OF THE ENTIRE INSTALLATION AND MAKE ANY AND ALL SUGGESTIONS, TO THE PROPERTY OWNER, TO BRING THEIR SYSTEM INTO COMPLIANCE WITH THE CURRENT UL STANDARD.
- WARNING SIGNS MUST BE PERMANENTLY AFFIXED TO THE GATE PANEL IN A HIGHLY VISIBLE PLACE THAT CAN BE EASILY SEEN FROM BOTH SIDES OF THE GATE.
- A SEPARATE ENTRANCE IS SUPPLIED FOR PEDESTRIANS. THE OPERATOR IS INTENDED FOR INSTALLATION ONLY FOR GATES USED FOR VEHICLES.
- THE GATE MUST BE INSTALLED IN A LOCATION SO THAT ENOUGH CLEARANCE IS SUPPLIED BETWEEN THE GATE AND ADJACENT STRUCTURES WHEN OPENING AND CLOSING TO REDUCE THE RISK OF ENTRAPMENT.

RESPONSIBILITIES OF THE INSTALLER/TECHNICIAN cont.

SAFETY cont.:

- ALL CONTROLS MUST BE LOCATED AT LEAST 6 FEET AWAY FROM ANY PART OF THE GATE OPERATOR OR MOVING GATE AT ALL TIMES.
- INTERIOR CONTROL STATIONS SHOULD BE INSTALLED SO THAT THE USER HAS A DIRECT LINE OF SIGHT TO THE GATE AREA BEING CONTROLLED.
- PHOTOCELLS SHOULD BE INSTALLED WITHIN 5 INCHES FROM THE GATE PANEL AND A MAXIMUM HEIGHT OF 27.5 INCHES.
- A PHOTOCELL IS A SAFETY DEVICE FOR PEDESTRIANS ONLY; VEHICLE DETECTORS SHOULD ALWAYS BE USED FOR DETECTION OF MOTOR VEHICLES.
- NO SAFETY DEVICES SHOULD EVER BE BYPASSED, REMOVED OR OMITTED BY THE INSTALLER/TECHNICIAN. A SIGNED WAIVER DOES NOT NULIFY THE INSTALLER/TECHNICIANS LIABILITY DUE TO THE FACT THAT IT HAS NO SUBSTANCE IN LITIGATION INVOLVING AN INJURED PARTY WHO DID NOT SIGN THE WAIVER.
- IF YOU ARE INSTALLING THE OPERATOR ON A GATE THAT DID NOT HAVE AN OPERATOR ON IT, THE GATE MUST CONFORM TO THE CURRENT ASTM F 2200 STANDARDS.
- IF YOU ARE INSTALLING THE OPERATOR ON A GATE THAT ALREADY HAD AN OPERATOR ON IT, THE TECHNICIAN/INSTALLER SHOULD ADVISE THE CUSTOMER OF THE UPGRADES THAT ARE NEEDED TO BRING THE GATE UP TO THE CURRENT ASTM F 2200 STANDARDS.
- WHEN INSTALLING OR WORKING ON A GATE OPERATOR SYSTEM, ALWAYS MAKE SURE THAT THE AREA AROUND YOU IS SECURE. USE CONES, YELLOW CAUTION TAPE OR WHEN POSSIBLE, BLOCK OFF THE DRIVEWAY FROM TRAFFIC.
- WHEN NECESSARY, INSTALL SURGE/LIGHTNING SUPPRESSION AND GROUND RODS.

IMPORTANT SAFETY REQUIREMENTS BY UL STANDARDS

Prior to installation, the following must be observed: (UL 325.58.8.4)

- a) Install the gate operator only when:
 - 1) The operator is appropriate for the construction of the gate and the usage Class of the gate,
 - 2) All openings of a horizontal slide gate are guarded or screened from the bottom of the gate to a minimum of 6 feet (1.83m) above the ground to prevent a 2 ¼ inch (57.2 mm) diameter sphere from passing through the openings anywhere in the gate, and in that portion of the adjacent fence that the gate covers in the open position,
 - 3) All exposed pinch points are eliminated or guarded, and
 - 4) Guarding is supplied for exposed rollers.
- b) The operator is intended for installation only on gates used for vehicles. Pedestrians must be supplied with a separate access opening. The pedestrian access opening shall be designed to promote pedestrian usage. Locate the gate such that persons will not come in contact with the vehicular gate during the entire path of travel of the vehicular gate.
- c) The gate must be installed in a location so that enough clearance is supplied between the gate and adjacent structures when opening and closing to reduce the risk of entrapment. Swinging gates shall not open into public access areas.
- d) The gate must be properly installed and work freely in both directions prior to the installation of the gate operator. Do not over-tighten the operator clutch or pressure relief valve to compensate for a damaged gate.
- e) For gate operator utilizing Type D protection:
 - 1) The gate operator controls must be placed so that the user has full view of the gate area when the gate is moving,
 - 2) The placard as required by 60.1.6 shall be placed adjacent to the controls,
 - 3) An automatic closing device (such as a timer, loop sensor, or similar device) shall not be employed, and
 - 4) No other activation device shall be connected.
- f) Controls intended for user activation must be located at least six feet (6') away from any moving part of the gate and where the user is prevented from reaching over, under, around or through the gate to operate the controls.
 - ***Exception: Emergency access controls only accessible by authorized personnel (e.g. fire, police, EMS) may be placed at any location in the line-of-sight of the gate.
- g) The Stop and/or Reset button must be located in the line-of-sight of the gate. Activation of the reset control shall not cause the operator to start.
- h) A minimum of two (2) WARNING SIGNS shall be installed, one on each side of the gate where easily visible.

IMPORTANT SAFETY REQUIREMENTS BY UL STANDARDS cont.

- i) For gate operators utilizing a non-contact sensor in accordance with 31.1.1:
 - 1) See instructions on the placement of non-contact sensors for each Type of application,
 - 2) Care shall be exercised to reduce the risk of nuisance tripping, such as when a vehicle, trips the sensor while the gate is still moving, and
 - 3) One or more non-contact sensors shall be located where the risk of entrapment or obstruction exists, such as the perimeter reachable by a moving gate or barrier.
- j) For a gate operator utilizing a contact sensor in accordance with 31.1.1:
 - 1) One or more contact sensors shall be located where the risk of entrapment or obstruction exists, such as at the leading edge, trailing edge, and postmounted both inside and outside of a vehicular horizontal slide gate.
 - 2) One or more contact sensors shall be located at the bottom edge of a vehicular vertical lift gate.
 - 3) One or more contact sensors shall be located at the pinch point of a vehicular vertical pivot gate.
 - 4) A hardwired contact sensor shall be located and its wiring arranged so that the communication between the sensor and the gate operator is not subjected to mechanical damage.
 - 5) A wireless device such as one that transmits radio frequency (RF) signals to the gate operator for entrapment protection functions shall be located where the transmission of the signals are not obstructed or impeded by building structures, natural landscaping or similar obstruction. A wireless device shall function under the intended end-use conditions.
 - 6) One or more contact sensors shall be located on the inside and outside leading edge of a swing gate. Additionally, if the bottom edge of a swing gate is greater than 6 inches (152 mm) above the ground at any point in its arc of travel, one or more contact sensors shall be located on the bottom edge.
 - 7) One or more contact sensors shall be located at the bottom edge of a vertical barrier (arm).

UL GATE CLASSIFICATION

Class I Residential Vehicular Gate Operator (3.19)

A vehicular gate operator (or system) intended for use in garages or parking areas associated with a residence of one-to four single families.

Class II Commercial/General Access Vehicular Gate Operator (3.4)

A vehicular gate operator (or system) intended for use in a commercial location or building such as a multi-family housing unit (five or more single family units), hotel, garages, retail store or other buildings accessible by or servicing the general public.

Class III Industrial/Limited Access Vehicular Gate Operator(3.11)

A vehicular gate operator (or system) intended for use in an industrial location or building such as a factory or loading dock area or other locations not accessible by or intended to service the general public.

Class IV Restricted Access Vehicular Gate Operator (3.20)

A vehicular gate operator (or system) intended for use in a guarded industrial location or building such as an airport security area or other restricted access locations not servicing the general public, in which unauthorized access is prevented via supervision by security personnel.

RECOMMENDED ELECTRICAL CONNECTION

A 3 wire, 120VAC electrical circuit with a 15 amps independent circuit breaker for single operator and a 20 amps for Primary/Secondary. Ideally, the electrical conduits should exit the concrete under the operator. Low voltage control wires must be run in a separate conduit to the operator.

NOTE: ALWAYS CONSULT AND FOLLOW ALL LOCAL BUILDING AND ELECTRICAL CODES PRIOR TO INSTALLATION.

RECOMMENDED WIRE GAUGE

INPUT POWER	MOTOR HP	FLA
115V Single Phase	1	9.4 Amperes
230V Single Phase	1	5 Amperes

MAXIMUM CONDUIT DISTANCE IN FEET USING COPPER WIRE BY WIRE SIZE

Voltage	12ga.	10ga.	8ga.	6ga.
115 VAC	n/a	Up to 150'	150' to 230'	230' - 400'
230 VAC	Up to 350'	600'	850'	1000'

GENERAL SPECIFICATIONS

MODEL	ALL SECURE
Max. Gate Length	No Limit
Max. Applied Force	91 lbs
Cycles	Continuous
Capacitor	Aerovox 65 μ f, 240 V, 50/60 HZ, protected S 1000AFC
Application	Commercial/ Industrial
Finish and Construction	Gold/Zinc plated H.R. Metal
Continuous Duty Motor	1 Hp, 1625 RPM, 115 VAC, 9.4 Amps, 60 Hz or 1 Hp, 1625 RPM, 230 VAC, 4.7 Amps, 60 Hz
Power Failure Release	Hand Operated Release
Overall Dimensions	H 22" - L 14½" - W 15" H 27" - L 16" - W 16½" H 27" - L 16" - W 16½"
Gate Travel Speed	Approx. 1' per sec
Shipping Weight	xxx lbs

WARNING Do not exceed the specifications.
The warranty on your unit will be void if the installation exceeds the recommended specifications

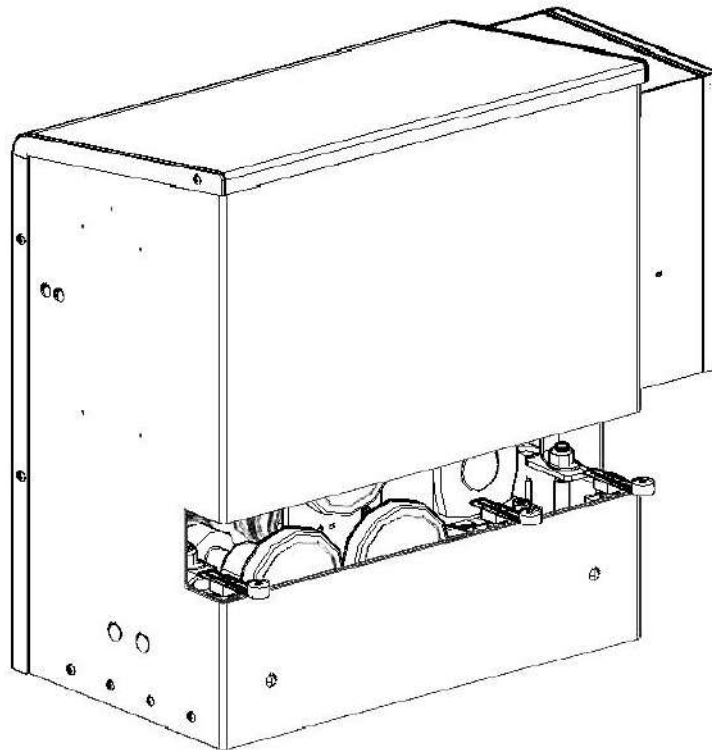

ALL SECURE PAD LOCATION SPECIFICATIONS

CONCRETE PAD LOCATION

Dimensions given for the pad location are based on a new pad, "right hand" installation with an existing wall and gate location.

1. Use a CARPENTERS ANGLE to insure the concrete pad is square and parallel to the gate.
2. The leading edge (closest to the gate) should be placed to be $1\frac{3}{4}$ " from the face of the installed gate.
3. The right side of the concrete pad should be approximately 12 inches from the end of the permanent fence or wall.
4. Concrete pad dimensions should be 30" long x 20" wide by 16" deep with the pad's top being level.
5. For drainage it is recommended that the concrete pad's top be 6" above the road level.

MOUNTING STUD LOCATIONS

1. To determine the first mounting stud location begin at the top right corner of the concrete pad. Using a carpenters angle measure down 2" from the leading edge (nearest the gate) and $1\frac{1}{4}$ " from the right side edge. Mark this location.
2. For the second stud location measure down 2" from the leading edge and $23\frac{1}{2}$ " from the center of the first stud location Mark this location.
3. For the third stud location use the carpenters angle to measure down $10\frac{1}{2}$ " from the first location squaring the hole location to the first two locations
4. For the last stud location use the carpenters angle to measure down $10\frac{1}{2}$ " from the second location squaring the hole location to the first two locations.
When locations are complete a $23\frac{1}{2}$ " x $10\frac{1}{2}$ " rectangular location pattern spaced 2 inches from the leading edge.
5. Install $\frac{3}{8}$ -16 x 6" threaded studs in the marked location making sure to install the studs deep enough to leave 1" of threaded stud visible above the surface of the concrete pad.

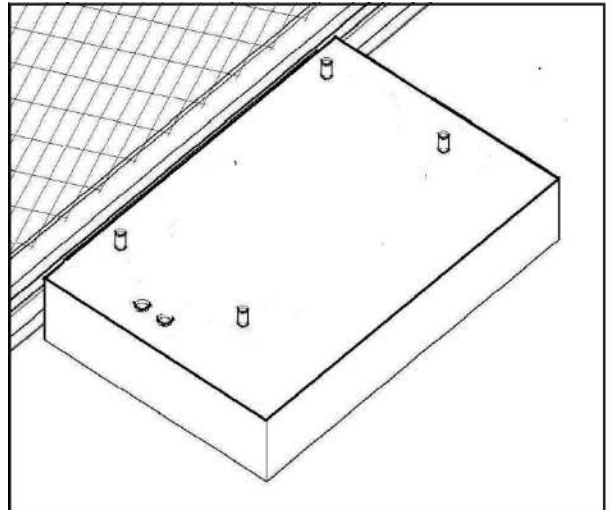

ELECTRICAL CONDUIT LOCATION

1. Electrical conduit locations are to be located on the left side of the concrete pad coming up approximately 2 inches on center from the left edge of the pad as shown.

ALL SECURE INSTALLATION SPECIFICATION

WARNING: Do not exceed the specifications.
The warranty on your unit will be void if the installation exceeds the recommended specifications.

All Sliding Gate Operators are factory preset for (LH) Left Hand Installations.

CONCRETE PAD CONSTRUCTION

Dimensions given for the pad are based on soil bearing shear of 2000 P.S.F. These figures may have to be adjusted depending on local soil conditions.

1. Construct form for mounting pad according to dimensions shown in Figure 1 and 2
2. Locate mounting pad according to dimensions given in illustration.
3. Level top edge of form.
4. Set reinforcing bars and wire mesh.
5. Mix concrete, pour mixture into form. Level and finish surface after pouring is complete.
6. Allow pad to cure for 48 hours, and remove forms.

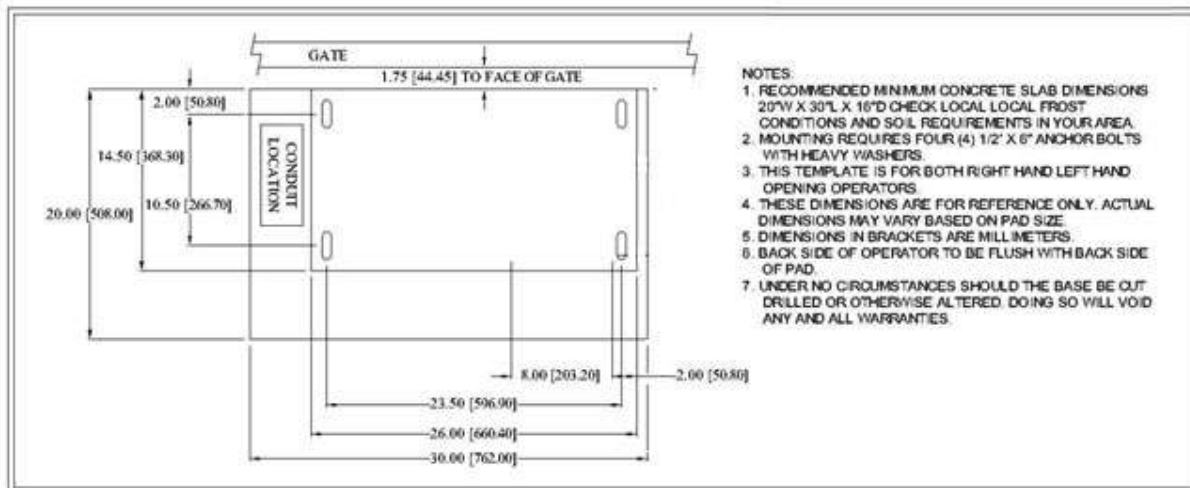
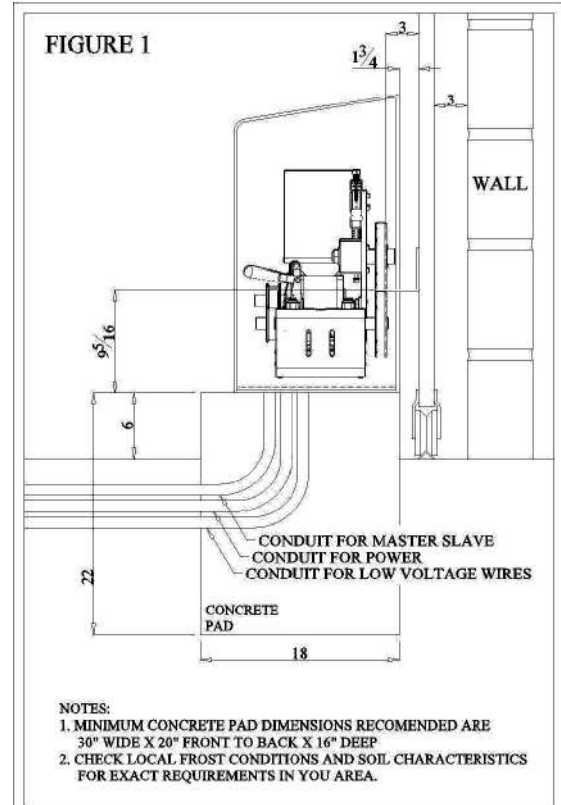

RAIL LOCATION REQUIREMENTS

RAIL SPECIFICATION:

Dimensions for the web are based on using a 4" x 4" x 1/4" thick "Angle Iron" or equivalent with a 4" web section intended as the contact area for the drive wheels of the ALL SECURE unit.

1. The contact web of the drive rail must extend no less than 4 inches from the gate for clearance.
2. Web sections, transitional radii, welds, and gussets must not extend more than 1 1/2" from the face of the gate to avoid interference with the ALL SECURE casing.
3. The Ideal height for the rail is 9 3/4" from the underside of the drive rail to the top surface of the ALL SECURE mounting pad.

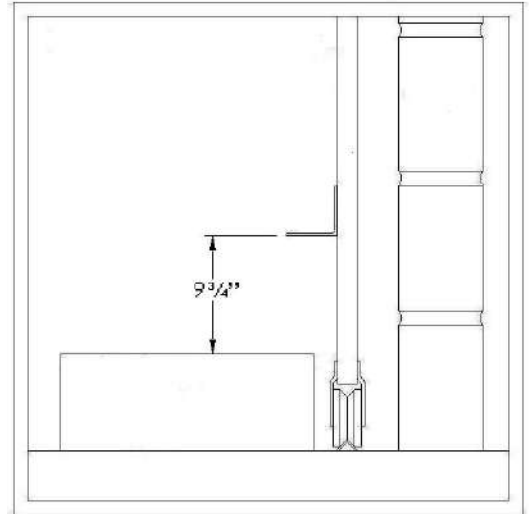

RAIL PLACEMENT:

1. Clamp or otherwise secure the rail in the position shown in Figure 2 with the bottom of the rail lining up as shown.
2. Repeat this process in at least three separate locations along the rail as it is attached to the gate to ensure the rail is within tolerance along the entire travel length of the gate.
3. Once the rail is in the correct position weld or otherwise attach the rail to the gate as required checking to be sure no attachment welds or hardware interfere with the rail path.
4. If any problems in this process occur, please call RAMSET customer service immediately.

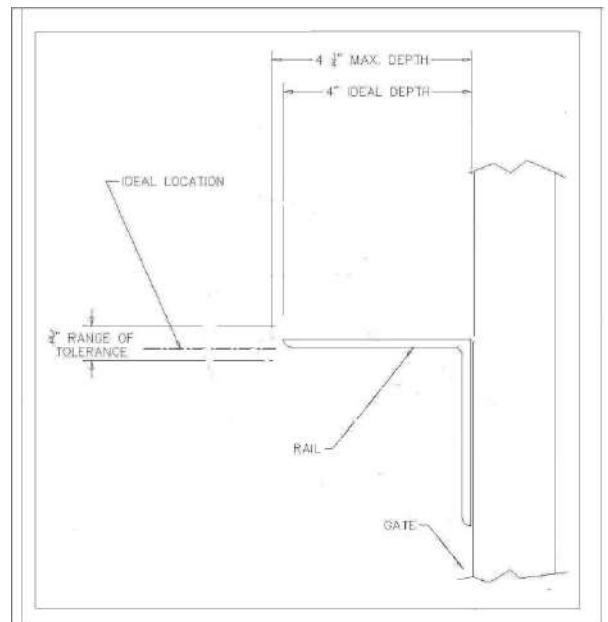

CASE MOUNTING SPECIFICATION

RAIL SPECIFICATION:

1. Remove the ALL SECURE unit from its shipping container taking care not to scratch or damage the finish.
2. Check the threaded stud height to insure the height is no more than 1" above the surface of the pad. Trim stud height if needed.
3. Remove the drive assembly and place the mounting slots of the case over the 3/8-16 studs on the mounting pad as shown.
4. Position the face of the case 1 3/4" from the face of the gate as required.
5. Apply "Loctite" and secure the case with the 3/8-16 UNC washers and nuts provided to a torque spec of 27 Ft-lbs.

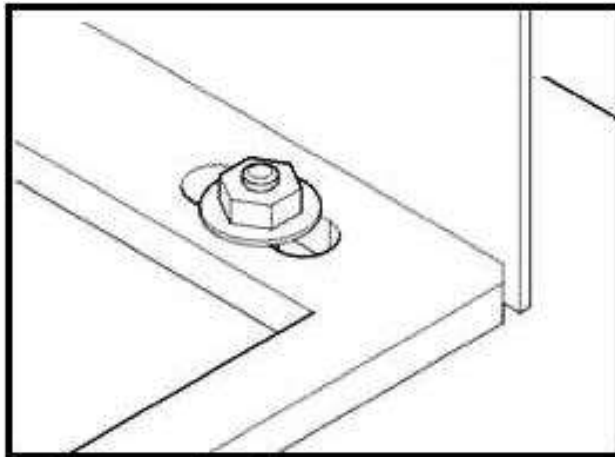
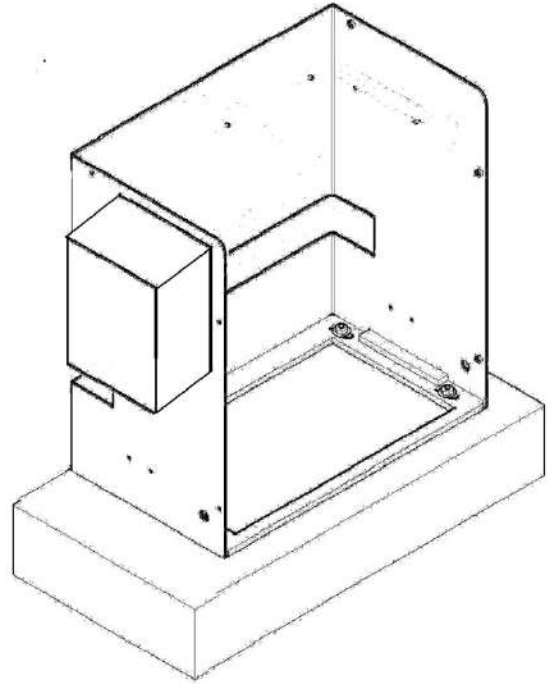

LIMIT BLOCK LOCATION

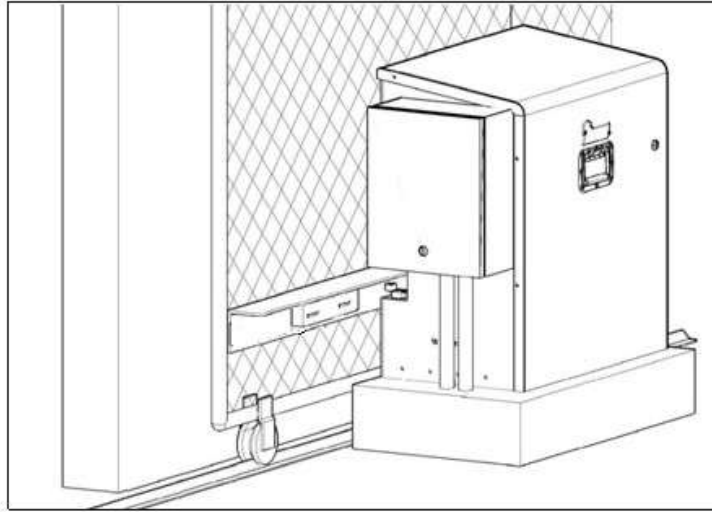

Installing the limit blocks and adjusting the limit switches is most easily done after the case has been mounted and before the drive is placed into the case / enclosure. Final adjusting the stop blocks should be done with the gate powered by the operator.

Limit Blocks

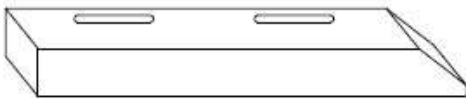

Left Limit Block

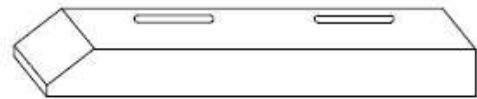

Right Limit Block

SPECIFICATION:

Without slow stop.

Left hand operation is shown. Switch the words open and close for right hand operation.

1. Once installation is complete, set the slow dip switch down on the control board to the off position.
2. Move the gate to its fully closed position and make a vertical line on the rail at the left edge of the enclosure.

Note: these instructions are based on a medium weight gate travelling on a flat surface. Inclines, variations in weight as well as variations in rolling resistance can substantially affect the coasting distance of the gate. In instances where the conditions differ substantially it is recommended to run the gate near the fully open and fully closed point to determine the coasting distance. Run

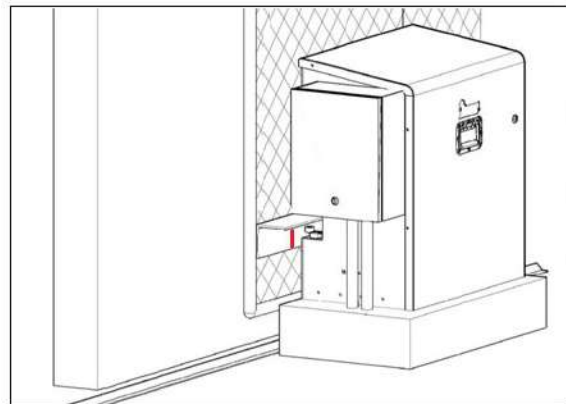

the gate towards the fully opened position at full speed. Press the stop button a few feet before fully opened position. Roughly measure the coasting distance from where the stop button was pressed and where the gate came to rest. Use this as your distance to mark the offset line.

3. Mark a vertical line "offset line" 12 inches to the right of the previously drawn line. (Alternatively you can use the coast measurement as described above for the offset distance.)
4. Place the leading (beveled) edge of the left limit block on the vertical offset line location towards the operator. Mark your mounting hole locations in the middle of the mounting slots.
5. Check to make sure the blocks will engage the limit switch's roller arms but will not interfere with the All Secure Case.
6. Drill mounting holes using a 5/16" steel bit.
7. Mount the block using 1/4-20 unc x 1 1/2" long carriage bolt, washers and nuts.
8. Check again for interference.
9. Adjust block forward or back as required to calibrate the gate to stop at the correct point.
10. Repeat steps 2 through 9 for the right side limit block. Beveled edge of the right limit block faces to the left.

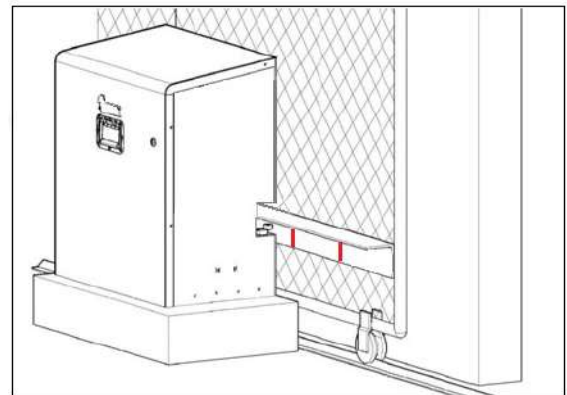
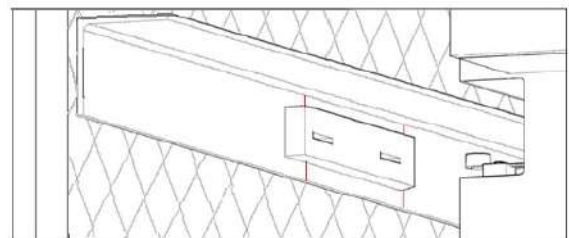
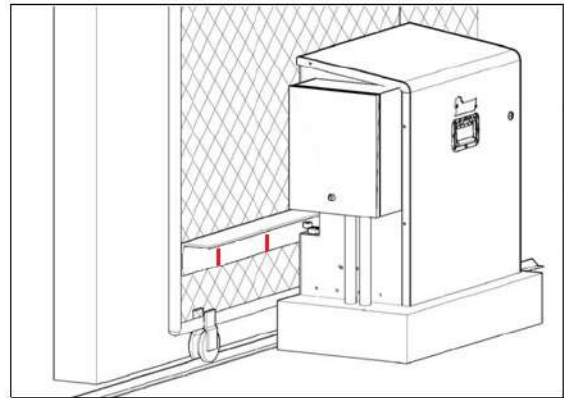

With slow stop.

Left hand operation is shown. Switch the words open and close for right hand operation.

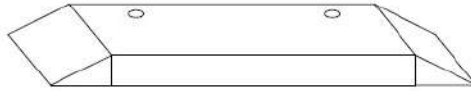

Slow Stop Block (2)

1. Once installation is complete, set the slow dip switch on the control board up to the on position.
2. Run the gate to its fully closed position and make a vertical line on the rail at the left edge of the enclosure.

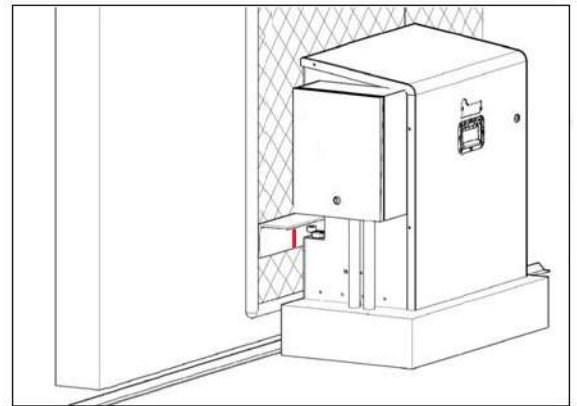

3. Mark a vertical line offset by 3 inches to the right of the previously drawn line.
4. Mark a vertical line 2 feet to the right of the offset line. This is the slow stop line used to position the slow stop block.
5. Place the leading (beveled) edge of the left limit block on the vertical offset line location towards the operator. Mark your mounting hole locations in the middle of the mounting slots.
6. Check to make sure the blocks will engage the limit switch's roller arms but will not interfere with the All Secure Case.
7. Place the right edge of the slow stop block at the slow stop block line. Mark your mounting hole locations in the holes of the slow stop block.
8. Drill mounting holes using a 5/16" steel bit.
9. Mount the blocks using 1/4-20 unc x 1 1/2" long carriage bolt, washers and nuts.

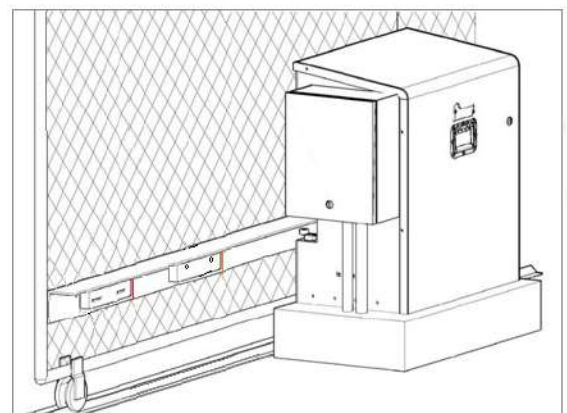
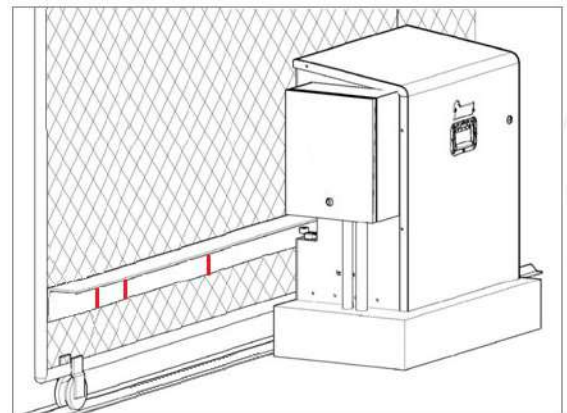

10. Adjust the stop limit block forward or back as required to calibrate the gate to stop at the correct point.
11. Repeat steps 2 through 10 for the right side limit block and slow stop block. Beveled edge of the right limit block faces to the left. For step 3 change the distance from the offset line to the stop block line from 2 feet to 3 feet.

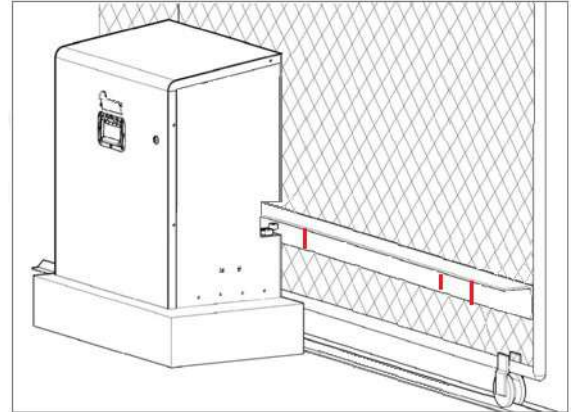

Limit Switch Arm Length Adjustment

There are three limit switches located in the All Secure. They are mounted on a switch plate attached to the rail side of the equipment enclosure. The entire switch plate can be adjusted up and down by loosening the 2 mounting screws. In most cases this will not be necessary. The left limit switch is triggered by the left limit block. The right limit switch is triggered by the right limit block. The middle limit switch is triggered by the slow stop blocks and are only used if the slow stop option is used.

1. Move the gate so that the left limit switch is positioned in front of the left limit block. Adjust the length of the limit switch arm so that it just barely touches the surface of the block.
2. Move the gate so that the limit switch is clear of all blocks. Adjust the length of the limit switch arm so that it extends an additional $\frac{1}{4}$ of an inch towards the rail. Securely tighten the limit arm adjusting screw.
3. Repeated steps 1 and 2 for the right limit switch and right limit block. If the slow stop option is used adjust the middle limit switch using steps 1 and 2 with one of the slow stop blocks. If the slow option is not used adjust the middle limit switch arm so that it is fully retracted i.e. farthest from the rail.

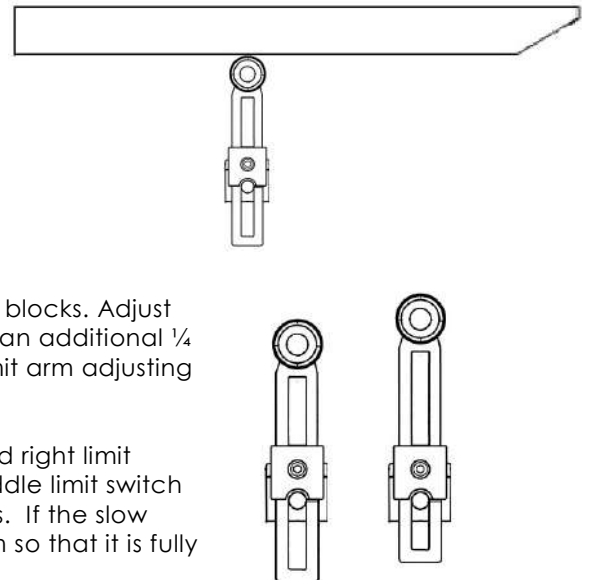

DRIVE MOUNTING SPECIFICATION

SPECIFICATION:

1. Lift and partially slide the drive unit into the enclosure on the glide rails.
2. Remove shipping blocks on the right side of the drive assembly, located between the main mounting plate and the "C" bracket at the right side of the drive unit.
3. Activate the locking clamp on the right side "C" bracket to lock down the main plate of the drive unit and push down the drive wheels.
4. Disengage the toggle clamps on either side of the idler wheel tower to free the idler wheel
5. Lift drive into the rear of the case sliding the chassis into position along the glide rails
6. Pass 3/8-16 UNC button-head socket cap screws through the square panel hole in the side walls of the case and through the corresponding slot in the drive unit.
7. Apply Locktite 242 to button-head socket cap screws .
8. Attach 3/8-16 UNC washers and nuts but do not tighten.
9. Remove the left side shipping blocks located between the main mounting plate and the "C" brackets at each end of the drive unit.
10. Lift drive unit until both lower drive wheel come into contact with the drive rail and secure drive unit at that height by tightening the 3/8-16 nuts to 27 Ft-lbs. Release the locking clamp allowing the main plate of the drive unit to "float" free.
11. Latch idler wheel into place using the two over center clamps at the top of the idler tower.
12. Adjust idler wheel tension bolt by tightening to 10 Ft-lbs.

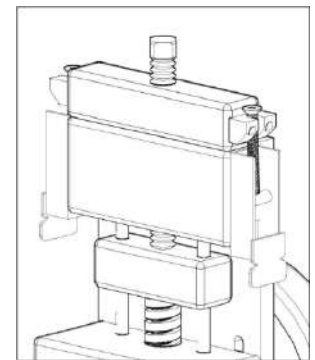
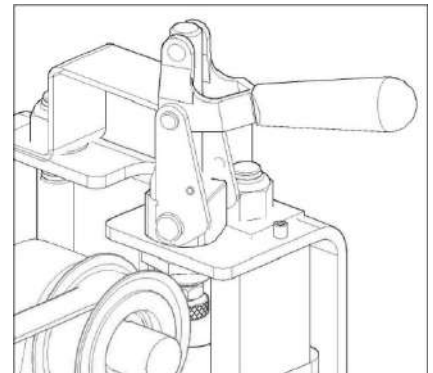
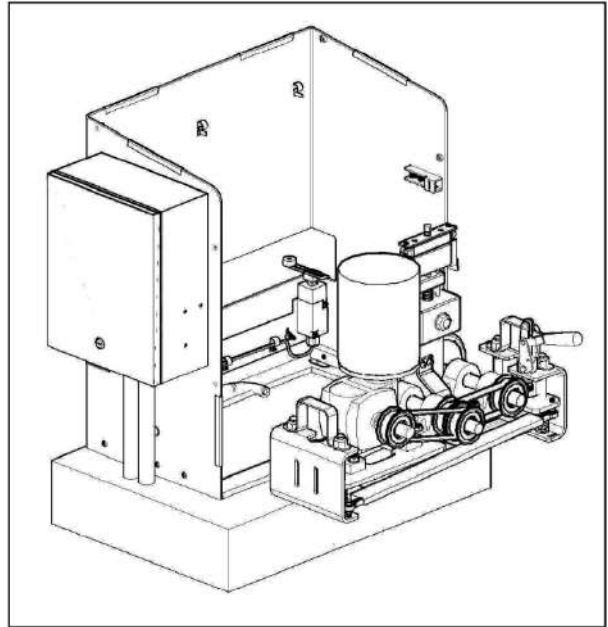

PLUG CONNECTIONS

PLUG IN DETECTORS
Used with the RLD-24
detectors only

RELAY CONNECTIONS
Lights, Alarms & Sirens

LOOP INPUTS
Loop wires - only used
with the plug-in RLD-24
detectors

INPUT POWER
18VAC from the
transformer

3-BUTTON
Common, Close,
Stop & Open. Used
with a 3-button
station

FOOT PEDAL
Foot pedal switch
input

**PRIMARY/SECONDARY
CONNECTION**
Synchronizes movement
between two gates.
3 wires (A, B & C)

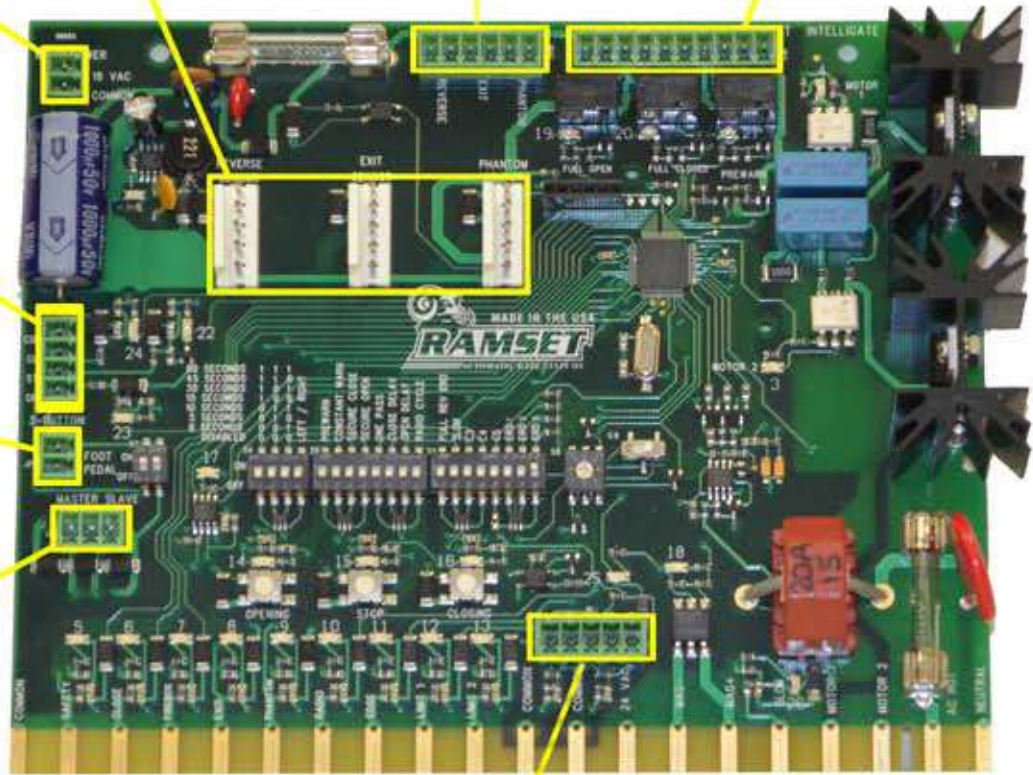

MPE
(Monitored Photo Eye)
Mandatory Entrapment
protection photo eye

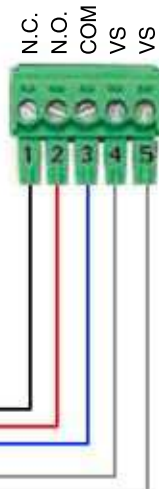

! Never try to bypass or tamper with an anti-entrapment safety device. This may result in serious injury.

PLUG CONNECTIONS

JP2 - Relay Connectoins:

- 1 - 24VDC
- 2 - 24 VAC
- 3 - Do Not Use
- 4 - Fully Open - N.O.
- 5 - Relay Common
- 6 - Fully Closed - N.C.
- 7 & 8 - Constant Warn/Prewarn - N.O.
- 9 & 10 - ERD Alarm (factory wired)



All Relays are rated at 125VAC, 1A.
Used with:

- Lights or Sirens that show the gate is open.
- Constant Warn/Prewarn lights or sirens.
- Alarm that sounds when an obstruction is sensed twice in a single travel.

See "WIRING DIAGRAMS"

JP3 - 3 Button:

- 1 - OP (open) - Normally open connection
- 2 - ST (stop) - Normally closed connection
- 3 - CL (close) - Normally open connection
- 4 - COM - (common)



Used with:

- A 3-button station.
- An anti-entrapment device where the gate should stop and remained stopped.

To use the ST (stop) function, S7 - #1 must be in the 'OFF' position.

JP7 - Primary/Secondary:

- 1 - A 2 - B 3 - C

Synchronizes the operation between two gates.

Three wire, shielded cable needed.
Align A to A, B to B & C to C from the primary unit to the secondary unit.



JP9 - Input Power:

- 1 - Common
- 2 - 18 VAC

Connection from external transformer to power up the control board.



JP10 - Loop Inputs:

- 1 & 2 - Reverse loop wires
- 3 & 4 - Exit loop wires
- 5 & 6 - Phantom loop wires

Only used with the Ramset RLD-24 & ILD-24s plug-in loop detectors.



JP11 - Foot Pedal

- 1 - Common (Foot pedal switch)
- 2 - Normally Open (Foot pedal switch)

Only used on models with a foot pedal (RAM 100, 1000, 5500, 300)

On the above mentioned operators, S7 must be in the 'OFF' position

On all other models, S7 must be in the 'ON' position

Factory wired to the foot pedal switch.



JP 13 - Monitored Photo Eye Entrapment Protection:

- 1 - N.C. (Normally Closed)
- 2 - N.O. (Normally Opened)
- 3 - Common
- 4 - VS (Voltage Supply)
- 5 - VS (Voltage Supply)



****Every installation must have Monitored Entrapment Protection.
Without it the operator will not function.**

WIRING DIAGRAMS

Gate Open Light/Siren:

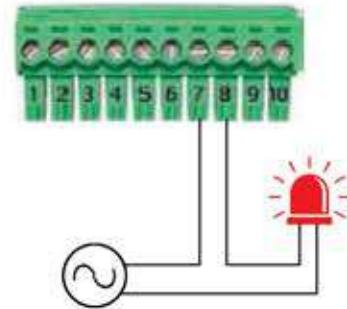

1. Wire from JP2-7 to Power supply (+)
 2. Wire from JP2-8 to light/siren (+)
 3. Wire from power supply (-) to light/siren (-)
- * 24VAC, 1A max current draw.

Constant Warn or Prewarn:

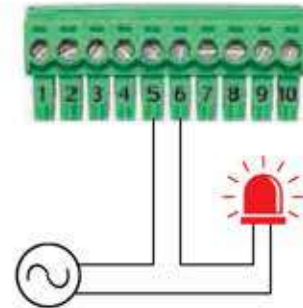

1. Wire from JP2-5 to Power supply (+)
 2. Wire from JP2-6 to light/siren (+)
 3. Wire from power supply (-) to light/siren (-)
- * 24VAC, 1A max current draw.

PUSH BUTTON CONTROLS

Three pushbuttons are located under the dip switches for operation of the gate (see Figure 15). The **opening**, **stop** and **closing** buttons can be utilized to set limit switches and verify proper system operation when installing or servicing an operator.

OPENING

Opens the gate.

STOP

Stops the gate.

CLOSING

Closes the Gate.

RESETTING THE E.R.D. (Electronic Reversing Device)

With power 'on' push all three pushbuttons for approximately 5 seconds. All three LEDs should blink. Once they start blinking, let go of the three pushbuttons.

***WARNING - When pushing the three buttons, the gate can move at any time. Always keep body parts and clothing clear of pulleys, sprockets and all moving and electrical components in the operator to help prevent serious injury.**

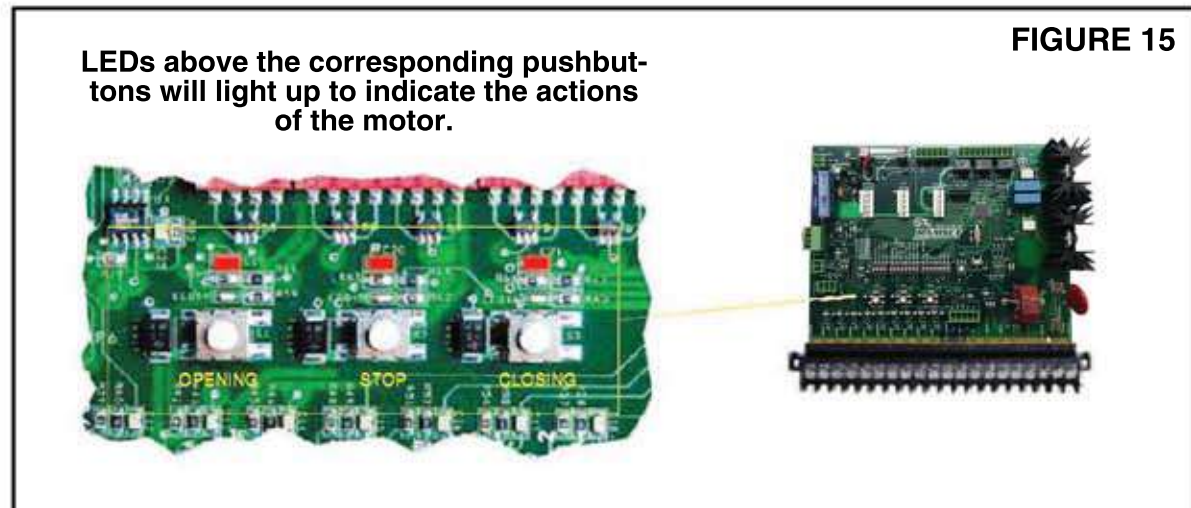

DIP SWITCH CONFIGURATION

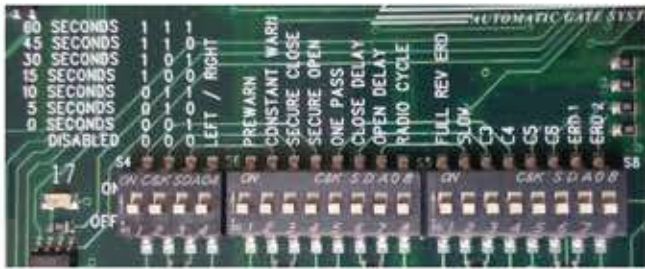

DIP SWITCH S4 - "A"

A1, A2 & A3 - Automatic Timer to close gate
 '0' is "off", '1' is "on"

Switch	1	2	3	Open Duration
	0	0	0	disabled
	0	0	1	00 seconds
	0	1	0	05 seconds
	0	1	1	10 seconds
	1	0	0	15 seconds
	1	0	1	30 seconds
	1	1	0	45 seconds
	1	1	1	60 seconds

A4 - LEFT/RIGHT

OFF - Left-hand installation
 ON - Right-hand installation. Reverses the motor and limit wires without moving any wires.

DIP SWITCH S6 - "B"

B1 - PREWARN

OFF - Normal operation
 ON - Triggers the relay on JP2, pins 7 & 8, for 3 seconds before the gate moves in any direction.

B2 - CONSTANT WARN

OFF - Normal operation
 ON - Triggers the relay on JP2, pins 7 & 8

B3 - SECURE CLOSE

OFF - Normal operation
 ON - When power is lost and then regained, if all devices are clear and it's safe, the gate will close.

B4 - SECURE OPEN

OFF - Normal operation
 ON - If the gate comes off of the limit without a valid command, the gate will re-open.

B5 - ONE PASS

OFF - Normal operation
 ON - While the gate is opening, if the safety input is triggered and then cleared, the gate will immediately start closing. If the safety input is then activated again, before the gate is fully closed, the gate will stop and stay at rest until the safety loop is cleared. At any time if a valid open signal is received, the gate will open.

B6 - CLOSE DELAY

OFF - Normal operation
 ON - Adds a 1 second delay before the gate closes.

B7 - OPEN DELAY

OFF - Normal operation
 ON - Adds a 1 second delay before the gate opens.

B8 - RADIO CYCLE

OFF - Gate will open, if on the close limit, and close, if on the open limit. If in travel, the gate will always open or continue to open.
 ON - Gate will open, if on the close limit, and close, if on the open limit. If in travel, the gate will stop with the first command and then reverse with a second command.

DIP SWITCH S5 "C"

C1 - FULL REV ERD

OFF - Normal operation
 ON - When closing, if the gate senses an obstruction (ERD), the gate will stop and reverse all the way to the fully open limit.

C2 - SLOW

OFF - Normal Operation
 ON - Adds a slow start when the gate opens and a slow stop when the gate closes. The slow stop is triggered by the slow stop switch. (ONLY ON THE ALL SECURE RAIL DRIVE OPERATOR)

C3, C4, C5 & C6

OFF - No function. These 4 switches should not be turned to the 'on' position.

C7 & C8 - ERD 1 & ERD 2

Switch	7	8	Sensitivity
	Off	Off	Most Sensitive
	Off	On	Medium Sens.
	On	Off	Low Sensitive
	On	On	Least Sensitive

DIP SWITCH CONFIGURATION cont.



DIP SWITCH S7

Eliminates having to jumper the foot pedal plug (JP11) and the stop input (JP3).

- 1 - Foot pedal plug bypass
- 2 - Stop input plug bypass

Do not bypass the foot pedal plug on any unit that has a foot pedal. Bypassing the foot pedal plug can cause damage to you operator, voids all warranties, and may cause serious injury.



ROTARY SWITCH S8

Manual ERD adjustments

Range 0 to 7

- 0 - most sensitive
- 7 - least sensitive

SLIDE SWITCH S9

Switches from automatic ERD adjustment (Dip switch C7 & C8) and Manual ERD adjustment (Rotary switch S8)

- Left - Automatic ERD (Dip C7 & C8)
- Right - Manual ERD (Rotary S8)

TERMINAL STRIP CONNECTIONS FOR OPTIONAL ACCESSORIES

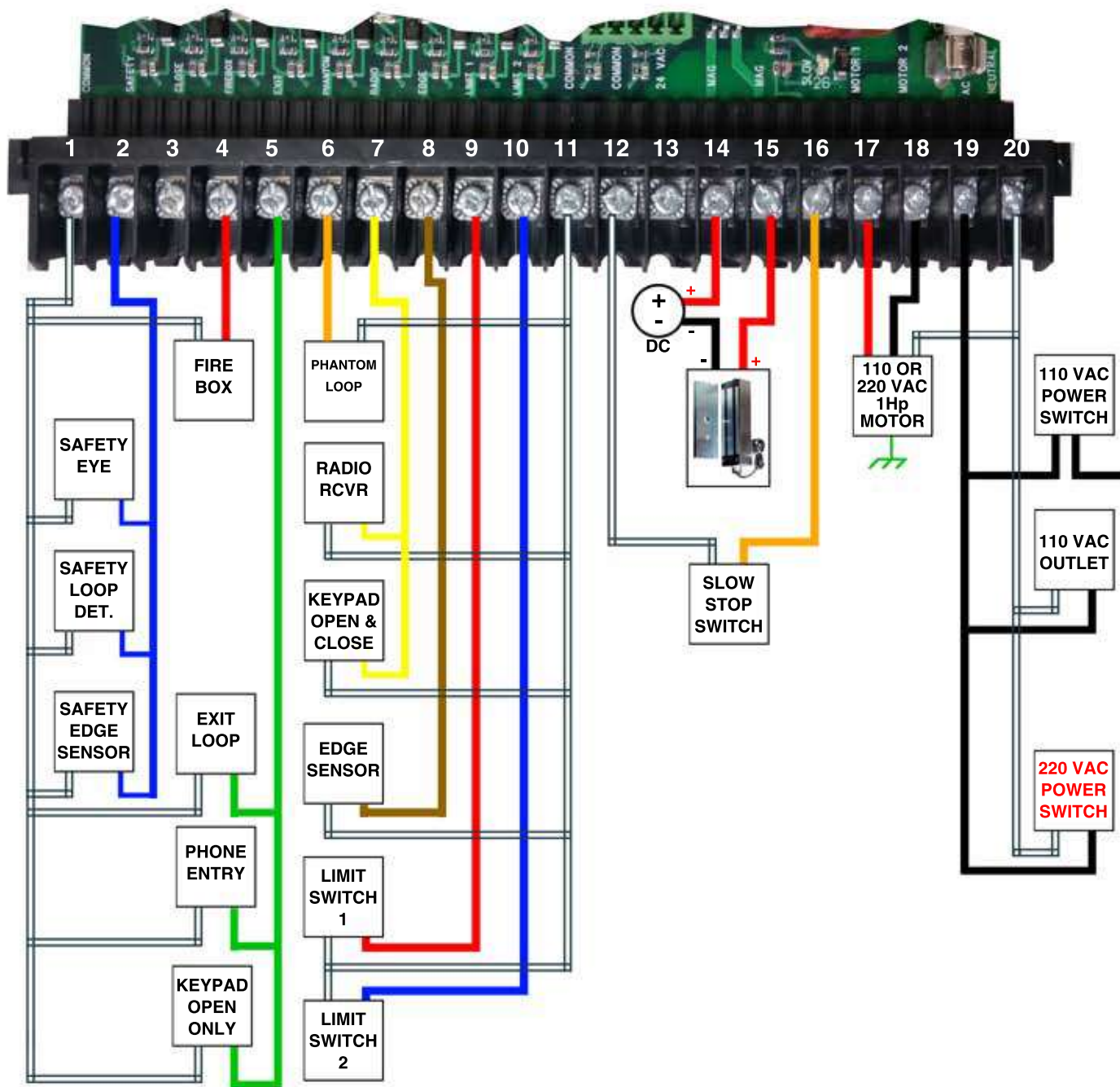

TERMINAL STRIP CONNECTIONS cont.

TERMINAL 1 - COMMON

Low voltage common

TERMINAL 2 - SAFETY

Stops the gate from closing.

- GATE OPEN - Holds gate open.
- GATE CLOSED - Gate stays closed.
- GATE OPENING - Gate continues to open.
- GATE CLOSING - Gate stops, then opens.

The function can be altered with Dip Switch B5 (see dip switch configuration).

Used with loop detectors, photo eyes, safety edges...etc.

Becomes active with a closed contact to common.

TERMINAL 3 - CLOSE

Closes the gate.

Used with 3-button stations or pushbuttons.

Becomes active with a closed contact to common.

TERMINAL 4 - FIREBOX

Opens the gate with a maintained signal.

Used with fire dept. key switches & controls.

Becomes active with a closed contact to common.

Closes immediately after the closed contact to common is removed.

TERMINAL 5 - EXIT

Opens the gate.

Uses with exit loop detectors, phone entry systems, keypads, 3-button stations...etc.

Becomes active with a closed contact to common.

TERMINAL 6 - PHANTOM

Holds the gate open when the open limit switch is active.

Covers the area of a swing gate's path.

Used with loop detectors and photo eyes.

Becomes active with a closed contact to common.

TERMINAL 7 - RADIO

Opens, closes and/or stops the gate.

Operation depends on dip switch B8 & A1-3 (see dip switch configuration).

Used with an RF receiver, pushbutton, keypad...etc.

Becomes active with a closed contact to common.

TERMINAL 8 - EDGE

When triggered the gate will stop and remain stopped until the detector is cleared. Once the detector is cleared, the operator will resume normal operation. If triggered twice during one travel, the control board will lock up and the alarm will sound for 6 minutes. After 6 minutes the unit will return to normal operation.

Becomes active with a closed contact to common.

TERMINAL 9 & 10 - LIMIT 1 & LIMIT 2

Stops the gate in either the fully open or fully closed position.

Direction depends on dip switch A4 (see dip switch configuration).

Factory wired and should not be moved.

Becomes active with a closed contact to common.

TERMINAL 11 & 12 - COMMON

Low Voltage Common

TERMINAL 13 - 24 VAC

Provides 24 VAC for peripheral accessories.

TERMINAL 14 & 15 - MAG1 & MAG2

Provides a closed contact when the gate is closing or closed (like a switch).

Used with a Magnetic Lock.

Needed: A power supply that is rated for the magnetic lock that is being connected. Make sure the power supply is the right voltage and current rating.

see wiring diagram on previous page.

TERMINAL 16 - SLOW

Only available on the All Secure rail drive operator.

Creates a slow stop using the slow stop switch mounted in the operator.

Factory wired and should not be moved.

TERMINAL 17 & 18 - MOTOR 1 & MOTOR 2

Factory wired and should not be moved.

Supplies voltage to the motor.

Direction depends on dip switch A4 (see dip switch configuration).

TERMINAL 19 & 20 - AC HOT & NEUTRAL

110 VAC AND 220 VAC to power the operator.

Factory wired and should not be moved.

ENTRAPMENT AND SAFETY PROTECTION

WARNING

In order to prevent serious injury, bodily harm or death from a moving gate:
- Entrapment protection devices must be installed to cover any and all entrapment danger areas and locations during a gates opening and closing cycles.

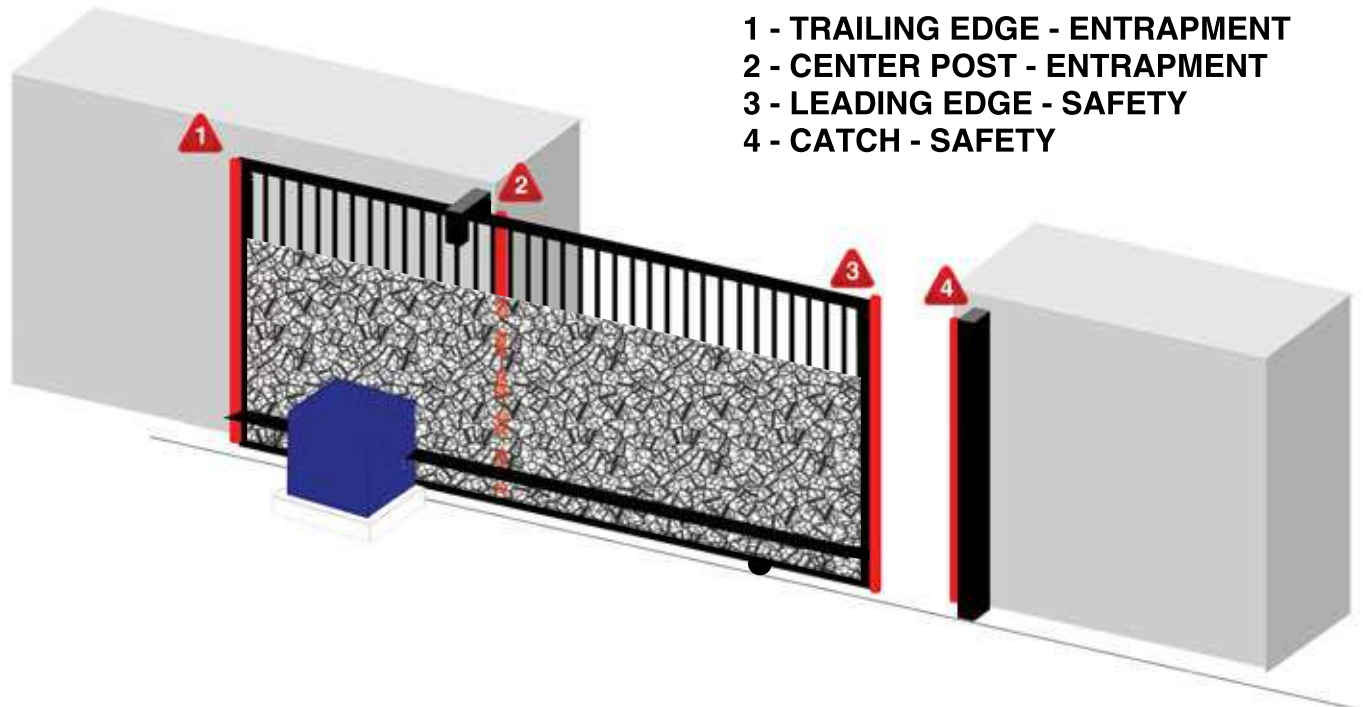

- 1 - TRAILING EDGE - ENTRAPMENT
- 2 - CENTER POST - ENTRAPMENT
- 3 - LEADING EDGE - SAFETY
- 4 - CATCH - SAFETY

- 5 - BACK PLANE ZONE - ENTRAPMENT
- 6 - INTERIOR ZONE - SAFETY
- 7 - EXTERIOR ZONE - SAFETY

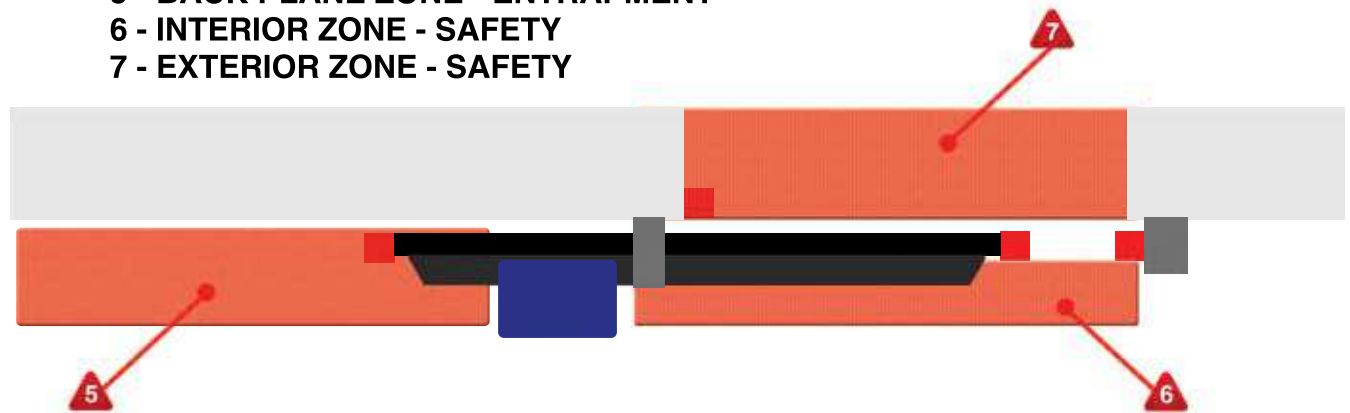

Since every installation is different, it is up to a qualified and trained technician to determine:
- All Possible Entrapment areas & locations
- The amount and type of entrapment protection devices that are needed.

ENTRAPMENT AND SAFETY PROTECTION cont.

General entrapment protection provisions

A vehicular gate operator shall have provisions for, or be supplied with, at least two independent entrapment protection means as specified in Table 1. At installation, both entrapment protection devices must be installed.

Table 1

Horizontal slide, vertical lift, and vertical pivot
Entrapment protection types ^a
A, B1, B2 or D
<p>Note - The same type of device shall not be utilized for both entrapment protection means. Use of a single device to cover both the opening and closing directions is in accordance with the requirement: however, a single device is not required to cover both directions. A combination of one Type B1 for one direction and one Type B2 for the other direction is the equivalent of one device for the purpose of complying with the requirements of either entrapment protection means.</p> <p>^a Entrapment protection types:</p> <p>Type A - Inherent entrapment protection system. Type B1 - Non-contact sensor (photoelectric sensor or the equivalent). Type B2 - Contact sensor (edge device or the equivalent). Type D - Actuating device requiring continuous pressure to maintain opening or closing motion of the gate.</p>

A gate operator utilizing entrapment protection designated Type B1 in Table 1 by having provision for connection of, or providing with the operator, a non-contact sensor (photoelectric sensor or equivalent) shall, upon sensing an obstruction in the direction of travel of the gate:

- a) Stop or reverse the gate within a maximum of 2 s,
- b) Stop the gate, or stop and initiate reversal of the gate upon sensing a second sequential obstruction,
- c) Result in a gate at rest remaining at rest unless a Type D device is actuated, and
- d) Return to normal operation when the sensor is no longer actuated.

A gate operator installed in accordance with the manufacturer's instructions utilizing external entrapment protection designated Types B1 or B2 in Table 1 by having provision for connection of such device, or providing such device with the operator, shall monitor for the presence and correct operation of the device at least once during each open and close cycle. Should the device not be present, or a fault condition occur that precludes the sensing of an obstruction, including an interruption of the wireless signal to the wireless device or an open or short circuit in the wiring that connects the external entrapment device to the operator and the device's supply source, the operator shall require constant pressure or actuation to initiate and continue movement of the gate in either the opening or closing direction. Upon removal of pressure, movement of the gate shall cease. Unless supplied with separate Open and Close buttons, each subsequent pressing of the control button shall reverse direction of the gate.

PARTS LIST

PART NO.	DESCRIPTION	REQ.
032611-00	ASSEMBLY, IDLER WHEEL TENSIONER	
040611-01	1/4-20 UNC X 3/4 LG. SOCKET HEAD CAP SCREW	4
040611-03	3/4-10 UNC HEX NUT GR 8 CHR M PLT	1
040611-02	3/4 WASHER ZINC PLT	4
040611-04	SHOULDER BOLT 1.0 DIA X 4.0" LG	1
040611-05	1" WASHER ZINC PLT	1
040611-07	SPRING CHROME SILICON DIE SPRING 3/4 DIA	1
041511-15	1/4-20 UNC X 7.5 LG. SHOULDER BOLT	1
040611-10	1/2" SET SCREW CUP POINT BLACK ALLOY STEEL	1
040611-11	DRAW LATCH OVER CENTER DRAW	2
040611-12	1/4" WASHER ZINC PLT	10
040611-13	SHOULDER BOLT 1/4" DIA X 1/2" LG	4
031311-01	BRKT,RISER,IDLER,RISER,WHL TNSN	1
032411-01	MTG BLOCK,IDLER AXLE, TENSIONER	1
032411-02	BLOCK,IDLER, SPRING TENSION	1
032611-01	MTG BLOCK,IDLER ADJUST	1
032611-02	MTG BLOCK,THRD RELEASE,IDLER ADJUST	1
040611-14	SPACER,BUSHING ,BRONZ	1
012615-01	#10-32 X .5 LG FLAT HEAD CAP SCREW	2
040711-06	1/4-20 UNC X 1 LG. FLAT HEAD CAP SCREW	3
040711-07	1/4-20 UNC NUT	3
031311-02	BRKT,SUPPORT, RISER,IDLER WHL TNSN	1
041111-01	SLIDER PLATE,IDLER AXLE,TENSIONER	1
	6" DIA DRIVE WHEEL	1
120513-02	M5 X 60 FLAT HD CAP SCREW	2
12114-02	UHMW SHEET LRG	1
12114-01	UHMW SHEET	1
07814-01	RETAINING PLATE	1
	LOCKTITE, REMOVABLE	AR
030911-00	ASSEMBLY, MOTOR & TRANSMISSION	
112513-01	DIRECT/FLUSH MNT REVERSE ACT TOGGLE CLMP	1
112213-01	3/8 WASHER	12
112213-03	3/8-16 HEX NUT	12
112213-02	3/8-16 X 1.75 LG ROUND HEAD SQUARE NECK BOLT	12
040911-09	1" CAST IRON PILLOW BLOCK	4
040611-08	SPRING CHROME SILICON DIE SPRING 1" DIA	4
040611-06	THREADED BALL JOINT LINKAGE	4

PARTS LIST

032911-03	TMW-60 ANGLE DRIVE GEAR BOX	1
040611-06	THREADED BALL JOINT LINKAGE	4
032911-06	5/8-11 UNC LOCK NUT	4
120513-01	5/8-11 UNC X 7 LG FLAT SOCKET HEAD CAP SCREW	4
032011-01	BRKT,SUSPENSION,RIGHT	1
031811-01	BRKT,SUSPENSION,LEFT	1
031611-01	PLATE, MAIN, MACHINED	1
111213-01	6" DIA DRIVE WHEEL	2
030911-02	PLATE,TORTION,MACHINED	1
030911-03	5/8 WASHER ZINC PLT	4
OL103048	ELECTRIC MOTOR	1
	5/16-24 UNC HEX NUT	4
	5/16 WASHER	4
040711-06	1/4-20 UNC X 1 LG FLAT HEAD CAP SCREW	2
040711-07	1/4-20 UNC NUT	2
062811-01	SHAFT, DRIVE, 1 X 10 IN SS	1
062811-02	SHAFT, DRIVE, 1 X 12 IN SS	1
112513-02	FLAT TIP CLAMP SPINDLE	1
	GATES BELT (Gear Box to Wheel Drive)	1
	GATES BELT (Wheel to Wheel Drive)	1
	SPROCKET (Wheel to Wheel Drive)	2
	SPROCKET (Gear Box to Wheel Drive)	2
	BUSHING (1 " ID) (Wheel to Wheel Drive)	2
	BUSHING (1 " ID) (Gear Box to Wheel Drive)	2
070214-01	HANDLE LIFT DRIVE UNIT	2
120914-01	STRAP, BRACKET, SPACING	1
011514-02	5/16-24 x .50 LG SCKT HD CAP SCREW	4
	LOCKTITE, REMOVABLE	AR
051115-00	ASSY,DOOR, ENCLOSURE, ALL SECURE	
ARTWORK	RAMSET LOGO PLATE	1
031115-00	WELDMENT, ASSY, DOOR	1
052715-01	HANDLE, LID ENCLOSURE	1
052715-02	10-32 UNF X 1/2 LG PAN HEAD SCREW	8
031615-04	10-32 UNF X 1/2 LG FLT HEAD SCREW	2
031615-05	10-32 NYLOX NUT	10
021615-00	ASSY, LOCK CASE	1
51215-00	ASSY, BASE, ENCLOSURE ALL SECURE	

PARTS LIST

052515-00	WELDMENT, ENCLOSURE FRAME	1
022015-01	RUBBER EDGE TRIM, 1/8 INSIDE WIDTH, 7/16"	A/R
022315-01	TEN CIRCUIT TERMINAL BLOCK	1
021415-01	BRKT, LOCK CASE	1
022415-01	CONDUIT CONNECTOR, 1"	1
032014-01	1/4-20UNC X 1 TAMPER RESISTANT BOLT	6
031615-01	1/4-20 UNC NYLOX NUT	4
031615-06	8-32 UNC NUT	4
031215-07	8-32 UNC X 3/4 LG TAMPER RESISTANT SCREW	4
062014-01	SLIDER BLOCK	2
030515-04	1/4-20 X 1 LG CARRIAGE BOLT	4
	10-32 UNC X 5/8 LG TAMPER RESISTANT SCREW	8
021416-01	HOLE PLUG LRG	1
021416-02	HOLE PLUG SML	4
091115-05	3/8" CABLE HOLDER	3
050715-00	ASSEMBLY, LIMIT SWITCH KIT	
022615-01	SNAP ACTION LIMIT SWITCH	1
022615-02	LEVER ADJ FRONT NYLON	1
022615-03	SNAP ACTION LIMIT SWITCH SMALL	2
030515-02	1/4 WASHER	2
031815-08	1/4-20 UNC NYLOX NUT	2
030515-04	1/4-20 UNC X 1 CARRIAGE BOLT	2
031615-03	M5 WASHER	6
031615-02	M5 X 0.8 X 50MM LG SOCKET HEAD CAP SCREW	6
031615-05	M5 HEX NUT	6
031615-07	#6 FLAT WASHER	4
031615-06	#6-32 UNF HEX NUT	4
031615-06	#6-32 UNF X 1/2 LG FLAT HEAD SCREW	4
031815-04	CABLE JACKET	AR
031815-01	PLATE MOUNTING LIMIT SWITCH	1
091115-01	STRAIN RELIEF CONNECTOR 1/2 INCH	2
091115-02	1/2 IN, NON-METALIC LIQUID-TIGHT PUSH-ON CONN	1
091115-04	COUPLING, THREADED, 1/2, GRY PVC	1
091115-05	VIBRATION DAMPING LOOP CLAMP	4
120513-02	M5 X 0.8 X 50MM LG SOCKET HEAD CAP SCREW	6
091115-05	3/8" CABLE HOLDER	4
031815-09	BRKT, MNTG, LIMIT SWITCHED	1
020616-01	#8-32 UNC X 1" CAP SCREW	2

PARTS LIST

020616-02	#8-32 UNC HEX NUT	2
020616-02	#8-32 UNC HEX NUT	2
020616-04	#10-24 UNC X 1" CAP SCREW	4
020616-05	#10-24 UNC HEX NUT	4
020616-06	#10 FLAT WASHER	4
020516-02	THREADED COUPLING RIGID CONDUIT	1
020516-03	STRAIGHT CONNECTOR WATERTIGHT CONDUIT	1
020516-04	COMPACT LIQUID TIGHT CORD GRIP	1
020516-05	1" LOOP CLAMP	1
RAM-124-14302-015	Control Panel Assy	
RAM-120-24301-715	BOX-CONTROL PANEL	1
RAM-120-24303-709	HOLDER-HINGE PLATE	1
RAM-120-24304-709	BRACKET RECEIVER	1
RAM-120-24305-204	SWITCH HOLDER BRKT	1
RAM-120-24302-209	HINGE PLATE	1
FH-M4-12 ZI	FH-M4-12 ZI	12
90725A025	M4 X 0.7 HIGH HEX NUT	10
RAM-120-24306-711	TOP BRACKET	1
RAM-120-24307-710	ANGLE BRACKET	1
RAM-120-34301-715	DOOR-CONTROL PANEL BOX	1
BSO-632-16ZI-BLIND THREADED	BSO-632-16ZI-BLIND THREADED	2
BSO-632-12ZI-BLIND THREADED	BSO-632-12ZI-BLIND THREADED	2
90325A171	#8-32 x 3/8 LG x 1/8 SHOULDER SCREW	2
90272A148	#6-32 X 1/2 LG PAN HEAD SCREW	2
90272A144	#6-32 X 1/4 LG PAN HEAD SCREW	2
92005A318	M5 X 0.8 X 100 PAN HEAD MACHINE SCREW	4
94920A300	M5 X .08 SERRATED FLANGE LOCKNUT	4
Transformer	Transformer-GD6625001-240V-120V	1
Motherboard	Motherboard	1
030515-05	5/16 X 3/8 SPACER	4
6920K21	Ground Lug	1
458-1361-ND	Buzzer,Mallory	1

PARTS LIST

032011-01	BRKT,SUSPENSION,RIGHT	1
031811-01	BRKT,SUSPENSION,LEFT	1
031611-01	PLATE, MAIN, MACHINED	1
111213-01	6" DIA DRIVE WHEEL	2
030911-02	PLATE,TORTION,MACHINED	1
030911-03	5/8 WASHER ZINC PLT	4
OL103048	ELECTRIC MOTOR	1
	5/16-24 UNC HEX NUT	4
	5/16 WASHER	4
040711-06	1/4-20 UNC X 1 LG FLAT HEAD CAP SCREW	2
040711-07	1/4-20 UNC NUT	2
062811-01	SHAFT, DRIVE, 1 X 10 IN SS	1
062811-02	SHAFT, DRIVE, 1 X 12 IN SS	1
112513-02	FLAT TIP CLAMP SPINDLE	1
	GATES BELT (Gear Box to Wheel Drive)	1
	GATES BELT (Wheel to Wheel Drive)	1
	SPROCKET (Wheel to Wheel Drive)	2
	SPROCKET (Gear Box to Wheel Drive)	2
	BUSHING (1 " ID) (Wheel to Wheel Drive)	2
	BUSHING (1 " ID) (Gear Box to Wheel Drive)	2
020914-01	ASSEMBLY, HOUSING	
020514-01	WELDMENT, BASE PLATE	1
020814-01	FRAME, MAIN, HOUSING	1
020414-01	WELDMENT, ASSY ELECTRONICS TRAY	1
020614-01	WELDMENT, ASSY, HOUSING LID	1
	1/4-20 UNC X 1/2 LONG CAP SCREW	6
	SWITCHES	2
040711-07	1/4-20 UNC NUT	2
040611-12	1/4" WASHER ZINC PLT	10
032014-01	1/4-20 UNC X 1 TAMPER RESISTANT BOLT	6

END USER'S RESPONSIBILITIES

- Ask your technician about all the features of your new Ramset gate operator.
- A monitored entrapment protection photo eye is included with every operator and must be installed by your technician to prevent entrapment, injury or death.
- Other entrapment protection and safety devices, such as additional photoe eyes, reverse loops, phantom loops, and/or edge sensors may need to be installed on your gate before the operator may be used. Ask your technician which safety devices best suit your safety needs.
- Read your warranty certificate and fill out your warranty extension card. Return the warranty card, via certified mail, to Ramset within 90 days of purchase: Ramset Automatic Gate Systems, Inc. 9116 De Garmo Ave Sun Valley, CA 91352
- All warranty issues/claims must be redeemed by a technician.
- Homeowners should NEVER take the cover off the gate operator.
- Homeowners should NEVER try to work on, repair or service the gate operator.
- Never let children operate or play with gate controls. Keep the controls away from children.
- Never let children play in the area around the gate.
- Never let anyone ride, climb under or climb over the gate.
- Always keep people, children and objects away from the gate while the gate is in operation. No one should cross the area of a moving gate.
- The entrance is for vehicles only. Pedestrians should use a separate entrance.
- Use the emergency release only when the gate is not moving. Make sure before using the foot pedal release, the circuit breaker for the operator is turned off.
- Have the technician give you a demonstration of how to use the emergency release.
- Make sure that in your breaker box, the breaker for the operator is clearly marked and that you are aware of how to disable and enable the breaker.
- Keep gates properly maintained. Have a qualified gate technician service the gate operator and gate hardware every six months to a year. This includes checking of safety devices, E.R.D. and battery backup systems...etc.
- Frequently test and check all safety devices.
- Periodically test and check the battery backup and emergency release systems.
- Keep the gate operator area free of debris.
- Keep the area clean and pest free (insects and rodents can cause serious damage to the operator which is not covered under warranty).
- Warning signs must be placed on both sides of every gate in a highly visible area.
- To reset the audible alarm on the gate operator you must turn the circuit breaker for the operator off for approximately 10 seconds, and then back on. The audible alarm will also automatically reset after 6 minutes and go back to normal operation. An exterior switch or button can also be installed on the operator to shut off the audible alarm.
- Always keep a good relationship with your technician and keep his or her number handy for future maintenance or emergencies.

EMERGENCY RELEASE PROCEDURE

SPECIFICATION:

The following procedure allows the user to release the rail from the ALL SECURE Gate operating systems drive wheels so the gate may be opened manually.

1. Remove the rear door panel of the ALL SECURE unit.
2. Release the two toggle clamps on either side of the idler wheel tower.
3. Lift up on the idler wheel and check to make sure the idler wheel turns freely.
4. Actuate the toggle latch on the right side "C" bracket to fully disengage the lower drive wheels.

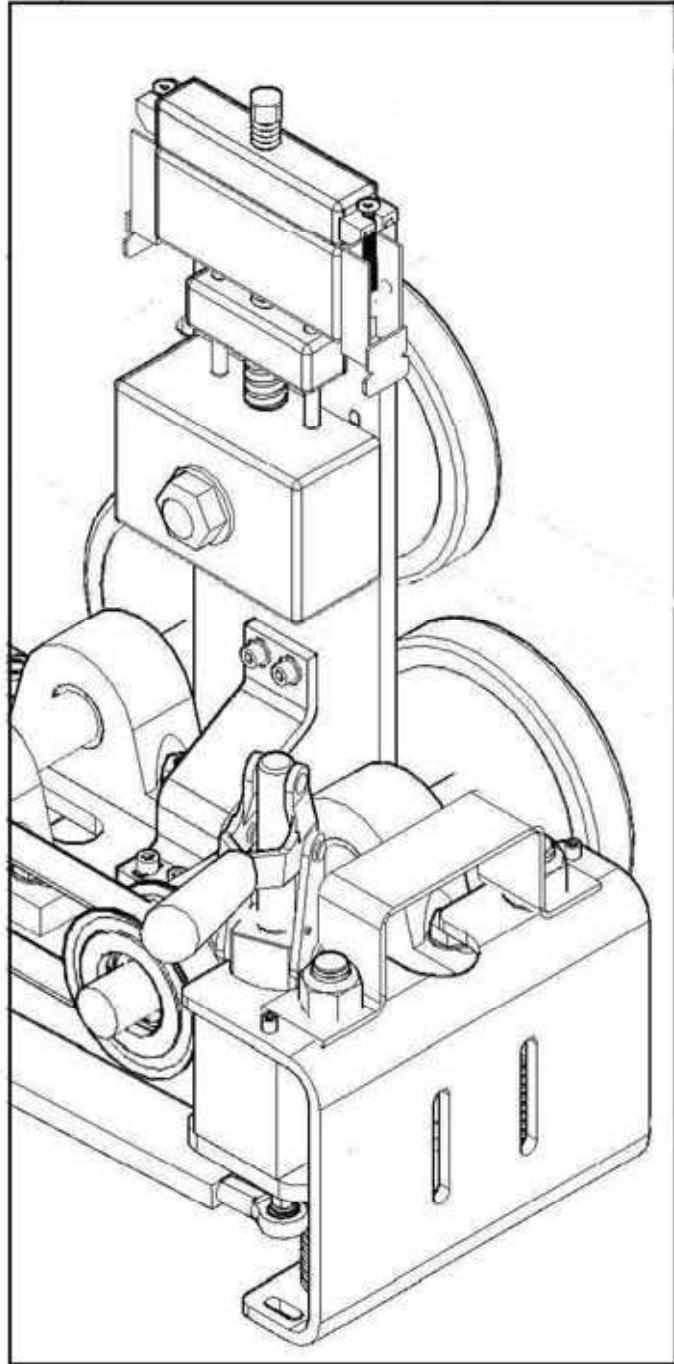

GATE ENTRANCE



1. Never let children operate or play with gate controls. Keep the controls away from children.
2. The entrance is for vehicles only. Pedestrians should use a separate entrance.
3. Always keep people, children and objects away from the gate while the gate is in operation.
No one should cross the area of a moving gate.
4. All opening devices, (such as a keypad, cardreader...), should not be installed close to the gate, where the gate could possibly cause injury.
5. Use warning signs attached on both sides of the gate.

