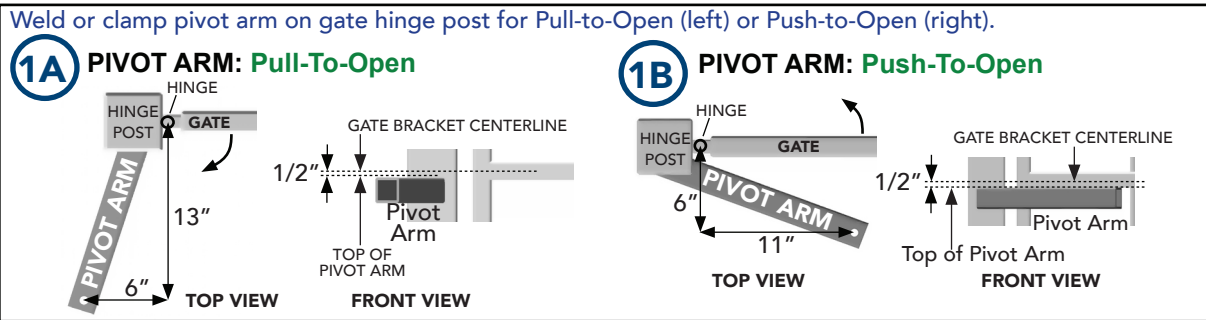
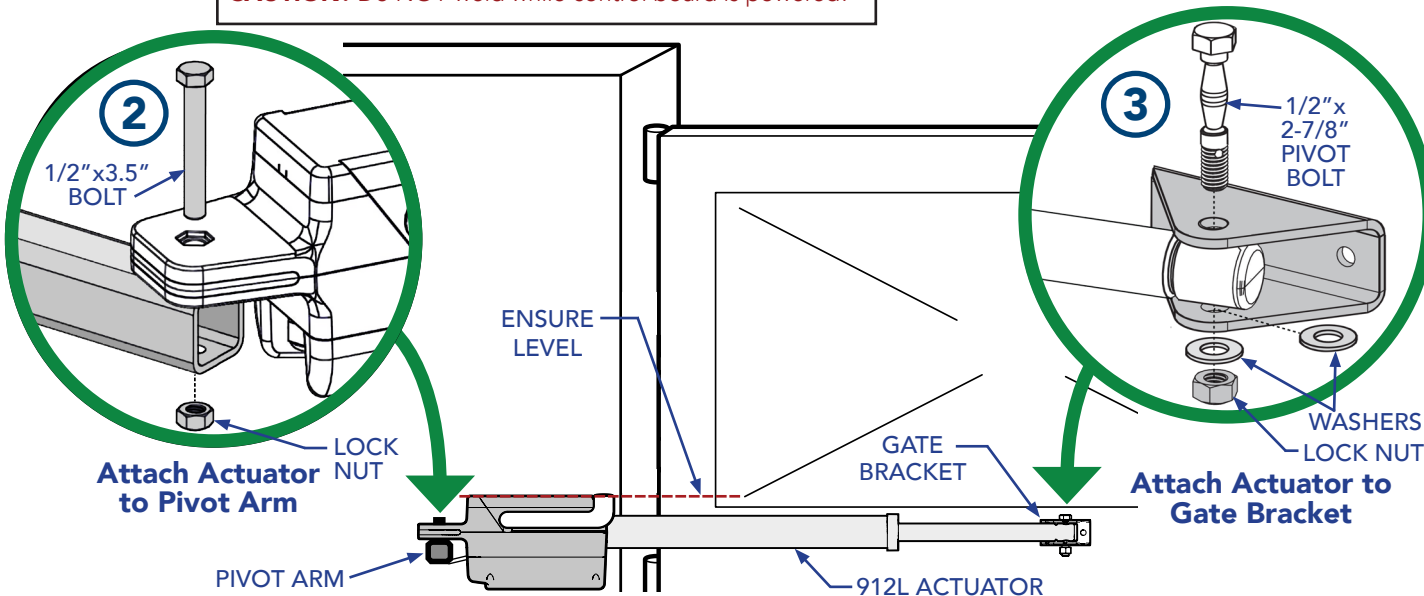


## ACTUATOR AND CONTROL BOX INSTALLATION:

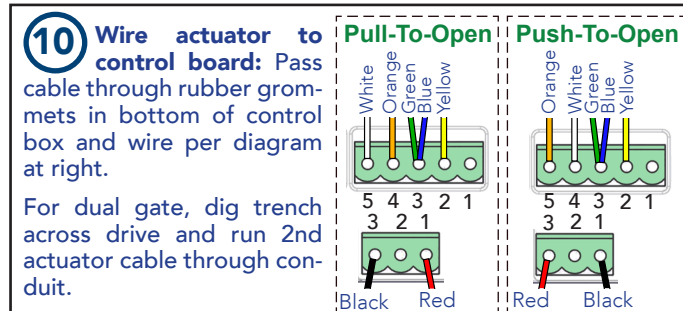
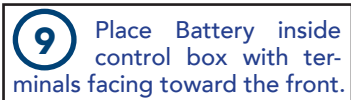
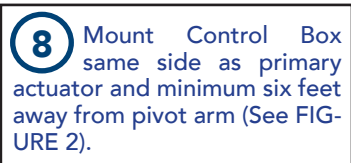
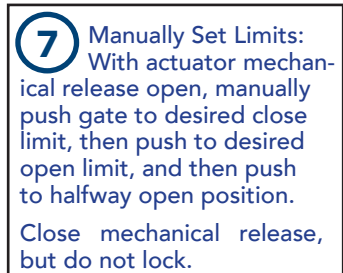
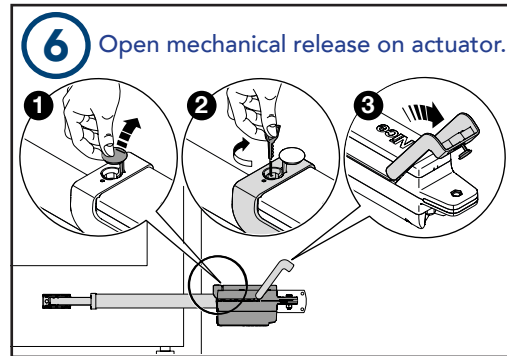
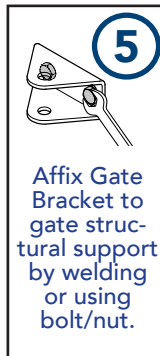
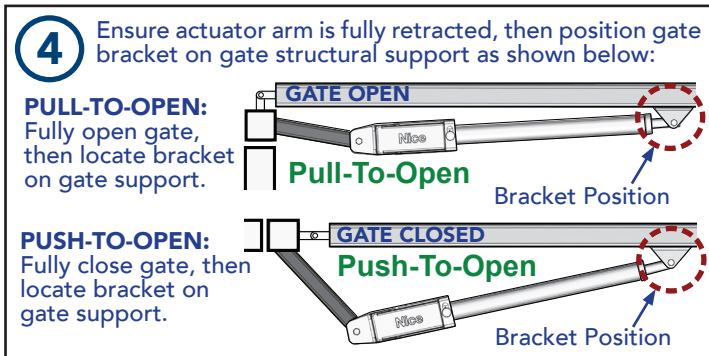
**EXTREMELY IMPORTANT!**  
Read entire manual before attempting the installation. This is NOT a "do-it-yourself" project. Use a qualified contractor to install this system. Read all safety information!



**CAUTION!** Do NOT weld while control board is powered!

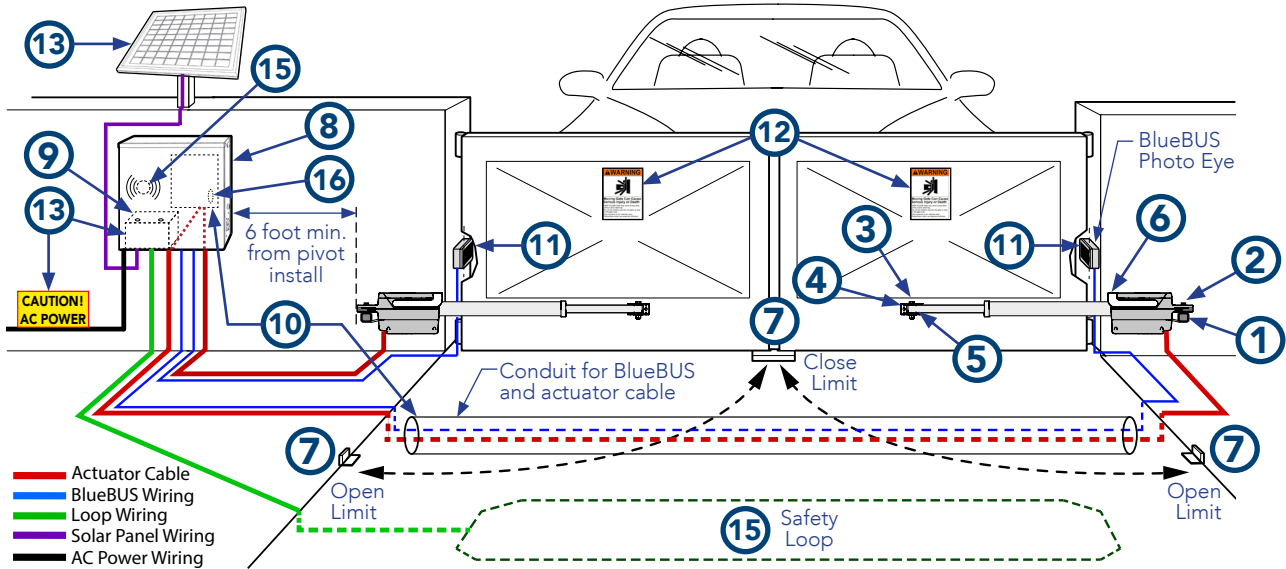


**FIGURE 1: INSTALLATION OF ACTUATOR TO PIVOT ARM AND GATE BRACKET**



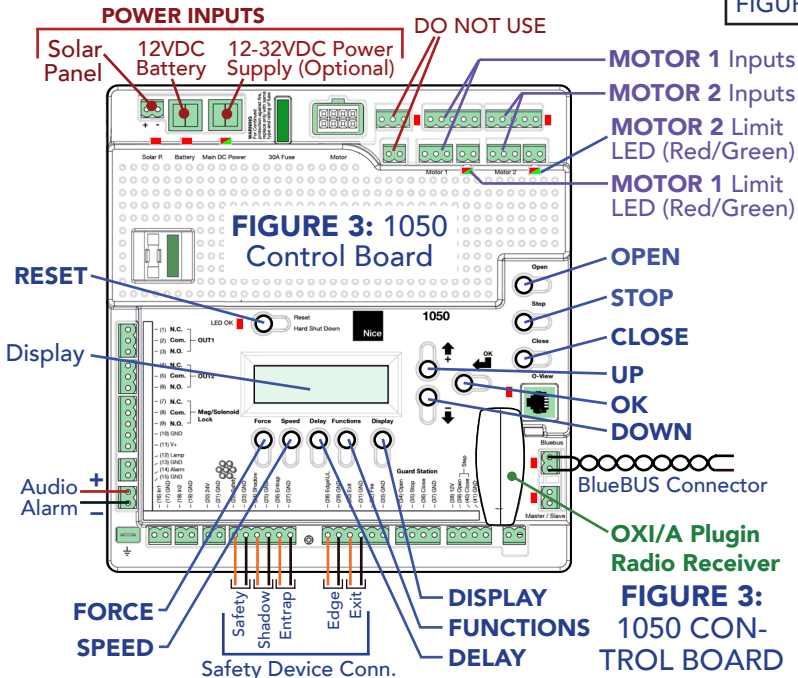
**CAUTION!** Do not mount the control box where the person using the push button on box can come in contact with the gate!

**NOTE:** Dual gate: wire Motor 1 and Motor 2 the same way.



**FIGURE 2: TYPICAL TITAN GATE SYSTEM (PULL-TO-OPEN, DUAL-GATE SHOWN)**

- 11** Determine BlueBUS photo eye locations: Install, and connect to control board, 100 feet max. See 1050 diagram below.
- 12** Attach warning signs to gate.
- 13** To power 1050 board, connect battery, optional power supply, and/or solar panels to board. See 1050 diagram below. Run AC power to AC-DC power supply, but **do NOT connect AC power directly to control board!**
- 14** Perform limit learn procedure (below).
- 15** Connect audio alarm, then connect other accessories, such as safety loops, strobes, photo eyes, or other safety devices. See FIGURE 3 below.
- 16** Program receiver and transmitters: **a)** Press/hold OXI/A RX button until green LED lights solid, then release. **b)** Within 10 seconds, press/hold any key on Nice TX until green LED blinks 3 times. **c)** Wait 15 sec. then press TX buttons to verify operation.



- GATE LIMIT LEARN PROCEDURE:**
1. **Test Gate Conditions:** Remove pivot bolt(s) and move gate to open/close positions. Check for free travel without binding, then reconnect actuator(s) to gate.
  2. **Connect power:** See INSTRUCTION 13, above.
  3. **Enter Learn Mode:** See FIGURE 4. **NOTE:** With "ENTER" flashing, "OPEN" and "CLOSE" buttons must be held down to operate. Complete Step 4 for each actuator/gate individually (disconnect actuator NOT being adjusted). Reconnect both actuators prior to Step 5.
  4. **Adjust Limit Location:** **a)** Hold down "OPEN" button until desired open position reached. If motion is opposite than desired, switch **RED** and **BLACK** wires at motor input. **b)** Adjust open limit until Limit LED glows **GREEN**. If illuminated **RED**, switch **ORANGE & WHITE** wires at terminal block. **c)** Hold down "CLOSE" button until desired close position. **d)** Adjust close limit until Motor Limit LED illuminates **RED**. **e)** Hold down "OPEN" until gate at middle of travel. If dual gate, connect both actuator cables to board.
  5. **Commence Limit Learn:** In Learn Mode (with "ENTER" still flashing) press "OK" and the following events will occur: **a)** Partial open. **b)** Slow travel in close direction. **c)** Slow travel in open direction. **d)** Full speed in close direction.
- Basic limit programming is complete. See the manual for additional programming.

