

ODC-56 SERIES

OVERHEAD DOOR CONTACT WITH FIXED MAGNET



- UL and ULC listed
- 2" operating gap
- 24" stainless steel armored cable
- Hermetically sealed reed switch

Application

The ODC-56 Series Overhead Door Contacts are exclusively designed for rugged high traffic installations. The reed switch is hermetically sealed with a PVC shock absorber enclosed within a solid aluminum housing. Installation wires are protected in a 24" stainless steel armored cable. The magnet is enclosed and protected in a heavy duty aluminum housing.

Dimensions

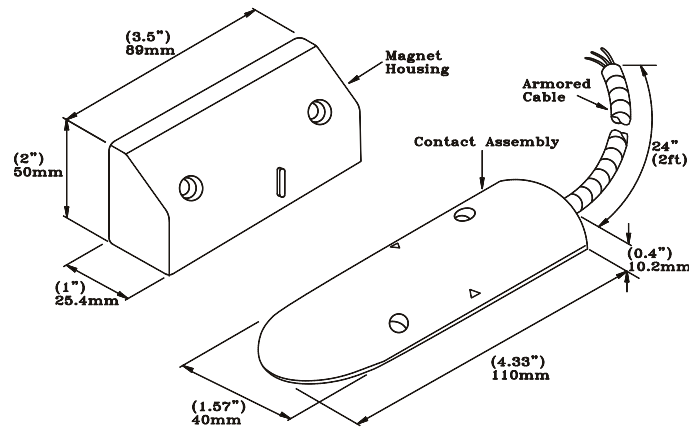

Specifications

Model	Stock Number	Contact	Contact Rating	Contact Type	Max. Carry Current	Max. Switching Current	Breakdown Voltage	Operating Gap	Temperature Range
ODC-56A	4410014	22 AWG 24" Leads	10VA	Form A N.O.	2 Amp	.5 Amp	250VDC	2"	-40°F - 257°F (-40°C - 125°C)
ODC-56B	4410015		3VA	Form C N.O./N.C.	.5 Amp	.2 amp	150VDC		