

P31086-01
GATE, INC.
STRONGARM M30
ASTM F 2656-07 M30
08 / 09 / 11
KARCO
Engineering

Strong Arm (M30)[™]

Installation Instructions

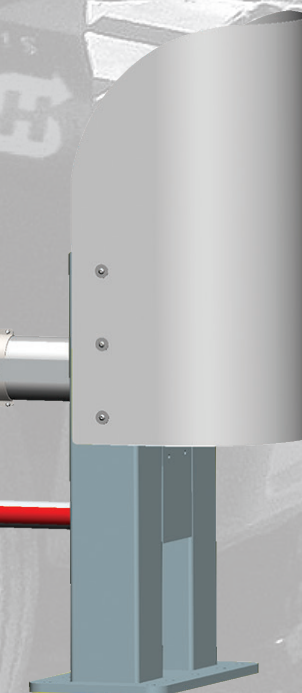

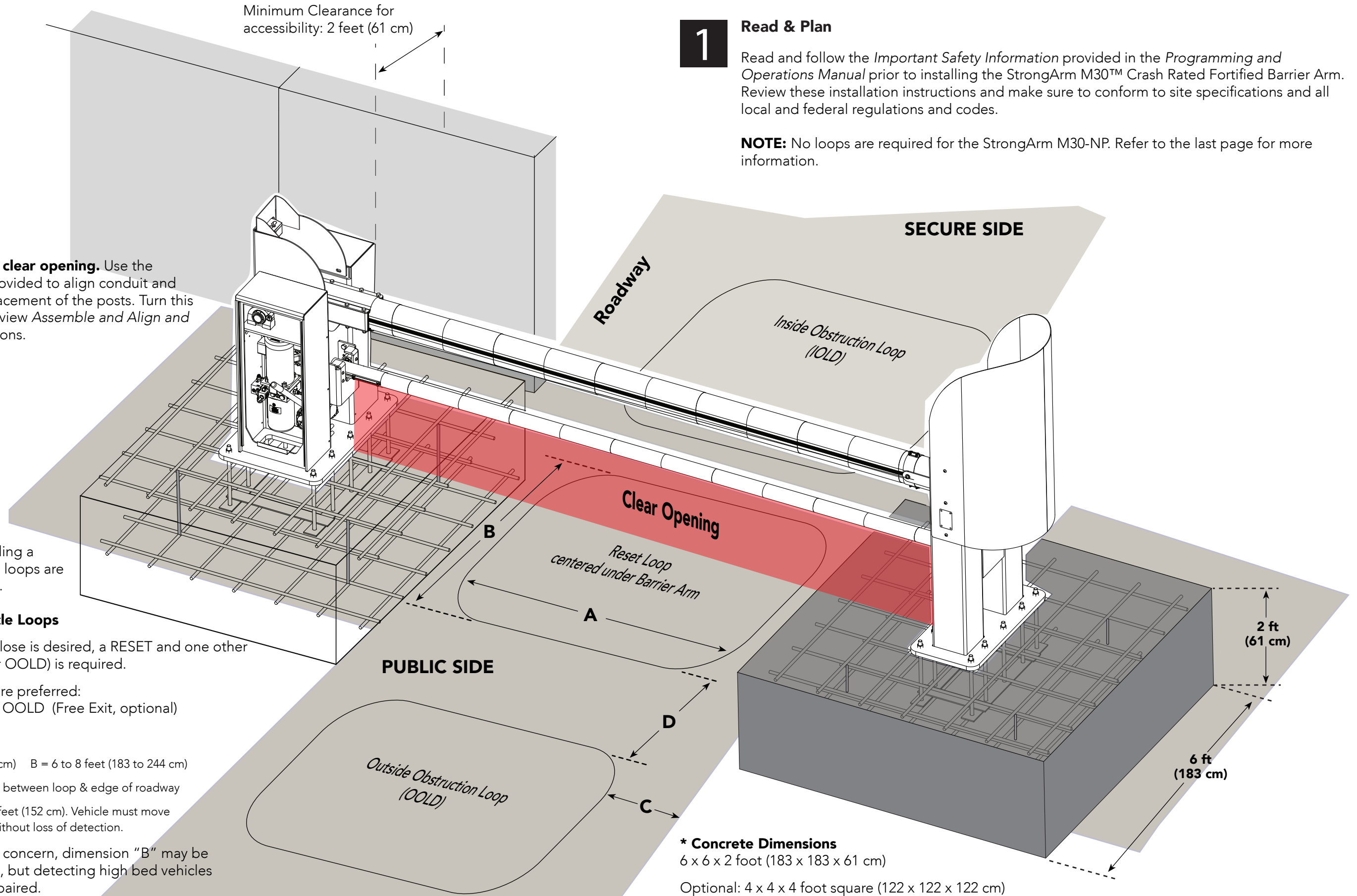

1 Read & Plan

Read and follow the *Important Safety Information* provided in the *Programming and Operations Manual* prior to installing the StrongArm M30™ Crash Rated Fortified Barrier Arm. Review these installation instructions and make sure to conform to site specifications and all local and federal regulations and codes.

NOTE: No loops are required for the StrongArm M30-NP. Refer to the last page for more information.

2 Measure the clear opening.

Use the templates provided to align conduit and determine placement of the posts. Turn this page over to view *Assemble and Align and Mark* instructions.

NOTE: If you are installing a StrongArm M30-NP, no loops are required. Ignore step 3.

3 Design Vehicle Loops

If automatic close is desired, a RESET and one other loop (IOLD or OOLD) is required.

Three loops are preferred:
RESET, IOLD, OOLD (Free Exit, optional)

Dimensions:
 A = 6 to 16 feet (183 to 488 cm) B = 6 to 8 feet (183 to 244 cm)
 C = Maintain 4 feet (122 cm) between loop & edge of roadway
 D = Maximum distance is 5 feet (152 cm). Vehicle must move from one loop to the next without loss of detection.

NOTE: If tailgating is a concern, dimension "B" may be reduced to 3 ft (91 cm), but detecting high bed vehicles will be substantially impaired.

*** Concrete Dimensions**
 6 x 6 x 2 foot (183 x 183 x 61 cm)
 Optional: 4 x 4 x 4 foot square (122 x 122 x 122 cm)

M30 Assemble & Align & Mark

TEMPLATE LAYOUT: 6 x 6 x 2 FOOT AND 4 x 4 x 4 FOOT

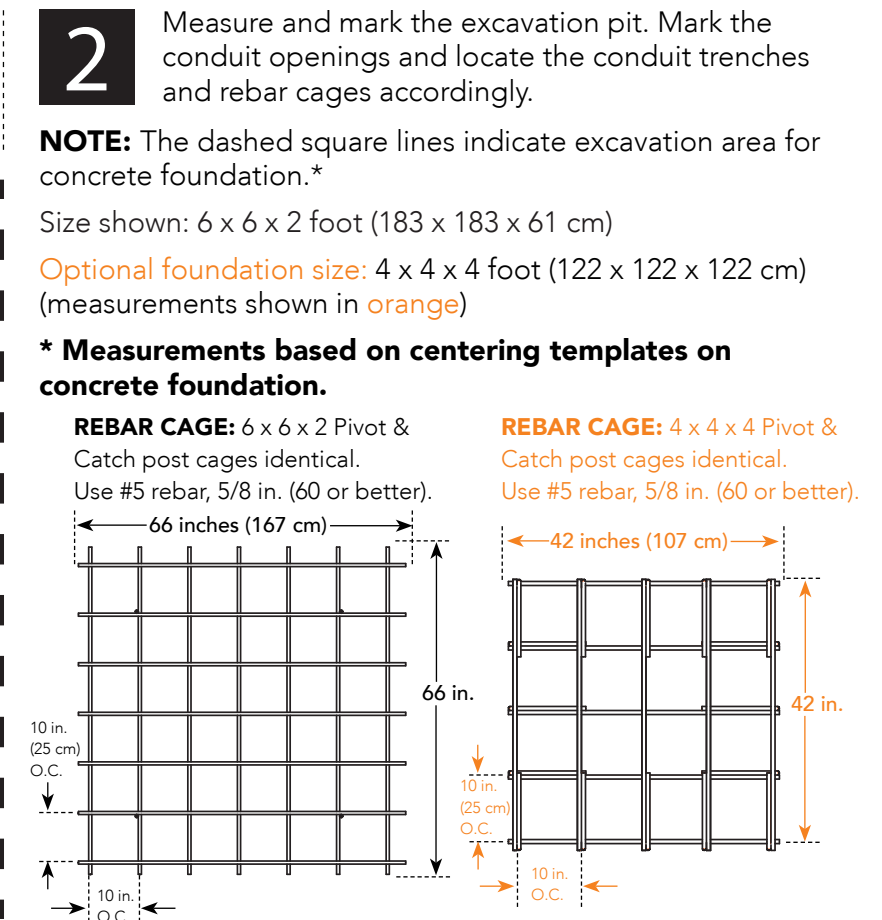
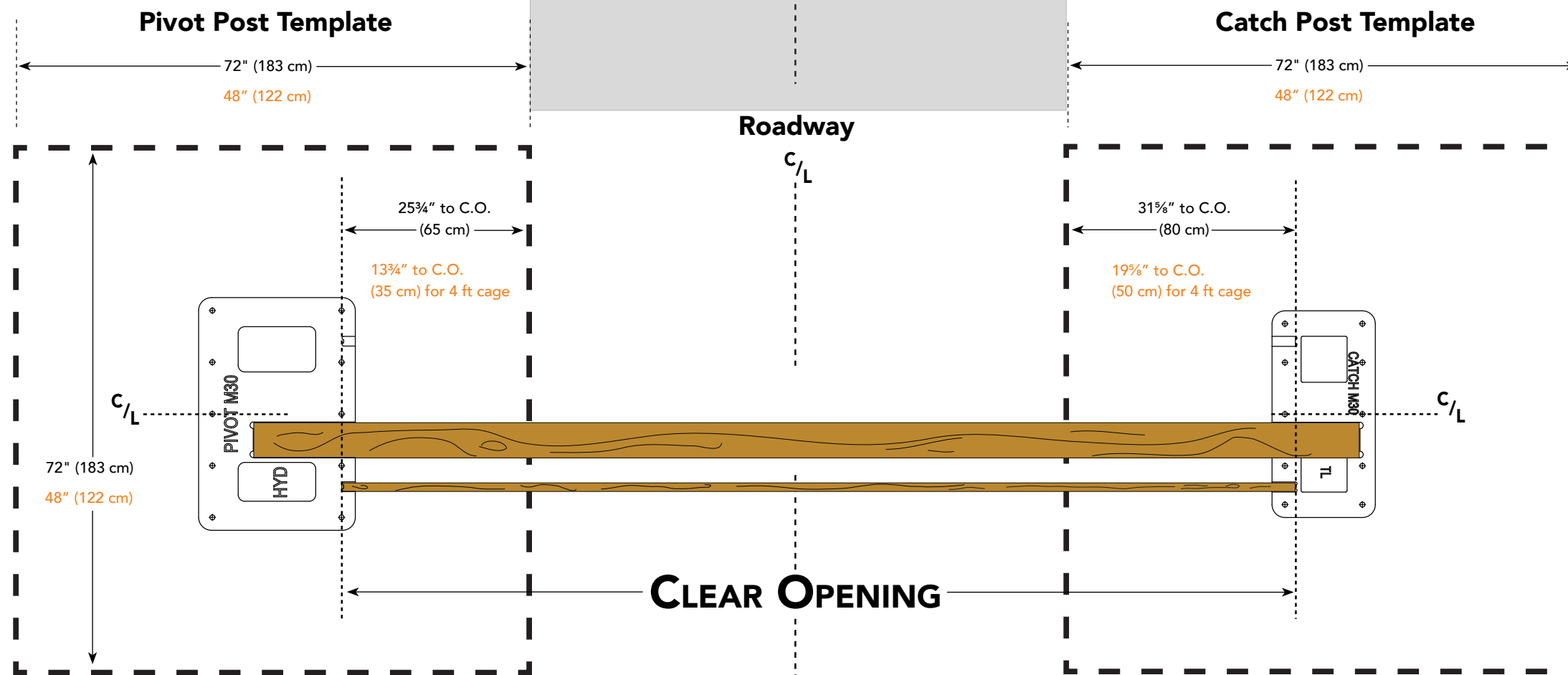
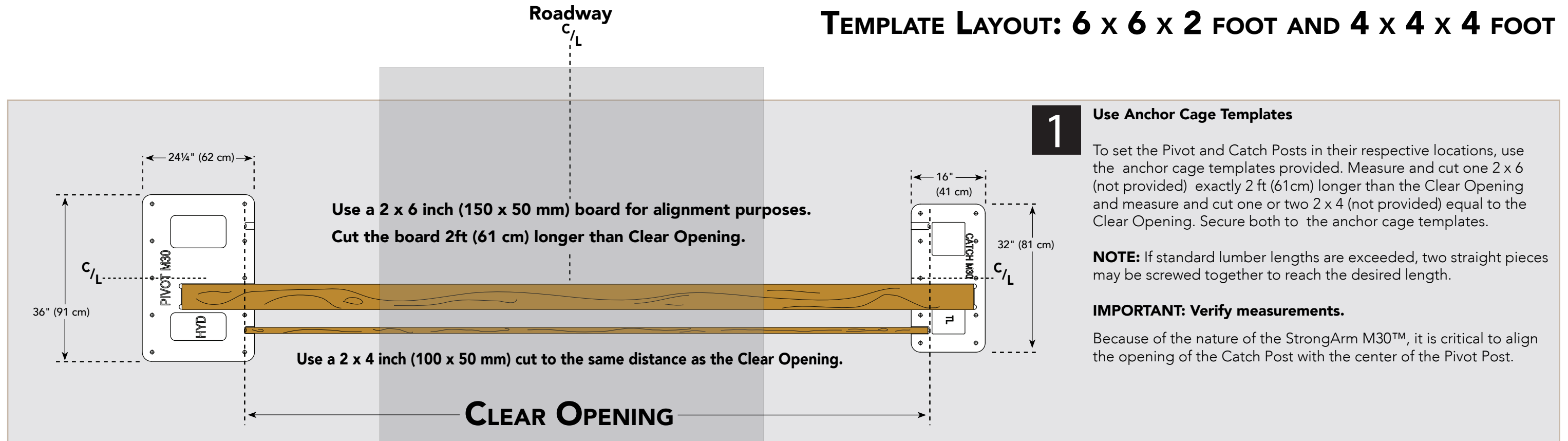

M30 Install Foundation

1 To ensure the stability of the StrongArm M30™ Crash Rated Fortified Barrier Arm, the foundation must be constructed in accordance with the following guidelines:

- Excavate a hole for the foundation to house the rebar mats and anchor bolt assemblies. Soil compression under and around the foundation shall be compacted to a soil density of 95% of standard proctor (ASTM-698). See table in Step 3.
- Add gravel where necessary to ensure a solid soil base. Soil must be stable and adequate to support the weight of the foundation.

NOTICE: Softer soils require a larger footing. Employ the services of a structural or civil engineer for site specific considerations. In Northern latitudes, consider the frost line.



Soil Density compacted to 95% per ASTM-698

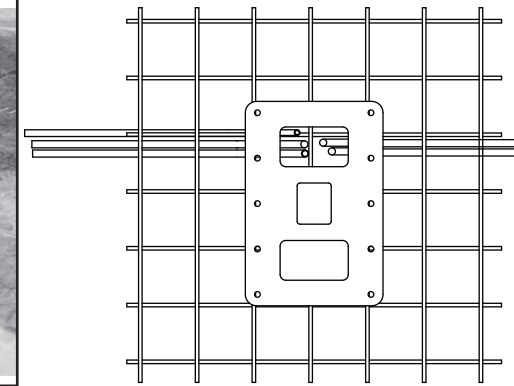

Plan View: Pivot Post Template

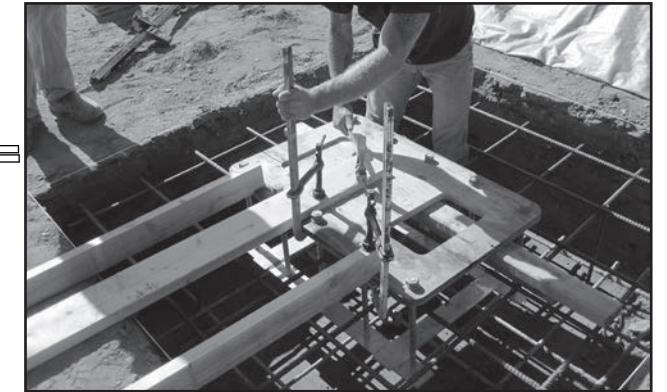

Aligning Rebar & Anchor Cage

Measure and lay conduit for communication and power: (See page 9 for M30-NP)

* **NOTE:** Catch post junction box has ½ inch opening / female thread.

2

Minimum conduit required	No.	Min. Size	cm
AC Main power	1	1 inch	2.5
Low voltage power	1	1 inch	2.5
Earth Ground	1	3/4 inch	2
Vehicle Loop wire	1 ea.	1 inch	2.5

Consider additional conduit to use for:	No.	Min. Size	cm
Dual gate systems / AC power in	1	1 inch	2.5
Dual gate systems / Low voltage power	1	1 inch	2.5
Photo eye, traffic light, Mag Lock options	1	3/4 inch	2
Catch Post Heater * (High Voltage)	1	3/4 inch	2

Lay rebar mat pattern 7 by 7 at 10-inch on center (OC). Use

5

Re-measure and adjust to correct mis-alignment issues.

7

The concrete properties must be, at minimum 3000psi. A smooth finish is required so the Pivot & Catch posts sit flat, level, & plumb.

6

Ensure anchor cage location is maintained while pouring the concrete. See Tip.

3

#5 (5/8 inch) rebar: See page 2 for grade. Purchase 10 lengths of 20 ft. (6m) for each foundation.

Foundation	Cage Rebar	Cut: #5 Rebar	Length	cm
Pivot	Horizontals	28	5½ feet	168
Pivot	Verticals	4	19 inch	48
Catch	Horizontals	28	5½ feet	168
Catch	Verticals	4	19 inch	48

4

Install the anchor bolt assemblies as shown.

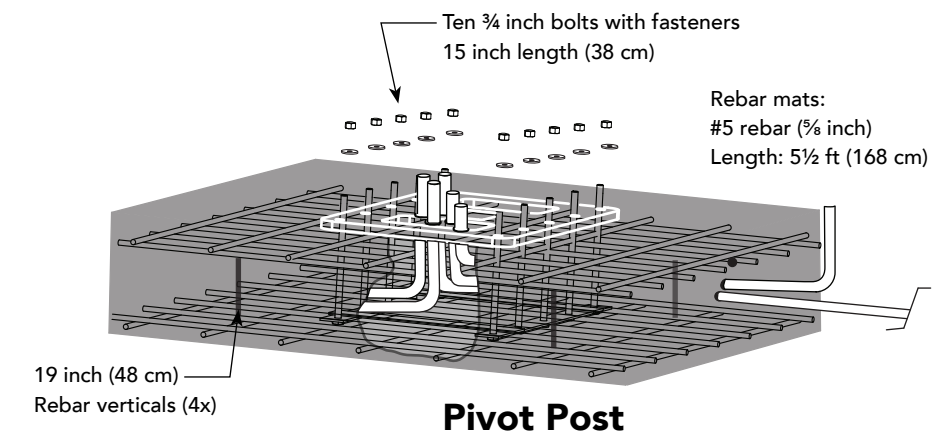
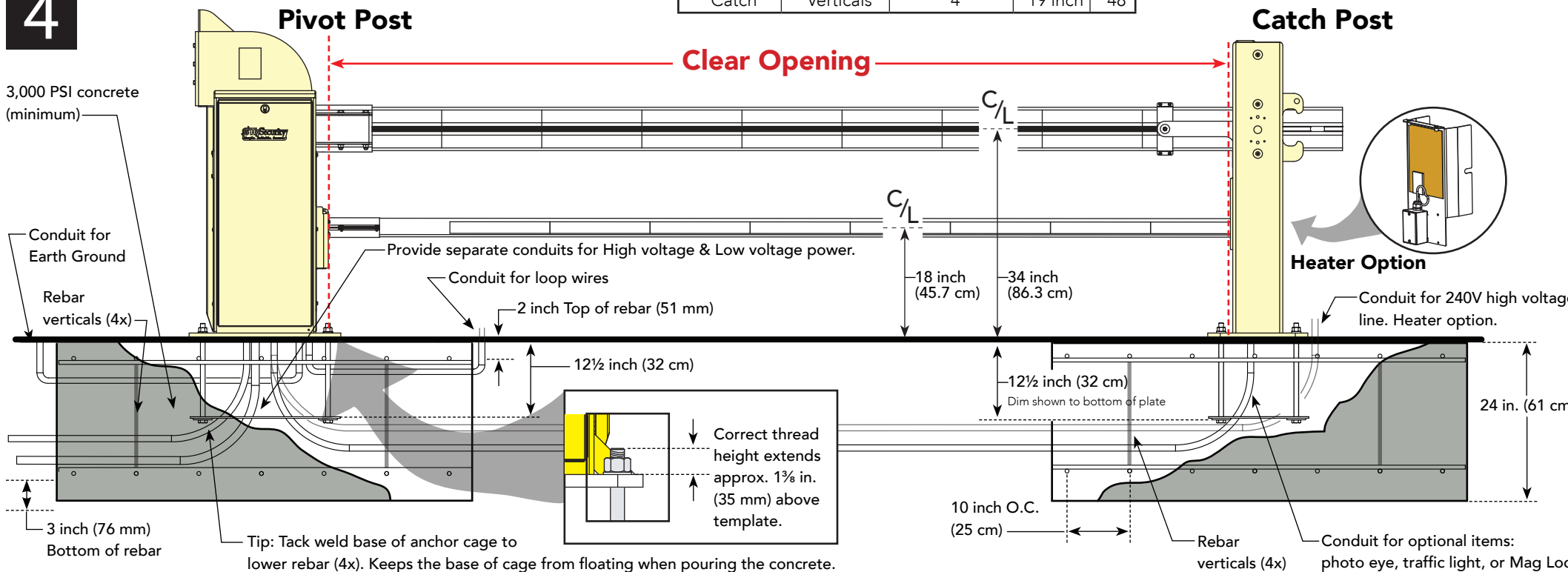

Anchor cages include 10 anchor bolts, washers, and nuts.
Foundation dimensions shown: Minimum 6 x 6 x 2 ft (183 x 183 x 61 cm)

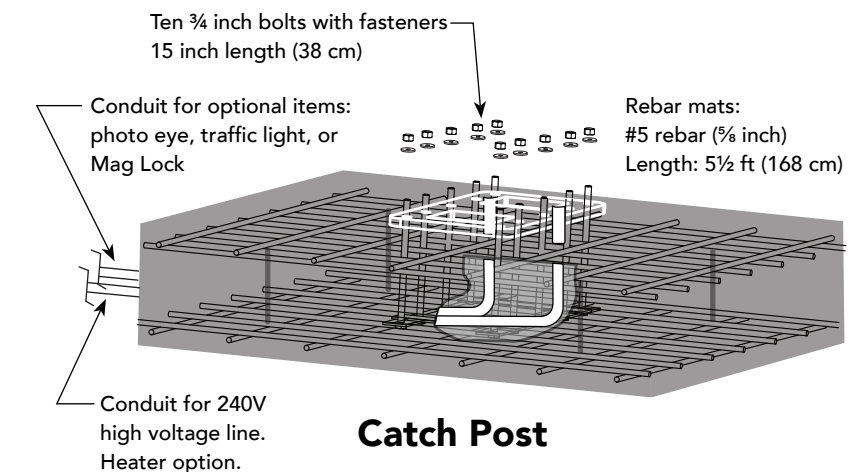

M30 Install Posts and Ground

1 When the concrete has sufficiently hardened, remove the templates.

2 Place the Pivot and Catch posts over their respective conduit and anchor bolt assemblies.

NOTE: Make sure to install the StrongArm M30 Crash Barrier Arm on a level surface. Both pivot and catch posts must be plumb, level and on grade with the roadway surface. Slope drainage 1/4-inch per foot within 2 feet of the operator (2 cm per meter).

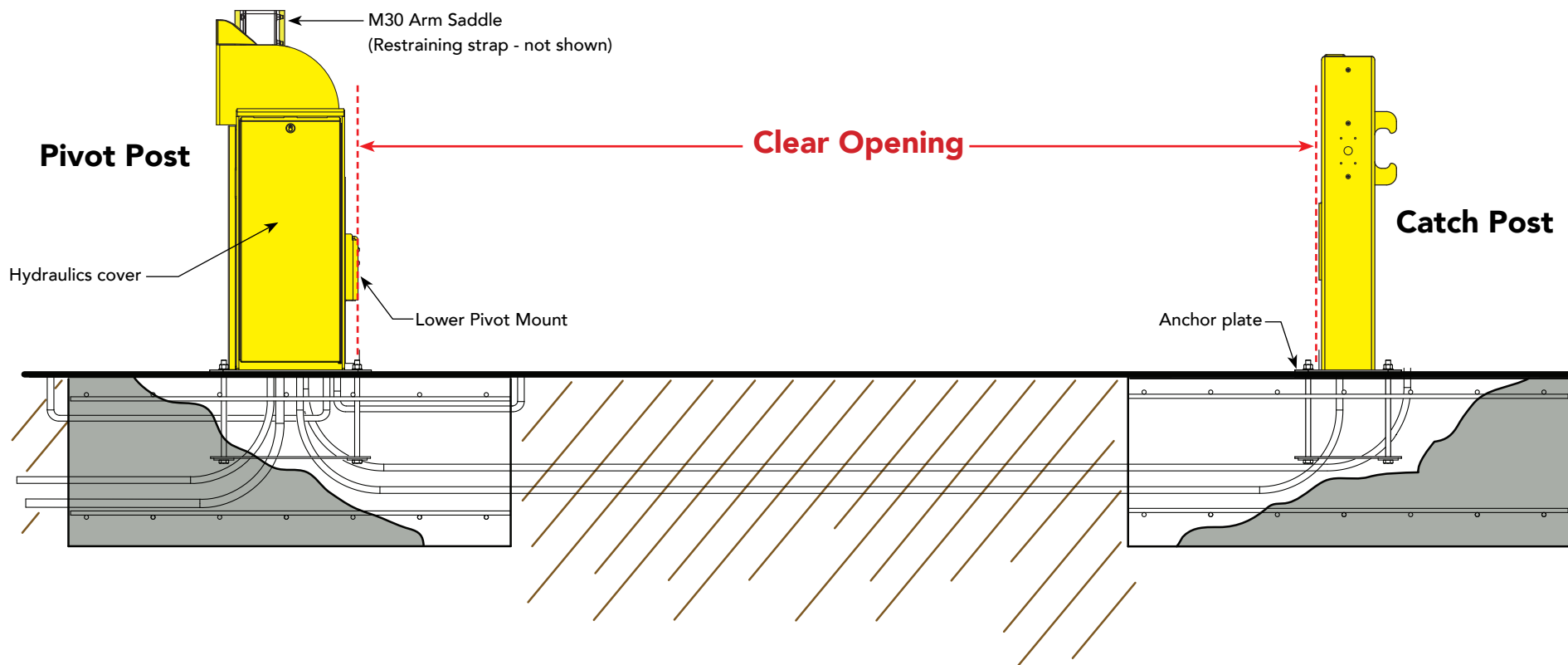

3 Ensure the posts are plumb. Shim or grout as required.

4 To secure each anchor plate with the ten washers and nuts provided for each post, use a 1 1/4-inch socket and torque wrench. Torque to 200 ft · lb (271 N·m)

5 Install the grounding rod per local building codes.

6 Attach a large earth ground wire (6AWG) from the grounding rod to the lug nut on the chassis. Feed the 6AWG wire from the chassis to the earth ground rod.

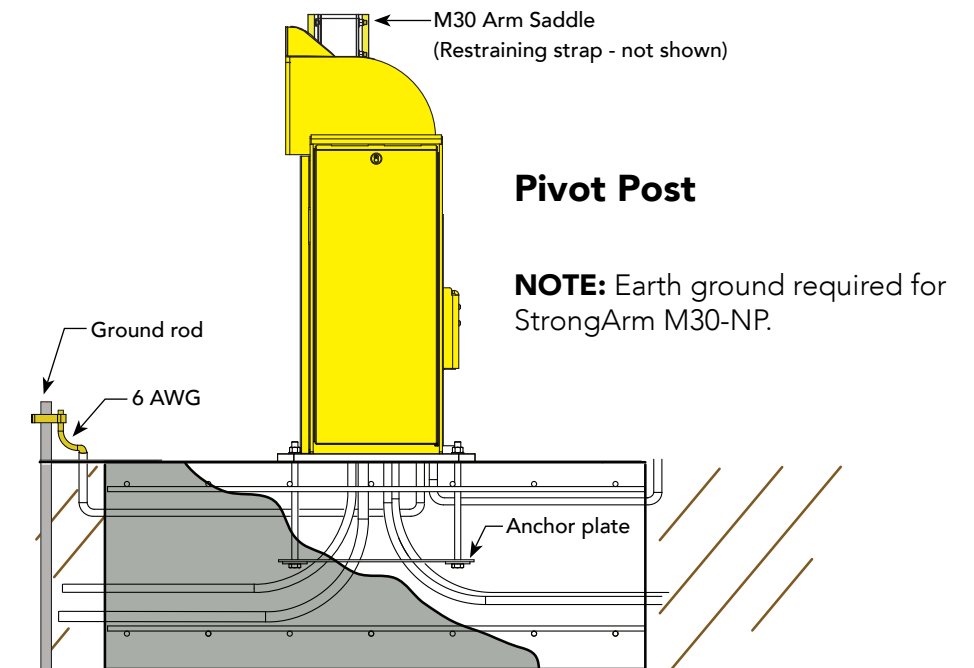

! DANGER

The potential for lightning discharge exists with all gates, barrier arms, fences, and gate operators. National Electric Code (NEC) requires a separate earth ground in addition to the required equipment ground.

For earth grounding requirements in the U.S.A., refer to the National Fire Protection Association (NFPA) 780 - Standard for the Installation of Lightning Protection Systems.

Highlights of the standard include:

- The ground rod must be UL listed copper-clad steel, solid copper, hot-dipped galvanized steel, or stainless steel. Minimum requirements: 1/2 inch (13 mm) diameter and 8 feet (244 cm) in length.
- The ground rod is driven into the earth (refer to local codes for proper depth requirements).
- The ground rod is electrically bonded to the chassis with a single length of un-spliced 6AWG copper wire less than 3 feet (91cm) long. Due to the large concrete foundation, make the necessary adjustments to accommodate for earth ground requirements.
- Local jurisdictions may impose additional or different requirements above the NEC and NFPA 780. Consult the local codes and regulations regarding requirements in your area.

NOTICE: Properly grounding the gate operator is critical to gate operator performance and personnel safety. Equipment containing electronics may benefit when the earth ground discharges excessive voltage. Use sufficient wire size during installation. If you do not ground the operator with a separate earth ground rod, you risk voiding the Limited Warranty.

M30 Assemble Barrier Arms

1 Mount the Lower Pivot Assembly (comprised of the lower arm and bearings) into the Pivot Post enclosure and secure the bearings to the Lower Pivot Mount with the four buttonhead screws.

CAUTION
Prevent potential injury! Remove the Lower Catch Pin BEFORE installing the Lower Arm. If it is not removed, it may slide out of the Lower Arm during installation and drop onto personnel or equipment.

Pivot Post

Restraining strap not shown

Hand pump

Lower pivot assembly
Bearings

Loosen and remove the four button head screws from the bearings prior to installing the lower arm.
Tool: 7/32-inch Hex key

Lower pivot mount

M30 Arm Saddle

2 Rest the Lower Arm on the Catch Post, and then use the manual pump handle to lower the M30 Arm saddle into a horizontal position.

NOTE: StrongArmM30-NP (no power) operation is shown on page 9.

CLOSE Arm

1. Seat and lock handle into base.
2. Pump handle until arm is horizontal and level.

Manual Operation

OPEN Arm

1. Seat and lock handle into base.
2. Open valve. Pull out (1) and twist (2). Release.
3. Pump handle until arm opens fully.
4. Close valve. Pull out (1) and twist (2). Release and reseat valve.

NOTE: Make sure valve does not reseat itself.

3 Loosen, but DO NOT remove, the six bolts and nuts on the Lower Pivot Assembly.
Tools: 7/16-inch wrench plus 7/16-inch socket wrench

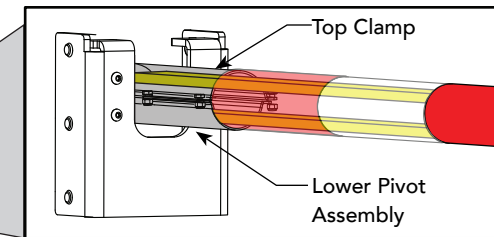

4 Slide the Lower Arm to obtain 3/4-inch clearance at the Catch Post.

Lower Catch Pin

3/4-in. (2 cm) gap

3/4-in. (2 cm) gap

5

With the gap clearance set at approximately 3/4-inches between the Lower Catch Pin and Post, securely tighten the top clamp (see step 3) on the Lower Pivot Assembly.

Bumper for M30 Arm

**Overhead View
Lower Catch Pin**

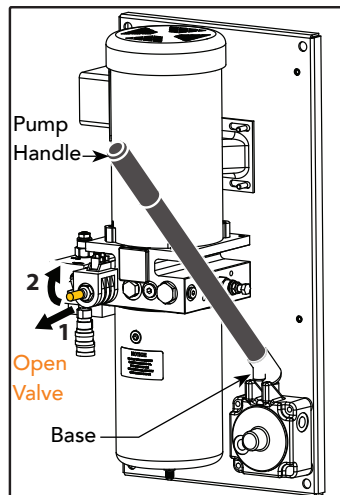

Install M30 Arm

1 Loosen and remove the ten top clamp fasteners from the M30 Arm Saddle and set the top clamp and nine fasteners aside.

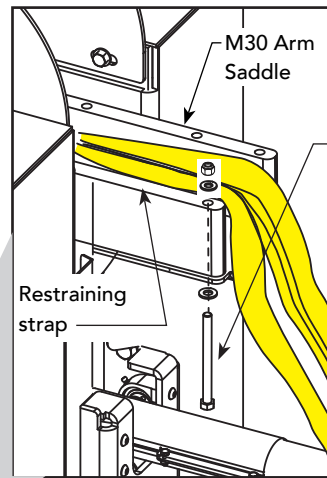
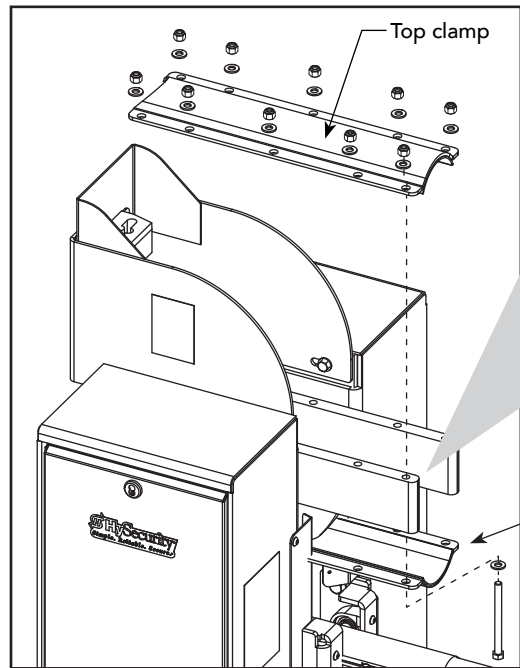

2 To stabilize the bottom clamp, return one fastener to the front edge of the saddle. Keep the nut loose while installing the straps and aligning the upper catch pin.

Tools:
¾-inch box-end wrench
½-inch drive ratchet with 12-inch extension and ¾-inch socket

Bottom Clamp
For clarity: Restraining strap and nine bolts /washers are not shown.

3 The M30 Arm is very heavy. Use proper lifting techniques and obtain assistance to install the M30 Arm.

Rest the M30 Arm on the Catch Post's bumper to support its weight while you and your assistants feed the restraining strap through the M30 Arm.

NOTE: Feed both sets of the LED Arm Lights over the upper pivot pin. (LED lights do not come with the M30-NP operator.)

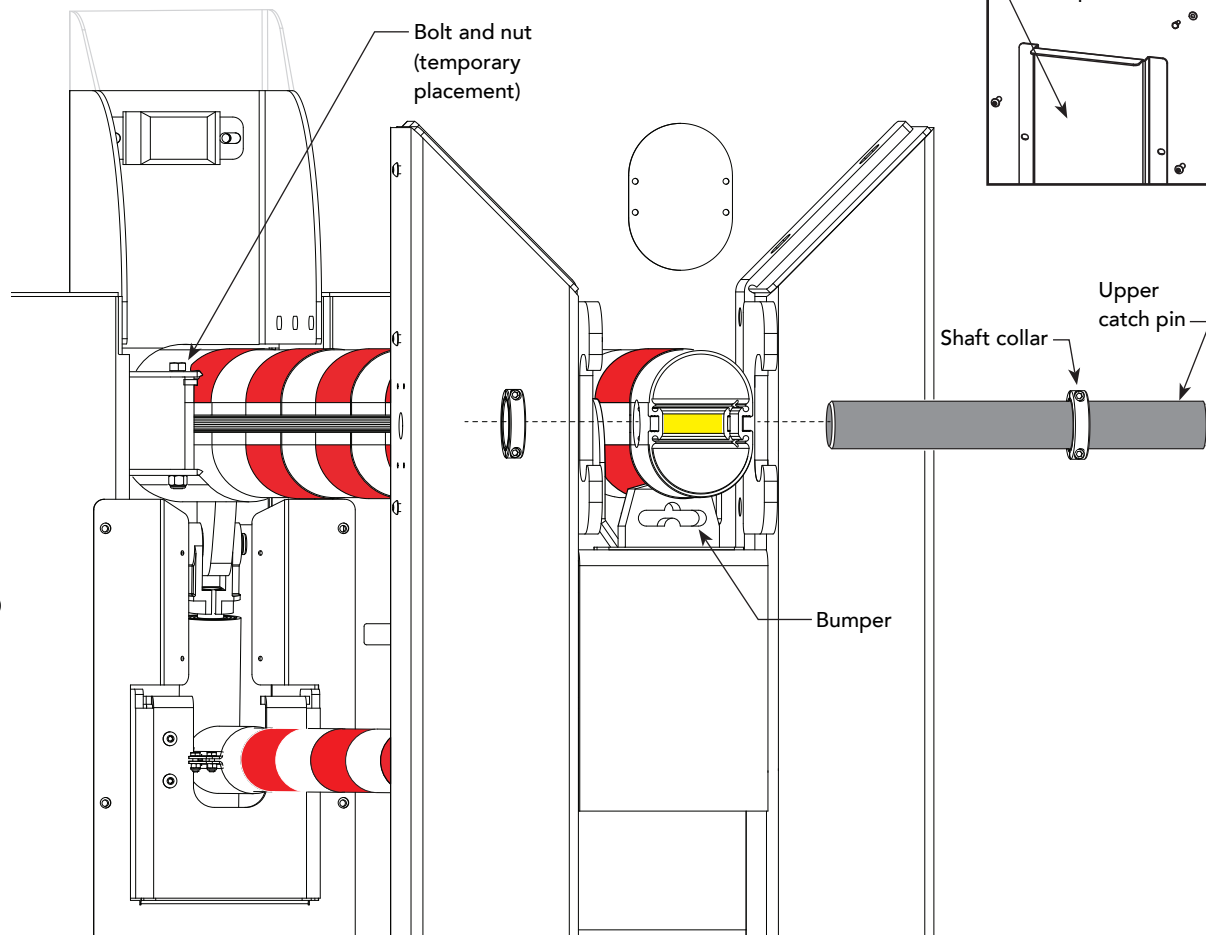

4

Remove the side panels, rear panel and end cap.
Tools: 7/16-inch socket wrench

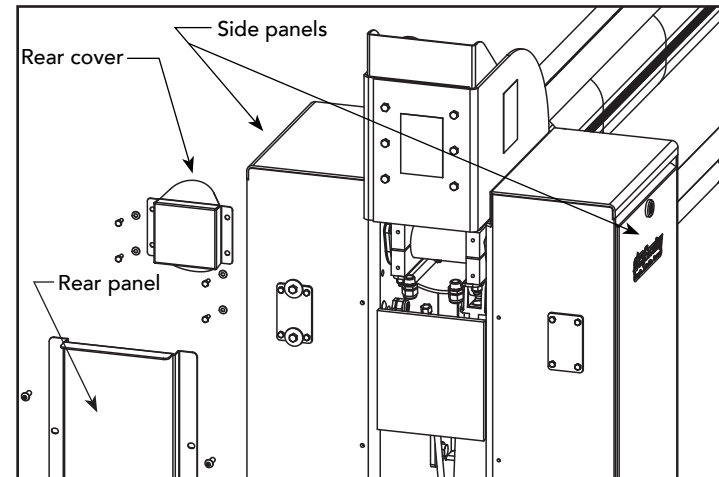

5

As you slide the Upper Catch Pin through the end of the M30 Arm, place both of the strap loops around the Upper Catch Pin.

Tip: For leverage, stretch the strap using a 2 x 4 (100 x 150).

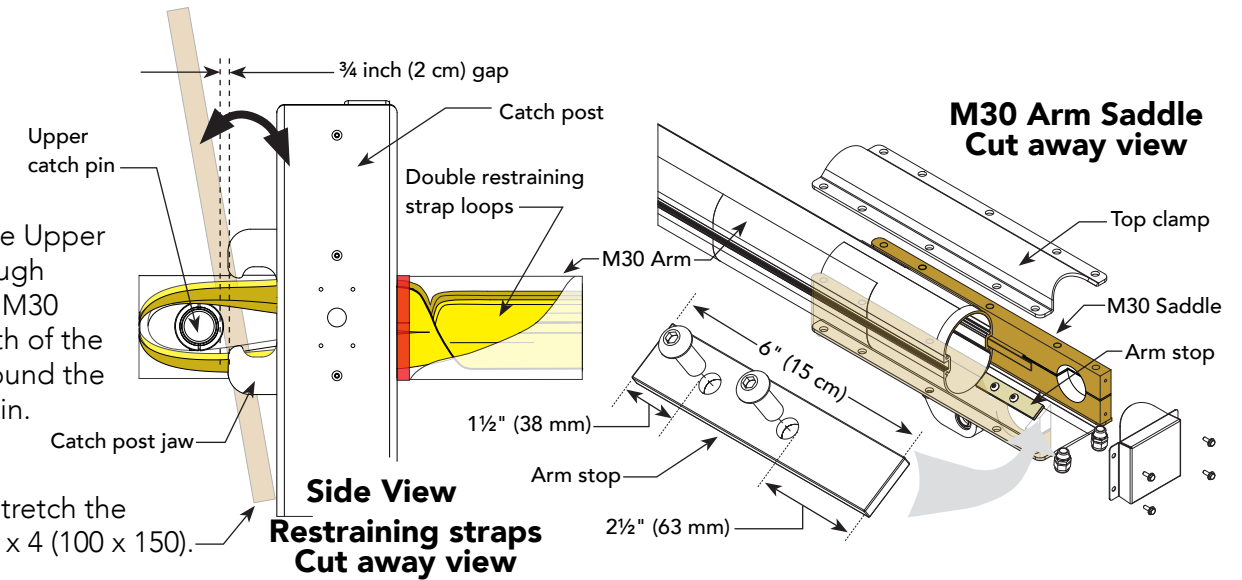

- Position arm in M30 Saddle.
- ★ → • **Set ¾" gap between shaft collar and catch post jaw.**
- Adjust arm stop.
If the M30 arm does not butt up against the edge of the arm stop:
 - ♦ Remove the arm stop
 - ♦ Flip it, if needed
 - ♦ Cut to measure
 - ♦ Re-install it to prevent M30 arm slippage.

Tools: 7/32-inch Hex key

7

Position the End Cap and secure it using four hex head screws.
Tool: ½-inch socket extension

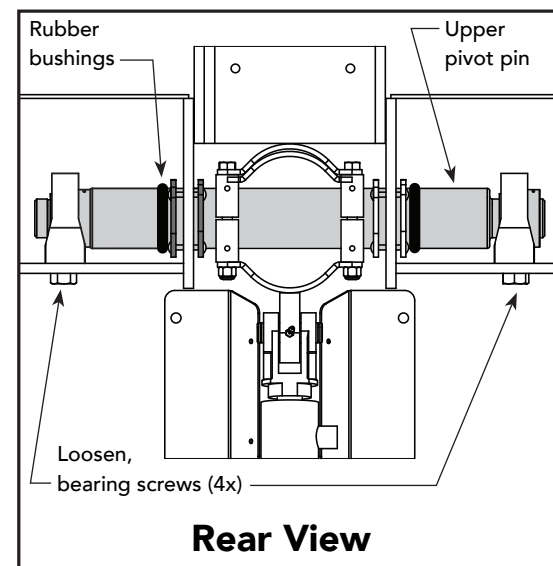

6

Adjust the Shaft Collars to hold the pin in place and tighten the set screws securely.

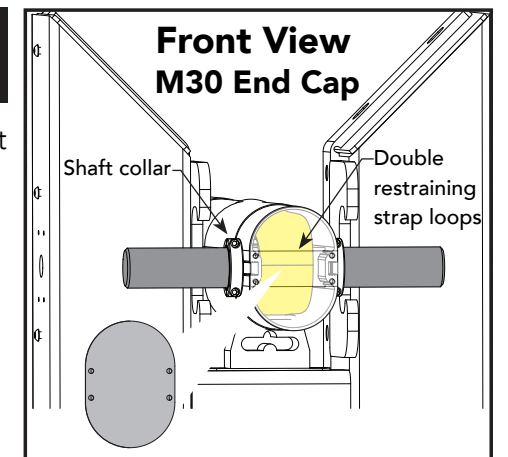

8

Loosen, but do not remove, the 4 bearing screws.
Center the upper arm between the catch posts.
With upper arm centered and aligned, tighten bearing screws (4x).

Torque to 150 ft·lb (203 N·m).

M30 Link Arms & Install Light

1 With arm aligned in the saddle, make sure the two LED Arm Lights cable are routed over the pivot pin, and then secure the Top Clamp with 10 bolts and fasteners.

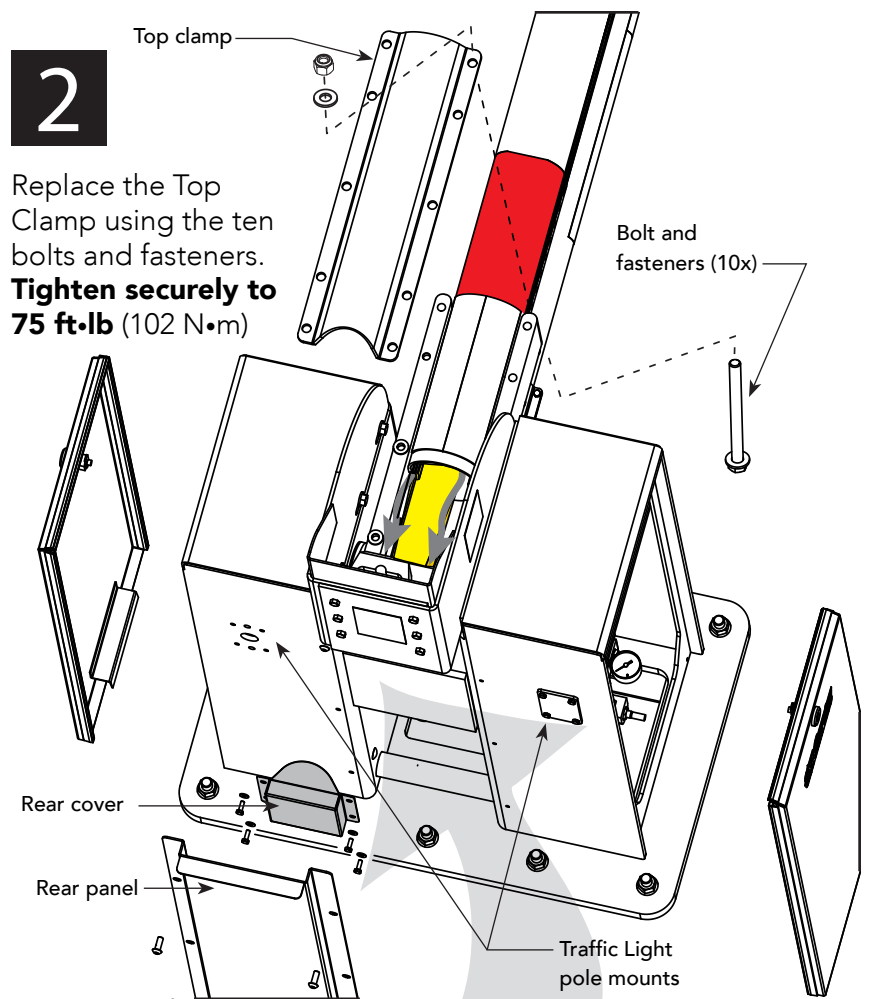

2 Replace the Top Clamp using the ten bolts and fasteners. **Tighten securely to 75 ft·lb (102 N·m)**

CAUTION
To preserve LED Arm Lights cable integrity and allow for arm movement, maintain a minimum length of 12 inches (30 cm) between the strain reliefs. If the cable loops are not maintained, you risk damaging the cables and voiding the Limited Warranty.

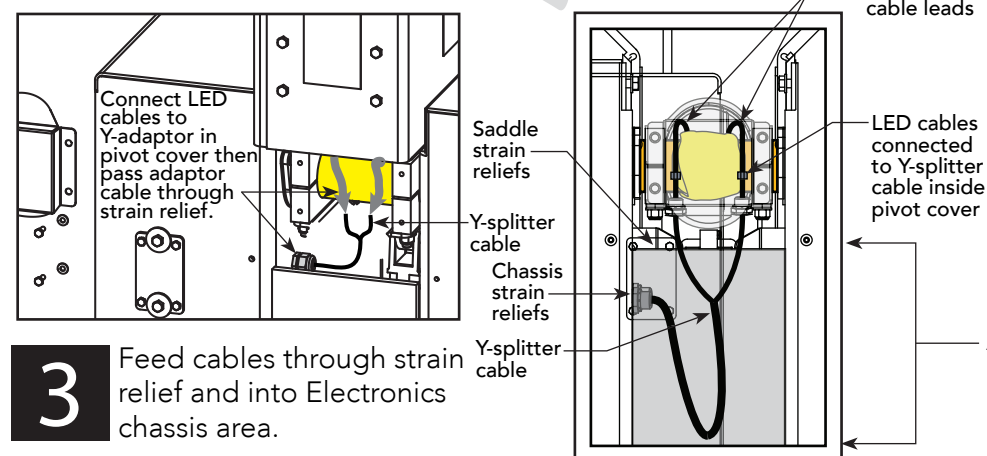

3 Feed cables through strain relief and into Electronics chassis area.

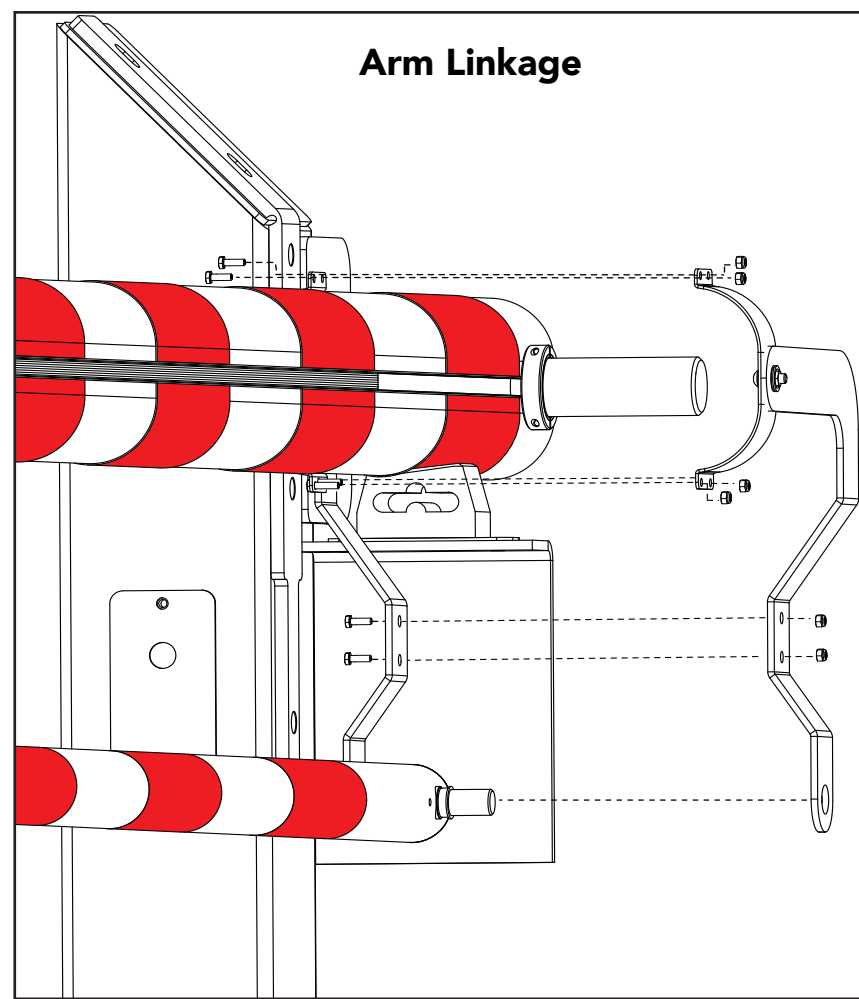

4 Assemble the Arm Linkage as shown in the illustration. Tighten the fasteners securely.
Tools: Two 7/16-inch box end wrenches and two 9/16-inch socket wrenches.

Tip: Ask an assistant to manually raise the M30 Arm so it clears the Catch Post and provides easier access to the Arm Linkage fasteners.

Allow cable slack for arm movement. Provide for a minimum of 12 inches (30 cm) between saddle and chassis strain reliefs.

5 Assemble the Traffic Light per the illustrations. Two different pole mounts exist.

Tools: 7/16, 1/2, 9/16 - inch socket wrenches. Large groove joint pliers

NOTE: Additional Traffic Lights are available and can be mounted to the Pivot Post or Catch Post. (Not available on M30/M50-NP.)

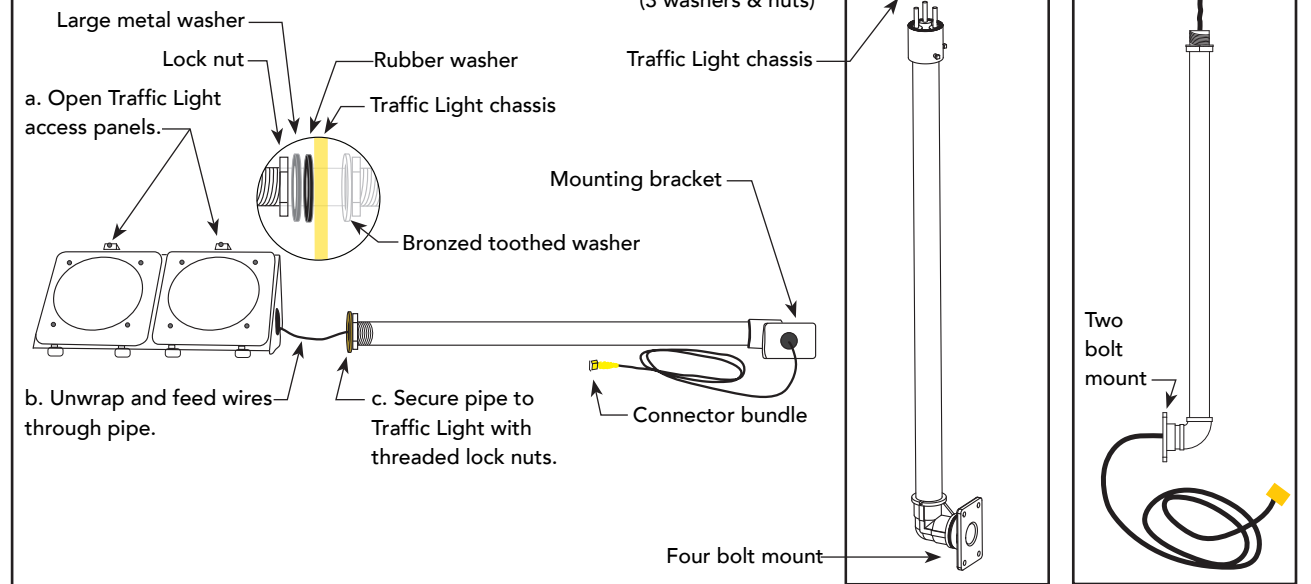

Pivot Post w/ Traffic Light

Arm lights flash when opening and closing. Default setting: **User Menu: AL 1** Arm Lights flash whenever the Close Limit is encountered. Changing to AL 0 causes arm lights to be continuously lit when the Close Limit is encountered.

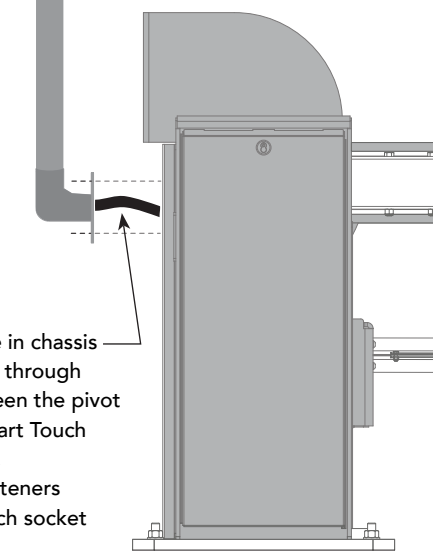

Connecting Traffic Lights & STC Settings

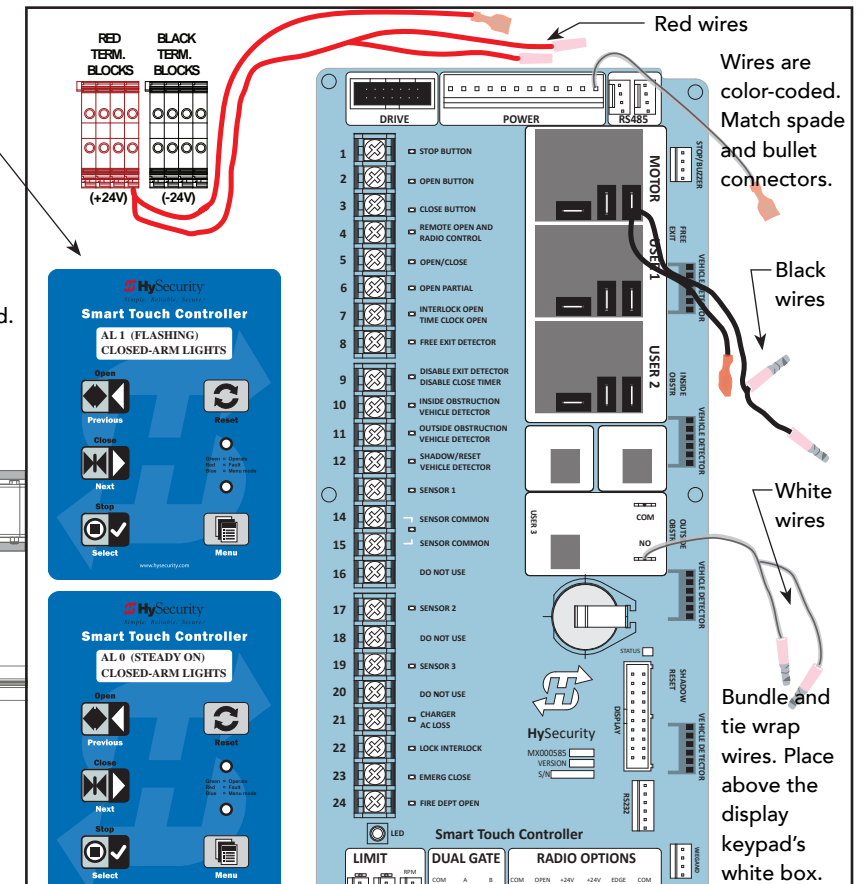

M30 Complete the Installation

! DANGER

Turn OFF AC power at the source (circuit breaker panel) before accessing the wires in the StrongArm M30 junction box. Follow facility Lock Out/Tag Out procedures. Make sure all power switches are in the OFF position. Follow all electrical code standards and regulations.

1 Prep for Power: Three wires and a ground are available for connection to a 3 Phase power source (3Ø). Loosen the screws on the power module to open the wire slots at the top and bottom.

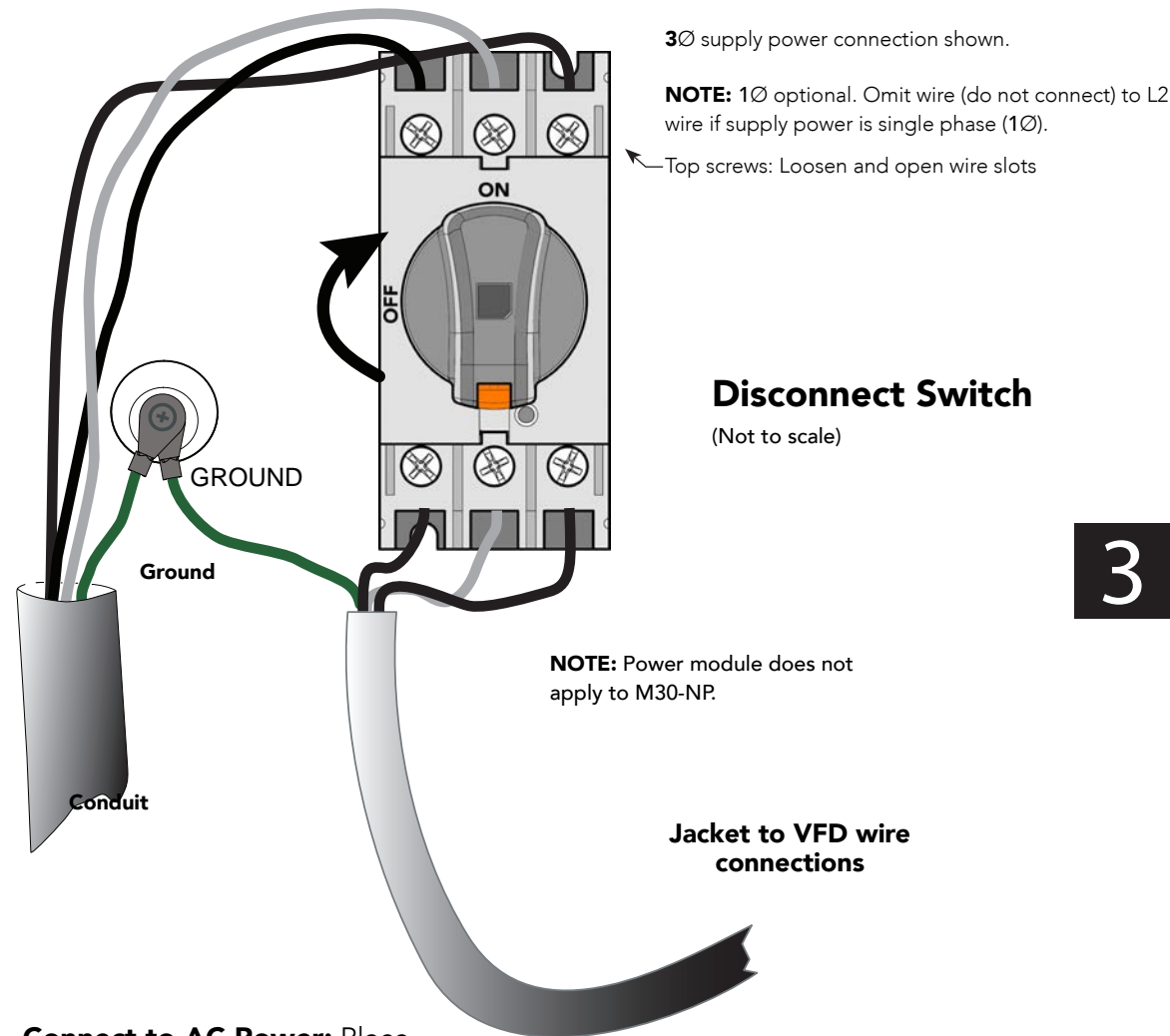

2 Connect to AC Power: Place the incoming power wires into their appropriate slots. Attach the ground wires to the chassis.

NOTE: Wiring of gate operators must conform to NEC standards and comply with all local codes. When the installation is compliant and complete, turn on AC power at the source and power module.

4 Remove the Vent Plug.

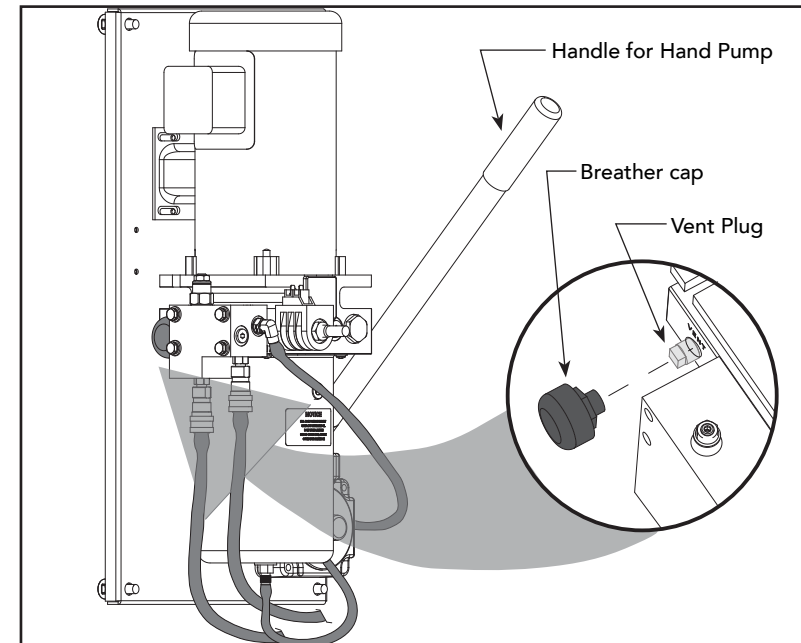

AC powered M30 Gate Operator

5 Replace it with the Breather Cap.

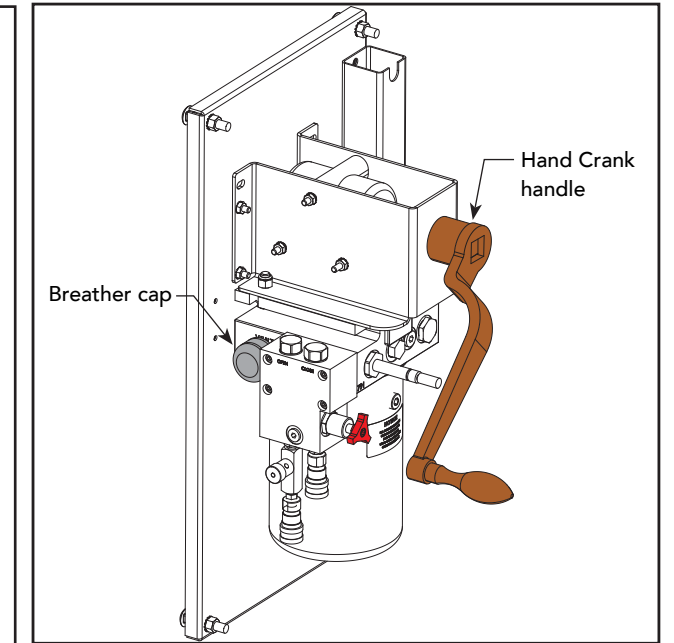

M30-NP (non-powered) Gate Operator

3 Install entrapment shield: Remove the six hex head screws and fender washers from the Catch posts and use them to secure the Entrapment Shield as shown. (Entrapment shield is optional on the M30-NP.)

Tighten all six screws using a 7/32 hex key.

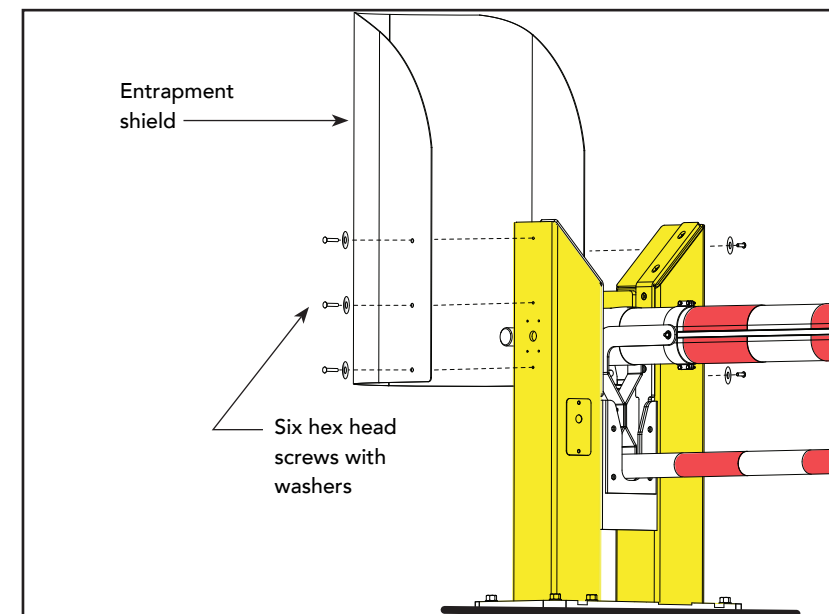

Torque Requirements:

Bolt Size (inches)	ft·lb	N·m
¼ - 20	10	13
⅜ - 16	28	38
½ - 13	75	102
⅝ - 11 & ⅝ - 18	150	203
¾ - 10	200	271

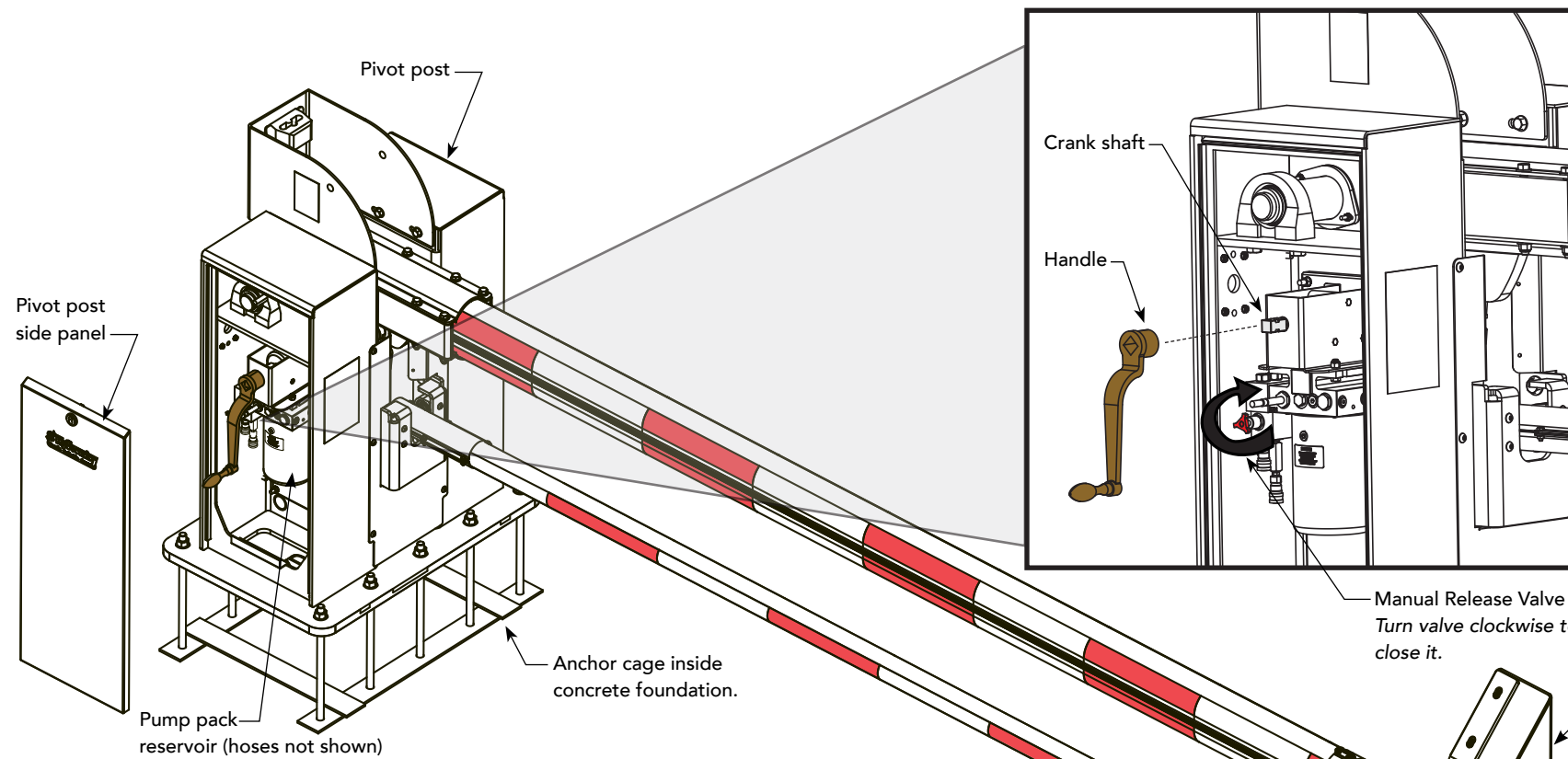

1 PREP FOR HAND CRANKING:

Close the Manual Release Valve by turning its red knob **clockwise** until it stops (about two turns). **Do NOT** use excessive force once the knob stops turning.

Place the handle onto the crank shaft. (Or, fit a high torque cordless drill with a 1-inch, 12-point socket onto the crank shaft.)

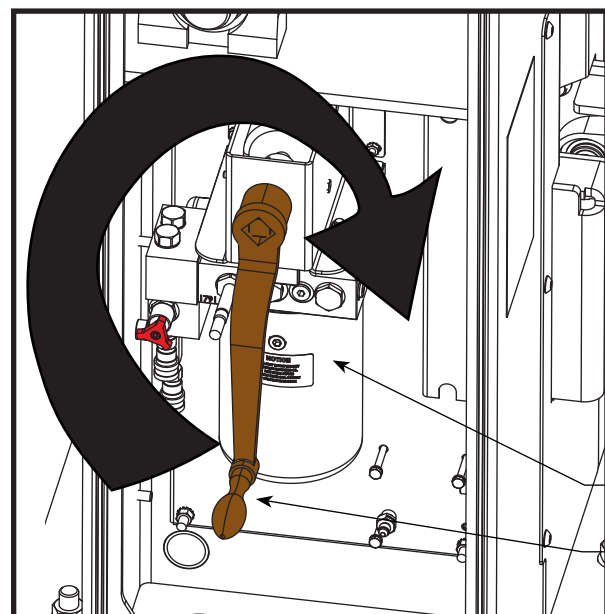

2 TO RAISE THE ARM:

Turn the crank handle, clockwise until the arm raises into position.

The arm maintains position when you stop.

Pump pack reservoir
Handle

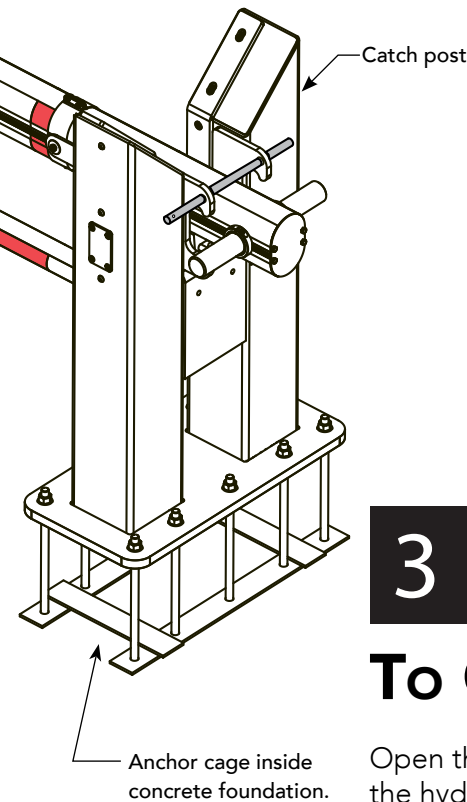

3 TO CLOSE THE ARM, USE GRAVITY:

Open the Manual Release Valve by turning the red knob **counterclockwise** 2 or 3 turns. This allows the hydraulic fluid to flow back to the pump pack reservoir.

As the arm descends, **reduce the arm speed by turning the Manual Release Valve clockwise.**

Continue to adjust the Manual Release Valve so the arm doesn't close too quickly and bounce as it comes to rest in the catch post. Average closing speed is approximately 20 seconds.

For general maintenance, refer to the *StrongArm M30/M50 Programming and Operations Manual*.

RECOMMENDED TOOLS

- High torque cordless drill with 1-inch, 12-point socket (Replaces hand crank. Faster method to open arm.)

Turn Manual Release Valve counterclockwise to allow fluid to flow back to the pump pack reservoir. The arm closes using gravity.

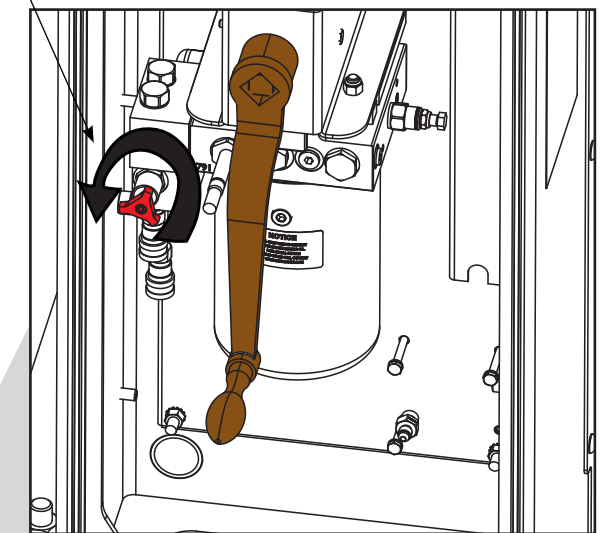

Keep personnel and equipment away from the clear opening. A closing arm can cause injury to personnel or damage to equipment.

CLEAR OPENING