

DESCRIPTION

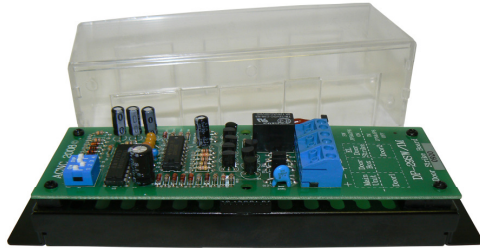

The **Telephone Keypad Relay Trigger** combines 2 former products into 1 device. Just by changing jumper settings, the **DP29-SW** or the **DP29-IM** can be selected. Both devices modify the telephone keypad to enhance your DoorBell Fon system.

DP29-SW: The **Outbound Relay Trigger Controller** will enhance the existing DoorBell Fon system by providing dry contact closure off the star (*) key or any other key selected by the DIP switch S1. This product is a great add-on that will trigger any electrical devices

that you may want to operate from your telephone just by pressing a keypad button. The DP29-SW is also known as the **Door Strike Controller**.

DP29-IM: The **Intercom Module** will enhance the existing DoorBell Fon system by converting all the phones in your home or office into an intercom system. No new wiring is required and no intercom installation is necessary. There is no programming required either. This module uses your existing phones and wiring without additional connections.

FEATURES

- New design footprint allows the DP29-SW/IM to be mounted in any structured wiring cabinet or even on the wall
- Jumper 4 allows easy selection between NO (normally open) and NC (normally closed) switches for customized installation
- S1 Dipswitch allows use of other keypad buttons other than the default (*) key
- No external power source required
- Simple wiring procedure in series with the Door Station
- Jumpers 5 and 6 can be removed to switch from the DP29-SW to the DP29-IM

DP29-SW:

- Able to operate any electrical device from 1.0 Amps at 125 VAC or 2.0 Amps at 30 VDC
- 3+ seconds of dry contact provided using the selected key on the phone (contact time may be extended by simply holding the selected key)

DP29-IM:

- Intercom call is initiated by a press of a keypad button
- No programming required
- Compatible with wireless phones
- Only 1 unit required to operate all phones

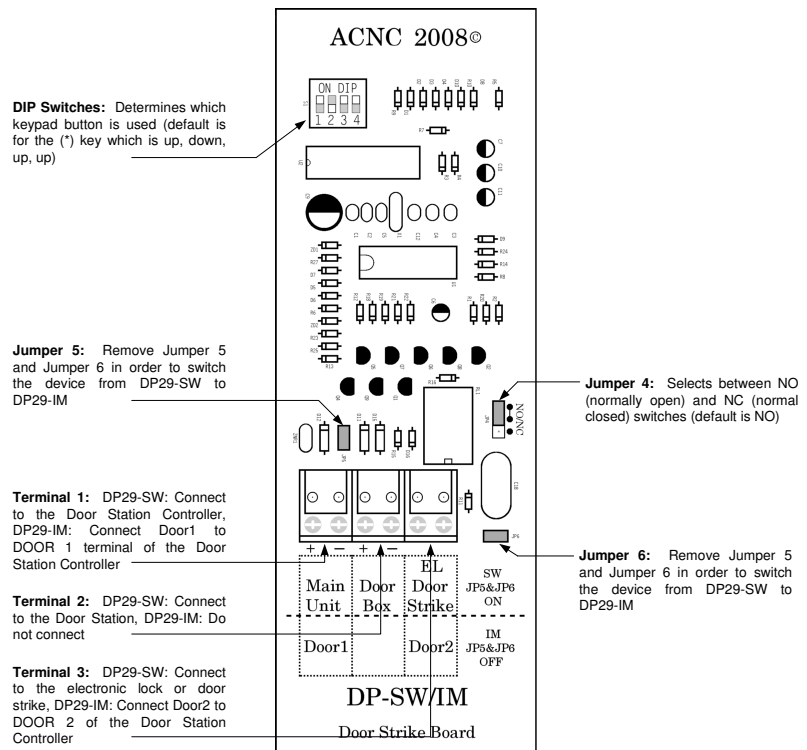



APPLICATIONS

One Outbound Relay Trigger with Door Strike and Door Station and One Intercom Module

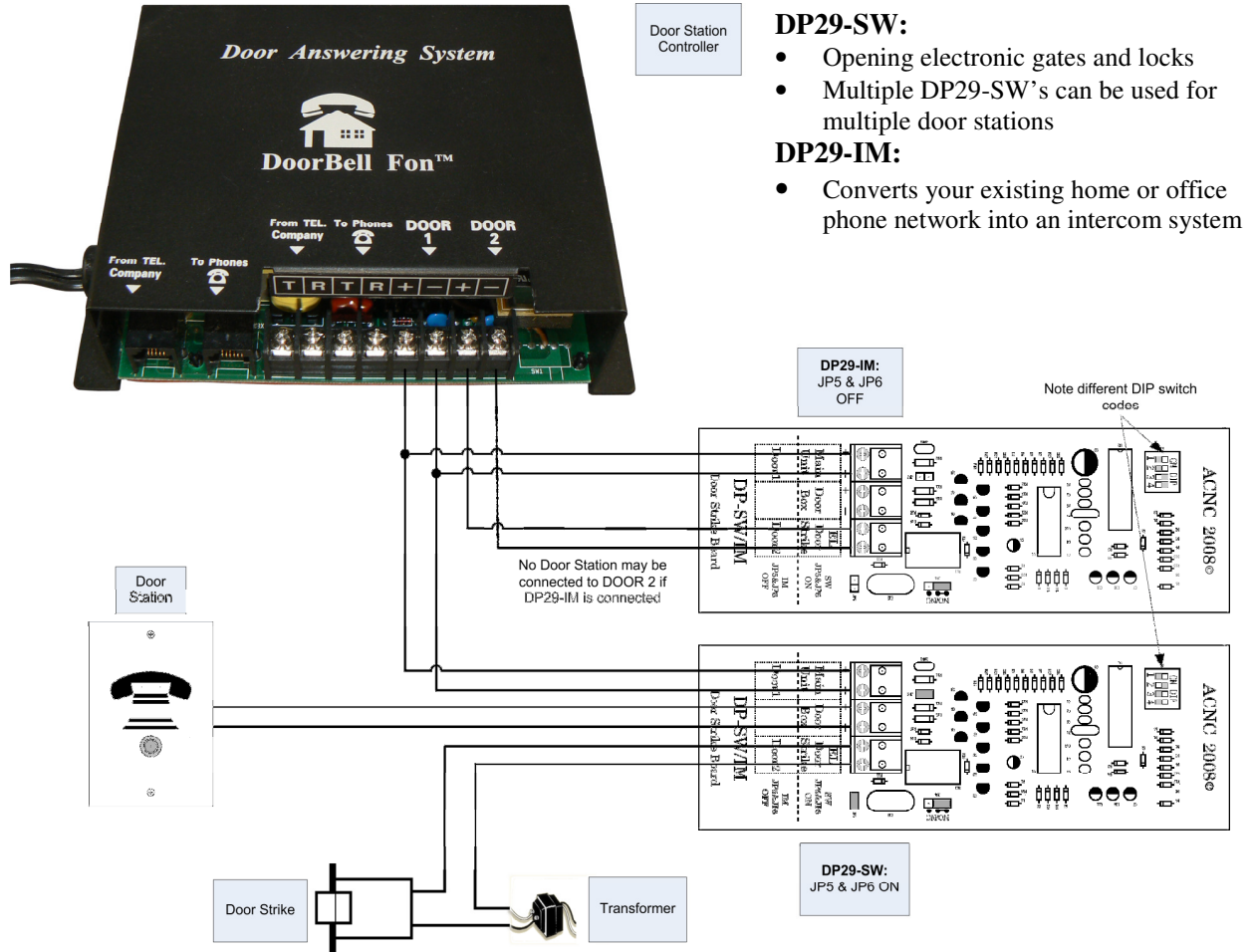

SPECIFICATIONS

Power:

- None

Dimensions:

- 5.750" x 2" x 0.875"
- 6" x 2.188" x 1.750" (w/ dust cover)
- 6.875" x 2" (base w/ butterfly clips)

