

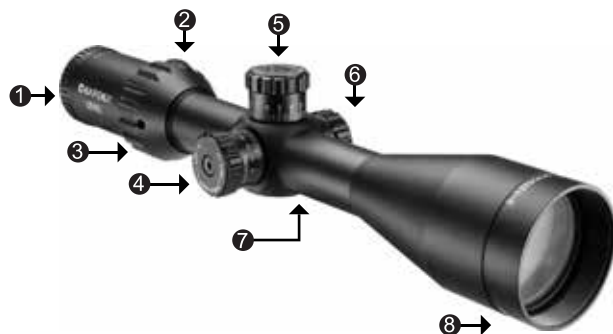

LEVEL™ Riflescope Manual



Parts of the Scope

- | | |
|-------------------------------------|-------------------------|
| 1. Eyepiece | 6. Parallax Adjustment |
| 2. Rheostat and Battery Compartment | 7. Accu Lock |
| 3. Zoom Ring | 8. Objective Lens |
| 4. Windage Adjustment | * Actual model may vary |
| 5. Elevation Adjustment | |



WARNING

BE CERTAIN THAT YOUR FIREARM IS NOT LOADED AND POINTED AWAY FROM YOU IN A SAFE DIRECTION

DIRECTLY VIEWING THE SUN OR ANY LIGHT SOURCE WITH THIS OPTICAL DEVICE CAN CAUSE PERMANENT EYE DAMAGE.

Use safe gun handling procedures at all times.

ATTENTION: All shooting should be done in an approved range and in a safe area and that eye and ear protection is used

DANGER: If you used a bore sighting collimator or another bore obstructing device, remove it before proceeding. If the barrel has been drilled for a mount, ensure that the screws do not obstruct the bore. Do not fire live or even blank ammunition with an obstructed barrel as any obstruction can cause serious damage to the gun and the possible injury to yourself and other people around you.

Focusing

1. Hold the scope about 3 to 4 inches (8 to 12cm) away from your eye and look through the eyepiece until you see the full field of view.
2. If image isn't sharp first adjust the parallax until image is clear. After image is clear if reticle is blurry then adjust the eyepiece focus until both the reticle and image is clear.

Mounting

1. Make sure you have the appropriate rail for your rifle, if not your firearms dealer will assist you.
2. Place and secure the scope onto the mount ring. (Not Included). Once you have fitted the scope to your desired position, tighten the mount ring down onto the rail.

Pre-Zeroing

1. Pre-zeroing sighting can be done with scope guide or a bore sight which can be obtained from your firearms dealer.
2. With scope mounted set zoom to mid power and rest the rifle on a steady support.
3. Look through the bore from the breech at a target 50 yards away. Move to butt stock so that the target is in the center of the bore.
4. Without moving the rifle, turn the windage and elevation adjustment dials with fingers in the direction you wish the bullet's point-of-impact to change. (up/down, left/right)

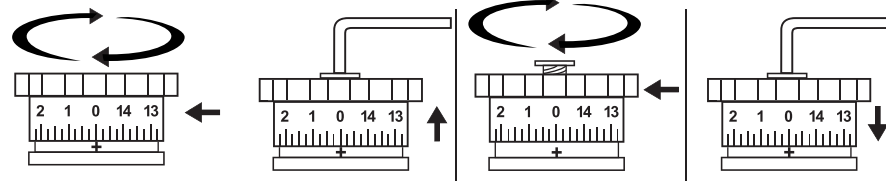

Note: If a large amount of windage and elevation adjustments are needed to bore sight, make half of the scales available adjustments at a time for the windage and elevation.

Boresighting

Bore sighting your riflescope with you rifle will allow you to quickly and more accurately "zero in" or "sight in" your riflescope to the correct shooting distance. You will always need to shoot a test group of shots after you bore sight your rifles to you rifle. Bore sighting your riflescope will reduce wasting ammunition when targeting in your rifle during test shooting.

Example: You have a newly mounted zoom power riflescope on a rifle and aim at a target 100 yards away. You aim for the center of the target with the scope and fire for the first time, but you see no impact on the target in the view of the scope. If you were not able to see where the bullet actually landed then you would need to guess how you need to adjust the scopes windage and elevation on the next shot. You would need to continue shooting multiple test shots and adjusting the scope until the actual impact of the bullet comes into view of the scope. This will waste time and ammunition.

Why does this happen? A newly mounted riflescope's actual zero point on a rifle is unknown due to many variables; type of scope base, height of mounting rings, type of rifle, type of ammunition etc.

Zeroing

Set scope zoom to the max power, and adjust the windage and elevation knobs as needed to correct the aim.

After zeroing in your scope (point of impact matches the center of scope sight.) You can follow Re-zeroing procedure to set turrets back to zero.

Each click adjustment of the windage and elevation changes/moves the bullet strikes by the amount in chart below 1/4" MOA

Windage / Elevation (inches per click or movement)			
50yds	100yds	200yds	300yds
1/8"	1/4"	1/2"	3/4"

Re-Zeroing

Re-zeroing scale back to zero is optional and should only be done after zeroing in your scope.

1. Use an allen wrench to gently loosen the screw to disconnect the turret from the drum inside. DO NOT remove screw. Pull the turret cap gently all the way up to disconnect it from the drum inside.
2. Turn the turret cap to reset the scale to zero.
3. Gently push the turret cap down to lock it in place. Use an allen wrench to gently tighten the screw to connect the turret to the drum inside.
4. Your scale is now re-zeroed.

Illuminated Moa Reticle

The black MOA illuminates to red for low light targeting or green for daylight targeting. The adjustable reticle brightness button for each color offers variable lighting intensities. When replacing batteries use CR2032 with the "+" side up.

MOA Reticle

MOA Reticle
The space between each hash mark is 2 MOA, 2" @ 100 yds. The Moa measurements are accurate at 10x magnification.

MOA measurement is very effective for ranging. To use the MOA Ranging formula, shooter needs to know the size of the target or nearby objective in inches. MOA Ranging Formula

$$\frac{\text{Target Size (Inches)} \times 95.5}{\text{Moa Measurements}} = \text{Range (Yards)}$$

Use either the vertical or horizontal MOA scale, place the reticle on target of known dimensions and read the number of MOA. Accurate MOA measurement reading will depend on how steady the scope is held.

Note: Can multiply by 100 instead of 95.5 for quicker calculations, but will be less accurate. Ex: Use Person: 65" Tall add into MOA scale chart and do calculations.

See reverse side for additional information

Here are some suggestions, to increase your range estimation skills

- Build targets of known dimensions such as 1 yard squares and number them so that the targets can be seen from a distance.
- Now place the targets at various ranges making sure that the targets are visible from the start point.
- Return to the start point. With a notepad, number left side of the pad with the number of targets you have put out.
- Look at the targets you have put out and determine the range with the naked eye. Write down this figure on your note pad next to the corresponding target number. This will help you develop your eye skills and assist you in estimating range by optics.
- After your finished determining the range with the naked eye, establish a stable shooting position with your unloaded rifle or mil dot equipped spotting scope.
- Use the formula listed below to determine range. Using an odometer or a measuring wheel determine the actual range to the targets.
- Compare the actual range between using a measuring wheel, naked eye and using mils.

$$\frac{\text{Height of target (yards)} \times 1000}{\text{Height of target}} = \text{Range (yards)}$$

Windage & Moving Targets

It is possible for you to use your MOA scope for calling wind, will help you develop the skills for using your MOA scope. By practicing and attending competitions, even as an observer, will help you develop the skills for using your MOA scope. Watching and asking experienced shooters with the wind, and moving objects, will help you become stronger at using the MOA for windage & moving targets.

This skill is extremely difficult, as well as difficult to train. However, if you have the means of making a moving target in an area where you can train you should do so at every opportunity. Here are some suggestions on moving targets

- Start with slow speeds and then build speed as skill increases. Do not increase target speed until you can hit them 90% or better all of the time.
- Use a target size that at a minimum replicates the kill zone of your intended target. In the beginning, a larger target should be used to show hits to allow you to adjust your leads/actions.
- Begin training at close ranges, (50yards) and increase as your skills increase.
- You should use a partner slightly behind your shoulder with a spotting scope and looking for a bullet trace and provide you with the feedback as to where the bullet is landing

Parallax Adjustment

Yardage increments are printed around the radius of the parallax adjustment knob. The adjustment knob can be is designed to be easily located and to be adjusted with the left hand while looking through scope.

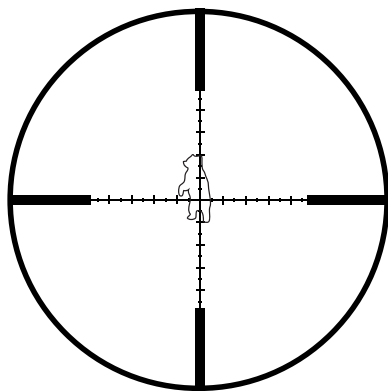

Accurate at 10x Magnification

1 Moa = 1" @100 yards
2 Moa = 2" @100 yards
4 Moa = 4" @100 yards
20 Moa = 20" @100 yards

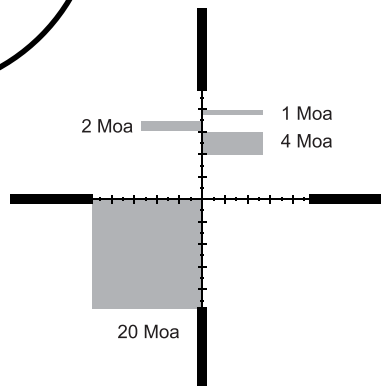

Accu-Lock System

Accu-Lock System utilizes a coil spring positioned within the scope to securely lock the inner tube. This coil positioning system allows the scope to stay locked dead-on to the target shot after shot and minimizes the zero maintenance of the scope for pinpoint accuracy. It is not necessary to adjust the Accu-Lock System manually and **NO ADJUSTMENT KEY IS REQUIRED**. Once you have zeroed your scope using the windage and elevation adjustments, the scope will maintain the zero setting until it is necessary for you to re-adjust the scope.

Sunshade

Sunshade can be attached to the scope to reduce glare. To attach included sunshade simply screw sunshade onto the objective of the scope.

Maintenance

Your riflescope is shockproof and waterproof but you should not take it apart or clean it internally. If your scope requires repairs or adjustment you should bring it your firearms dealer or an authorised service center. Please refer to the warranty section for further details.

The exposed optical surfaces can be wiped clean occasionally with the included lens cloth or with a special optical cleaning cloth. It is recommended to keep the protective lens cover on the scope when not being used.

The metal body of your scope can be cleaned by using a soft brush or a damp cloth followed by a soft cloth. To maintain the scope, you can use a silicon treated cloth to restore luster and protect the scope against corrosion, however do not touch the lenses with the silicone cloth.



LIMITED LIFETIME WARRANTY

BARSKA® Optics, as manufacturer, warrants this new precision optical product to be free of original defects in materials and/or workmanship for the length of time specified by this warranty. This warranty does not include damage caused by abuse, improper handling, installation, maintenance, normal wear-and-tear, unauthorized repairs or modifications and tampering in anyway.

This warranty is limited to the original purchaser and is not transferable. This warranty applies only to products purchased in the United States of America.

In the event of a defect within 30 days, the consumer must return the defective unit to the BARSKA dealer (the place of purchase) at his/her own expense.

Beyond 30 days, BARSKA products should be sent to the following address for warranty repairs. Products must be packed carefully and sturdily to prevent damage in transit, and returned freight prepaid to:

BARSKA® OPTICS
Repair Department
855 Towne Center Drive
Pomona, CA 91767

For additional and updated information please visit our website at www.barska.com

Please email info@barska.com or call 1-888-666-6769 for Return Merchandise Number (RMA#) before any returns. NOTE: All merchandise received without a valid RMA # will be returned to shipper at his/her own expense.

Please include all of the following when returning BARSKA products for service and/or replacement:

1. Please write your complete details (Name, Address, Telephone #, E-mail address, RMA#, etc.)
2. Purchase receipt or Proof of Purchase. (Original/Copy)
3. A brief explanation of the defect.
4. A Check/Money Order of \$25.00 to cover inspection, shipping and handling.

*Please allow 6-8 weeks for delivery.

This product will either be replaced or repaired at the discretion of the warrantor. If it's a discontinued item, we will replace the product with an equivalent product. Should the repair not be covered by this warranty, an estimate will be sent for your approval. Non-warranty repairs or refurbishing of your optical products are always provided at a reasonable cost.

BARSKA® Optics shall not be liable for any consequential, incidental and/or contingent damages whatsoever. We will not pay shipping, insurance or transportation charges from you to us, or any import fees, duties and or taxes. This warranty supersedes all previous BARSKA® Optics warranties.