

**UL-2016 Photoelectric Beam Sensor
(Retro-Reflective & "POLARIZED" also Twin Finish Housing Type)**



Features:

- "Polarized Sensor"- totally safety sensor
- Retro-reflective type
- Red infrared led element
- IP-55 waterproof/cable gland
- PC casing, antifog/dew/rains
- Round shape reflector-Dia.: 82.1mm
- Input Volt.: 12-30VDC/AC 60 Hz (Non Polarity)
- Twin colorsled indicator for beamalignment
- Tamper switchesincluded

Application:

- Gateopener
- Overhead door
- Swing gate
- Sliding door
- Window
- Terrace
- Warehouse
- Parking lot
- Automation control



Specifications:

Input Volt.	12-30V DC/AC 60 Hz (Non Polarity)
Current consumption	100 mA
Tx LED Element	Infrared LED/Wave length 740 nm
Beam Spreading angle	1.5° (half angle)
Contact Capacity	30VDC/AC, 0.5A
Response Time	10 msec
Delay Time of Relay	100 msec
Sensing Range	10 meters
LED Indicators	Red LED Off: Beam aligned / Red LED On: Beam broken Red LED flash: Beam alignment signal weak (Re-align) Green LED on: Beam aligned proper
Additional Function	Tamper switches
Wiring Connection	Terminal block / Cable gland (IP-55)
IP	IP-55
Environment/Storage Temp.	-25°C ~ 60 °C / -35°C ~ 80 °C
Dimension	122 (L) × 61 (W) × 62 (D) mm
Cable wires	2517 / 24AWG / 5~7 cores
Approvals	UL-2016 & CE

Note:

MONITOR functions of UL325

Depending on the monitoring system used by the gate motor, it may be necessary to use either the N.C. output or connect the included 10KΩ resistor to the N.O. or N.C. output.

Please refer to the gate operator manual or the gate operator manufacturer for the preferred monitoring method.

Dimensions:

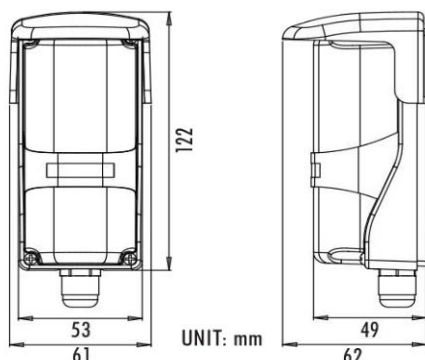

Cable gland:

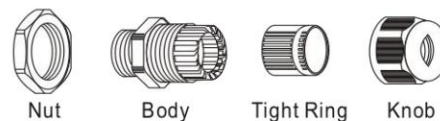

Thread	Cable Range (mm)	Thread O.D. C1(mm)	Thread Length C2(mm)	Spanner Size A&F(mm)
M12x1.5	3-6.5	12	9	18/15

Mounting the Sensor:

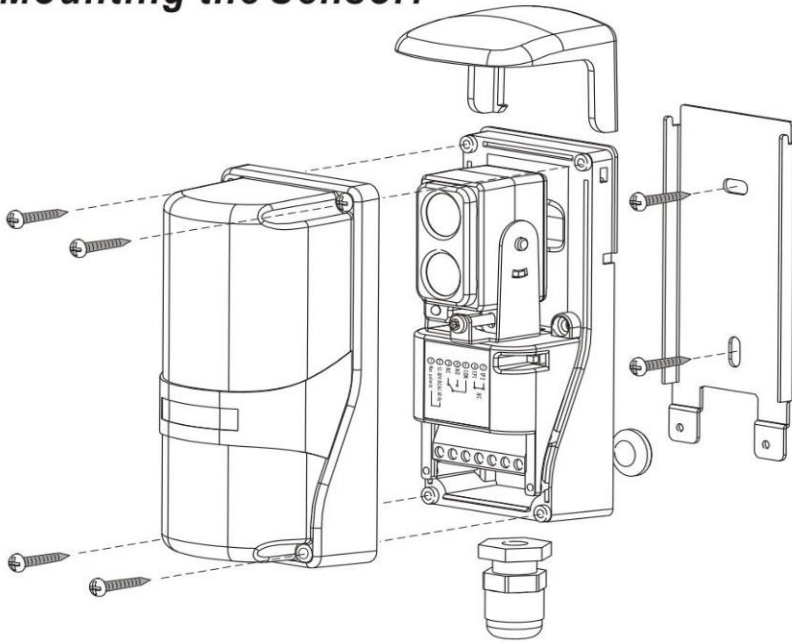

1. Unscrew the 4 screws and remove the cover.
2. Loosen the captive screw to free the sensor from the mounting plate.
3. Using the included screws, mount the mounting plate to the wall.
4. Use the breakout and cable gland at the bottom of the sensor to run the wires.
5. Remove the terminal block using long-nose pliers and wire the unit according to the wiring diagram above.
6. Hang the sensor back on to the plate, and use the captive screw to secure it in place.
7. Re-attach the cover, and use the Included small screws to secure it.
8. Attach the hood to the top of the sensor.

Wiring connection:

- ① Break down & remove plastic pack **A**

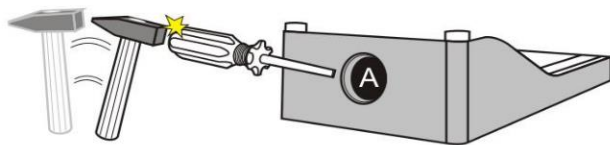

1. Please use screwdriver & hammer to break **A** plastic pack down and remove pack **A**. Then insert the cable gland into the **A** empty hole. (See diagram 2)

- ③ Finish the wiring connection:

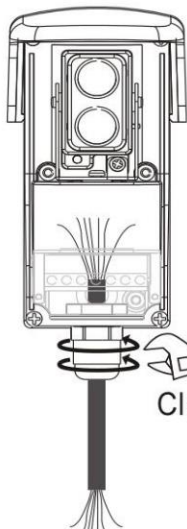

- a. Insert the cable wires into the cable gland.
- b. Connect the lead wires to the proper position of terminal block.
- c. Use spanner to tight the cable gland clockwise to the end (the most tightness).

Clockwise

- ② Install the cable gland

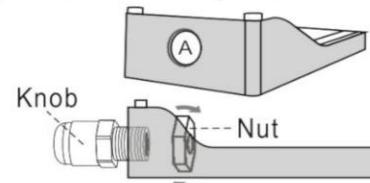

2. Then screw the knob with the nut till them fixed.

Wiring:

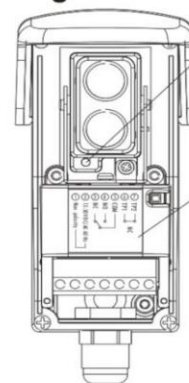

**PWR/
Beam Alignment
LED Indicator**

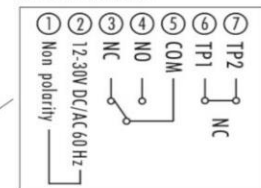

Additional function:
TP1/TP2 - Tamper Switches,
can be connected with control
panel or siren as burglar alarm.

CONNECTION GUIDE FOR BFT CONTROL BOARDS					
TERMINAL	DESCRIPTION	HAMAL	MERAK UL	ZARA	THAILA UL RIGEL-6 UL
1	12 - 250 V AC/DC	50	50	50	50
2	12 - 250 V AC/DC	51	52	52	52
3	Relay, Normally Closed	72	72	72	72
4	Relay, Normally Open		73	73	73
5	Relay, Common	70	70	70	70
6	Tamper Switch, N.C.				
7	Tamper Switch, Common				

! ATTENTION! Remove Jumper Wire From Terminal # 70 - #72