

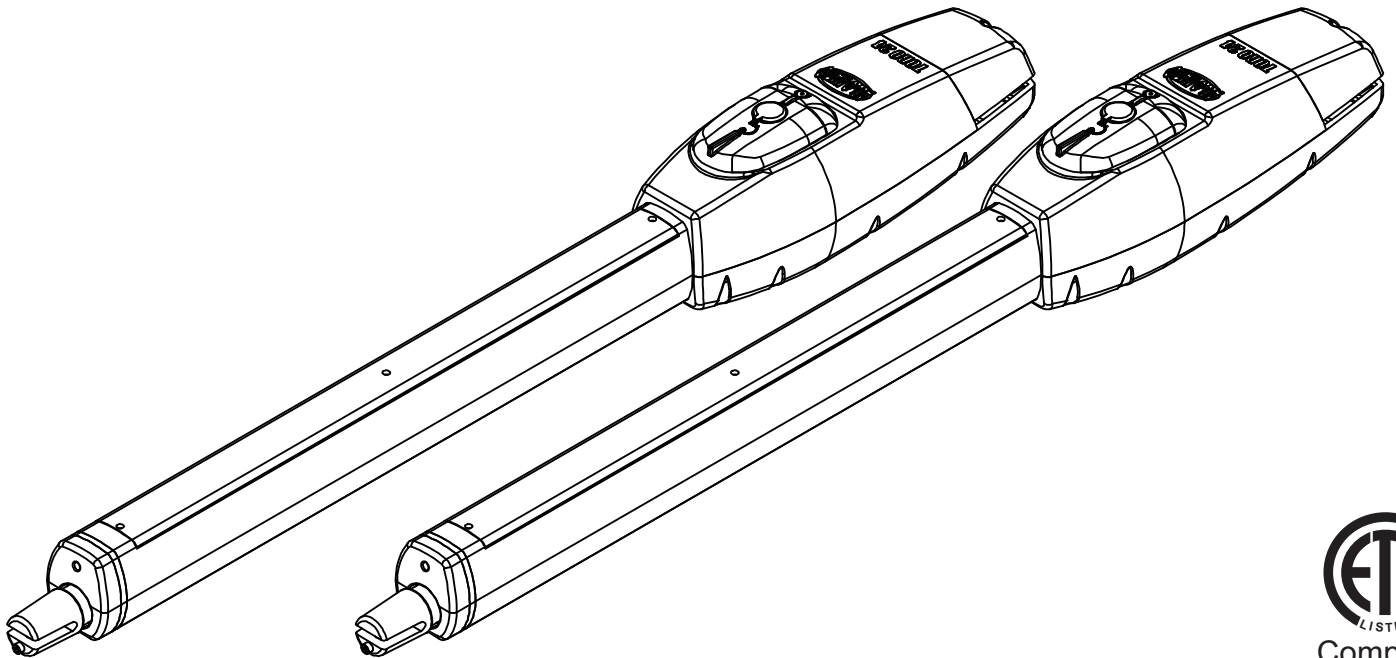

TORO 24 **PRIME**



SWING GATE OPENER

INSTALLATION MANUAL



Compliant

UL325
Compliant

UL991
Compliant

Canada
CSA C22.2
Compliant

Copyright © 2019 All-O-Matic inc. www.allomatic.net



TABLE OF CONTENTS

•		
•	IMPORTANT SAFETY INSTRUCTIONS.....	1-2
•	DIFFERENT UL 325 CLASS TYPES.....	3
•	PARTS IDENTIFICATION.....	4
•	OPEN INSIDE INSTALLATION.....	5
•	OPEN OUTSIDE INSTALLATION.....	6
•	GATE OPERATOR INSTALLATION.....	7
•	MOTOR WIRING.....	7
•	EMERGENCY RELEASE.....	8
•	LIMIT SWITCH ADJUSTMENT.....	8
•	LCD SETTINGS AND PROGRAMMING.....	9-10
	SETTING TIME & DATE.....	9
	SETTING MOTOR SPEED.....	9
	SETTING MOTOR POWER.....	9
	PROGRAMMING 7 DAY TIMER.....	9
	SETTING LEAF DELAY.....	9
	SETTING AUXILIARY RELAY.....	9
	SETTING SERVICE CYCLE.....	9
	SETTING LIMIT SWITCH CONFIGURATION.....	10
	SETTING TO FACTORY DEFAULT.....	10
•	LCD DIAGNOSTICS.....	10
	GATE STATUS.....	10
	METER.....	10
	MOTOR ONE AND MOTOR TWO.....	10
	EVENT LOG.....	10
	CYCLE COUNT.....	10
•	LCD MENU DESCRIPTION.....	10-11
•	ELECTRICAL CONNECTION.....	12
•	SWING GATE LOOP LAYOUT.....	13
•	GENERAL LOOP INSTALLATION GUIDELINES.....	14
•	ENTRAPMENT PROTECTION INSTALLATION.....	15
•	ENTRAPMENT PROTECTION DEVICE CONNECTIONS.....	16
•	ACCESSORY CONNECTIONS.....	17
•	LPR-1 LOOP RACK INSTALLATION.....	18
•	THREE BUTTON STATION SYSTEM.....	19
•	MAGNETIC/SOLENOID LOCK CONNECTION.....	20
•	RADIO RECEIVER CONNECTIONS.....	21
•	TIMER ADJUSTMENT.....	22
•	DIP SWITCH FUNCTIONS.....	23
•	SOLAR PANEL CONNECTIONS.....	24
•	LED DIAGNOSTICS.....	25

IMPORTANT SAFETY INSTRUCTIONS

WARNING

To reduce the risk of injury:

READ THE FOLLOWING DIRECTIONS. DO NOT START UNTIL YOU HAVE READ AND UNDERSTAND THESE DIRECTIONS. IF THERE IS SOMETHING YOU DON'T UNDERSTAND CALL US.

Never let children operate or play with gate controls. Keep the remote control away from children.

Always keep people and objects away from the gate. No one should cross the path of the moving gate.

This operator must be tested monthly. The gate must reverse on contact with a ridged object or stop when an object activates the non-contact sensors. After adjusting the force or the limit travel, retest the gate operator. Failure to adjust and retest the gate operator properly can increase the risk of injury.

Use the emergency release only when the gate is not moving.

Keep gates properly maintained. Have a qualified service person make repairs to gate hardware. It takes many years of experience to make proper adjustments to gate hardware or operators.

This entrance is for vehicles only. Pedestrian must use separate entrance.

There is nothing on a gate operator that is easily repaired without a great deal of experience. Save yourself some time and call a qualified Gate Service Contractor who knows your type of gate operator.

SAVE THESE INSTRUCTIONS FOR FUTURE REFERENCE

INSTALL THE GATE OPERATOR ONLY WHEN YOU HAVE READ THE FOLLOWING:

- * **Confirm that the gate operator being installed is appropriate for the application.**
- * **Confirm that the gate is designed and built according to current published industry standards.**
- * **Confirm that all appropriate safety features and safety accessory devices are being incorporated, including both primary and secondary entrapment protection devices.**
- * **Make sure that the gate works freely before installing the operator.**
- * **Repair or service worn or damaged gate hardware before installation of the gate operator.**
- * **Eliminate all gaps in a swinging gate below a 4 foot height that permits a 4 inch sphere to pass through any location, including the hinge area of the gate.**
- * **Operator must be disconnected from the power source before attempting any installation of accessories.**
- * **Install this gate operator according to our installation instructions.**
- * **Adjust the operator load sensing device to the minimum force setting that will still allow for reliable gate operation.**
- * **Install the operator inside the fence line (do not install the operator on the public side of the fence line).**
- * **Install a proper electrical ground to a gate operator.**
- * **Controls intended for user activation must be located at least six feet (6') away from any moving part of the gate and where the user is prevented from reaching over, under, around or through the gate to operate the controls. Outdoor or easily accessible controls shall have a security feature to prevent unauthorized use.**
- * **The stop and/or reset buttons must be located in the line of sight of the gate. Activation of the reset control shall not cause the operator to start.**
- * **Install a minimum of two(2) WARNING SIGNS, one on each side of the gate where easily visible and take pictures of installation.**
- * **Test all safety features for proper function before placing the automatic vehicular gate into service.**
- * **Train owner/users about basic functions and safety features of the gates system, including how to turn off the power and how to operate the manual disconnect feature.**
- * **leave safety instructions, product literature and installation manual with end user.**
- * **Explain to the owner/user the importance of routine service and retesting on a monthly basis.**

DIFFERENT UL 325 CLASS TYPES

Class one: Residential

A vehicular gate operator intended for use at a home of one to four single family dwellings, garage or parking area.

Class two: Commercial or General Public Access

A Vehicular gate operator intended for use at a commercial location or building such as a multi-family housing unit (five or more single family units), hotel, garages, retail stores, other buildings servicing the general public.

Class three: Industrial or limited access

A vehicular gate operator intended for use at an industrial location or building such us a factory, loading dock area, or other locations not intended to service the general public.

Class four: Restricted Access

A vehicular gate operator intended for use at a guarded industrial location or building such as airport security areas or other restricted access locations not servicing the general public where unauthorized access is prevented via supervision by security personnel.

Other components required to satisfy UL 325

Each class must have a primary and secondary means to sense and react to obstructions within two seconds.

The six types of obstruction sensing systems are:

Type A:

Inherent obstruction sensing system. This system must sense and initiate the reverse of the gate within two seconds of contact with a solid object.

Type B1:

Provision for connection of a non-contact device can be used, such as a secondary protection.

Type B2:

Provision for connection of a contact sensor. Examples include an edge device or equivalent. This can be used for secondary protection.

Type C:

Inherent adjustment clutch or pressure relief valve.

Type D:

Provision for connection of or provided with and actuation device requiring continuous pressure.

PARTS IDENTIFICATION

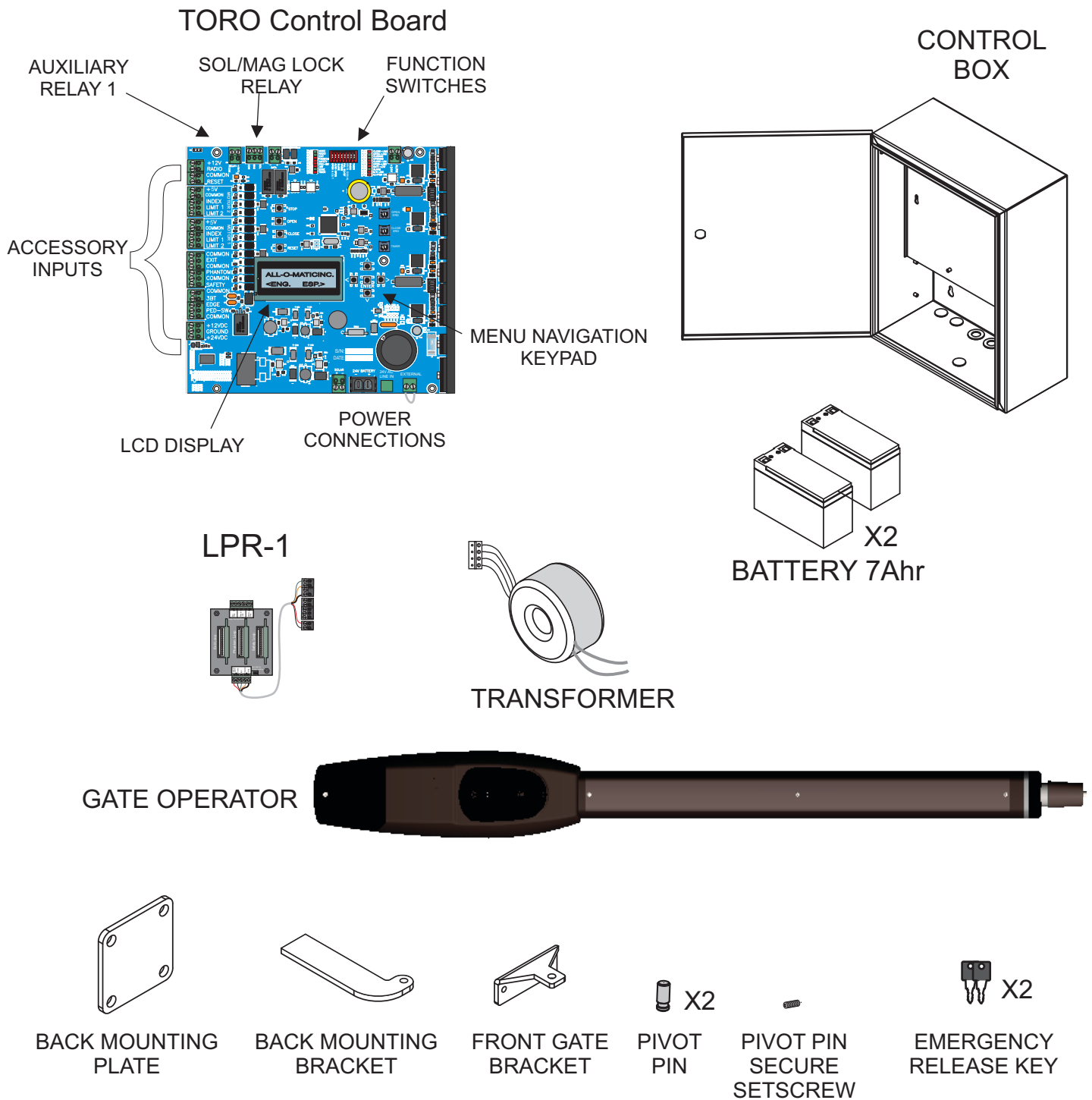

NOTE: Back mounting bracket must be cut to fit geometry requirements. Use back mounting plate when a steel post is not available to weld the back mounting bracket.

OPEN INSIDE INSTALLATION

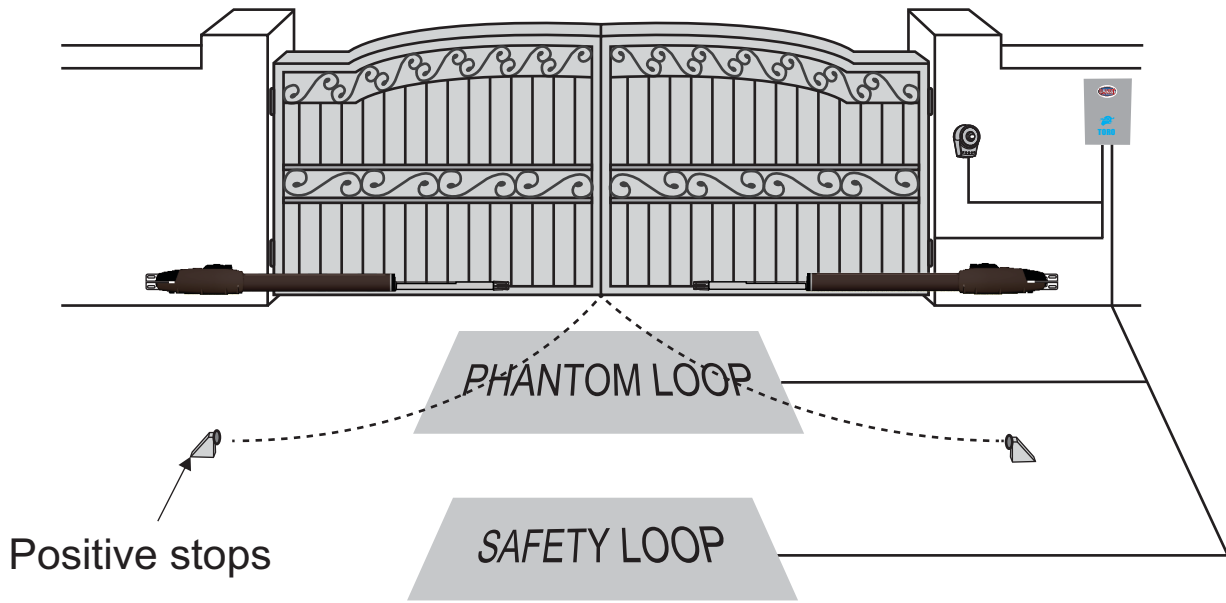

Comply with the measurements shown for proper installation. Adjust the gate structure to optimize for best automation performance, if necessary.

Before proceeding with installation, be sure that gate moves freely and the following:

- 1) Hinges are properly positioned and lubricated.
- 2) No obstructions are in the path of the swinging gate.
- 3) No frictions between two leaves or with the ground while moving.

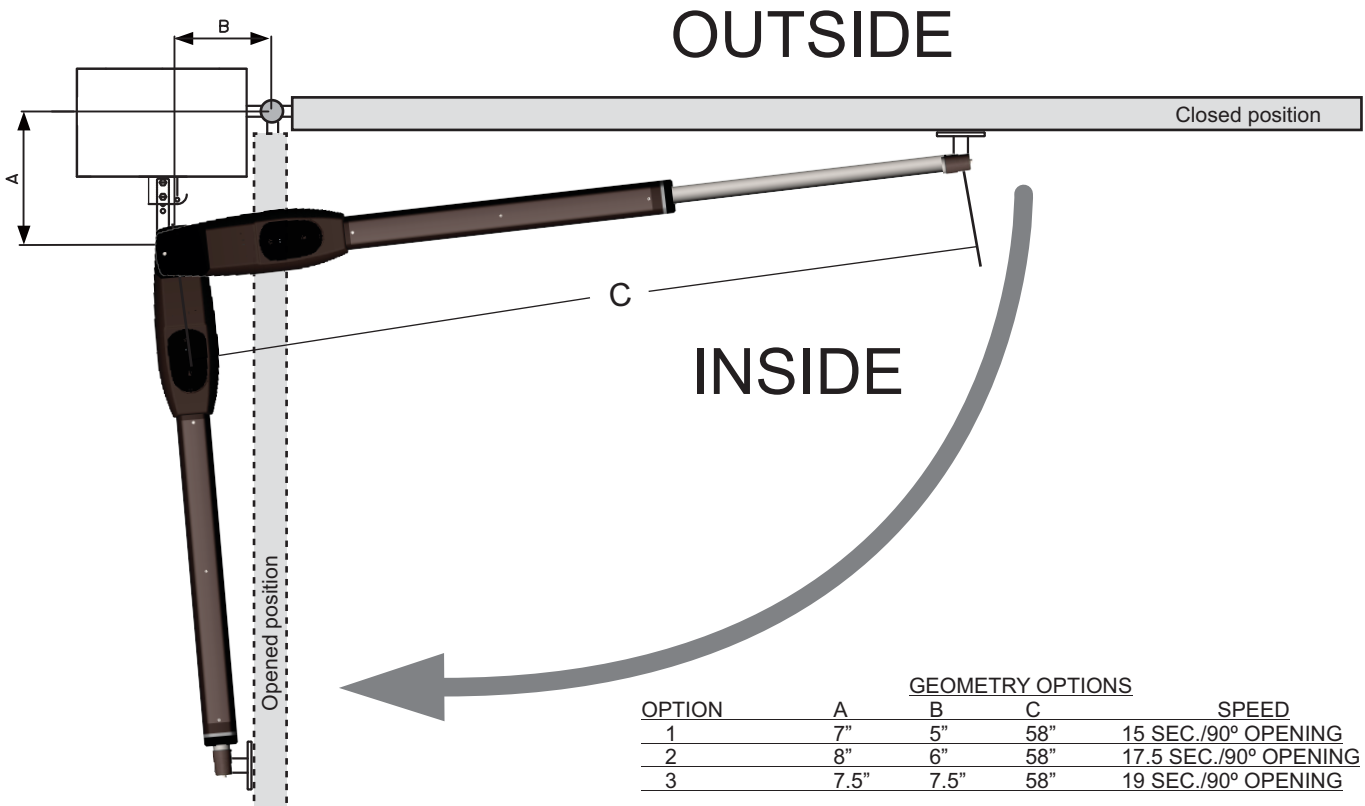

OPEN OUTSIDE INSTALLATION

Comply with the measurements shown for proper installation. Adjust the gate structure to optimize for best automation performance, if necessary.

Before proceeding with installation, be sure that gate moves freely and that:

- 1) Hinges are properly positioned and lubricated.
- 2) No obstructions are in the path of the swinging gate.
- 3) No frictions between two leaves or with the ground while moving.

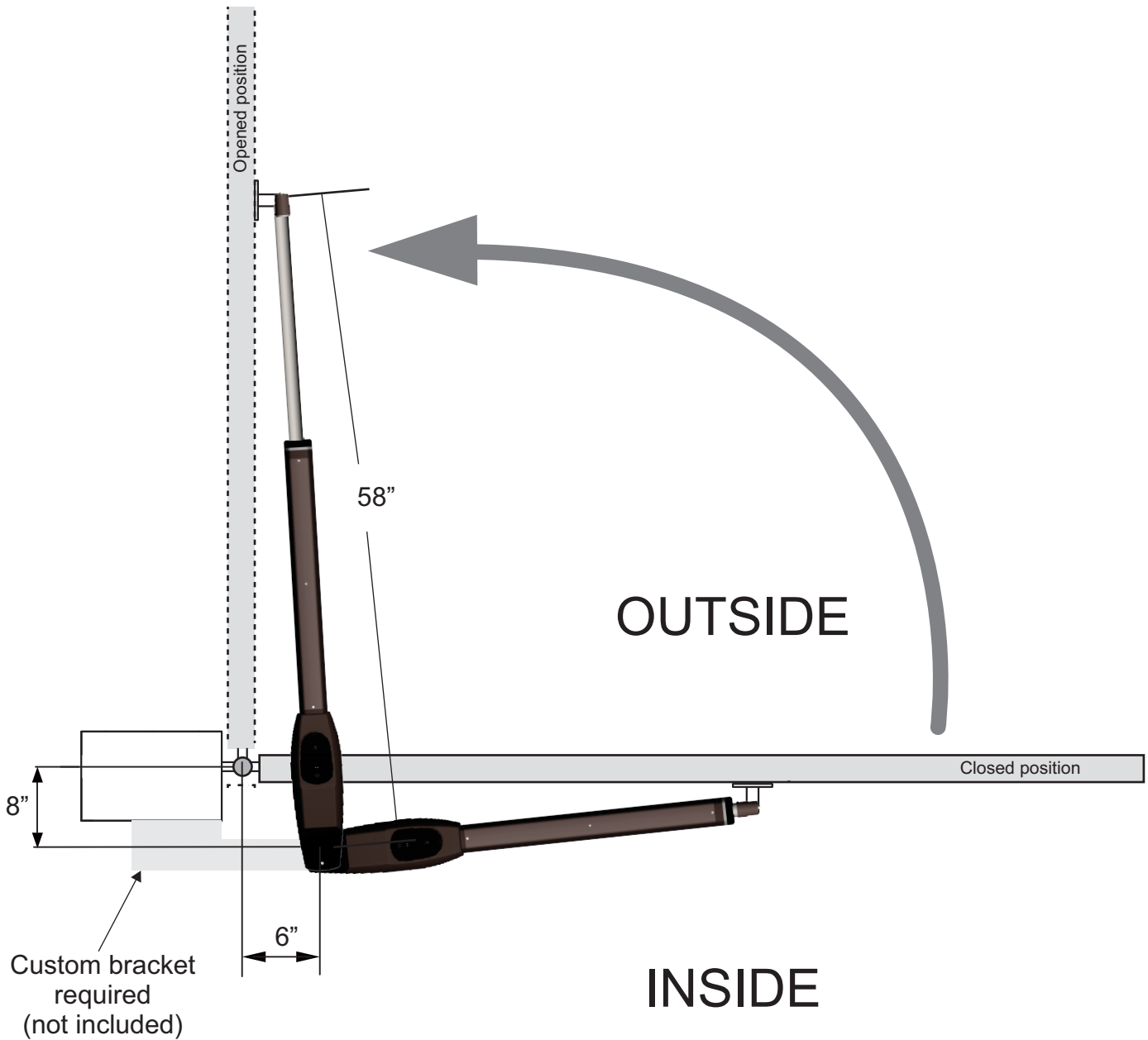

GATE OPERATOR INSTALLATIONS

When a steel post is not available use the back mounting plate to have a welding surface.

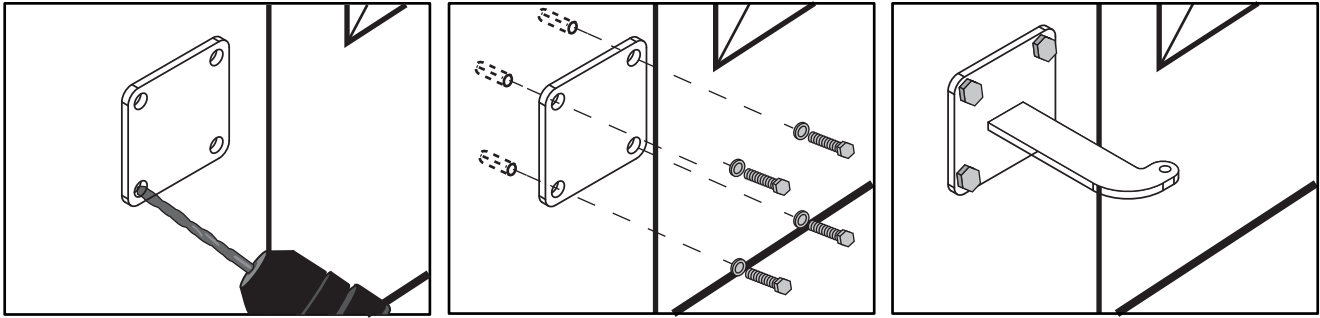

Mount the **back mounting plate** to the pillar using anchor bolts. Cut the **back mounting bracket** to fit the geometry and weld to the **back mounting plate** or the steel post (if available). NOTE: For OPEN OUTSIDE installation a custom mounting plate(not provided) is required to fit geometry.

Remove the wire connection cover and attach the back mounting bracket with the pin. Release the gate operator and place the pin into the fitting position no. 1 and no. 2 shown below. Use the setscrew to hold pin no. 2 in position.

Make sure the gate operators are mounted in horizontal position especially in the CLOSE, OPEN and 45° positions.

Prior to welding the front gate bracket on the gate leaf(if necessary), cover the gate operator to prevent damage from welding sparks.

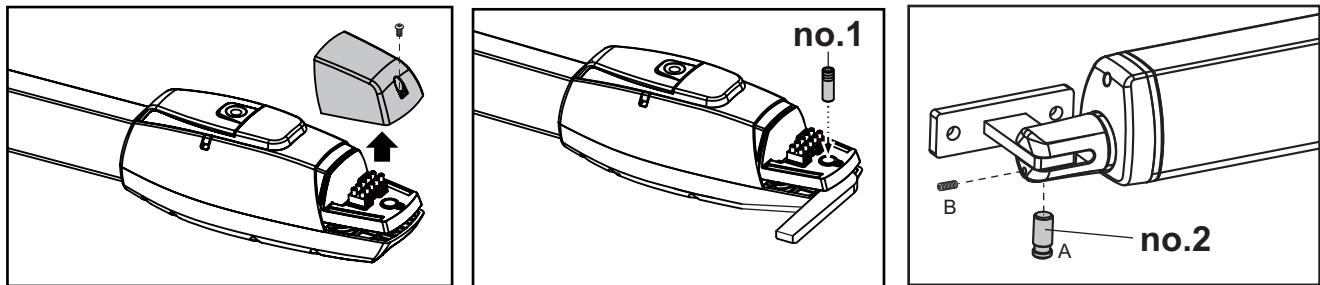

WIRE CONNECTION:

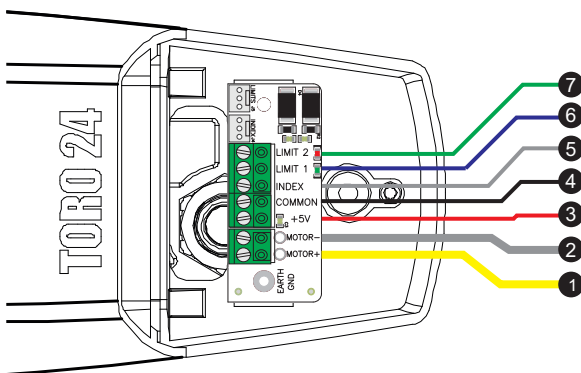

①	Yellow or Red	Motor (+)
②	White or Black	Motor (-)
③	Red	+5V
④	Black	COMMON
⑤	White	INDEX
⑥	Blue	Limit 1
⑦	Green	Limit 2

- (1) Avoid tension in the cable during open and close cycles.
- (2) Always connect the grounding wire(GND)

EMERGENCY RELEASE

In case of failure, insert the key and turn counter clockwise to unlock, then turn release handle counter clockwise to release. To latch back to normal operation, simply reverse the procedures.

Step1. Insert the key and turn Counter Clockwise to unlock

Step2. Turn the Release Handle Counter Clockwise to release

To restore the automation, simply reverse the above procedure.

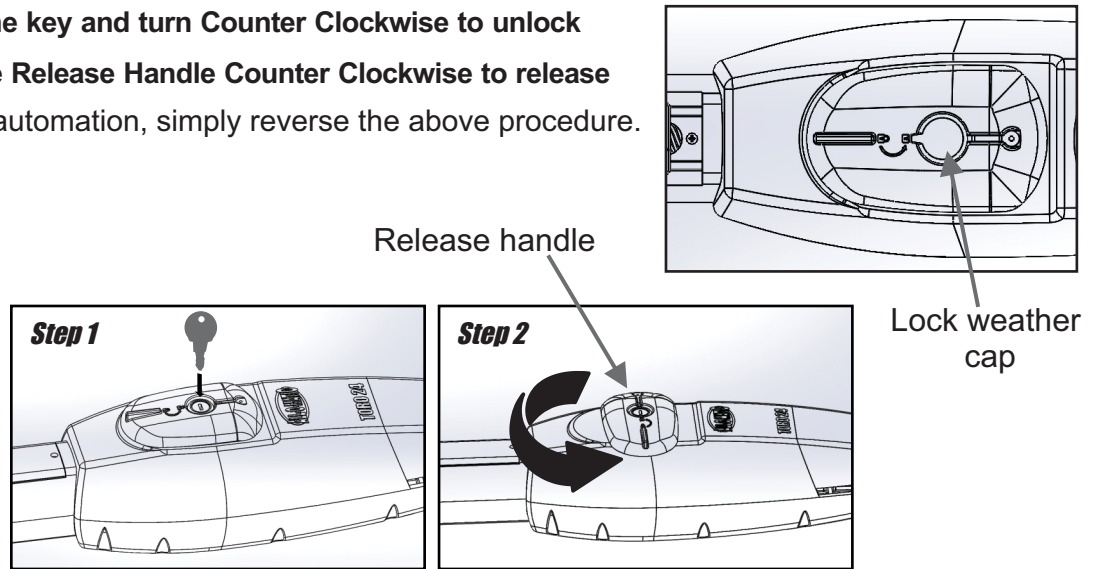

LIMIT SWITCH ADJUSTMENT

EASY STEPS TO ADJUST LIMIT SWITCHES

1. Remove limit cover.
2. Find the open and close limits on top of the actuator.
3. Loosen the limit switch screws to allow it to slide and make the open and close adjustment.
4. Once the open and close limits have been set, tighten the screws with a phillips screw driver to lock limits in place.

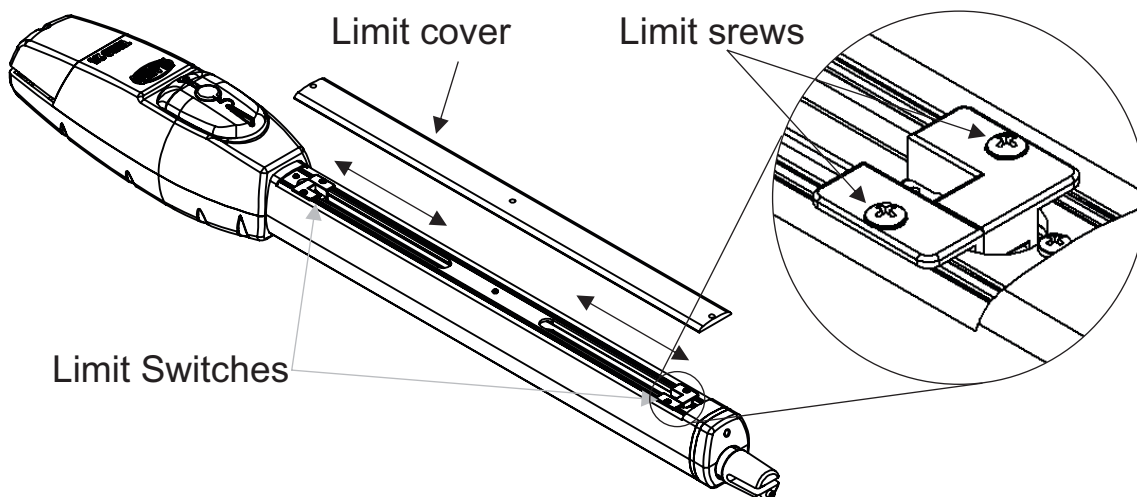

SETTINGS MENU

ADVANCED FEATURES



ENTERING THE SETTINGS MENU

Press the **ENTER** button twice to wake up the LCD display. Press the **<** (left) button to select **ENGLISH**. Select **SETTINGS**, then press **ENTER** (the left **<**- arrow indicates selection). Use the **UP/DOWN** buttons to scroll through the menu list. Make selection, then press **ENTER**. The **<** left button could be use to go back to previous screen.

Setting TIME and DATE:

From the **SETTINGS** menu select the **TIME & DATE**, then press **ENTER**.

- Move cursor to **TIME**, then press **ENTER** to edit time. The time editor will then open. Use the **< RIGHT/LEFT >** buttons to move from hours to minutes and **AM/PM** and **UP/DOWN** buttons to change the time. Press **ENTER** button to save **TIME**.
- Move cursor down to **DATE**, then press **ENTER** to edit **date**. Use the **< RIGHT/LEFT >** buttons to position cursor and **UP/DOWN** buttons to change the date. Press **ENTER** to save the **DATE**.
- Once **DATE** is saved the weekday needs to be set. Use **UP/DOWN** buttons to scroll through the days of the week. Press **ENTER** when the correct day of the week is displayed.

Setting Motor SPEED

From the **SETTINGS** menu select **SPEED**, then press **ENTER**. In this sub-menu there are three settings that can be adjusted. Using **UP/DOWN** buttons move the cursor to selection and press **ENTER** to edit each of them.

- **MAX SPEED:** This can be adjusted from **50-100%**. This is the maximum operational speed of the gate. Use the **UP/DOWN** buttons to change the % value and press **ENTER** to save.
- **ACCELERATION:** This can be adjusted from **SLW** (slow), **MED** (medium) and **FST** (fast). This is how fast the gate will ramp up (accelerate) at motor start. Use the **UP/DOWN** buttons to change the setting and press **ENTER** to save.
- **SLOW/DOWN:** This can be adjusted from **70-95%**. This is the percentage of travel where the gate will start slowing down as the gate approaches the open or close limits. Use **UP/DOWN** buttons to change the % value and press **ENTER** to save.

Setting Motor POWER

From the **SETTINGS** menu select **POWER**, then press **ENTER**. In this sub-menu there are two settings that can be adjusted. Using **UP/DOWN** buttons move cursor to selection, then press **ENTER** to edit each of them.

- **TORQUE:** This can be adjusted for **LOW**, **MED** and **HIGH**. Use **UP/DOWN** buttons to change the setting and press **ENTER** to save.
- **CURR. SENSE:** This sets the way current sense is read. **THLD** (threshold) for normal operation(default). **PRGV** (progressive) for windy areas. Use **UP/DOWN** buttons to change from **THLD** and **PRGV**, then press **ENTER** to save.

Setting the 7 DAY TIMER:

From the **SETTINGS** menu select the **7/DAY TIMER**, then press **ENTER**.

- In the event list, select the **EVENT #** that you would like to program, then press **ENTER** button.
- Select the **ACT.** (action) by scrolling through the different actions

- then press **ENTER** when desire action is displayed.
- Set the time for the action. Using the **UP/DOWN** buttons to change the time and **RIGHT/LEFT** buttons to move from hours, minutes and **AM/PM**. Press **ENTER** button to save the action time.
- Last, set the days of the week that you would like the action to be in effect. Use the **UP/DOWN** buttons to scroll through the days and the **RIGHT** button to toggle the day **ON/OFF**.

Repeat process for each event (1-10 events available).

Action list:

- **OFF (DISABLED)** Nothing happens.
- **OPEN** (opens the gate once)
- **OPEN & HOLD** (opens the gate and holds it open. Only a close event or a close override command will close the gate.)
- **CLOSE** (closes the gate once)
- **CLOSE & HOLD** (closes the gate and holds it closed. Only an open event or an open override command will open the gate.)
- **AUX RELAY ON** (turns the auxiliary relay ON)
- **AUX RELAY OFF** (turns the auxiliary relay OFF)

Setting LEAF DELAY:

From the **SETTINGS** menu select the **LEAF DELAY**, then press **ENTER**.

- To select which leaf needs the delay press **ENTER** while the cursor blinks on the left side of **DELAY LEAF**. Cursor will then move to make selection, use **UP** button to toggle between **ONE/TWO** leaves, then press **ENTER** to save.
- Then, select **DELAY** and press **ENTER** to edit the delay. Cursor will then move to edit delay, use **UP/DOWN** buttons to set the delay (0.0 to 6.0 Sec). NOTE: This is only used on double gate.

NOTE: Leaf delay is for the open cycle of selected leaf. The close delay will be for the opposite of selected leaf.

Setting AUXILIARY RELAY:

From the **SETTINGS** menu select the **AUXILIARY RELAY**, then press **ENTER**. The Cursor is used to show selection.

- Using **UP/DOWN** buttons, select the function, then press **ENTER**.
- If **PRE-WARN SIGNAL** was not selected skip next step.
- If **PRE-WARN SIGNAL** was selected, the delay must be set. Use the **UP/DOWN** buttons to set the pre-warn delay, then press **ENTER** to save.

Functions that can be program to the Auxiliary relay:

PRE-WARN SIGNAL: This is used to turn on a strobe light or a siren with a delay before the gate starts to move)

MOVING SIGNAL: This will activate the relay and keep it active as the gate is in motion.

ALARM ALERT: This will activate the relay when the gate has been tempered with. Use as an alarm sensor output.

OPENED SIGNAL: This will keep the relay active while the gate is in the fully opened position.

CLOSED SIGNAL: This will keep the relay active while the gate is in the fully closed position.

NOTE: an asterisk will appear on selected function.

Setting SERVICE CYCLE:

From the **SETTINGS** menu select the **SERVICE CYCLE**, then press **ENTER**.

An on board cycle counter is integrated and can be used to program a service call. It can be set at a predetermine # of cycles.

- To set the number of cycles press **ENTER** button. The cursor will then move to the 0 on the ones position.
- Use the **RIGHT/LEFT** buttons to move cursor to other positions and the **UP/DOWN** buttons to increase/decrease values. Press **ENTER** button to save.

NOTE: If the service cycle is programmed, the board will start to count down every cycle and alert when the remaining cycles reach 0. The alert is the audible alarm that will beep every hour for 1 minute. If no service cycle was programmed, nothing happens.

SETTINGS MENU

Setting LIMIT SW CONFIGURATION:

From the SETTINGS menu select the **LIMIT SW CONF.**, then press **ENTER**.

- **INDEX:** It's used for speed control using its feedback. It's also used to keep track of gate position.
- **BEMF:** This is used for applications where the amount of conductors are limited and is difficult to run new wiring. Using this option only the limit switches will be used and the motor will not have speed control.
- To toggle **INDEX** and **BEMF** press the **ENTER** button to edit. Use the **UP/DOWN** buttons to toggle and press **ENTER** to save the setting.

Setting to DEFAULT:

From the SETTINGS menu select the **SET TO DEFAULT**, then press **ENTER**.

In this section the user is allowed to set the programming back to factory settings (factory default).

Use the **UP/DOWN** buttons to select the parameter that you would like to set back to factory default and press **ENTER**.

DEFAULT ALL will set every parameter back to factory settings.

This very useful when you are not sure what has been programmed.

DIAGNOSTICS MENU

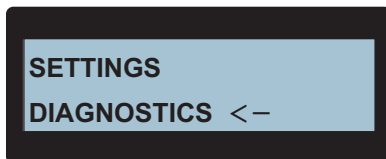

ENTERING THE DIAGNOSTICS MENU

If LCD display is not awake, press the **ENTER** button twice to wake up the display.

Press the < left button to select **ENGLISH**.

Using the **UP/DOWN** buttons select **DIAGNOSTICS**, then press **ENTER**. The < left button could be used to go back to previous screen.

Using the **UP/DOWN** buttons move to selection, then press **ENTER**.

- **GATE STATUS:** This displays the status of the gate (OPENING, CLOSING, OPENED, CLOSED, STOPPED or STOPPED ERD)
- **METER:** The meter will display Battery Voltage, LINE IN Voltage, Motor 1 current draw and Motor 2 current draw. Use the **UP/DOWN** buttons to scroll thru the different items.
- **MOTOR ONE:** This will display the motor one speed and position of the gate travel. Use the **UP/DOWN** to scroll to **SPEED** and **TRAVEL**.
- **MOTOR TWO:** This will display the motor two speed and position of the gate travel. Use the **UP/DOWN** to scroll to **SPEED** and **TRAVEL**.
- **EVENT LOG:** This is a very useful event log that displays up to 25 abnormal events with date and time stamp that are recorded as they happen. Use the **UP/DOWN** buttons to scroll thru the events.
- **CYCLE COUNT:** This will display the following cycle counts;

LIFE CYCLES

MONTH CYCLES

DAY CYCLES

SERVICE COUNT: This will show the **REMAINING CYCLES**.

This will only show if a service was programmed. An indication to reset will show when remaining cycles reach 0

MENU DESCRIPTION

<**ENG**>: English selection by pressing < left button.

ESP.>: Spanish selection by pressing > right button.

1. SETTINGS: Settings menu selection by pressing enter while settings is selected.

1.1 TIME & DATE: This menu is to edit/adjust time and date (including day of the week)

1.2 SPEED:

1.2.1 MAX SPEED: This is the maximum speed for the motor

1.2.2 ACCELERATION: This is the acceleration rate (range: slow, medium and fast).

1.2.3 SLOW/DOWN: This the percentage of travel where the motor will start slowing down as it approaches the limits.

1.3 POWER:

1.3.1 TORQUE: There are three levels of torque (Low, Med and high).

1.3.2 CURR. SENSE: Current sense is to select the way the board reads current from the load. Threshold (**THLD**) is default and is recommended for normal operation.

Progressive (**PRGV**) is for gates installed where wind is a factor.

1.4 7/DAY TIMER

1.4.1 EVENT 1: There are 10 programmable events.

1.4.2 EVENT ACT.: This is where the actions

is selected.

1.4.3 TIME: Time when the action takes place.

1.4.4 DAYS (ACTIVE): Days that require the the action to be active. Each day needs to be

turn on manually using the > right button to toggle ON/OFF.

1.5 LEAF DELAY

1.5.1 DELAY LEAF: This is for the leaf

selection.

1.5.2 DELAY: To set the delay of selected leaf.

1.6 AUXILIARY RELAY

1.6.1 RELAY ACTION: Selection of the action for the relay function.

These are the available actions.

1.6.1.1 OFF (INACTIVE)

1.6.1.2 PRE-WARN SIGNAL

1.6.1.2.1 DELAY

1.6.1.3 MOVING SIGNAL

On when gate is in motion.

1.6.1.4 ALARM SIGNAL

On when tempered with operator.

1.6.1.5 OPENED SIGNAL

On when gate fully open.

1.6.1.6 CLOSED SIGNAL

On when gate fully closed.

1.7 SERVICE CYCLE

1.7.1 SERVICE CYCLE COUNT: This is used to program a service call. You set the number of cycles you want the gate to run before the customer gives you a call. The audible alarm will notify the end user with double beep when it's time for the service call.

1.8 LIMIT SW CONF.

1.8.1 INDEX: This is the default configuration. it uses a hall effect sensor for speed control and to keep track of the gate position.

1.8.2 BEMF: This is an option to run only on limit switches. NOTE: Not fully functional yet

1.9 SET TO DEFAULT

1.9.1 DEFAULT ALL: This selection will set all parameters to factory settings.

1.9.2 DEFAULT SPEED

1.9.3 DEFAULT POWER

1.9.4 DEFAULT 7/D TMR

1.9.5 DEFAULT LEAF DLY

1.9.6 DEFAULT RLY FUNC

1.9.7 DEFAULT SVC C

1.9.8 DEFAULT SW CONF.

2. DIAGNOSTICS: Diagnostics menu selection by pressing enter while diagnostics is selected.

2.1 GATE STATUS

2.2 METER

2.3 MOTOR ONE

2.4 MOTOR TWO

2.5 EVENT LOG

2.6 CYCLE COUNT

ELECTRICAL CONNECTION

OPERATORS MUST BE PROPERLY GROUNDED!

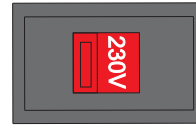
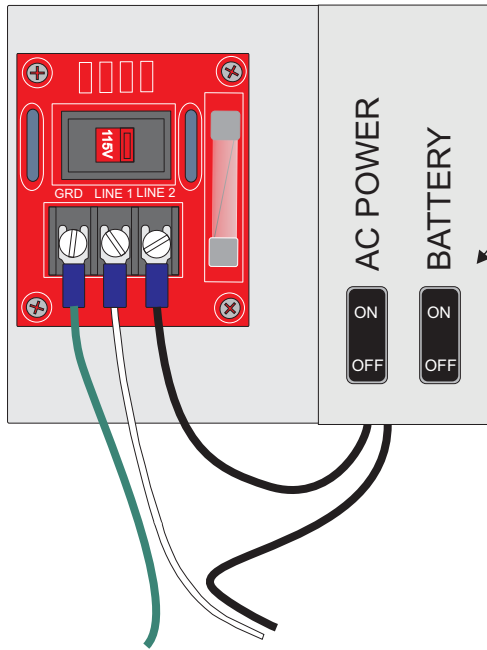

NOTE: When applying 230V to operator make sure voltage switch is flipped to 230V position.

Power connection	115VAC	220VAC Single Phase
LINE 1 =	115V HOT	220V LINE 1
LINE 2 =	115V N	220V LINE 2

GND Connect to ground. Use a proper **ground rod** for a ground reference.

Use the shortest and thickest wire possible for ground.

For power, a minimum of a **20-Amp** dedicated circuit breaker is needed.

For power wire enclosure use UL listed conduits.

All gate operators **MUST** be properly grounded.

A proper ground in a gate operator installation minimizes or prevents damage from an electrical charge, such as a near lightning strike or an electrical static discharge.

Use a single wire for the ground. **DO NOT** splice two wires for the ground. If the wire breaks or is cut, replace it with a single length. **NEVER** use two wires for the ground.

Check with your City code for proper earth ground rod type and proper grounding procedures.

SWINGER LOOP LAYOUT

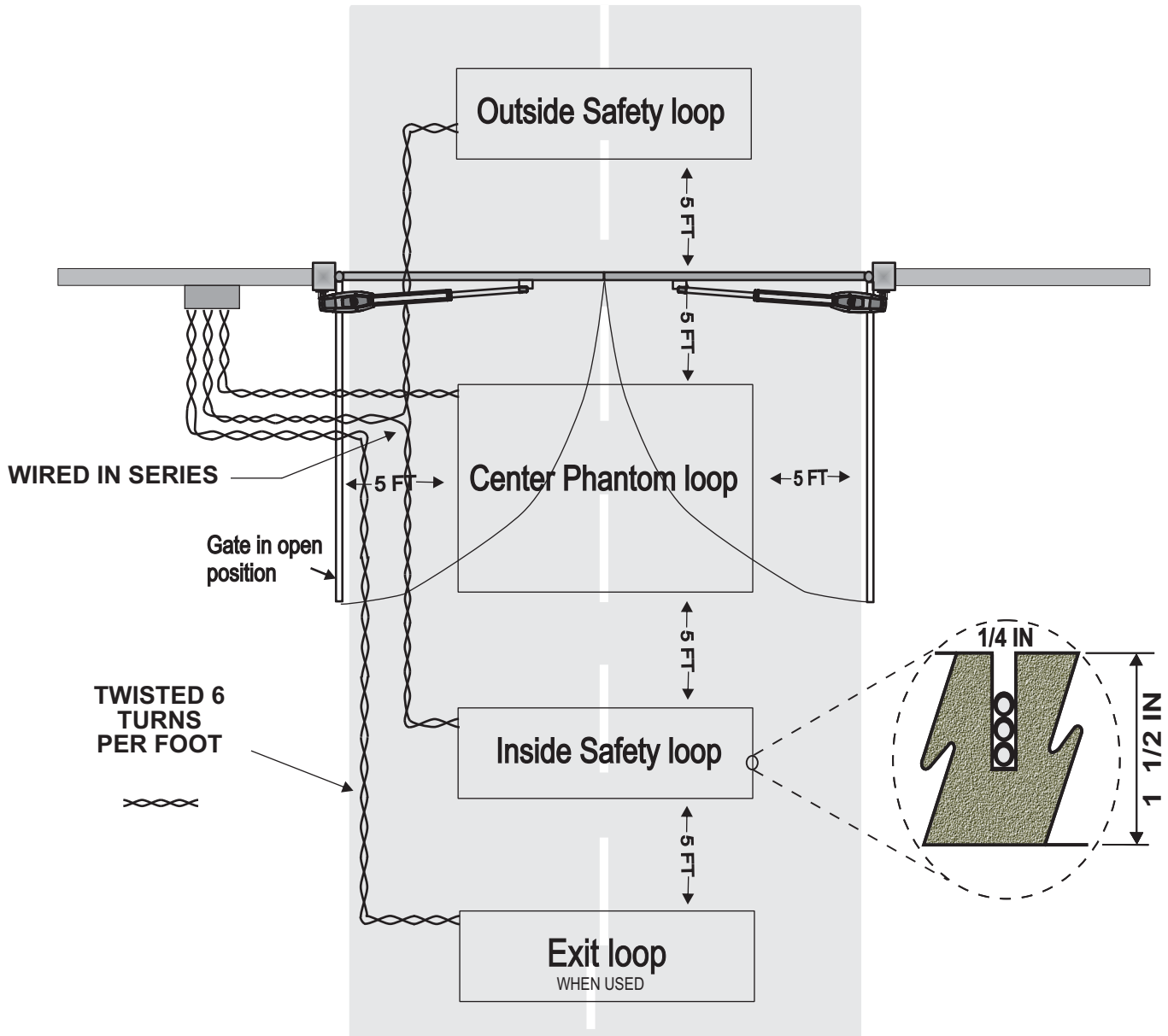

This is a normal loop layout. Remember when connecting to an All-O-Matic circuit board you use the normally closed contacts (N.C.) from the safety loop detector and normally open contacts from the exit and phantom loop detectors. You must twist the loop wires from the exit point of the saw cut of each loop all the way to the loop rack, no exceptions.

The TORO 24 control box includes the plug-in loop rack for EXIT, PHANTOM and SAFETY (reverse) loop detectors.

GENERAL LOOP INSTALLATION GUIDELINES

The following loop installation guidelines are for installing typical driveway loops for access control applications (i.e. parking gates, sliding gates, swing gates etc...) Always consult with loop detector manufacturers for specific equipment guidelines. This will confirm that the proper configuration and installation techniques are applied for your application.

Useful information about inductive loops:

- A. The typical sensing height is 2/3 of the shortest leg of loop (in feet)
Therefore a 4' x 8' loop typically has a detection height of 2.6'.
- B. The inductance of a conventional four-side loop can be estimated using the formula:

$$L = P \times (T^2 + T) / 4$$

Where L = Loop Inductance in microHenries

P = Loop Perimeter in feet

T = Number of turns of wire in saw slot

Therefore a 4' x 8' loop with 3 turns would be:

$$L = (4 + 8 + 4 + 8) \times (3^2 + 3) / 4$$

$$L = 24 \times (9 + 3) / 4$$

$$L = 24 \times 12 / 4$$

$$L = 24 \times 3$$

$$L = 72 \text{ microHenries}$$

Suggested guidelines for loop installation:

Loop wires should be twisted 6 turns per foot, and twisted from saw slot to the detector. If possible start twisting the wires from the edge of the loop.

All 90 degree corners should be chamfered so that the course of the wire does not change direction sharply but rather at shallower angles of 45 degrees or less. Core drilling of the corners achieves the same effect but can still lead to failure due to sharp edges remaining in the corner area.

Loop Perimeter	# of Turns
6' - 12'	6
13' - 20'	5
21' - 60'	4
61' - 240"	3
241 & Up	2

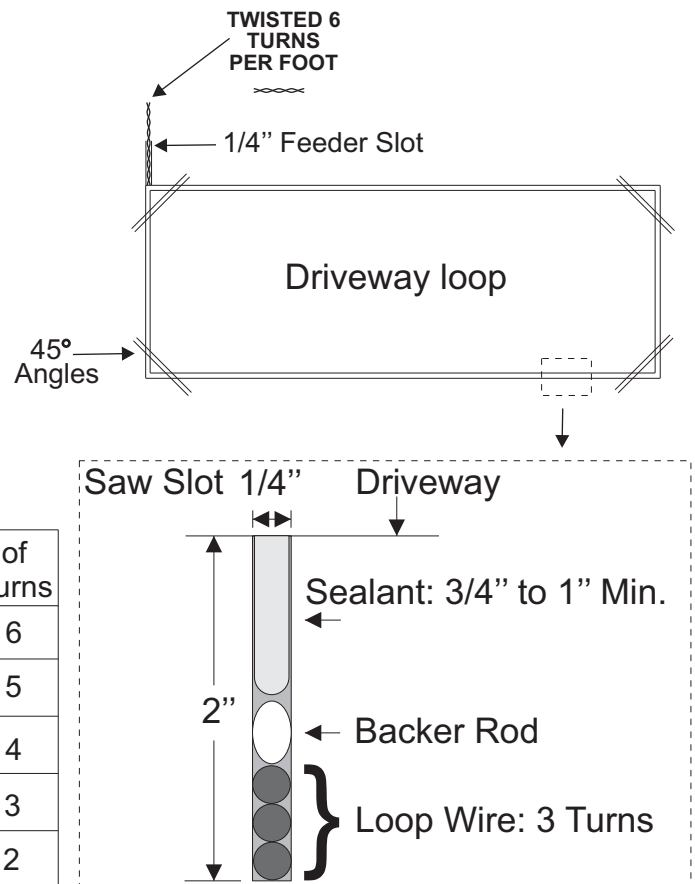

ENTRAPMENT PROTECTION INSTALLATION FOR SWINGING GATES

A minimum of two monitored entrapment protection devices are **required** for each entrapment zone. All locations or point of contact where a person can become entrapped between a moving gate and a rigid object is considered an entrapment zone. The operator has an inherent entrapment protection (**ERD**) system. It requires an external monitored entrapment protection device (contact edge sensor or non-contact photoelectric sensor) for each entrapment zone prior to gate operation. The operator cycles power to the external entrapment protection device and checks for device signals. If the operator does not receive the correct feedback from the device, the gate will not operate.

Below are some samples of entrapment zones and where the entrapment protection devices should be installed.

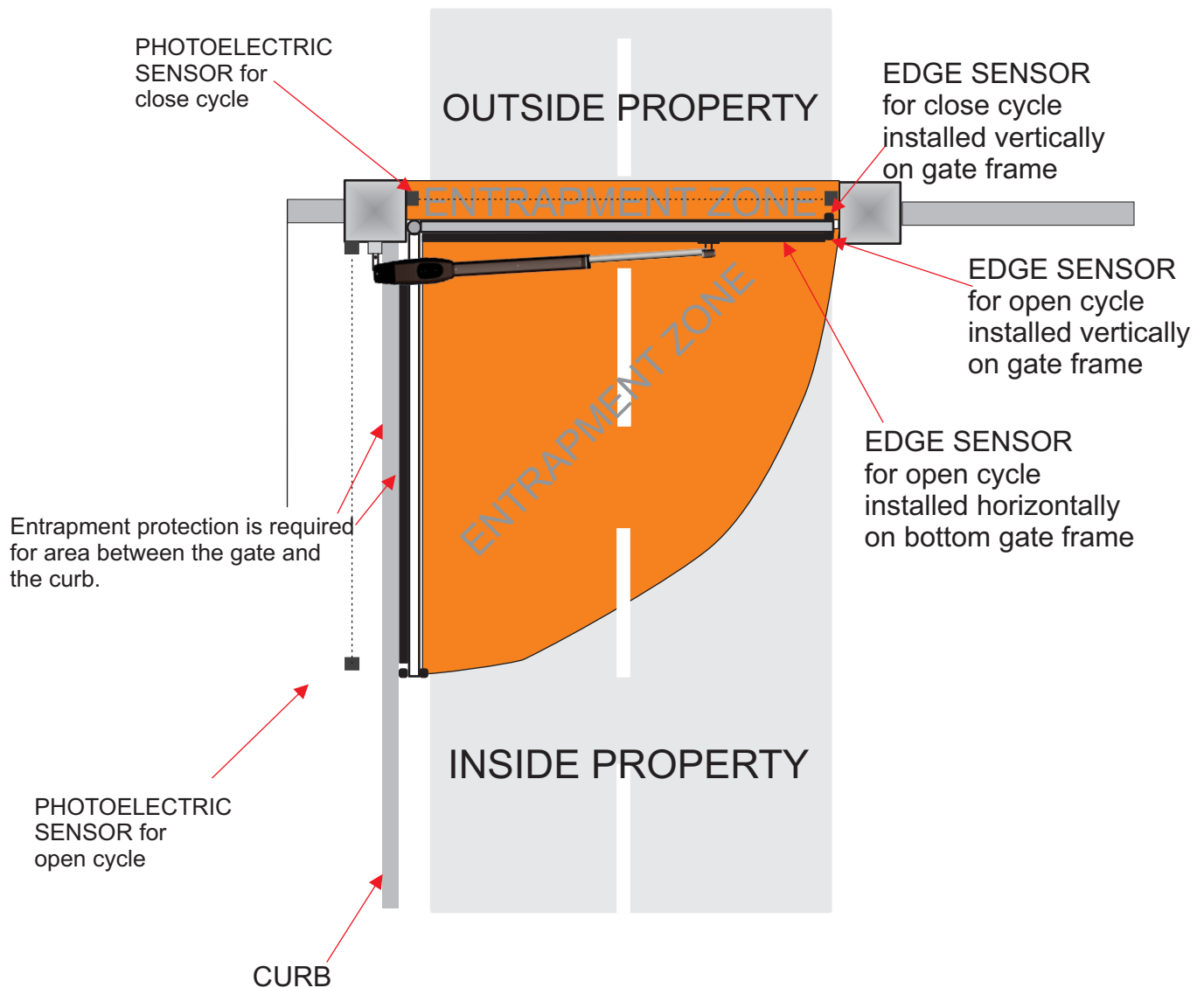

ENTRAPMENT PROTECTION DEVICE CONNECTIONS

There are two type of entrapment protection devices that can be connected to the operator, NON-CONTACT SENSOR (PHOTO EYE) and CONTACT SENSOR (EDGE SENSORS). These inputs are for monitored ENTRAPMENT PROTECTION devices.

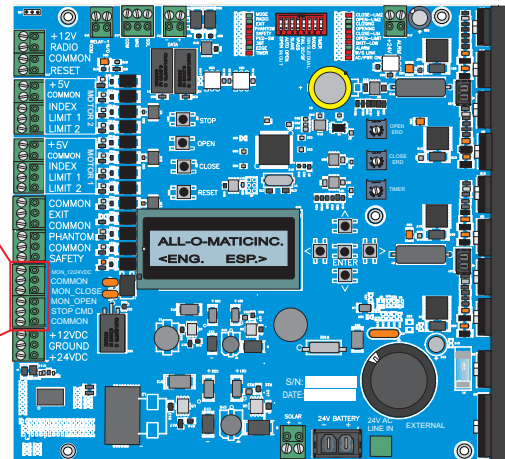
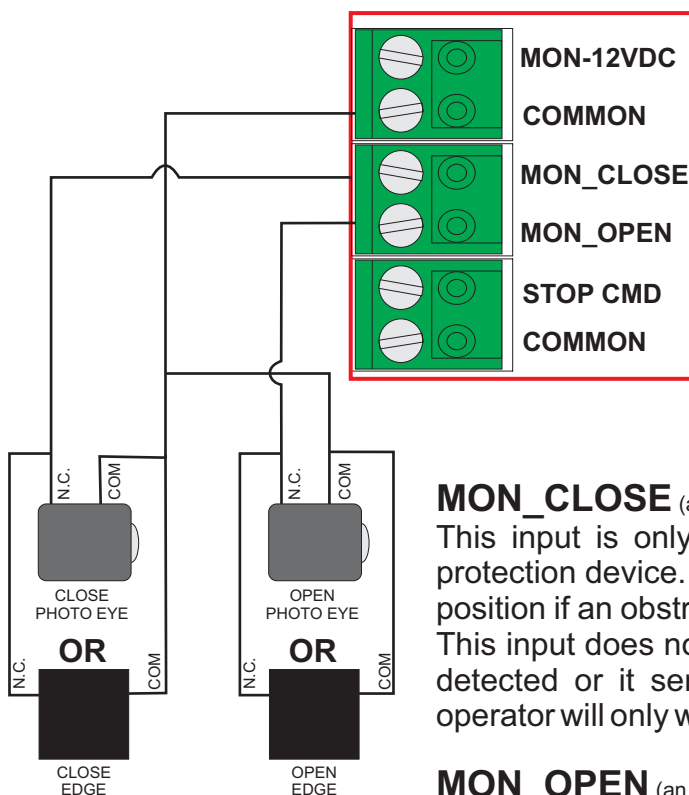

PCB model: T24PCB

MON_CLOSE (an LED will indicate when an obstruction is detected or device not present)
This input is only for the close direction monitored entrapment protection device. When gate is closing it will open to the full open position if an obstruction is sensed and resets the auto close timer. This input does nothing in the opening direction. If a device is not detected or it senses a fault (**MON_FAULT** LED will turn ON), the operator will only work on constant pressure actuated switch.

MON_OPEN (an LED will indicate when an obstruction is detected or device not present)
This input is only for the open direction monitored entrapment protection device. When gate is opening it will reverse 2 seconds and stop if an obstruction is sensed. This input does nothing in the closing direction. On power up, if a device presence is not detected the operator will assume one is not required for opening direction. If a device is connected and board detects a fault (**MON_FAULT** LED will turn ON), the operator will only work on constant pressure actuated switch.

Monitored entrapment protection devices use four wires to connect to the board. From the device, connect **relay common** to board **COMMON** and **N.C.** relay contact to assigned **MON_OPEN** or **MON_CLOSE** input. Connect the power wires to the **COMMON** and **MON-12VDC**. **VERY IMPORTANT:** The **MON-12VDC** supply must be used (not the normal 12VDC terminal) to properly monitor entrapment protection devices.

Refer to the device manufacturer wiring instructions for details. Be sure to follow the **N.C.** directions. Some devices may work on different monitoring interfaces as well as the **N.C.**.

Should there be a need for more than one entrapment protection device for each direction, a multi-input module from Miller Edge Model: MIM-62 (not included) may be used .

ACCESSORY CONNECTIONS

The circuit board 12 or 24VDC output provides up to 500 mAmps each of power for accessories. More than two or three accessories will require a separate power supply.

NOTE: 12 or 24VDC Accessories only.

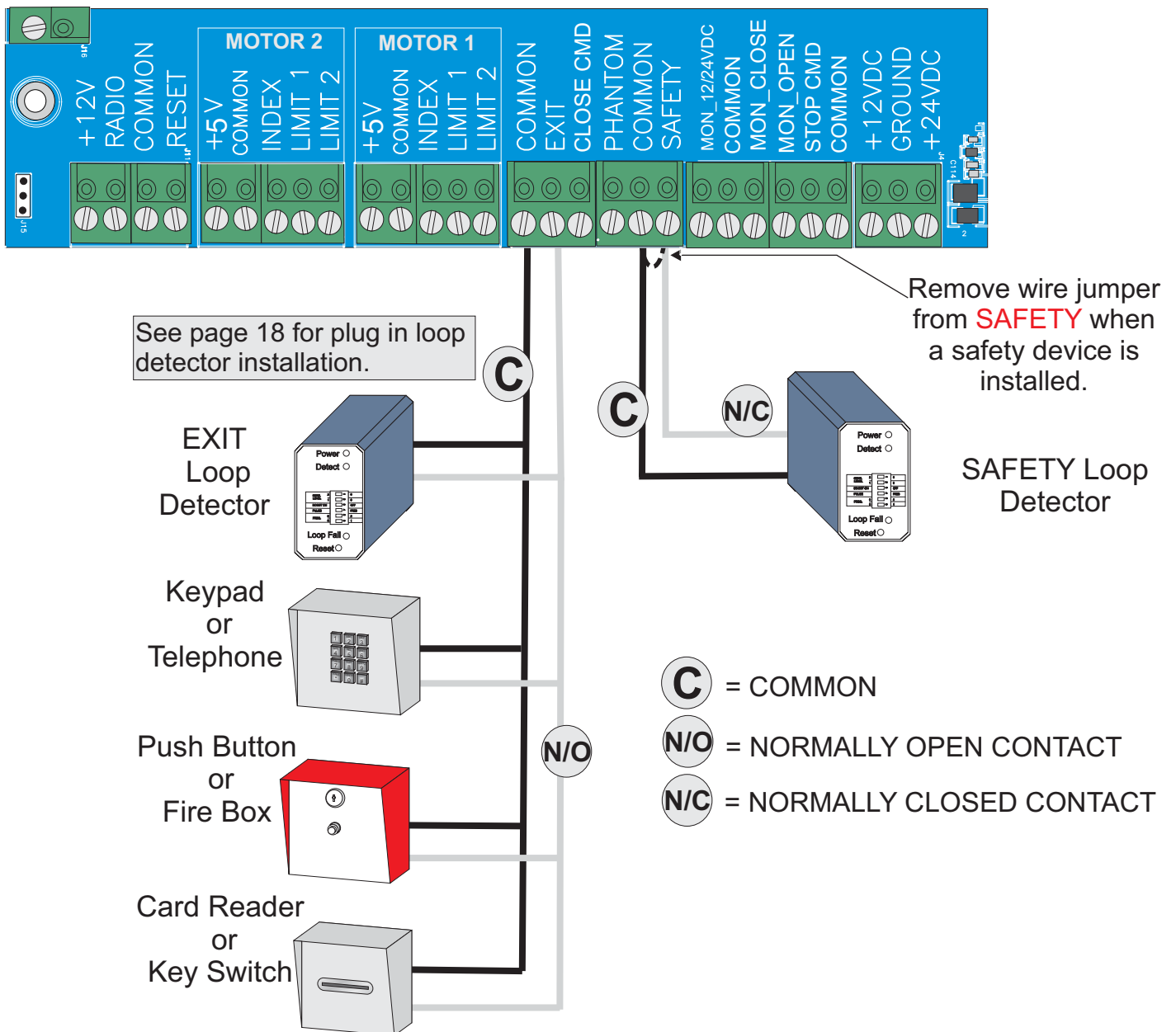

LPR-1 LOOP RACK INSTALLATION

This is a **typical** loop configuration for a gated driveway. Remember when connecting to an All-O-Matic circuit board the safety (reverse) uses **normally closed contacts** from the loop detector, the wire jumper from the safety connector needs to be removed when a safety loop is installed.

You must twist your wires from your exit point of the saw cut all the way to the loop detectors, no exceptions.

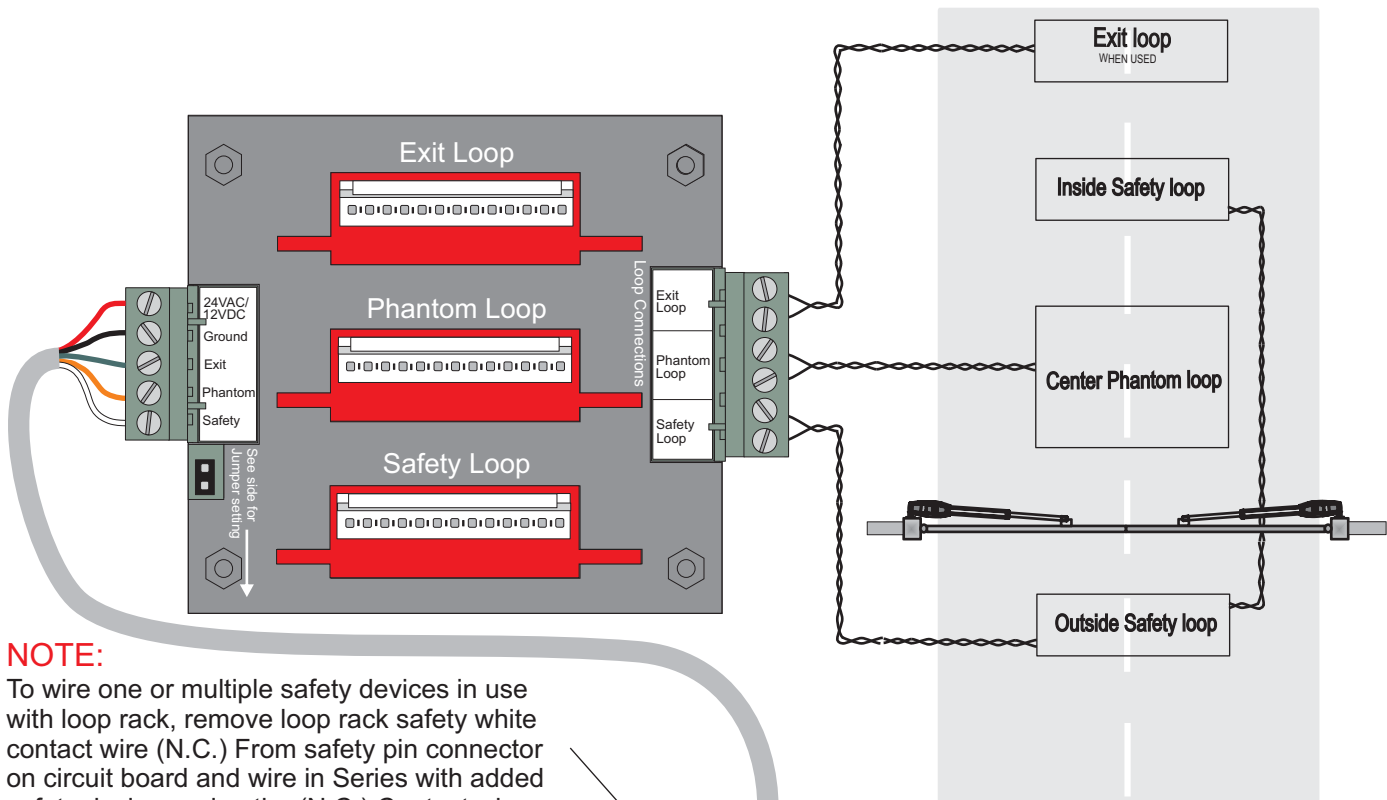

NOTE:

To wire one or multiple safety devices in use with loop rack, remove loop rack safety white contact wire (N.C.) From safety pin connector on circuit board and wire in Series with added safety devices using the (N.C.) Contact wire from your safety device in the safety contact. (see page 16)

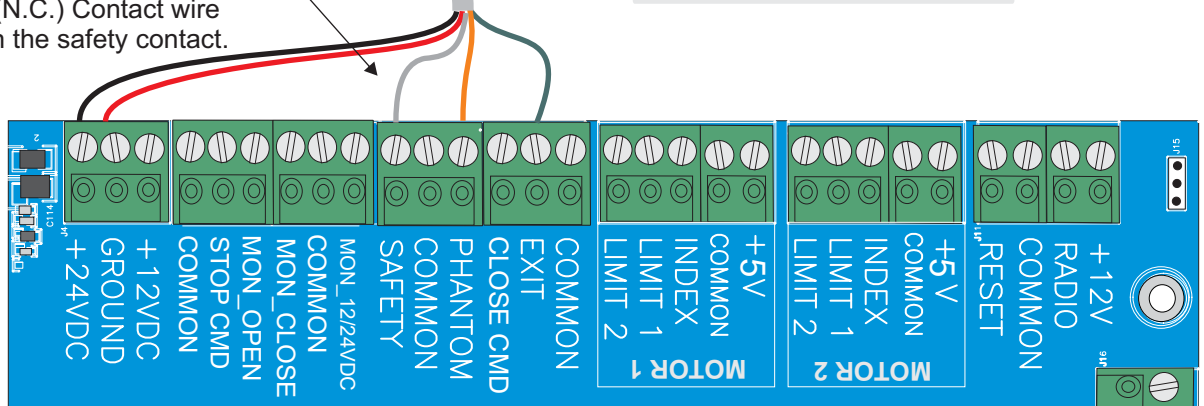

Compatible Detectors

Brand	Model No.	Jumper setting
Reno A&E	H2	<input type="checkbox"/> OFF
EDI	LMA-1800-LP	<input type="checkbox"/> OFF
Diablo Controls	DSP-40S	<input checked="" type="checkbox"/> ON
Elite	AELD	<input type="checkbox"/> OFF
NorthStar	NP2-ES	<input checked="" type="checkbox"/> ON

THREE BUTTON STATION SYSTEM

See push button connections below.

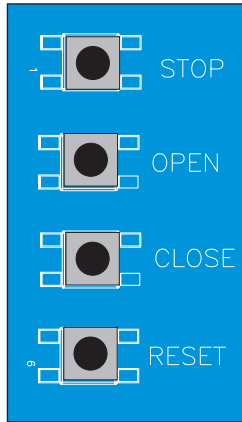

A three button station was integrated on the board to make adjustments easier when setting limit switches and adjusting ERDs.

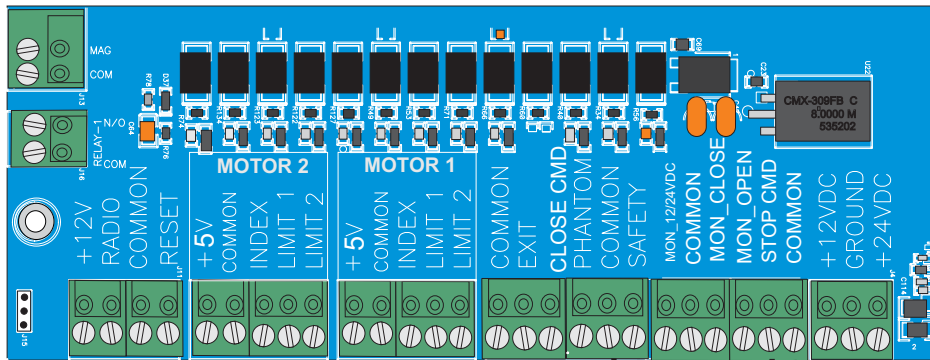

Connect the **COMMON** from all the push buttons to **COMMON** input on the board.

Connect **OPEN** push button **N.O.** contact to **EXIT** input on the board.

Connect **CLOSE** push button **N.O.** contact to **3BT** input on the board.

Connect **STOP** push button **N.C.** Contact to **PED-SW** input on the board and remove **PED-SW** jumper.

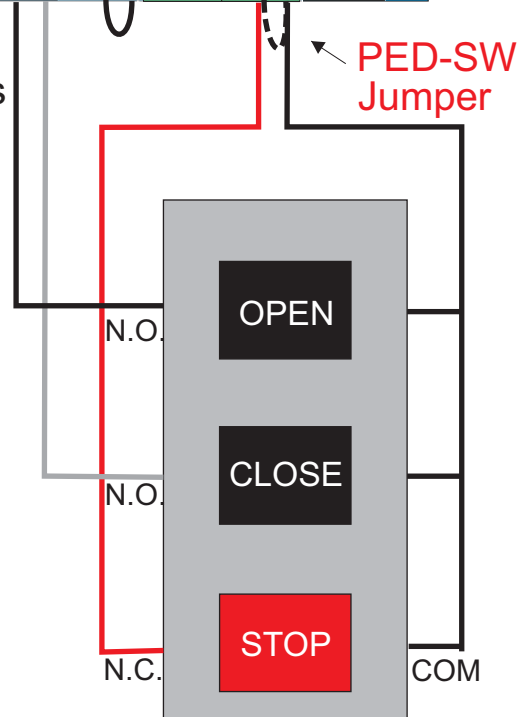

MAGNETIC/SOLENOID LOCK CONNECTION

Magnetic lock installation requires a step down transformer with appropriate voltage for the specific lock accessory. Operator will provide a 120VAC outlet for the step down transformer.

Connections: Plug the lock device transformer to the 120VAC outlet plug.

For Magnetic lock: Connect one wire from transformer directly to one wire of the magnetic lock, the other wire from transformer will be connected to the relay plug **COM** input and the **MAG** relay output connects to the other wire of the magnetic lock. See illustration below.

For Solenoid lock: Connect one wire from transformer directly to one wire of the solenoid lock, connect the other wire from transformer to the relay plug **COM** input and the **SOL** relay output

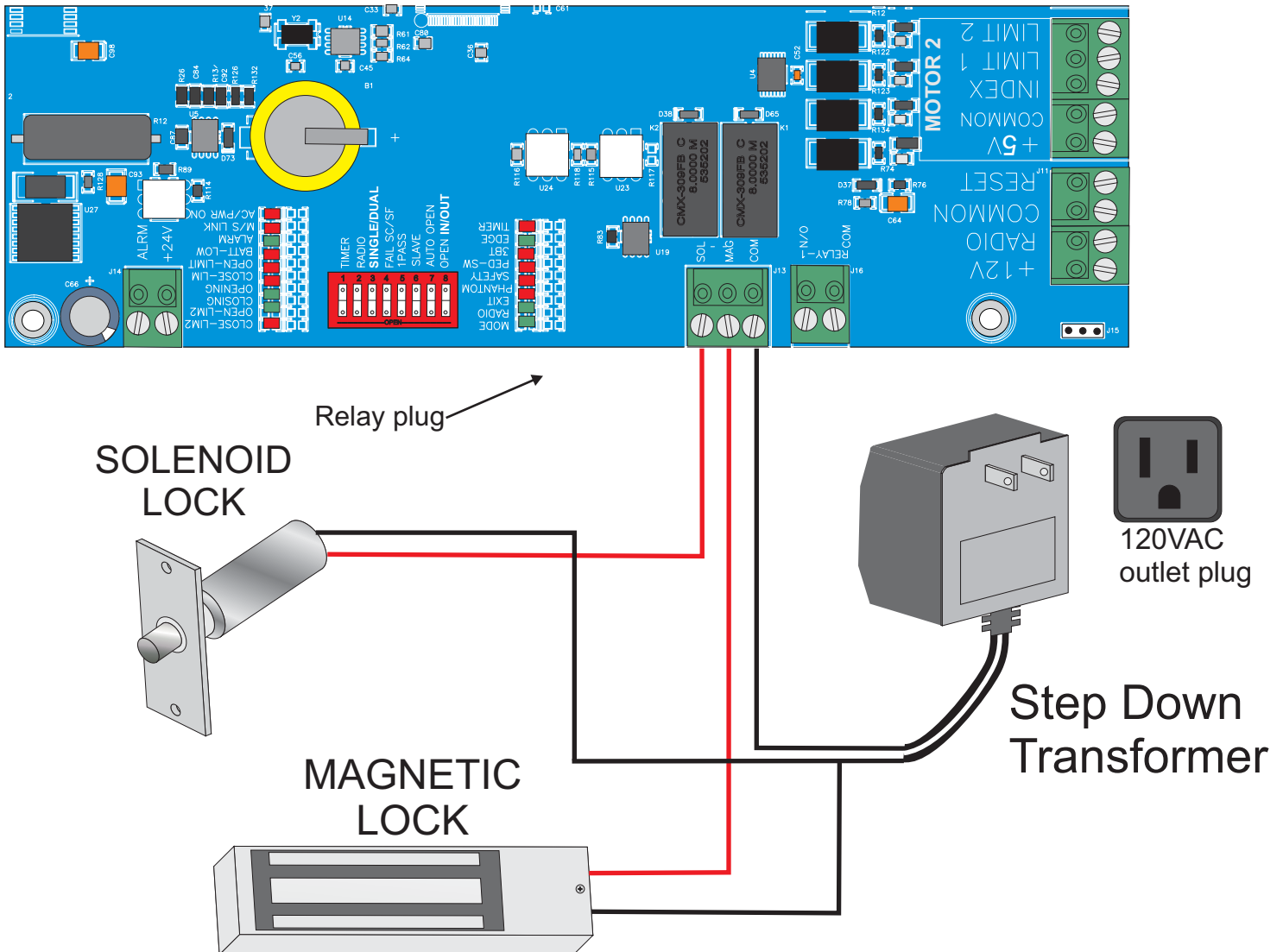

RADIO RECEIVER CONNECTIONS

4 wire receiver: connect the two relay wires to common and radio terminals.

4 wire receiver: connect the two relay wires to common and radio terminals. Black (negative) wire to common and red (positive) wire to +12/24V terminal.

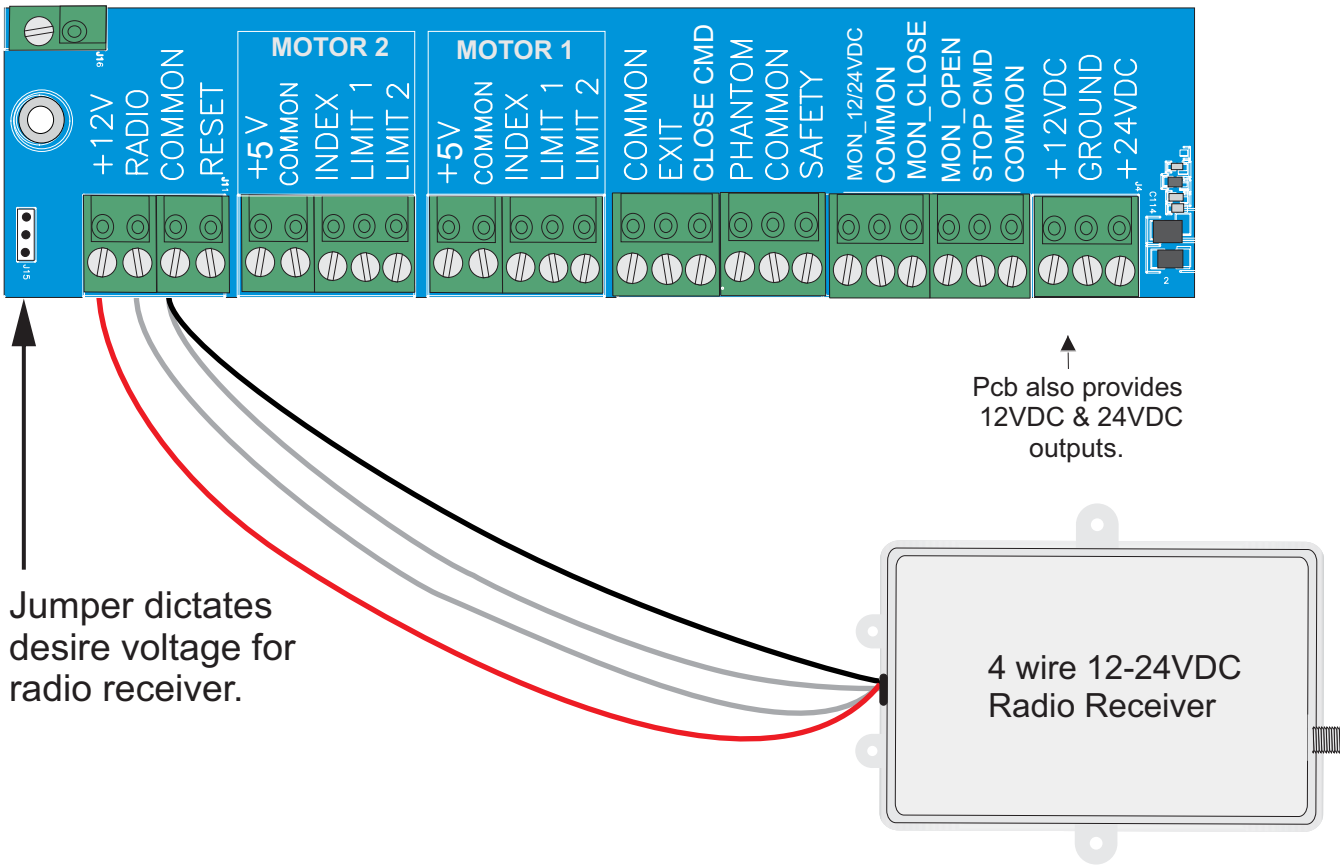

OPEN AND CLOSE OBSTRUCTION SENSITIVITY ADJUSTMENT (ERD)



ERD'S must be adjusted by qualified technician.

The gate operator ERDs must be adjusted so that the gate provides regular, reliable and safe operation.

When gate stops and reverses by itself, the ERD is **too sensitive**.

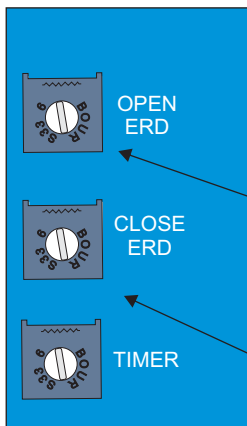
The gate must stop and reverse when it hits an obstruction or the ERD is **not sensitive enough**.



 Counter clockwise maximum sensitivity
 Clockwise minimum sensitivity

ERD must be checked every six months.

TIMER ADJUSTMENT

TIMER ON: Timer to close, can be set from 1 to 60 seconds.

TIMER OFF: Gate operation is push button to open, push button to close.

TO OVERRIDE THE TIMER: Turn the RADIO switch to the "ON" position. This will allow the radio receiver to close the gate before the timer.

TIMER ADJUSTMENT

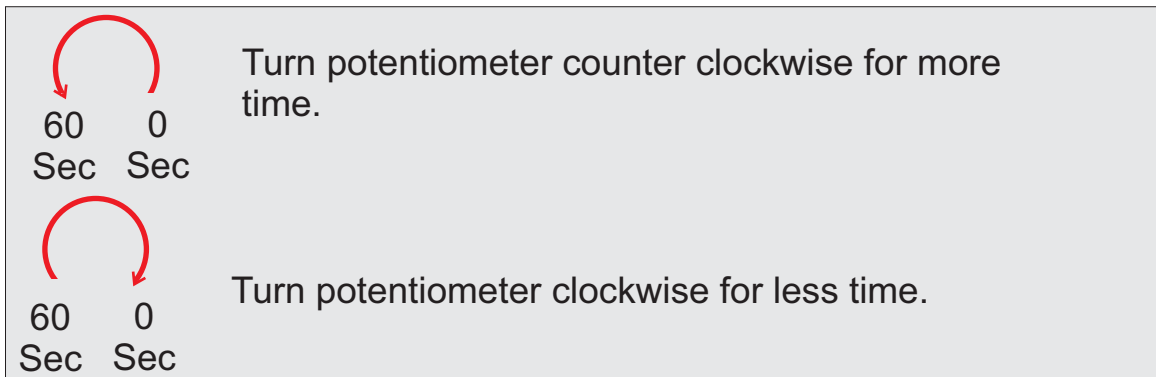

Turn potentiometer counter clockwise for more time.

Turn potentiometer clockwise for less time.

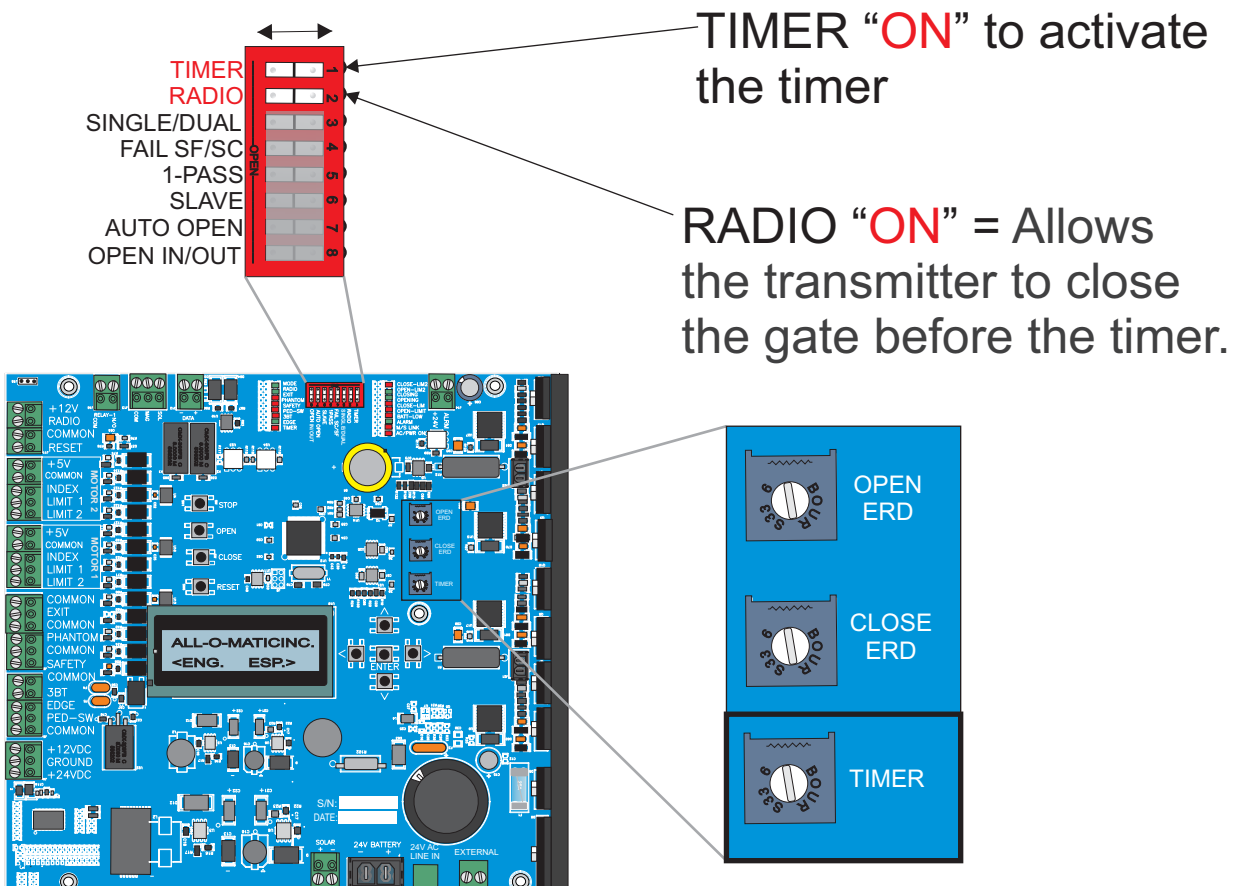

TIMER "ON" to activate the timer

RADIO "ON" = Allows the transmitter to close the gate before the timer.

OPEN ERD

CLOSE ERD

TIMER

DIP SWITCH FUNCTIONS

NOTE: Any changes to dip switches while power is **ON** requires you to reset the processor in order for board to read the change.

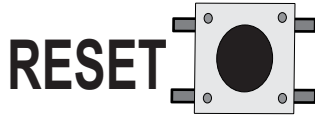

RESET

TIMER
RADIO
SINGLE/DUAL
FAIL SF/SC
1-PASS
SLAVE
AUTO OPEN
OPEN IN/OUT

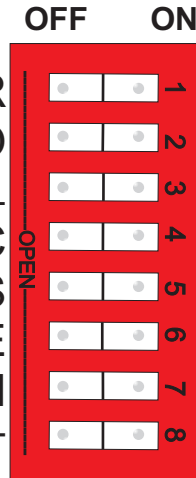

TIMER

TIMER switch “**ON**” activates the **TIMER**. See page 22 for details

RADIO

RADIO switch “**ON**” allows the radio receiver to override the timer. See page 22 for details.

SINGLE/DUAL

This switch is used to select single or dual motor operation. **OFF** will only run motor 1 and **ON** will run motor 1 and motor 2.

FAIL SF/SC

This is to set the operator as fail-safe or fail secure. **ON** for **Fail-safe**: on power failure, board will monitor battery voltage to make sure gate opens before battery drains out completely. **OFF** for **Fail-secure**: on power failure gate will run until battery is low and stay close.

1-PASS

This is a true one pass, anti-tailgating feature. This feature may only be used with safety loops. With this switch in the “**ON**” position, the gate will open until one car passes the safety loops then it will stop and close. If a second car pulls on the loop the gate will stop the car must then back off the loop before the gate will close.

SLAVE

This feature is used on master/slave setups. Set slave switch “**ON**” on slave machine, all other switches “**OFF**”. Set slave switch to the “**OFF**” position on master machine. Set other function switches on master machine as desired. **NOTE:** this function is not used on the TORO 24.

AUTO OPEN

This feature is to automatic open the gate on power interruption. It is a very particular feature used in areas where the fire department requires the gate to open automatically after a power outage. Set this dip switch “**ON**” when this feature is desire.

OPEN IN/OUT

This feature is to set the opening direction. **OFF** is to open in and **ON** to open out.

SOLAR PANEL CONNECTIONS

The solar panel input will take a 12 or 24VDC panel or two 12VDC panels wired in series to make 24VDC. The on-board charger is limited to 80 watts. For applications that require more than 80 watts an external charger is required. See diagrams below for the different connection options.

NOTE: For information on solar panel calculation call ALL-O-MATIC or your local distributor for Assistance.

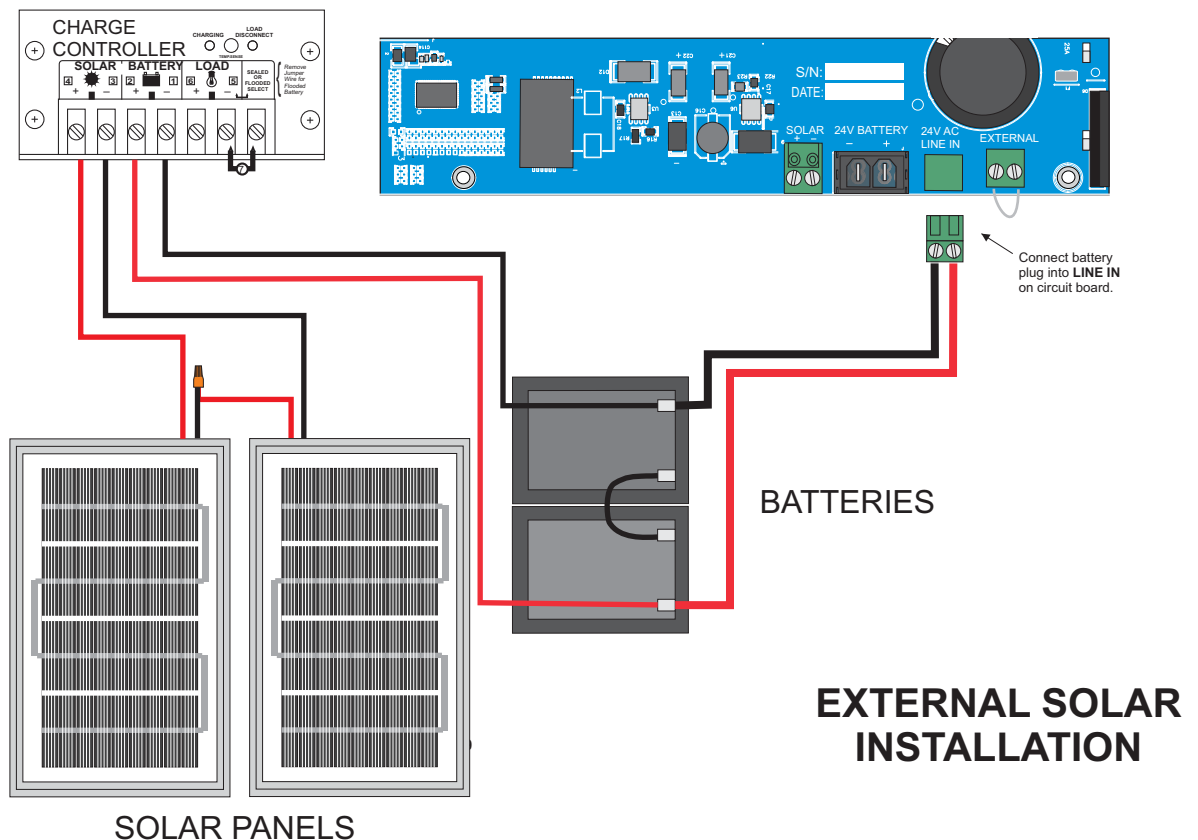
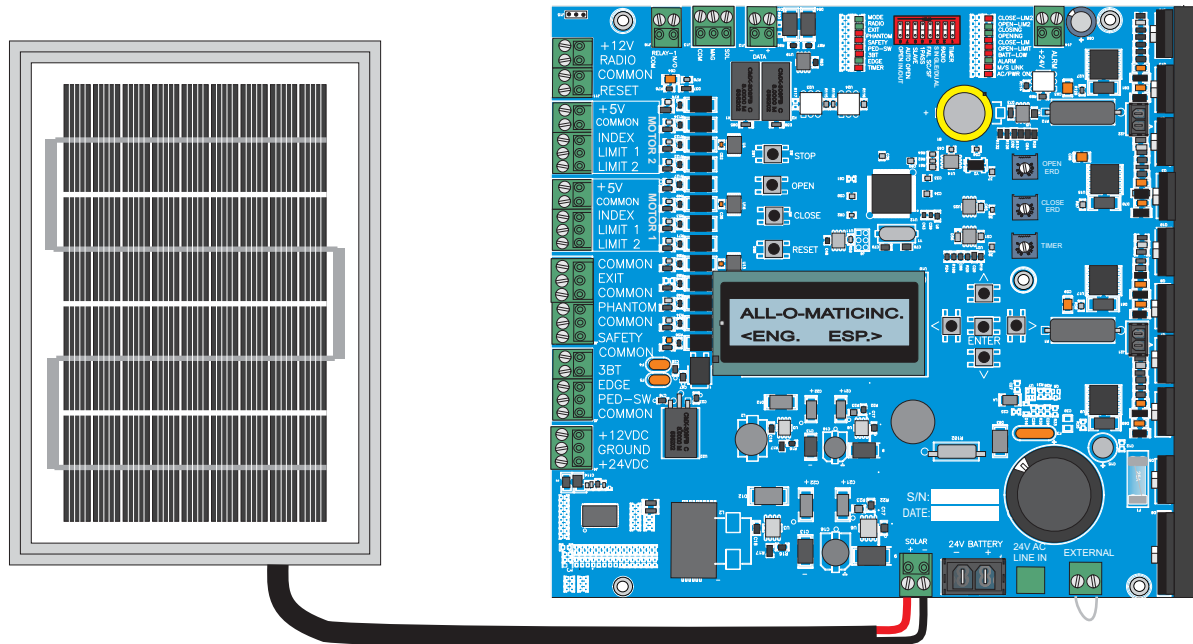

LED DIAGNOSTICS

AC/PWR ON: Will be lit when power is present at LINE-IN power input.

ALARM: Two states;

1st state: LED will blink (horn will beep also) every 30 seconds when battery is low, bad or disconnected.

2nd state: LED will turn on for 5 minutes when operator goes into shut down mode do to the gate hitting an obstruction (E.R.D.). Also, the horn will go off for 5 minutes.

LOW BATTERY: LED will be on solid when battery is low.

MODE: Two states:

1st state: LED will blink slow (about every 2 seconds) when an overload occurs (over current).

2nd state: LED will blink fast (about every ½ second) when gate is jammed or motor sensors are not responding or disconnected.

OPEN LIM: LED will be on while the open limit switch on MOTOR 1 is active.

OPEN LIM2: LED will be on while the open limit switch on MOTOR 2 is active.

CLOSE LIM: LED will be on while the close limit switch on MOTOR 1 is active.

CLOSE LIM2: LED will be on while the close limit switch on MOTOR 2 is active.

OPENING: LED will be on while the board is sending power to either MOTOR 1 and/or MOTOR 2 for opening direction.

CLOSING: LED will be on while the board is sending power to either MOTOR 1 and/or MOTOR 2 for closing direction.

RADIO: LED will be on while radio input is activated (closed circuit to common).

EXIT: LED will be on while exit input or OPEN push button are activated (closed circuit to common).

PHANTOM: LED will be on while phantom input is activated (closed circuit to common).

SAFETY: LED will be on while safety input is activated (circuit is open from common).

PED-SW: LED will be on while ped-sw input is activated (circuit is open from common).

3BT: LED will be on while 3bt input or CLOSE push button are activated (closed circuit to common).

EDGE: LED will be on while edge input is activated (closed circuit to common).

TIMER LED: LED will blink when timer is counting down (on the open position only).

M/S LINK: This is only for Master/Slave set up. Since this board is capable of running two motors is not been used.

ITEM NO.	QTY.	PART NUMBER	ITEM NO.	QTY.	PART NUMBER
1	1	T24-001, REV 17, MAIN HEAD HOUSING, BOTTOM	41	3	HX-SHCS 0.25-20x0.75x0.75-S
2	1	T24-002, REV 17, MAIN HEAD HOUSING, TOP	42	16	Hi Collar LW 0.25
3	1	T24-003, REV 4, COVER, HOUSING ELECTRICAL	43	8	Hi Collar LW 0.138
4	1	T24-004, REV 4, MOTOR BRACKET	44	3	HX-SHCS 0.138-32x0.4375x0.4375-N
5	1	T24-005, REV 2, DRIVE ADAPTER	45	3	B18.3.5M - 5 x 0.8 x 12 Socket FCHS - 12N
6	2	T24-006, REV 1, MITER GEAR, 10 PITCH, 20 TEETH	46	1	HX-SHCS 0.164-32x0.75x0.75-S
7	1	T24-007, REV 4, GEARBOX SHAFT	47	1	Hi Collar LW 0.164
8	1	T24-008, REV 3, WORM GEAR			
9	1	T24-009, REV 2, GEARBOX RELEASE PIN			
10	1	T24-010, REV 1, GEARBOX RELEASE KEY			
11	1	T24-011, REV 2, BRONZE BEARING			
12	1	T24-012, REV 1, WORM			
13	1	T24-013, REV 1, GEARBOX RELEASE PIN			
14	1	T24-014, REV 2, SPACER, DRIVE ADAPTER			
15	2	T24-015, REV 1, SPACER, DRIVE ADAPTER, MITER GEAR			
16	1	T24-016, REV 1, GEARBOX RELEASE SPRING			
17	2	T24-017, REV 1, BEARING CLAMP, 6203 BEARING			
18	1	T24-018, REV 2, BEARING CLAMP, 6202 BEARING			
19	1	T24-019, REV 4, BEARING CLAMP			
20	1	T24-020, REV 3, CAM PIVOT			
21	1	T24-021, REV 4, GEAR LEVER CAM			
22	1	T24-022, REV 1, LOCK BOLT			
23	1	T24-023, REV 9, HANDLE			
24	1	T24-024, REV 3, CAP, LOCK			
25	1	T24-042, REV 1, LEVER COVER			
26	2	5972K440_BALL BEARING			
27	1	MOTOR, 64110			
28	1	91590A126_STAINLESS STEEL EXTERNAL RETAINING RING			
29	1	91590A128_STAINLESS STEEL EXTERNAL RETAINING RING			
30	1	5972K357_BALL BEARING			
31	1	91585A448_METRIC 18-8 STAINLESS STEEL DOWEL PIN			
32	2	98490A160_METRIC STEEL WOODRUFF KEY			
33	1	90967A180_STAINLESS STEEL EXTERNAL RETAINING RING			
34	1	heyco-m4340			
35	1	heyco-m9134-m9135			
36	1	91590A125_STAINLESS STEEL EXTERNAL RETAINING RING			
37	1	E2005, REV 2, LOCK CYLINDER			
38	14	HX-SHCS 0.25-20x1x1-S			
39	1	CR-PHMS 0.138-32x0.375x0.375-N			
40	2	CR-PHMS 0.138-32x0.4375x0.4375-S			

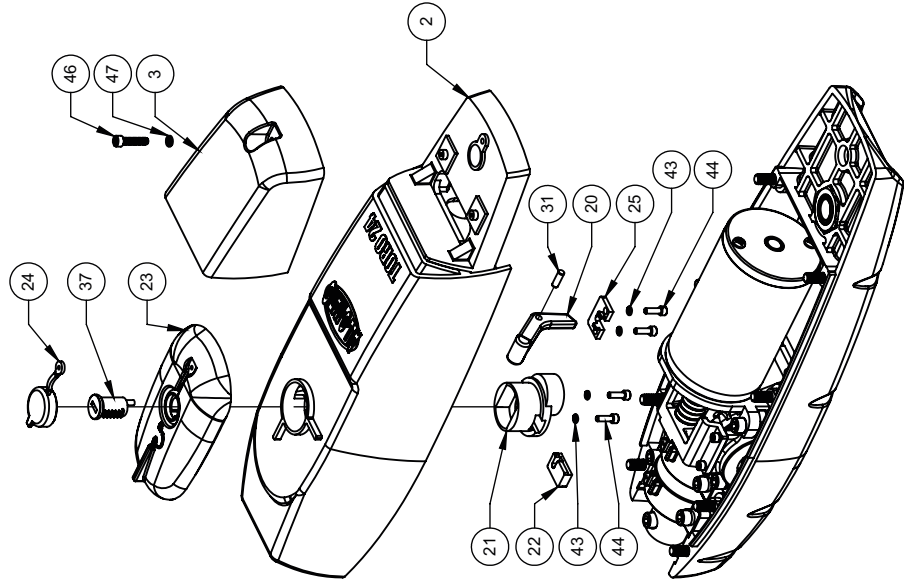

ALL-O-MATIC, Inc.

DIMENSIONS ARE IN MILLIMETERS
BREAK SHARP EDGES 10-40
MACHINED SURFACE FINISH IS
AS SHOWN UNLESS OTHERWISE NOTED
DO NOT SCALE DRAWING

THE INFORMATION DISCLOSED HEREIN WAS ORIGINATED BY
AND IS THE PROPERTY OF ALL-O-MATIC, INC. AND ALL PATENT,
TRADEMARK AND COPYRIGHT RIGHTS THEREOF ARE RESERVED BY
ALL-O-MATIC, INC.

DRAWN BY: FTA
CHECKED: X
DATE: 1/27/19
RAW MAT.

TITLE: MAIN HOUSING ASSY
DRAWING SEE: B
SCALE: 1:3
SHEET 1 OF 3
PART#: T24-025

1/27/19 DATE
FTA BY: X
ENGINEERING CHANGE ORDER DESCRIPTION

1 SYMBOL E20# PROTOTYPE RELEASE
1/27/19 DATE
FTA BY: X
ENGINEERING CHANGE ORDER DESCRIPTION

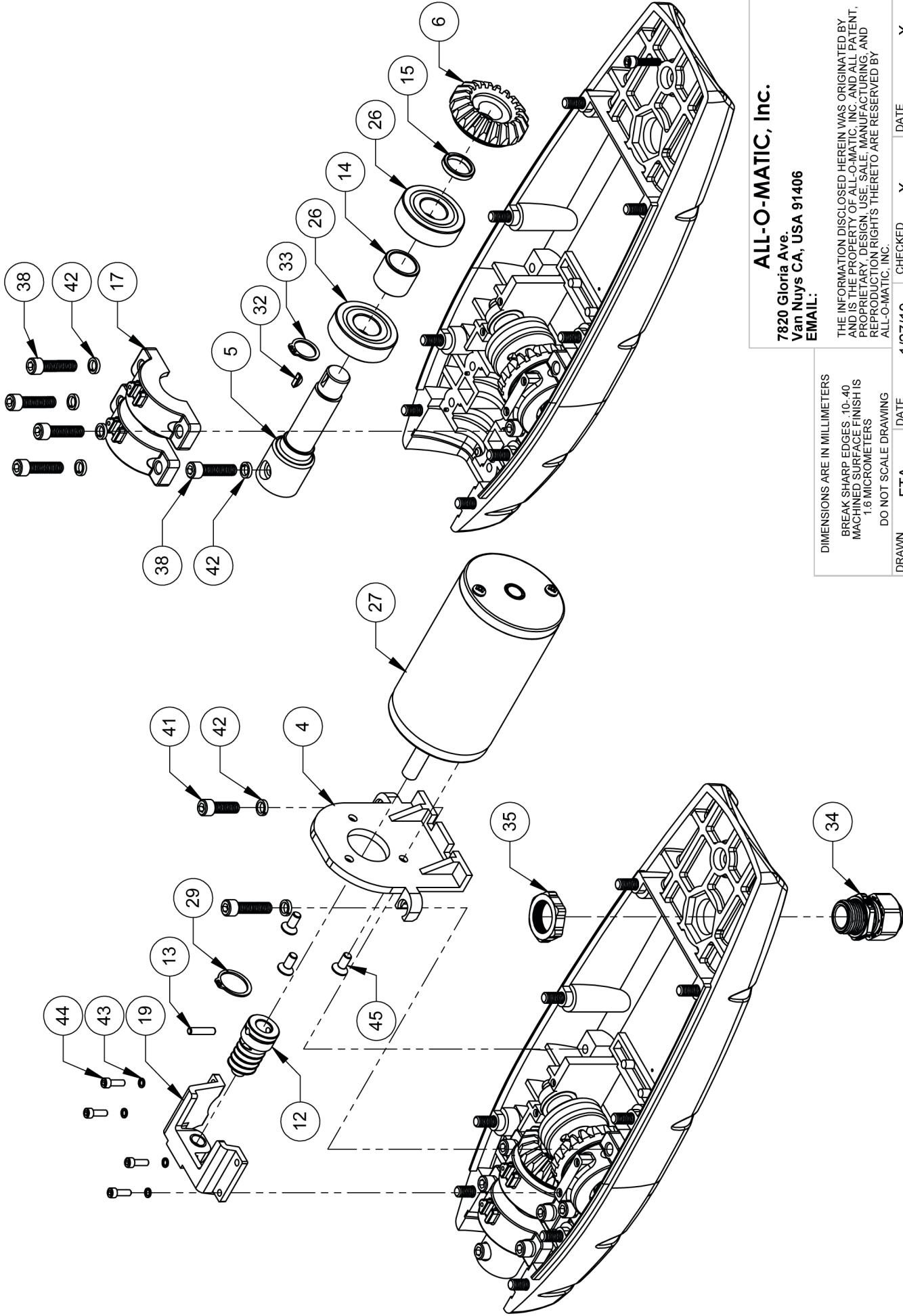

ALL-O-MATIC, Inc.

7820 Gloria Ave.
Van Nuys CA, USA 91406
EMAIL:

THE INFORMATION DISCLOSED HEREIN WAS ORIGINATED BY AND IS THE PROPERTY OF ALL-O-MATIC, INC. AND ALL PATENT, PROPRIETARY, DESIGN, USE, SALE, MANUFACTURING, AND REPRODUCTION RIGHTS THERETO ARE RESERVED BY ALL-O-MATIC, INC.

DIMENSIONS ARE IN MILLIMETERS
BREAK SHARP EDGES .10-.40
MACHINED SURFACE FINISH IS
1.6 MICROMETERS
DO NOT SCALE DRAWING

DRAWN BY:	FTA	DATE DRAWN:	1/27/19	CHECKED BY:	X	DATE CHECKED:	X
MATERIAL:							
RAW MAT:							

1	PROTOTYPE RELEASE	FTA	1/27/19						
SYMBOL	ECO#	ENGINEERING CHANGE ORDER REVISION DESCRIPTION	BY	CKD	DATE	SHEET 2 OF 3	SCALE: 1:3	DRAWING SIZE: A	PART#: T24-025

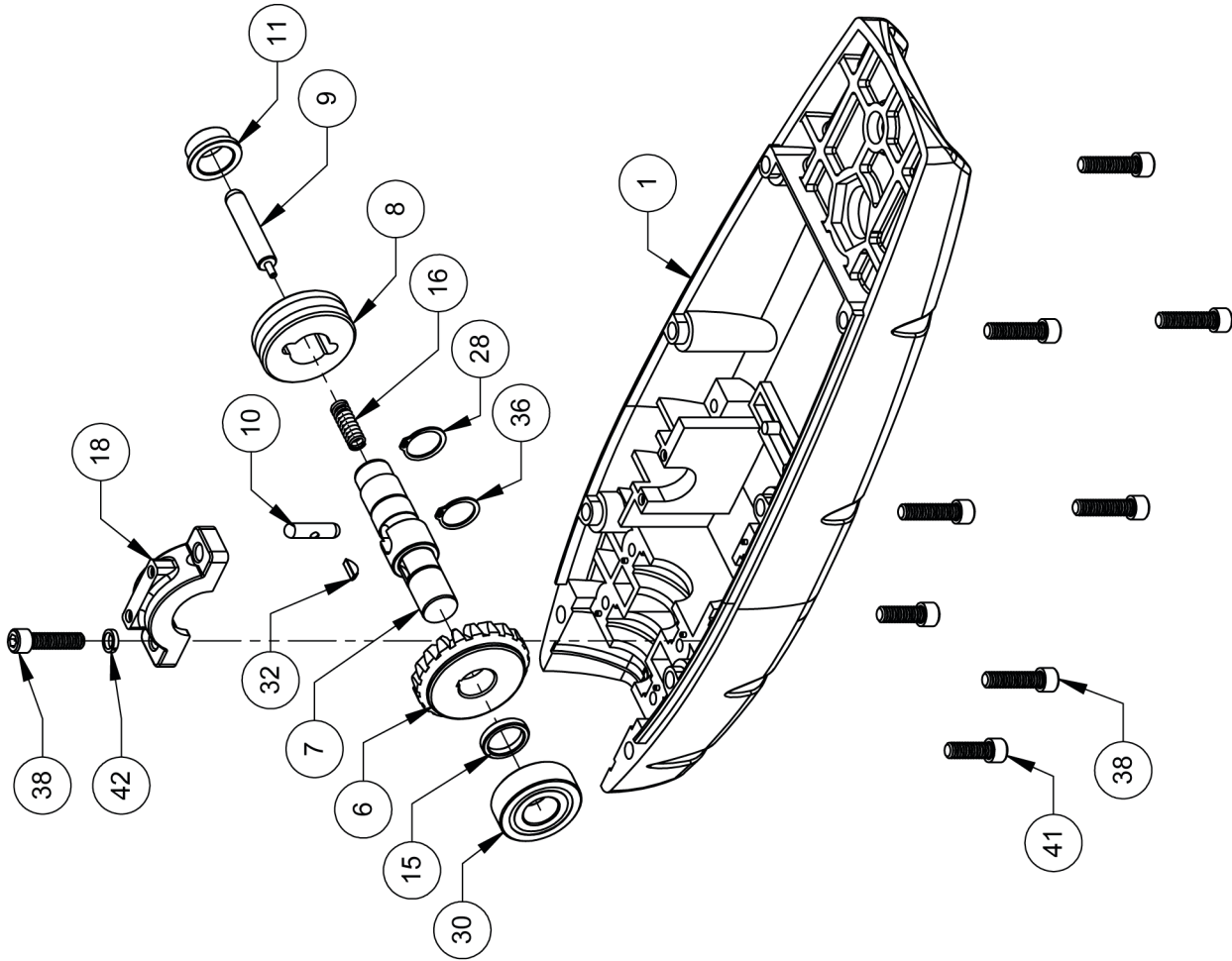

ALL-O-MATIC, Inc.
 7820 Gloria Ave.
 Van Nuys CA, USA 91406
 EMAIL:

THE INFORMATION DISCLOSED HEREIN WAS ORIGINATED BY AND IS THE PROPERTY OF ALL-O-MATIC, INC. AND ALL PATENT, PROPRIETARY, DESIGN, USE, SALE, MANUFACTURING, AND REPRODUCTION RIGHTS THERE TO ARE RESERVED BY ALL-O-MATIC, INC.

DIMENSIONS ARE IN MILLIMETERS
 BREAK SHARP EDGES .10-.40
 MACHINED SURFACE FINISH IS
 1.6 MICROMETERS

DO NOT SCALE DRAWING

DRAWN BY: FTA DATE DRAWN: 1/27/19 CHECKED BY: X DATE CHECKED: X
 MATERIAL: RAW MAT:

1	PROTOTYPE RELEASE	FTA	1/27/19	DATE	1/27/19	DATE	1:3	SCALE:	3	SHEET	3	OF	3	DRAWING SIZE:	A	PART#:	T24-025
SYMBOL	ECCO#	ENGINEERING CHANGE ORDER REVISION DESCRIPTION	BY	CKD	DATE	DATE	SCALE:	SHEET	OF	SHEET	OF	SHEET	DRAWING SIZE:	PART#:	T24-025		

OPERATOR PARTS DIAGRAM

ITEM NO.	QTY.	PART NUMBER
1	1	T24-027, REV 2, DRIVE HOUSING
2	1	T24-028, REV 1, SHAFT TUBE, STAINLESS STEEL
3	1	T24-029, REV 2, DRIVE SCREW SHAFT
4	1	T24-030, REV 2, END CAP, DRIVE HOUSING
5	1	T24-031, REV 2, PLASTIC BEARING FLANGE
6	1	T24-032, REV 2, PLASTIC NUT, DRIVE SHAFT
7	2	T24-033, REV 1, LIMIT SWITCH ASSY
8	1	T24-038, REV 2, ATTACHMENT HEAD
9	1	T24-039, REV 2, COVER, DRIVE HOUSING
10	1	T24-040, REV 1, SEAL, COVER
11	1	T24-041, REV 3, LIMIT RAIL
12	1	T24-043, REV 1, BUSHING, DELRIN
13	1	91585A954, DOWEL PIN, 12 mm DIA x 30 mm LG
14	3	CR-PHMS 0.112-40x0.25x0.25-N
15	4	CR-PHMS 0.138-32x0.5x0.5-N
16	1	HX-SHCS 0.19-24x0.375x0.375-N
17	1	HX-SHCS 0.19-24x0.875x0.875-N
18	1	M5XNNUT 0.190-24-S-N
19	1	PAN HEAD SELF TAPPING SCREW, #4 x 3/4" LG

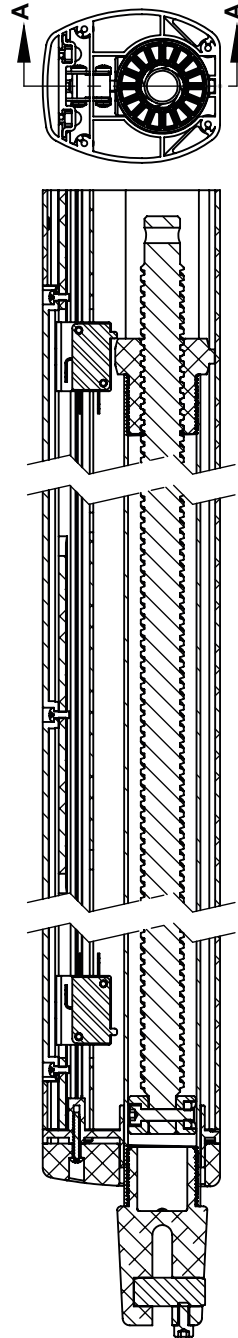
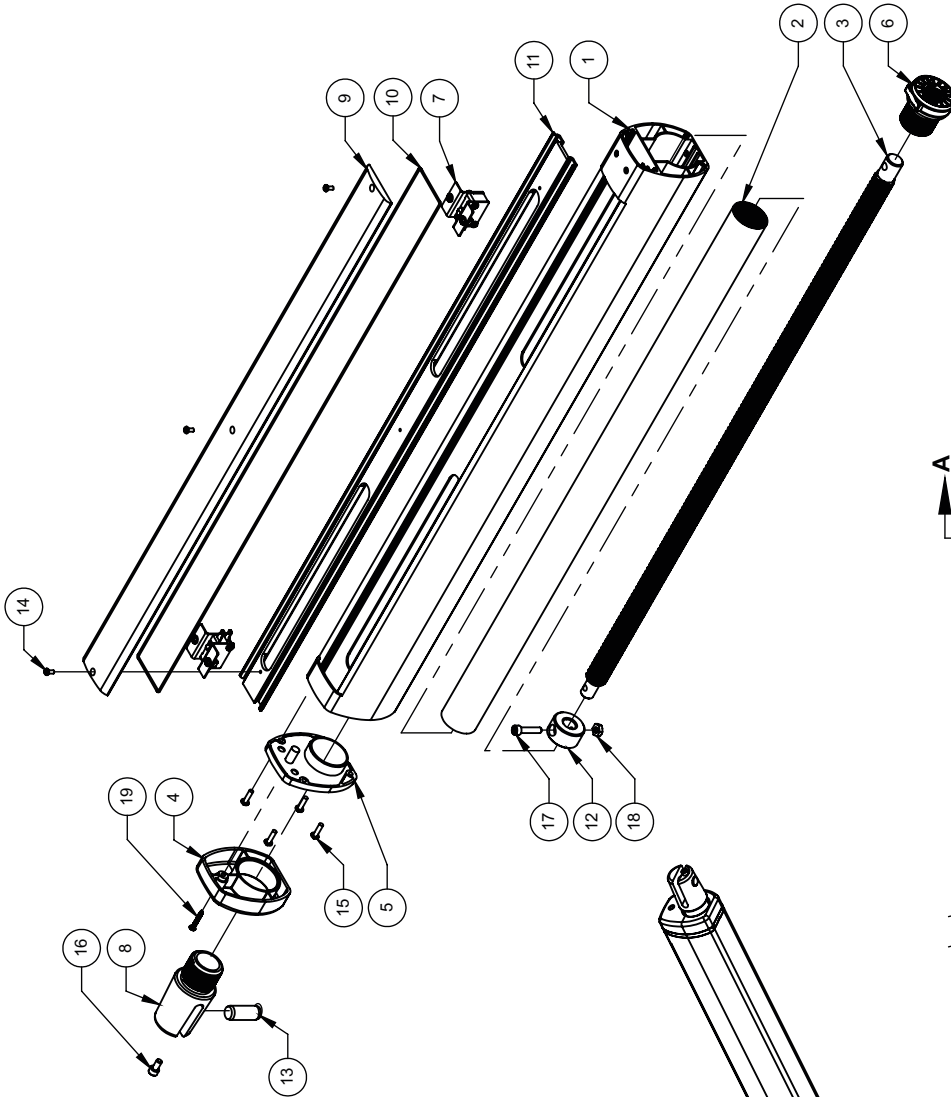

ALL-O-MATIC, Inc.

DIMENSIONS ARE IN MILLIMETERS
BREAK SHARP EDGES 10-40
MACHINED SURFACE FINISH IS
1.8 MICROMETERS
DO NOT SCALE DRAWING

THE INFORMATION DISCLOSED HEREIN WAS ORIGINATED BY
AND IS THE PROPERTY OF ALL-O-MATIC, INC. AND ALL PATENT,
RIGHTS AND REPRODUCTION RIGHTS THERE TO ARE RESERVED BY
ALL-O-MATIC, INC.

DRAWN BY	FTA	DATE	2/1/19	CHECKED BY		DATE	
MATERIAL							
REVISION							

TITLE:	DRIVE HOUSING ASSY
SHEET	1 OF 1
SCALE	1:4
DRAWING SIZE	B
PART#	T24-026

BY		DATE	2/8/19
ENGINEERING CHANGE ORDER DESCRIPTION			

SECTION A-A	2	PROTOTYPE RELEASE
SCALE 1:2		